

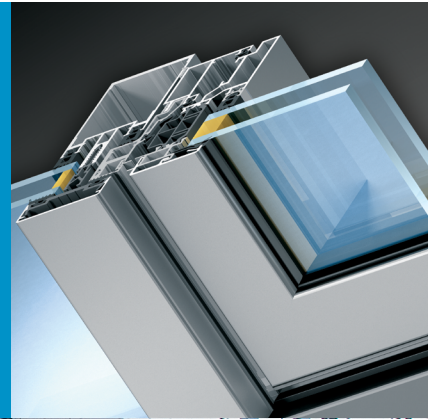

# Profile systems

## **ALUTECH ALT F50**

Curtain wall system









**ALUTECH ALT F50**  
CURTAIN WALL  
SYSTEM

# CONTENT

01	Description
02	Order information. Coding
03	Accessories
04	Gaskets (1:1)
05	PVC profiles (PVC-U-HI), PE (1:1).
06	System profiles (1:1)
07	Reinforced profiles (1:1)
08	Ventilation and moisture removal
09	Glazing table
10	Sections and joint solutions
11	Assemblage and installation
12	Example of standard construction calculation
13	Profiles treatment

01

02

03

04

05

06

07

08

09

10

11

12

13





**ALUFACH ALTF50**  
CURTAIN WALL  
SYSTEM

## DESCRIPTION

01





## Description

ALT F50 system is a light translucent building envelope designed to be either suspended or fixed to the floor slab. It is also suitable for manufacturing skylights, conservatories, green houses and other constructions. Vertical (mullions) and horizontal (transoms) elements with a visible width of 50 mm serve as a supporting structure, which increases lightness and transparency of the facade. The ALT F50 curtain wall series provides several ways of creating mullion and transom junctions:

- 6 mm notch connection (without mullion grooving);
- 6 mm notch connection with shaping (with mullion grooving).

Design engineers have the possibility to select necessary load-bearing elements depending on the loads and the building's structure. That's why the ALT F50 series includes a wide range of additional mullions and transoms. Besides, the case of exceptionally high loads all the mullions and transoms can be strengthened. A wide range of transom profiles permits the installation of transoms of the same size as mullions if it's necessary. It's particularly convenient during assemblage of the building envelope to the floor slab joining point or during mounting of automatic sliding doors into facade construction.

A mullion can be used as a transom in this system. It allows our clients to reduce waste left from mullion profiles. It will also ensure nil waste production and will optimise the process of profile cutting.

During temperature swings, horizontal changes occur in the size of construction elements. This is made up through combining transom special treatment and decorative end caps. They hide the joining point of mullion and transom butts. Vertical changes in the size of construction elements are made up by a mutual (telescopic) junction of two mullions using insert profile and ornamental plastic elements hiding joint point.

In the ALT F50 series a number of tools are used in order to obtain necessary thermal and soundproof properties of the walling. First of all, a set of heat-plugs (heat insulators) is used which are made of hard and shockproof polyvinyl chloride (PVC-U-HI) with high heat insulating properties. Secondly, a set of sealing gaskets are used made from ethylene-propylene rubber (EPDM) and finally, seam sealing made from expanded material. We can achieve the following parameters of thermal isolation in nodal solution (according to standard DIN 4108-4) through the optimal combination of these components:

- In the case of installing infill units 26 mm thick and using PVC-U-HI heat-plug, thermal transmission coefficient  $U_f = 2,4 \text{ W} / (\text{m}^2 \text{ K})$  or reduced total thermal resistance  $R_{pr} = 0,42 \text{ m}^2 \text{ }^\circ\text{C} / \text{W}$  (frame material group 2.1);
- In the case of installing infill units 56 mm thick and using seam sealing AYPC.F50.0913 made from expanded material a thermal transmission coefficient  $U_f = 0,65 \text{ W} / (\text{m}^2 \text{ K})$  is achieved or reduced total thermal resistance  $R_{pr} = 1,53 \text{ m}^2 \text{ }^\circ\text{C} / \text{watt}$ .

Heat-plugs and gaskets allow installing the infill units (glass, sealing, insulated panels, etc.) with infill thickness of 4 to 56 mm. Glazing and installation of panels or window units are made from outside the building. Infill is fixed with clamp bars, which are fixed to the bearing profile with the help of stainless steel screws (A2 or A4) spaced not more than 250 mm apart. From the outside clamp bars are covered with cover caps of different configurations. The covers can be coated with any RAL colour or anodised. This facade can also be of two colours—internal facade elements (mullions and transoms) can be coated with one colour, and outside elements (decorative cover caps) with another one.

In the positions where infill units are installed, all mullion and transom profiles have grooves that serve for condensate disposal and seam area ventilation.

All clamping elements should be made of stainless steel (A2 or A4). It prevents corrosion and ensures a long operational life for the facade without losing of its strength parameters.

Facade construction can be supplied with windows and doors of any type of opening.

Static and strength projections of each particular facade construction is calculated during engineering. This catalogue contains all the inertia data of profiles required for static calculations.

## Materials used

### Aluminium profiles

Profiles are made of alloy EN AW 6063 in accordance with EN 12020-1, condition T6. The alloy is resistant to corrosion and permits the production of high strength profiles.

Aluminium profile systems have polymeric powder coating (Qualicoat requirements) or anodic oxide (correspondent to Qualanod requirements). The thickness of polymeric coating is not less than 60 microns, the anodised layer is up to 20 microns.

### Gaskets

Rubber gaskets produced from ethylene-propylene rubber (EPDM) are used to seal infill units and to prevent the contact of aluminium with other materials (glass, steel). Sealing gaskets are joined in the corners with the help of cyanoacrylate based glue.

### Profiles with thermal break

Thermally broken profiles are extruded from solid shock resistant polyvinylchloride (PVC-U-HI) with good mechanical and thermophysical properties.

### Connectors and fasteners

All the connectors and fasteners used in the construction (self-tapping screws, bolts, nuts etc.) should be made of stainless steel (A2 or A4).

### Insulating materials

All the insulating materials used in the facade construction should meet the requirements of regulatory documents.

### Sheet aluminium

Aluminium sheets are used as shaped elements (panel strips, drip strips, etc.) or multilayer filling elements and should have paint and lacquer coating with a thickness of not less than 1.5 mm.

### Sheet steel elements

Sheet steel used in the invisible part of the facade must be protected from corrosion with zinc or other coating, resistant to corrosion.

The system developer reserves the right to make changes related to the improvement and further development of the series.

All the materials of this publication belong to the developer of the system, their unauthorized duplication is prohibited.



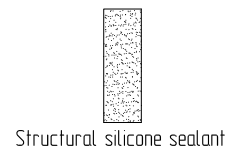
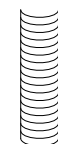
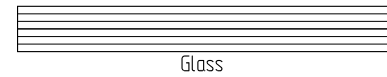
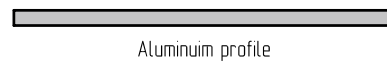
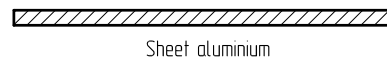
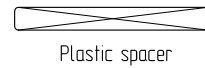
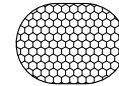
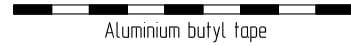
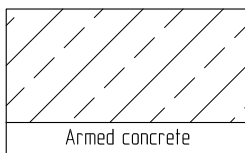
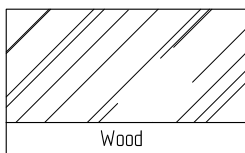
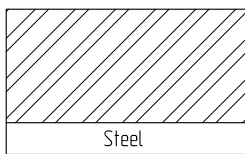
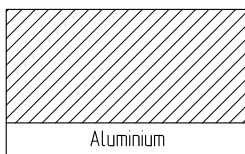
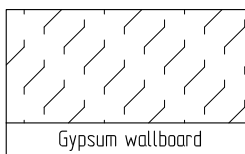
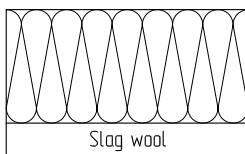
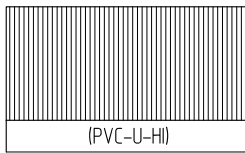
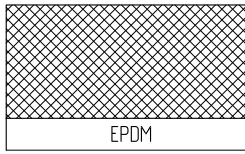





**ALUFACH ALTF50**  
CURTAIN WALL  
SYSTEM

ORDER  
INFORMATION.  
CODING

02



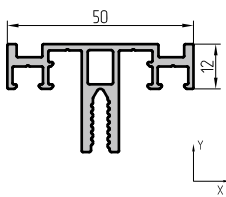
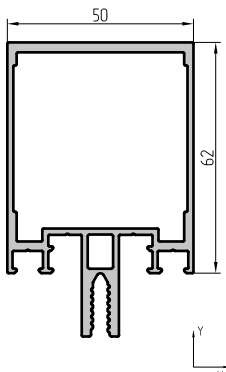
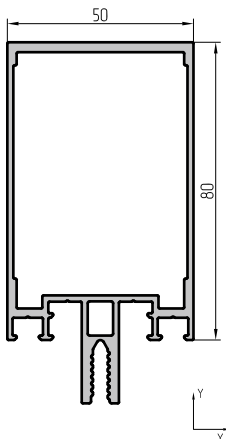
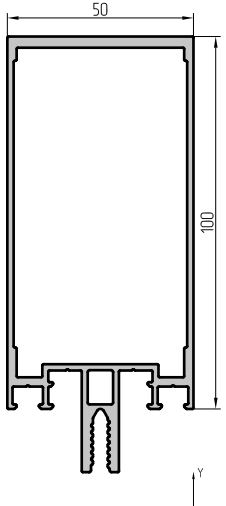

Article Drawing	Weight, kg/m	J <sub>x</sub> , cm <sup>4</sup>	W <sub>x</sub> , cm <sup>3</sup>	J <sub>y</sub> , cm <sup>4</sup>	W <sub>y</sub> , cm <sup>3</sup>	External perimeter, mm	Cross sectional area, cm <sup>2</sup>	Codes	Profile colour	Bar length, m	Quantity in package		Weight of package	
											pcs	m	net, kg	gross, kg
AYPC.F50.0101 	0,853	2,09	1,08	5,50	2,20	285,6	3,148	11200100	00	6,8	4	27,2	23,2	23,6
11200121								RAL9016	24,5				25,0	
11200124								RAL8014	24,5				25,0	
11200130								RAL8017	24,5				25,0	
11200131								RAL9006	24,5				25,0	
112001808								A00-D6	23,2				23,6	
AYPC.F50.0102 	1,668	40,79	9,95	17,94	7,18	372,6	6,156	11200200	00	6,8	2	13,6	22,7	23,4
11200221								RAL9016	23,6				24,3	
11200224								RAL8014	23,6				24,3	
11200230								RAL8017	23,6				24,3	
11200231								RAL9006	23,6				24,3	
112002808								A00-D6	22,7				23,4	
AYPC.F50.0103 	1,824	71,55	14,73	21,32	8,53	408,6	6,732	11200300	00	6,8	2	13,6	24,8	25,6
11200321								RAL9016	25,8				26,6	
11200324								RAL8014	25,8				26,6	
11200330								RAL8017	25,8				26,6	
11200331								RAL9006	25,8				26,6	
112003808								A00-D6	24,8				25,6	
AYPC.F50.0104 	2,078	123,79	21,13	26,16	10,46	450,5	7,667	11200400	00	6,8	2	13,6	28,3	29,1
11200421								RAL9016	29,4				30,2	
11200424								RAL8014	29,4				30,2	
11200430								RAL8017	29,4				30,2	
11200431								RAL9006	29,4				30,2	
112004808								A00-D6	28,3				29,1	

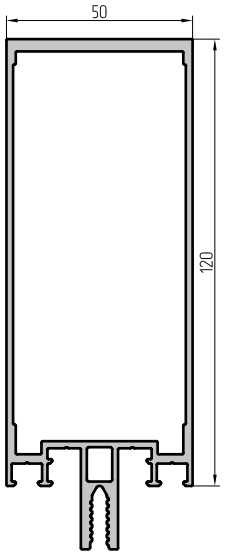
Article Drawing	Weight, kg/m	J <sub>x</sub> , cm <sup>4</sup>	W <sub>x</sub> , cm <sup>3</sup>	J <sub>y</sub> , cm <sup>4</sup>	W <sub>y</sub> , cm <sup>3</sup>	External perimeter, mm	Cross sectional area, cm <sup>2</sup>	Codes	Profile colour	Bar length, m	Quantity in package		Weight of package	
											pcs	m	net, kg	gross, kg
AYPC.F50.0105 	2,362	196,33	28,52	31,46	12,58	487,8	8,716	11200500 11200521 11200524 11200530 11200531 112005808	00 RAL9016 RAL8014 RAL8017 RAL9006 A00-D6	6,8	2	13,6	32,1 33,3 33,3 33,3 33,3 32,1	33,1 34,3 34,3 34,3 34,3 33,1
AYPC.F50.0106 	2,620	283,75	36,14	36,90	14,76	527,8	9,669	11200600 11200621 11200624 11200630 11200631 112006808	00 RAL9016 RAL8014 RAL8017 RAL9006 A00-D6	6,8	2	13,6	35,6 37,0 37,0 37,0 37,0 35,6	36,6 37,9 37,9 37,9 37,9 36,6

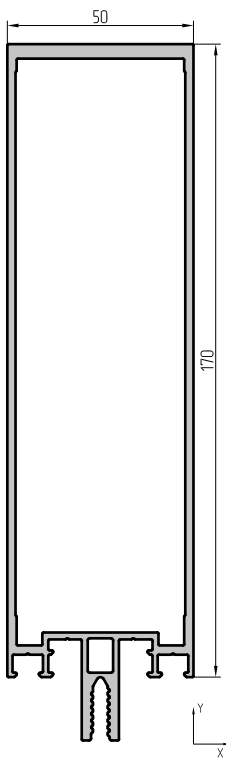
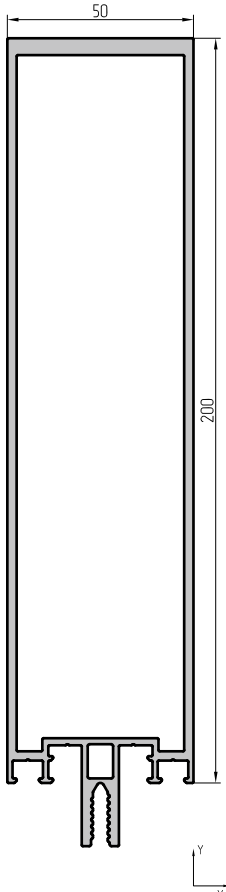

Article	Drawing	Weight, kg/m	J <sub>x</sub> , cm <sup>4</sup>	W <sub>x</sub> , cm <sup>3</sup>	J <sub>y</sub> , cm <sup>4</sup>	W <sub>y</sub> , cm <sup>3</sup>	External perimeter, mm	Cross sectional area, cm <sup>2</sup>	Codes	Profile colour	Bar length, m	Quantity in package		Weight of package		
												pcs	m	net, kg	gross, kg	
AYPC.F50.0107		3,230	487,60	53,47	48,60	19,44	587,8	11,963	11207800	00	6,8	2	13,6	43,9	45,2	
	11207821								RAL9016	45,5						46,8
	11207824								RAL8014	45,5						46,8
	11207830								RAL8017	45,5						46,8
	11207831								RAL9006	45,5						46,8
	112078808								A00-D6	43,9						45,2
AYPC.F50.0108		3,945	777,44	68,73	62,03	24,81	647,8	14,601	11207900	00	6,8	1	6,8	26,8	27,7	
	11207921								RAL9016	27,7						28,5
	11207924								RAL8014	27,7						28,5
	11207930								RAL8017	27,7						28,5
	11207931								RAL9006	27,7						28,5
	112079808								A00-D6	26,8						27,7

Article	Drawing	Weight, kg/m	J <sub>x</sub> , cm <sup>4</sup>	W <sub>x</sub> , cm <sup>3</sup>	J <sub>y</sub> , cm <sup>4</sup>	W <sub>y</sub> , cm <sup>3</sup>	External perimeter, mm	Cross sectional area, cm <sup>2</sup>	Codes	Profile colour	Bar length, m	Quantity in package		Weight of package	
												pcs	m	net, kg	gross, kg
AYPC.F50.0109		2,597	85,41	15,72	85,41	15,72	617,4	9,583	11200700 11200721 11200724 11200730 11200731 112007808	00 RAL9016 RAL8014 RAL8017 RAL9006 A00-D6	6,8	2	13,6	35,3 36,8 36,8 36,8 36,8 35,3	36,1 37,6 37,6 37,6 37,6 36,1
AYPC.F50.0110		5,018	1261,03	97,68	73,59	29,43	707,6	18,586	11251000 11251021 11251024 11251030 11251031 112510808	00 RAL9016 RAL8014 RAL8017 RAL9006 A00-D6	6,8	1	6,8	34,1 34,7 34,7 34,7 34,7 34,1	35,2 35,8 35,8 35,8 35,8 35,2

Article	Drawing	Weight, kg/m	J <sub>x</sub> , cm <sup>4</sup>	W <sub>x</sub> , cm <sup>3</sup>	J <sub>y</sub> , cm <sup>4</sup>	W <sub>y</sub> , cm <sup>3</sup>	External perimeter, mm	Cross sectional area, cm <sup>2</sup>	Codes	Profile colour	Bar length, m	Quantity in package		Weight of package	
												pcs	m	net, kg	gross, kg
AYPC.F50.0111		5,558	1865,96	125,32	84,88	33,95	787,6	20,586	11251100 11251121 11251124 11251130 11251131 112511808	00 RAL9016 RAL8014 RAL8017 RAL9006 A00-D6	6,8	1	6,8	37,8 38,4 38,4 38,4 38,4 37,8	39,0 39,6 39,6 39,6 39,6 39,0
AYPC.F50.0113		1,566	55,16	11,18	5,58	3,34	428,5	5,777	11205000 11205021 11205024 11205030 11205031 112050808	00 RAL9016 RAL8014 RAL8017 RAL9006 A00-D6	6,8	4	27,2	42,6 44,9 44,9 44,9 44,9 42,6	43,4 45,8 45,8 45,8 45,8 43,4

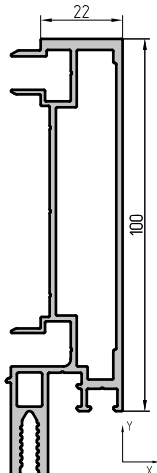
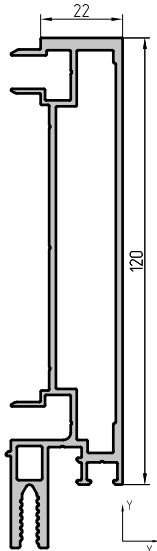
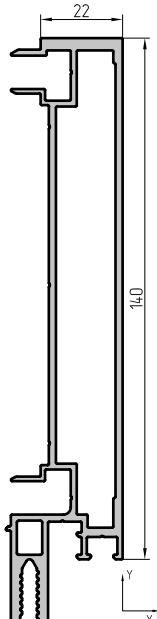
Article Drawing	Weight, kg/m	J <sub>x</sub> , cm <sup>4</sup>	W <sub>x</sub> , cm <sup>3</sup>	J <sub>y</sub> , cm <sup>4</sup>	W <sub>y</sub> , cm <sup>3</sup>	External perimeter, mm	Cross sectional area, cm <sup>2</sup>	Codes	Profile colour	Bar length, m	Quantity in package		Weight of package	
											pcs	m	net, kg	gross, kg
AYPC.F50.0114 	1,789	95,37	15,96	6,39	3,69	467,7	6,602	11205100 11205121 11205124 11205130 11205131 112051808	00 RAL9016 RAL8014 RAL8017 RAL9006 A00-D6	6,8	4	27,2	48,7 51,2 51,2 51,2 51,2 48,7	49,6 52,1 52,1 52,1 52,1 49,6
AYPC.F50.0115 	2,039	151,34	21,65	7,23	4,06	506,5	7,525	11205200 11205221 11205224 11205230 11205231 112052808	00 RAL9016 RAL8014 RAL8017 RAL9006 A00-D6	6,8	2	13,6	27,7 29,1 29,1 29,1 29,1 27,7	28,5 29,8 29,8 29,8 29,8 28,5
AYPC.F50.0116 	2,292	222,26	27,73	8,08	4,44	546,3	8,458	11205300 11205321 11205324 11205330 11205331 112053808	00 RAL9016 RAL8014 RAL8017 RAL9006 A00-D6	6,8	2	13,6	31,2 32,7 32,7 32,7 32,7 31,2	32,0 33,4 33,4 33,4 33,4 32,0

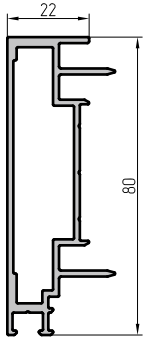
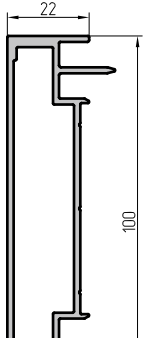
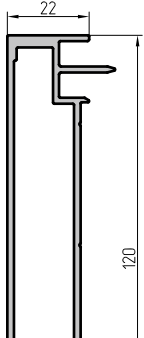
Article Drawing	Weight, kg/m	J <sub>x</sub> , cm <sup>4</sup>	W <sub>x</sub> , cm <sup>3</sup>	J <sub>y</sub> , cm <sup>4</sup>	W <sub>y</sub> , cm <sup>3</sup>	External perimeter, mm	Cross sectional area, cm <sup>2</sup>	Codes	Profile colour	Bar length, m	Quantity in package		Weight of package	
											pcs	m	net, kg	gross, kg
AYPC.F50.0123 	1,094	27,87	6,50	2,61	1,38	299,1	4,037	11205400 11205421 11205424 11205430 11205431 112054808	00 RAL9016 RAL8014 RAL8017 RAL9006 A00-D6	6,8	4	27,2	29,8 31,4 31,4 31,4 31,4 29,8	30,5 32,1 32,1 32,1 32,1 30,5
AYPC.F50.0124 	1,314	52,51	10,00	3,24	1,70	339,6	4,849	11205500 11205521 11205524 11205530 11205531 112055808	00 RAL9016 RAL8014 RAL8017 RAL9006 A00-D6	6,8	4	27,2	35,7 37,6 37,6 37,6 37,6 35,7	36,6 38,4 38,4 38,4 38,4 36,6
AYPC.F50.0125 	1,555	88,47	14,08	3,93	2,06	379,5	5,740	11205600 11205621 11205624 11205630 11205631 112056808	00 RAL9016 RAL8014 RAL8017 RAL9006 A00-D6	6,8	2	13,6	21,1 22,2 22,2 22,2 22,2 21,1	21,8 22,8 22,8 22,8 22,8 21,8

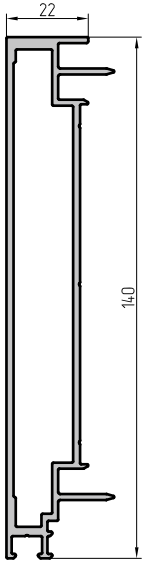
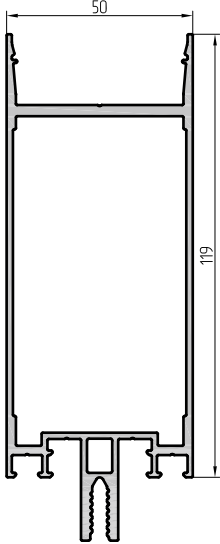
Article	Drawing	Weight, kg/m	J <sub>x</sub> , cm <sup>4</sup>	W <sub>x</sub> , cm <sup>3</sup>	J <sub>y</sub> , cm <sup>4</sup>	W <sub>y</sub> , cm <sup>3</sup>	External perimeter, mm	Cross sectional area, cm <sup>2</sup>	Codes	Profile colour	Bar length, m	Quantity in package		Weight of package	
												pcs	m	net, kg	gross, kg
AYPC.F50.0126		1,807	136,73	18,77	4,68	2,45	418,4	6,668	11205700 11205721 11205724 11205730 11205731 112057808	00 RAL9016 RAL8014 RAL8017 RAL9006 A00-D6	6,8	2	13,6	24,6 25,7 25,7 25,7 25,7 24,6	25,3 26,4 26,4 26,4 26,4 25,3
AYPC.F50.0145		2,280	155,3	21,77	30,6	12,24	526,7	8,433	11254400 11254421 11254424 11254430 11254431 112544808	00 RAL9016 RAL8014 RAL8017 RAL9006 A00-D6	6,8	2	13,6	31,0 31,9 31,9 31,9 31,9 31,0	31,9 32,8 32,8 32,8 32,8 31,9

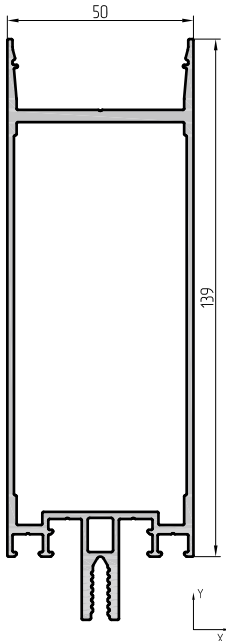
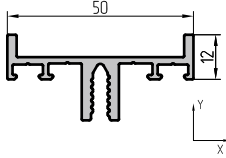
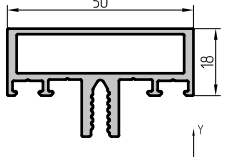
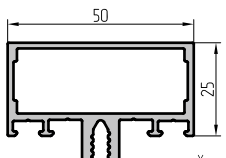
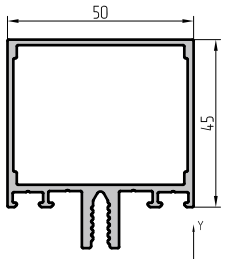
Article Drawing	Weight, kg/m	J <sub>x</sub> , cm <sup>4</sup>	W <sub>x</sub> , cm <sup>3</sup>	J <sub>y</sub> , cm <sup>4</sup>	W <sub>y</sub> , cm <sup>3</sup>	External perimeter, mm	Cross sectional area, cm <sup>2</sup>	Codes	Profile colour	Bar length, m	Quantity in package		Weight of package	
											pcs	m	net, kg	gross, kg
AYPC.F50.0146 	2,560	238,1	29,41	35,9	14,36	565,9	9,482	11254500 11254521 11254524 11254530 11254531 112545808	00 RAL9016 RAL8014 RAL8017 RAL9006 A00-D6	6,8	2	13,6	34,8 35,7 35,7 35,7 35,7 34,8	35,8 36,7 36,7 36,7 36,7 35,8
AYPC.F50.0201 	0,654	0,65	0,49	4,95	1,98	231,9	2,413	11200800 11200821 11200824 11200830 11200831 112008808	00 RAL9016 RAL8014 RAL8017 RAL9006 A00-D6	6,8	6	40,8	26,7 28,3 28,3 28,3 28,3 26,7	27,1 28,7 28,7 28,7 28,7 27,1
AYPC.F50.0202 	0,918	2,11	1,22	7,79	3,12	232,4	3,389	11200900 11200921 11200924 11200930 11200931 112009808	00 RAL9016 RAL8014 RAL8017 RAL9006 A00-D6	6,8	4	27,2	25,0 26,0 26,0 26,0 26,0 25,0	25,5 26,6 26,6 26,6 26,6 25,5
AYPC.F50.0203 	0,962	3,95	2,01	8,77	3,51	246,4	3,550	11201000 11201021 11201024 11201030 11201031 112010808	00 RAL9016 RAL8014 RAL8017 RAL9006 A00-D6	6,8	4	27,2	26,2 27,3 27,3 27,3 27,3 26,2	26,8 28,0 28,0 28,0 28,0 26,8
AYPC.F50.0204 	1,131	13,89	4,85	12,52	5,01	286,4	4,190	11201100 11201121 11201124 11201130 11201131 112011808	00 RAL9016 RAL8014 RAL8017 RAL9006 A00-D6	6,8	4	27,2	30,8 32,3 32,3 32,3 32,3 30,8	31,6 33,2 33,2 33,2 33,2 31,6

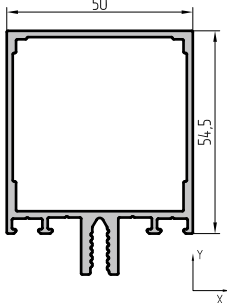
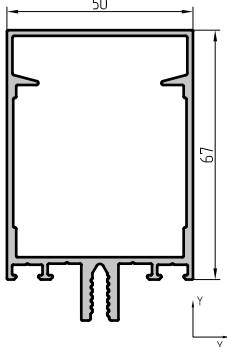
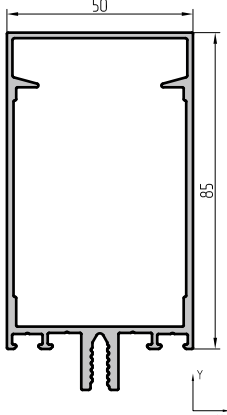
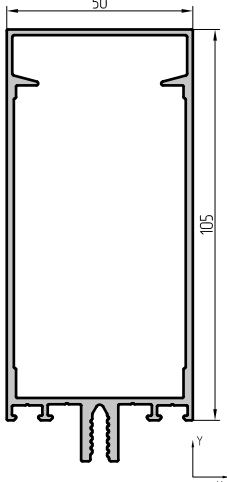
Article Drawing	Weight, kg/m	J <sub>x</sub> , cm <sup>4</sup>	W <sub>x</sub> , cm <sup>3</sup>	J <sub>y</sub> , cm <sup>4</sup>	W <sub>y</sub> , cm <sup>3</sup>	External perimeter, mm	Cross sectional area, cm <sup>2</sup>	Codes	Profile colour	Bar length, m	Quantity in package		Weight of package	
											pcs	m	net, kg	gross, kg
AYPC.F50.0214 	1,274	22,84	6,83	15,13	6,05	305,4	4,717	11250900 11250921 11250924 11250930 11250931 112509808	00 RAL9016 RAL8014 RAL8017 RAL9006 A00-D6	6,8	4	27,2	34,7 35,6 35,6 35,6 35,6 34,7	36,0 37,0 37,0 37,0 37,0 36,0
AYPC.F50.0205 	1,424	35,53	8,75	18,40	7,36	330,4	5,273	11201200 11201221 11201224 11201230 11201231 112012808	00 RAL9016 RAL8014 RAL8017 RAL9006 A00-D6	6,8	2	13,6	21,2 22,1 22,1 22,1 22,1 21,2	21,9 22,8 22,8 22,8 22,8 21,9
AYPC.F50.0206 	1,617	62,67	12,43	22,54	9,02	366,4	5,990	11201300 11201321 11201324 11201330 11201331 112013808	00 RAL9016 RAL8014 RAL8017 RAL9006 A00-D6	6,8	2	13,6	22,0 23,0 23,0 23,0 23,0 22,0	22,8 23,8 23,8 23,8 23,8 22,8
AYPC.F50.0207 	1,857	104,64	17,13	27,50	11,00	406,4	6,854	11205800 11205821 11205824 11205830 11205831 112058808	00 RAL9016 RAL8014 RAL8017 RAL9006 A00-D6	6,8	2	13,6	25,3 26,4 26,4 26,4 26,4 25,3	25,9 27,0 27,0 27,0 27,0 25,9

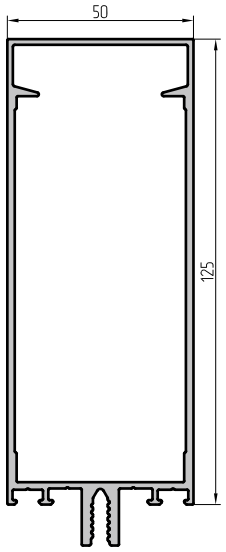

Article	Drawing	Weight, kg/m	J <sub>x</sub> , cm <sup>4</sup>	W <sub>x</sub> , cm <sup>3</sup>	J <sub>y</sub> , cm <sup>4</sup>	W <sub>y</sub> , cm <sup>3</sup>	External perimeter, mm	Cross sectional area, cm <sup>2</sup>	Codes	Profile colour	Bar length, m	Quantity in package		Weight of package	
												pcs	m	net, kg	gross, kg
AYPC.F50.0208		2,113	163,29	22,82	32,86	13,14	446,4	7,796	11205900 11205921 11205924 11205930 11205931 112059808	00 RAL9016 RAL8014 RAL8017 RAL9006 A00-D6	6,8	2	13,6	28,7 30,0 30,0 30,0 30,0 28,7	29,4 30,6 30,6 30,6 30,6 29,4
AYPC.F50.0209		2,390	235,40	28,77	38,65	15,46	486,4	8,820	11206000 11206021 11206024 11206030 11206031 112060808	00 RAL9016 RAL8014 RAL8017 RAL9006 A00-D6	6,8	2	13,6	32,5 33,8 33,8 33,8 33,8 32,5	33,2 34,5 34,5 34,5 34,5 33,2

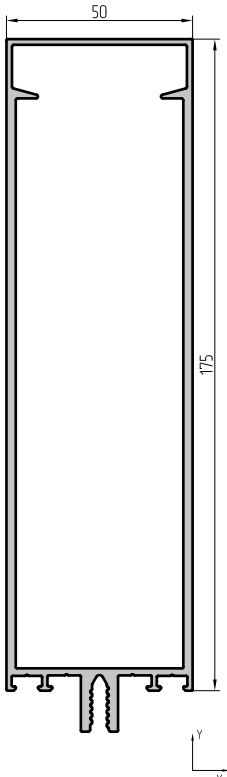
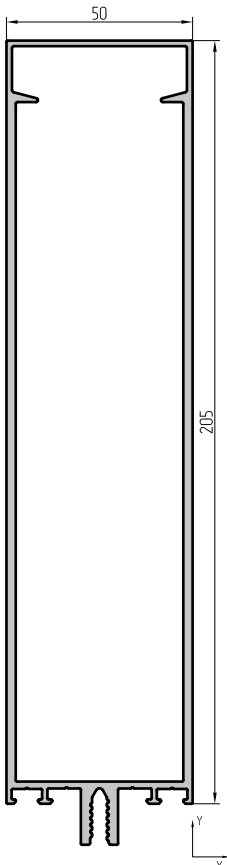
Article Drawing	Weight, kg/m	J <sub>x</sub> , cm <sup>4</sup>	W <sub>x</sub> , cm <sup>3</sup>	J <sub>y</sub> , cm <sup>4</sup>	W <sub>y</sub> , cm <sup>3</sup>	External perimeter, mm	Cross sectional area, cm <sup>2</sup>	Codes	Profile colour	Bar length, m	Quantity in package		Weight of package	
											pcs	m	net, kg	gross, kg
AYPC.F50.0210 	3,035	398,76	41,05	51,72	20,69	545,6	11,242	11208000	00	6,8	2	13,6	41,3	42,5
11208021								RAL9016	42,8				44,0	
11208024								RAL8014	42,8				44,0	
11208030								RAL8017	42,8				44,0	
11208031								RAL9006	42,8				44,0	
112080808								A00-D6	41,3				42,5	
AYPC.F50.0211 	3,437	600,88	54,00	61,13	24,45	605,6	12,730	11208100	00	6,8	1	6,8	23,4	24,2
11208121								RAL9016	24,2				25,0	
11208124								RAL8014	24,2				25,0	
11208130								RAL8017	24,2				25,0	
11208131								RAL9006	24,2				25,0	
112081808								A00-D6	23,4				24,2	

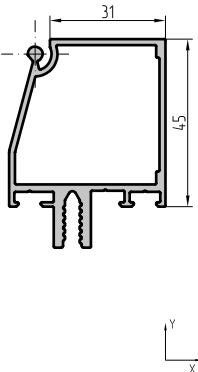
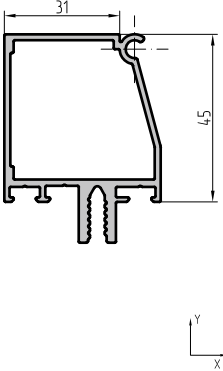
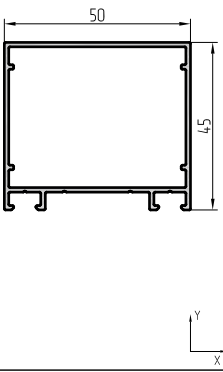
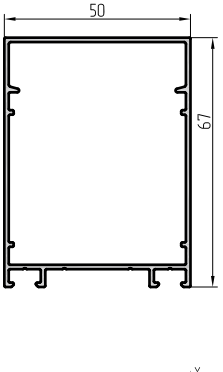
Article Drawing	Weight, kg/m	J <sub>x</sub> , cm <sup>4</sup>	W <sub>x</sub> , cm <sup>3</sup>	J <sub>y</sub> , cm <sup>4</sup>	W <sub>y</sub> , cm <sup>3</sup>	External perimeter, mm	Cross sectional area, cm <sup>2</sup>	Codes	Profile colour	Bar length, m	Quantity in package		Weight of package	
											pcs	m	net, kg	gross, kg
AYPC.F50.0212 	1,061	12,57	4,37	7,53	3,57	271,8	3,928	11206100 11206121 11206124 11206130 11206131 112061808	00 RAL9016 RAL8014 RAL8017 RAL9006 A00-D6	6,8	4	27,2	28,9 30,3 30,3 30,3 30,3 28,9	29,4 30,9 30,9 30,9 30,9 29,4
AYPC.F50.0213 	1,042	12,45	4,28	7,43	3,52	269,0	3,861	11206200 11206221 11206224 11206230 11206231 112062808	00 RAL9016 RAL8014 RAL8017 RAL9006 A00-D6	6,8	4	27,2	28,3 29,8 29,8 29,8 29,8 28,3	28,9 30,4 30,4 30,4 30,4 28,9
AYPC.F50.0215 	0,661	7,06	3,11	9,37	3,75	225,9	2,449	11256300 11256321 11256324 11256330 11256331 112563808	00 RAL9016 RAL8014 RAL8017 RAL9006 A00-D6	6,8	4	27,2	18,0 18,6 18,6 18,6 18,6 18,0	18,8 19,2 19,2 19,2 19,2 18,8
AYPC.F50.0216 	0,822	18,84	5,45	12,88	5,15	269,9	3,047	11256400 11256421 11256424 11256430 11256431 112564808	00 RAL9016 RAL8014 RAL8017 RAL9006 A00-D6	6,8	2	13,6	15,9 16,5 16,5 16,5 16,5 15,9	16,7 17,5 17,5 17,5 17,5 16,7

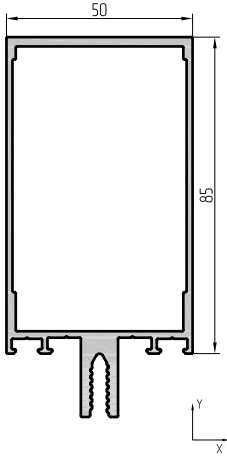
Article Drawing	Weight, kg/m	J <sub>x</sub> , cm <sup>4</sup>	W <sub>x</sub> , cm <sup>3</sup>	J <sub>y</sub> , cm <sup>4</sup>	W <sub>y</sub> , cm <sup>3</sup>	External perimeter, mm	Cross sectional area, cm <sup>2</sup>	Codes	Profile colour	Bar length, m	Quantity in package		Weight of package	
											pcs	m	net, kg	gross, kg
AYPC.F50.0226 	1,777	80,78	15,56	21,59	8,64	383,0	6,580	11253100	00	6,8	2	13,6	24,2	25,0
11253121								RAL9016	24,8				25,6	
11253124								RAL8014	24,8				25,6	
11253130								RAL8017	24,8				25,6	
11253131								RAL9006	24,8				25,6	
112531808								A00-D6	24,2				25,0	
AYPC.F50.0227 	2,039	132,24	21,23	27,13	10,85	422,9	7,555	11253200	00	6,8	2	13,6	27,7	28,6
11253221								RAL9016	28,4				29,3	
11253224								RAL8014	28,4				29,3	
11253230								RAL8017	28,4				29,3	
11253231								RAL9006	28,4				29,3	
112532808								A00-D6	27,7				28,6	
AYPC.F50.0248 	2,090	146,9	20,33	32,5	13,00	470,9	7,724	11254600	00	6,8	2	13,6	28,4	29,3
11254621								RAL9016	29,2				30,1	
11254624								RAL8014	29,2				30,1	
11254630								RAL8017	29,2				30,1	
11254631								RAL9006	29,2				30,1	
112546808								A00-D6	28,4				29,3	

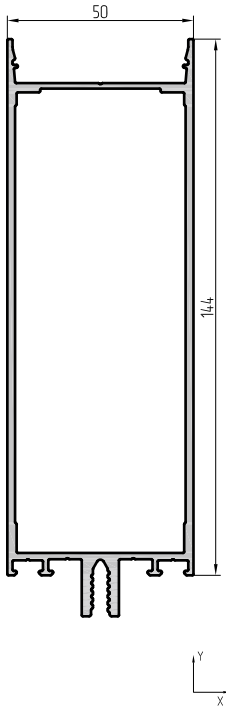
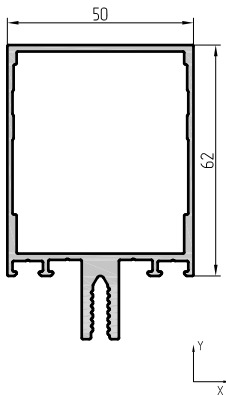
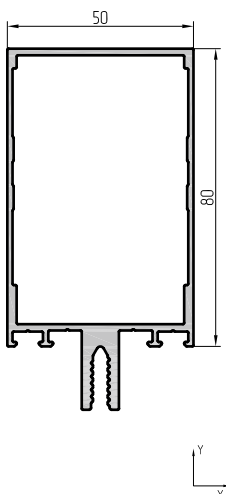
Article Drawing	Weight, kg/m	J <sub>x</sub> , cm <sup>4</sup>	W <sub>x</sub> , cm <sup>3</sup>	J <sub>y</sub> , cm <sup>4</sup>	W <sub>y</sub> , cm <sup>3</sup>	External perimeter, mm	Cross sectional area, cm <sup>2</sup>	Codes	Profile colour	Bar length, m	Quantity in package		Weight of package	
											pcs	m	net, kg	gross, kg
AYPC.F50.0249 	2,360	218,2	26,48	38,3	15,32	510,9	8,748	11254-700	00	6,8	2	13,6	32,1	33,1
11254-721								RAL9016	32,9				34,0	
11254-724								RAL8014	32,9				34,0	
11254-730								RAL8017	32,9				34,0	
11254-731								RAL9006	32,9				34,0	
11254-7808								A00-D6	32,1				33,1	
AYPC.F50.3102 	1,457	35,24	8,52	16,15	6,45	336,9	5,397	11270100	00	6,8	2	13,6	19,8	20,5
11270121								RAL9016	20,4				21,1	
11270124								RAL8014	20,4				21,1	
11270130								RAL8017	20,4				21,4	
112701311								RAL9006	20,4				21,1	
112701808								A00-D6	20,4				20,5	
AYPC.F50.3103 	1,605	62,06	11,93	19,20	7,68	372,9	5,945	11270200	00	6,8	2	13,6	21,8	22,6
11253221								RAL9016	22,4				23,3	
11270224								RAL8014	22,4				23,3	
11270230								RAL8017	22,4				23,3	
11270231								RAL9006	22,4				23,3	
112702808								A00-D6	21,8				22,6	

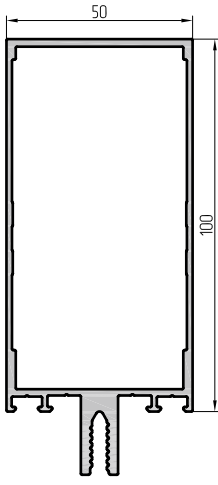
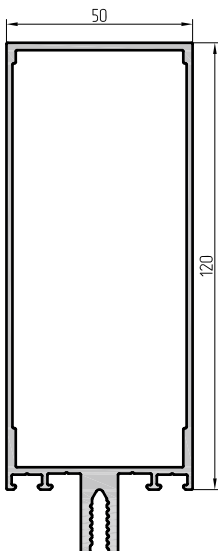
Article Drawing	Weight, kg/m	J <sub>x</sub> , cm <sup>4</sup>	W <sub>x</sub> , cm <sup>3</sup>	J <sub>y</sub> , cm <sup>4</sup>	W <sub>y</sub> , cm <sup>3</sup>	External perimeter, mm	Cross sectional area, cm <sup>2</sup>	Codes	Profile colour	Bar length, m	Quantity in package		Weight of package	
											pcs	m	net, kg	gross, kg
AYPC.F50.3104 	1,816	106,81	17,08	23,39	9,36	412,9	6,728	11270300	00	6,8	2	13,6	24,7	25,6
11270321								RAL9016	25,4				26,3	
11270324								RAL8014	25,4				26,3	
11270330								RAL8017	25,4				26,3	
11270331								RAL9006	25,4				26,3	
112703808								A00-D6	24,7				25,6	
AYPC.F50.3105 	2,018	164,13	22,38	27,72	11,72	452,9	7,473	11270400	00	6,8	2	13,6	27,4	28,4
11270421								RAL9016	28,2				29,1	
11270424								RAL8014	28,2				29,1	
11270430								RAL8017	28,2				29,1	
11270431								RAL9006	28,2				29,1	
112704808								A00-D6	27,4				28,4	

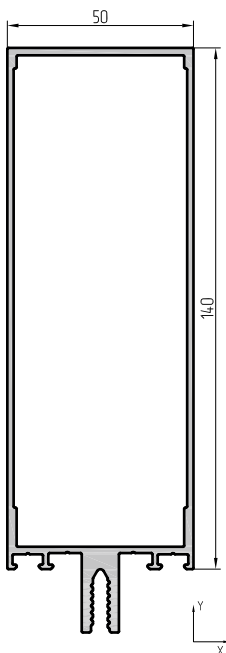
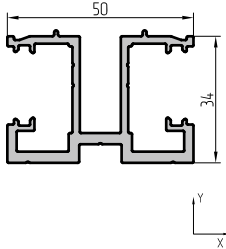
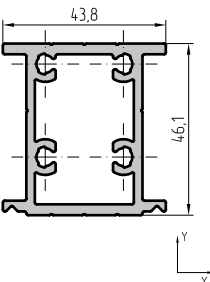
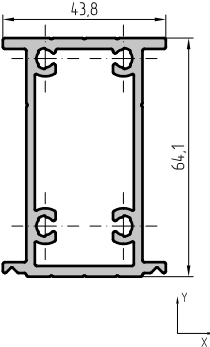
Article Drawing	Weight, kg/m	J <sub>x</sub> , cm <sup>4</sup>	W <sub>x</sub> , cm <sup>3</sup>	J <sub>y</sub> , cm <sup>4</sup>	W <sub>y</sub> , cm <sup>3</sup>	External perimeter, mm	Cross sectional area, cm <sup>2</sup>	Codes	Profile colour	Bar length, m	Quantity in package		Weight of package	
											pcs	m	net, kg	gross, kg
AYPC.F50.3106 	2,254	238,64	28,49	32,76	13,10	492,9	8,349	11270500	00	6,8	2	13,6	30,7	31,7
11270521								RAL9016	31,5				32,6	
11270524								RAL8014	31,5				32,6	
11270530								RAL8017	31,5				32,6	
11270531								RAL9006	31,5				32,6	
112705808								A00-D6	30,7				31,7	
AYPC.F50.0301 	1,148	6,50	6,64	9,14	3,66	377,7	4,235	11201400	00	6,8	4	27,2	31,2	31,8
11201421								RAL9016	32,0				32,6	
11201424								RAL8014	32,0				32,6	
11201430								RAL8017	32,0				32,6	
11201431								RAL9006	32,0				32,6	
112014808								A00-D6	31,2				31,8	
AYPC.F50.0302 	1,426	15,20	6,44	8,82	4,03	205,5	5,282	11201500	00	6,8	4	27,2	38,8	39,3
AYPC.F50.0303 	1,650	34,86	10,87	10,55	4,82	241,5	6,110	11201600	00	6,8	4	27,2	44,9	45,5

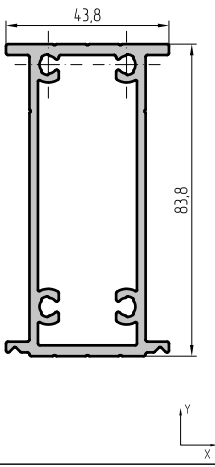
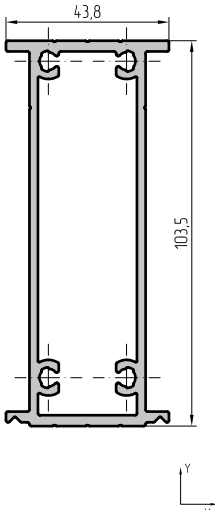
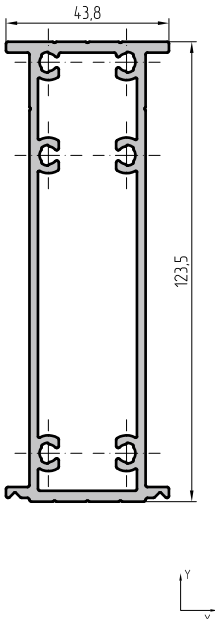
Article Drawing	Weight, kg/m	J <sub>x</sub> , cm <sup>4</sup>	W <sub>x</sub> , cm <sup>3</sup>	J <sub>y</sub> , cm <sup>4</sup>	W <sub>y</sub> , cm <sup>3</sup>	External perimeter, mm	Cross sectional area, cm <sup>2</sup>	Codes	Profile colour	Bar length, m	Quantity in package		Weight of package	
											pcs	m	net, kg	gross, kg
AYPC.F50.0304 	1,894	67,64	16,05	12,45	5,68	280,9	7,016	11201700	00	6,8	2	13,6	25,8	26,3
AYPC.F50.0305 	2,139	114,09	21,86	14,41	6,76	320,3	7,923	11201800	00	6,8	2	13,6	29,1	29,7
AYPC.F50.0306 	2,545	182,50	28,90	16,94	7,74	360,3	9,427	11201900	00	6,8	2	13,6	34,6	35,2

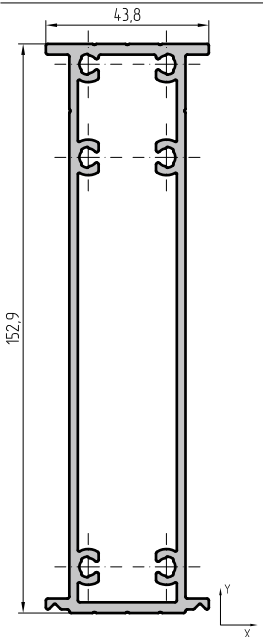
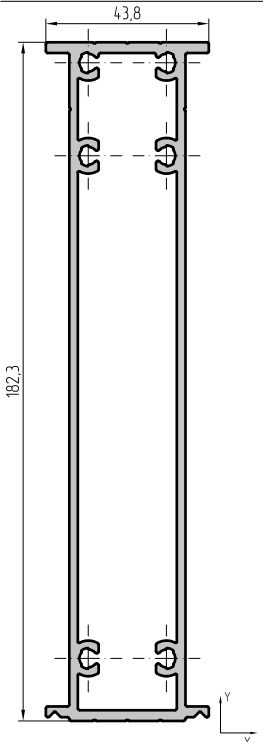
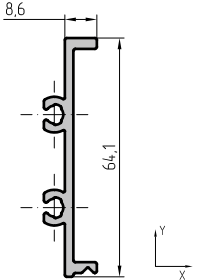

Article	Drawing	Weight, kg/m	J <sub>x</sub> , cm <sup>4</sup>	W <sub>x</sub> , cm <sup>3</sup>	J <sub>y</sub> , cm <sup>4</sup>	W <sub>y</sub> , cm <sup>3</sup>	External perimeter, mm	Cross sectional area, cm <sup>2</sup>	Codes	Profile colour	Bar length, m	Quantity in package		Weight of package	
												pcs	m	net, kg	gross, kg
AYPC.F50.0307		2,910	314,38	40,20	19,77	9,03	419,1	10,780	11208200	00	6,8	2	13,6	39,6	40,2
AYPC.F50.0308		3,276	488,42	52,38	22,60	10,32	477,9	12,132	11208300	00	6,8	2	13,6	44,6	45,4
AYPC.F50.0313		0,649	9,07	2,81	0,18	0,23	202,4	2,396	11206300	00	6,8	10	68,0	44,1	44,7

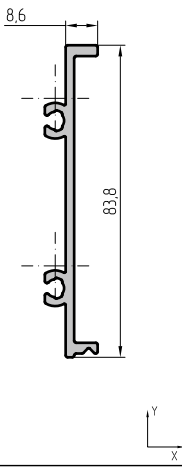
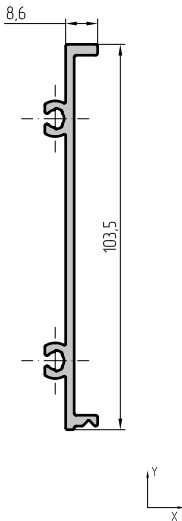
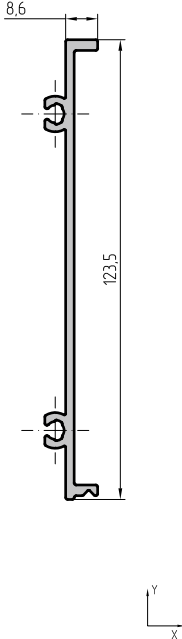

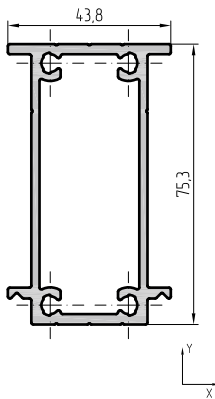
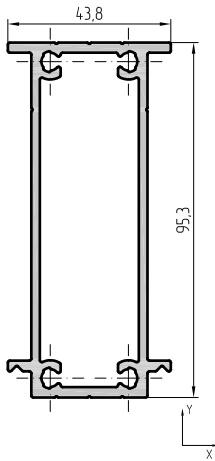
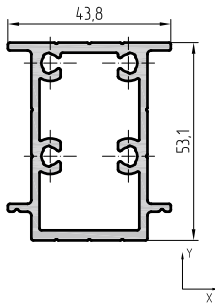
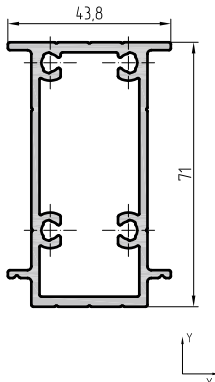
Article Drawing	Weight, kg/m	J <sub>x</sub> , cm <sup>4</sup>	W <sub>x</sub> , cm <sup>3</sup>	J <sub>y</sub> , cm <sup>4</sup>	W <sub>y</sub> , cm <sup>3</sup>	External perimeter, mm	Cross sectional area, cm <sup>2</sup>	Codes	Profile colour	Bar length, m	Quantity in package		Weight of package	
											pcs	m	net, kg	gross, kg
AYPC.F50.0314 	0,772	19,67	4,66	0,18	0,23	241,8	2,849	11206400	00	6,8	8	54,4	42,0	42,5
AYPC.F50.0315 	0,895	35,83	6,88	0,18	0,23	281,2	3,302	11206500	00	6,8	8	54,4	48,7	49,2
AYPC.F50.0316 	1,019	58,76	9,46	0,19	0,25	321,2	3,762	11206600	00	6,8	7	47,6	48,5	49,1

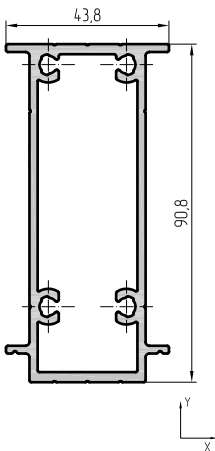
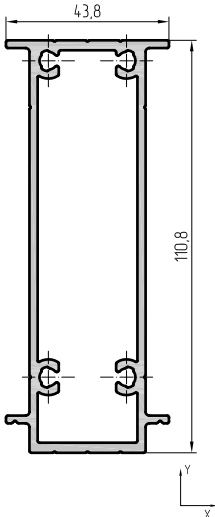
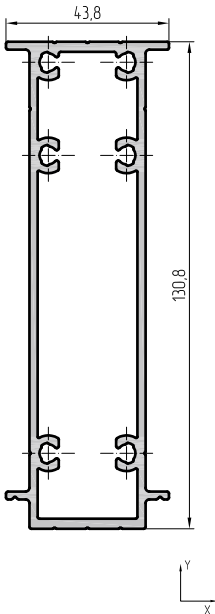
Article Drawing	Weight, kg/m	J <sub>x</sub> , cm <sup>4</sup>	W <sub>x</sub> , cm <sup>3</sup>	J <sub>y</sub> , cm <sup>4</sup>	W <sub>y</sub> , cm <sup>3</sup>	External perimeter, mm	Cross sectional area, cm <sup>2</sup>	Codes	Profile colour	Bar length, m	Quantity in package		Weight of package	
											pcs	m	net, kg	gross, kg
AYPC.F50.0326 	1,661	48,63	12,79	11,00	5,02	419,1	6,150	11253300	00	6,8	2	13,6	22,6	23,1
AYPC.F50.0327 	1,940	87,57	18,24	13,13	6,00	303,9	7,185	11253400	00	6,8	2	13,6	26,4	26,9
AYPC.F50.3302 	1,430	18,74	6,69	8,79	4,01	217,3	5,298	11271100	00	6,8	2	13,6	19,4	19,9
AYPC.F50.3303 	1,643	39,51	10,89	10,45	4,77	253,1	6,086	11271200	00	6,8	2	13,6	22,3	22,8

Article Drawing	Weight, kg/m	J <sub>x</sub> , cm <sup>4</sup>	W <sub>x</sub> , cm <sup>3</sup>	J <sub>y</sub> , cm <sup>4</sup>	W <sub>y</sub> , cm <sup>3</sup>	External perimeter, mm	Cross sectional area, cm <sup>2</sup>	Codes	Profile colour	Bar length, m	Quantity in package		Weight of package	
											pcs	m	net, kg	gross, kg
AYPC.F50.3304 	1,878	73,75	16,10	12,28	5,61	292,7	6,957	11271300	00	6,8	2	13,6	25,5	26,1
AYPC.F50.3305 	2,116	122,09	21,99	14,14	6,46	332,7	7,837	11271400	00	6,8	2	13,6	28,8	29,4
AYPC.F50.3306 	2,516	193,07	28,58	16,69	7,62	372,7	9,317	11271500	00	6,8	2	13,6	34,2	34,9

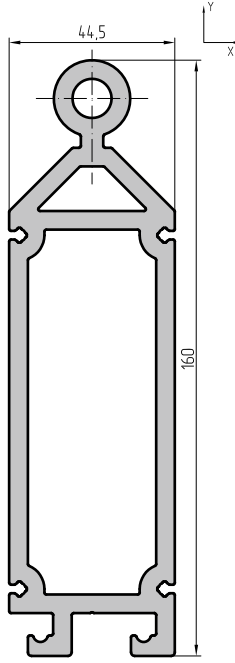
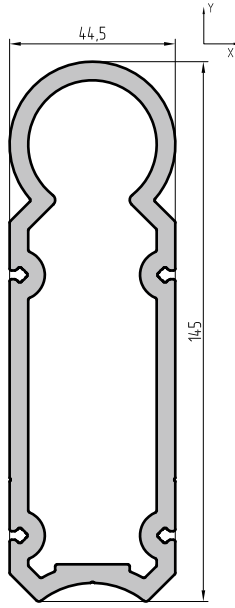
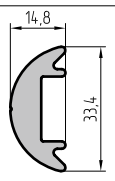
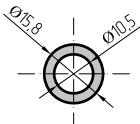
Article	Drawing	Weight, kg/m	J <sub>x</sub> , cm <sup>4</sup>	W <sub>x</sub> , cm <sup>3</sup>	J <sub>y</sub> , cm <sup>4</sup>	W <sub>y</sub> , cm <sup>3</sup>	External perimeter, mm	Cross sectional area, cm <sup>2</sup>	Codes	Profile colour	Bar length, m	Quantity in package		Weight of package	
												pcs	m	net, kg	gross, kg
AYPC.F50.0401		0,347	-	-	-	-	99,6	1,234	11202000	00	6,8	-	-	-	-
AYPC.F50.0402		0,247	-	-	-	-	70,4	0,913	11202100	00	3,4	20	68	16,8	16,85
AYPC.F50.0403		0,919	-	-	-	-	260,8	3,404	11202200	00	6,8	6	40,8	37,9	38,0
AYPC.F50.0404		1,050	-	-	-	-	240,8	3,887	11202300	00	6,8	4	27,2	29,95	30,0
AYPC.F50.0405		0,809	-	-	-	-	201,7	2,998	11206700	00	6,8	6	40,8	33,3	33,8
AYPC.F50.0410		0,959	-	-	-	-	264,1	3,553	11251200	00	6,8	6	40,8	39,1	39,2
AYPC.F50.0407		2,250	27,85	6,30	46,2	20,8	403,7	8,334	11206800	00	6,8	2	13,6	31,5	31,9

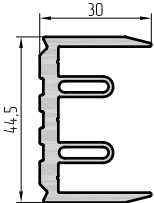
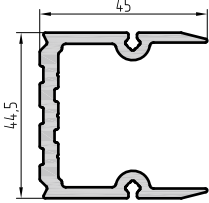
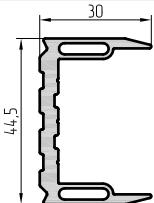
Article Drawing	Weight, kg/m	J <sub>x</sub> , cm <sup>4</sup>	W <sub>x</sub> , cm <sup>3</sup>	J <sub>y</sub> , cm <sup>4</sup>	W <sub>y</sub> , cm <sup>3</sup>	External perimeter, mm	Cross sectional area, cm <sup>2</sup>	Codes	Profile colour	Bar length, m	Quantity in package		Weight of package	
											pcs	m	net, kg	gross, kg
AYPC.F50.0406 	5,862	522,96	63,54	54,18	24,35	488,7	21,711	11202400	00	3,4	2	6,8	39,4	39,5
AYPC.F50.0408 	5,006	383,37	50,98	55,62	25,00	399,3	18,541	11250300	00	3,4	2	6,8	34,0	34,1
AYPC.F50.0409 	0,666	-	-	-	-	100,6	2,467	11250400	00	3,4	4	13,6	9,4	9,4
AYPC.F50.0416 	0,296	-	-	-	-	49,6	1,096	11206900	00	3,3	15	49,5	14,7	14,8

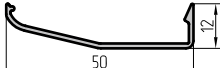
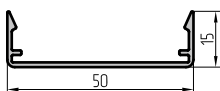
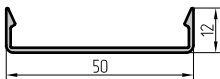
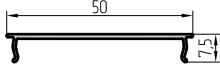
Article Drawing	Weight, kg/m	J <sub>x</sub> , cm <sup>4</sup>	W <sub>x</sub> , cm <sup>3</sup>	J <sub>y</sub> , cm <sup>4</sup>	W <sub>y</sub> , cm <sup>3</sup>	External perimeter, mm	Cross sectional area, cm <sup>2</sup>	Codes	Profile colour	Bar length, m	Quantity in package		Weight of package	
											pcs	m	net, kg	gross, kg
AYPC.F50.0412 	1,069	-	-	-	-	252,9	3,959	11255000	00	6,8	4	27,2	29,1	29,1
AYPC.F50.0413 	1,212	-	-	-	-	287,2	4,488	11255100	00	6,8	4	27,2	33,0	33,0
AYPC.F50.0414 	0,847	-	-	-	-	199,1	3,139	11255200	00	6,8	6	27,2	34,6	34,6
AYPC.F50.0501 	0,132	-	-	-	-	75,4	0,470	11202500 11202521 11202524 11202530 11202531 112025808	00 RAL9016 RAL8014 RAL8017 RAL9006 A00-D6	6,8	20	136	18,0 20,0 20,0 20,0 20,0 18,0	18,3 20,4 20,4 20,4 20,4 18,3
AYPC.F50.0502 	0,230	-	-	-	-	133,6	0,852	11202600 11202621 11202624 11202630 11202631 112026808	00 RAL9016 RAL8014 RAL8017 RAL9006 A00-D6	6,8	10	68	15,6 17,5 17,5 17,5 17,5 15,6	16,1 18,0 18,0 18,0 18,0 16,1
AYPC.F50.0503 	0,286	-	-	-	-	165,1	1,059	11202700 11202721 11202724 11202730 11202731 112027808	00 RAL9016 RAL8014 RAL8017 RAL9006 A00-D6	6,8	20	136	38,9 43,4 43,4 43,4 43,4 38,9	39,7 44,2 44,2 44,2 44,2 39,7
AYPC.F50.0504 	0,251	-	-	-	-	144,3	0,928	11202800 11202821 11202824 11202830 11202831 112028808	00 RAL9016 RAL8014 RAL8017 RAL9006 A00-D6	6,8	20	136	34,1 38,1 38,1 38,1 38,1 34,1	34,9 38,8 38,8 38,8 38,8 34,9
AYPC.F50.0511 	0,186	-	-	-	-	127,4	0,69	11254800 11254821 11254824 11254830 11254831 112548808	00 RAL9016 RAL8014 RAL8017 RAL9006 A00-D6	6,8	20	136	25,3 27,4 27,4 27,4 27,4 25,3	26,3 28,4 28,4 28,4 28,4 26,3

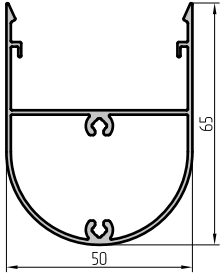
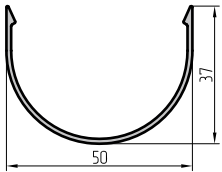
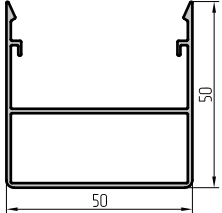
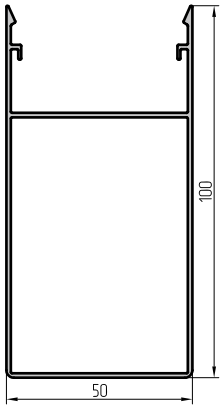
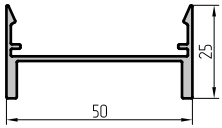
Article Drawing	Weight, kg/m	J <sub>x</sub> , cm <sup>4</sup>	W <sub>x</sub> , cm <sup>3</sup>	J <sub>y</sub> , cm <sup>4</sup>	W <sub>y</sub> , cm <sup>3</sup>	External perimeter, mm	Cross sectional area, cm <sup>2</sup>	Codes	Profile colour	Bar length, m	Quantity in package		Weight of package	
											pcs	m	net, kg	gross, kg
AYPC.F50.0505 	0,827	-	-	-	-	287,0	3,063	11202900	00	6,8	3	20,4	16,9	17,6
11202921								RAL9016	18,0				18,7	
11202924								RAL8014	18,0				18,7	
11202930								RAL8017	18,0				18,7	
11202931								RAL9006	18,0				18,7	
112029808								A00-D6	16,9				17,6	
AYPC.F50.0506 	0,359	-	-	-	-	203,5	1,331	11207000	00	6,8	3	20,4	7,3	7,9
11207021								RAL9016	8,2				8,7	
11207024								RAL8014	8,2				8,7	
11207030								RAL8017	8,2				8,7	
11207031								RAL9006	8,2				8,7	
112070808								A00-D6	7,3				7,9	
AYPC.F50.0508 	0,670	-	-	-	-	276,8	2,473	11250800	00	6,8	8	54,4	36,4	37,1
11250821								RAL9016	38,3				38,9	
11250824								RAL8014	38,3				38,9	
11250830								RAL8017	38,3				38,9	
11250831								RAL9006	38,3				38,9	
112508808								A00-D6	36,4				37,1	
AYPC.F50.0521 	0,992	-	-	-	-	376,7	3,673	11256200	00	6,8	4	27,2	18,3	19,5
11256221								RAL9016	19,5				20,7	
11256224								RAL8014	19,5				20,7	
11256230								RAL8017	19,5				20,7	
11256231								RAL9006	19,5				20,7	
112562808								A00-D6	18,3				19,5	
AYPC.F50.0515 	0,442	-	-	-	-	206,0	1,636	11255600	00	6,8	20	136	18,0	18,3
11255621								RAL9016	20,0				20,4	
11255624								RAL8014	20,0				20,4	
11255630								RAL8017	20,0				20,4	
11255631								RAL9006	20,0				20,4	
112556808								A00-D6	18,0				18,3	

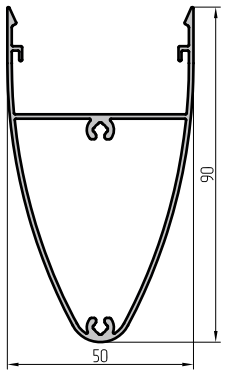
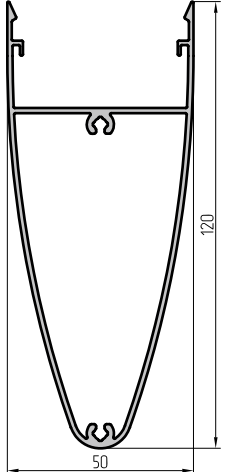
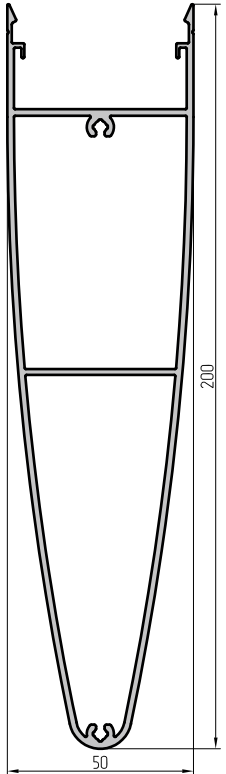

Article Drawing	Weight, kg/m	J <sub>x</sub> , cm <sup>4</sup>	W <sub>x</sub> , cm <sup>3</sup>	J <sub>y</sub> , cm <sup>4</sup>	W <sub>y</sub> , cm <sup>3</sup>	External perimeter, mm	Cross sectional area, cm <sup>2</sup>	Codes	Profile colour	Bar length, m	Quantity in package		Weight of package	
											pcs	m	net, kg	gross, kg
AYPC.F50.0507 	0,939	-	-	-	-	322,4	3,479	11203000	00	6,8	3	20,4	19,2	19,9
11203021								RAL9016	20,5				21,2	
11203024								RAL8014	20,5				21,2	
11203030								RAL8017	20,5				21,2	
11203031								RAL9006	20,5				21,2	
112030808								A00-D6	19,2				19,9	
AYPC.F50.0520 	1,274	-	-	-	-	380,8	4,718	11256100	00	6,8	2	13,6	17,3	18,2
11256121								RAL9016	17,9				18,8	
11256124								RAL8014	17,9				18,8	
11256130								RAL8017	17,9				18,8	
11256131								RAL9006	17,9				18,8	
112561808								A00-D6	17,3				18,2	
AYPC.F50.0509 	2,515	-	-	-	-	539,5	9,283	11251700	00	6,8	2	13,6	31,9	32,8
11251721								RAL9016	32,8				33,7	
11251724								RAL8014	32,8				33,7	
11251730								RAL8017	32,8				33,7	
11251731								RAL9006	32,8				33,7	
112517808								A00-D6	31,9				32,8	

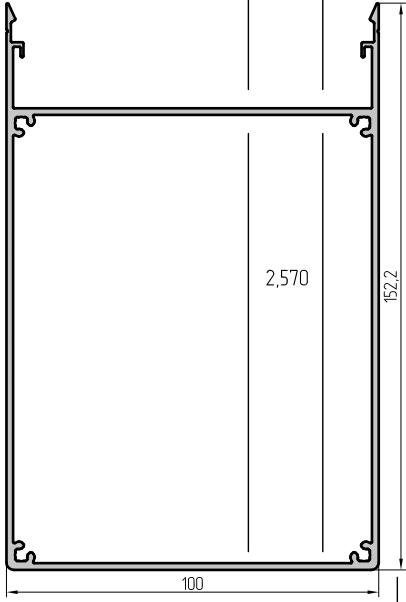
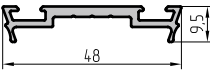
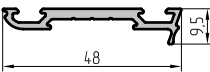
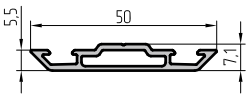
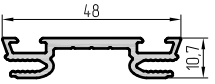
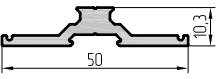
Article Drawing	Weight, kg/m	J <sub>x</sub> , cm <sup>4</sup>	W <sub>x</sub> , cm <sup>3</sup>	J <sub>y</sub> , cm <sup>4</sup>	W <sub>y</sub> , cm <sup>3</sup>	External perimeter, mm	Cross sectional area, cm <sup>2</sup>	Codes	Profile colour	Bar length, m	Quantity in package		Weight of package	
											pcs	m	net, kg	gross, kg
AYPC.F50.0510 	2,570	-	-	-	-	580,3	9,506	11251800 11251821 11251824 11251830 11251831 112518808	00 RAL9016 RAL8014 RAL8017 RAL9006 A00-D6	6,8	2	13,6	35,0 35,9 35,9 35,9 35,9 35,0	36,1 37,0 37,0 37,0 37,0 36,1
AYPC.F50.0601 	0,397	-	-	-	-	151,2	1,471	11203100	00	6,8	10	68	27,0	27,3
AYPC.F50.0602 	0,373	-	-	-	-	141,6	1,383	11203200	00	6,8	10	68	25,4	25,7
AYPC.F50.0620 	0,356	-	-	-	-	129,2	1,320	11209600 11209621 11209624 11209630 11209631 112096808	00 RAL9016 RAL8014 RAL8017 RAL9006 A00-D6	6,8	10	68	24,2 25,3 25,3 25,3 25,3 24,2	24,9 25,9 25,9 25,9 25,9 24,9
AYPC.F50.0621 	0,510	-	-	-	-	195,7	1,893	11251600	00	6,8	10	68	34,7	34,7
AYPC.F50.0622 	0,505	-	-	-	-	128,7	1,870	11252100 11252121 11252124 11252130 11252131 112521808	00 RAL9016 RAL8014 RAL8017 RAL9006 A00-D6	6,8	10	68,0	34,3 35,4 35,4 35,4 35,4 34,3	35,1 36,2 36,2 36,2 36,2 35,1

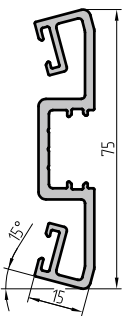
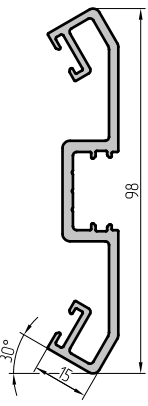
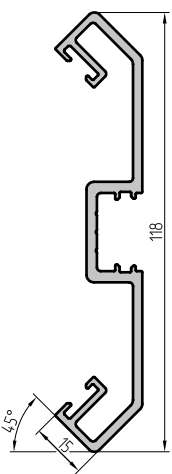
Article Drawing	Weight, kg/m	J <sub>x</sub> , cm <sup>4</sup>	W <sub>x</sub> , cm <sup>3</sup>	J <sub>y</sub> , cm <sup>4</sup>	W <sub>y</sub> , cm <sup>3</sup>	External perimeter, mm	Cross sectional area, cm <sup>2</sup>	Codes	Profile colour	Bar length, m	Quantity in package		Weight of package	
											pcs	m	net, kg	gross, kg
AYPC.F50.0605 	1,063	-	-	-	-	341,7	3,923	11203700 11203721 11203724 11203730 11203731 112037808	00 RAL9016 RAL8014 RAL8017 RAL9006 A00-D6	6,8	6	40,8	43,4 44,6 44,6 44,6 44,6 43,4	44,0 45,3 45,3 45,3 45,3 44,0
AYPC.F50.0606 	1,237	-	-	-	-	393,1	4,566	11203800 11203821 11203824 11203830 11203831 112038808	00 RAL9016 RAL8014 RAL8017 RAL9006 A00-D6	6,8	4	27,2	33,6 34,7 34,7 34,7 34,7 33,6	34,2 35,2 35,2 35,2 35,2 34,2
AYPC.F50.0607 	1,419	-	-	-	-	446,6	5,238	11203900 11203921 11203924 11203930 11203931 112039808	00 RAL9016 RAL8014 RAL8017 RAL9006 A00-D6	6,8	4	27,2	38,6 39,8 39,8 39,8 39,8 38,6	39,2 40,4 40,4 40,4 40,4 39,2

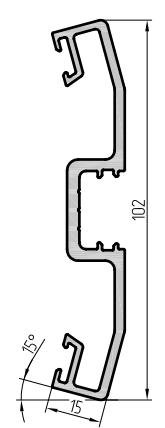
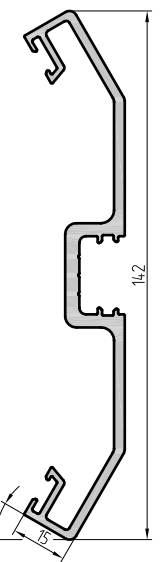
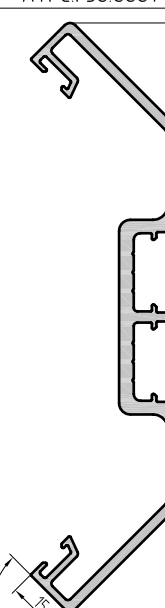
Article Drawing	Weight, kg/m	J <sub>x</sub> , cm <sup>4</sup>	W <sub>x</sub> , cm <sup>3</sup>	J <sub>y</sub> , cm <sup>4</sup>	W <sub>y</sub> , cm <sup>3</sup>	External perimeter, mm	Cross sectional area, cm <sup>2</sup>	Codes	Profile colour	Bar length, m	Quantity in package		Weight of package	
											pcs	m	net, kg	gross, kg
AYPC.F50.0605-01 	1,311	-	-	-	-	389,4	4,854	11253500 11253521 11253524 11253530 11253531 112535808	00 RAL9016 RAL8014 RAL8017 RAL9006 A00-D6	6,8	4	34,0	35,7 36,9 36,9 36,9 36,9 35,7	36,5 37,8 37,8 37,8 37,8 36,5
AYPC.F50.0606-01 	1,750	-	-	-	-	481,1	6,481	11253600 11253621 11253624 11253630 11253631 112536808	00 RAL9016 RAL8014 RAL8017 RAL9006 A00-D6	6,8	2	13,6	23,8 24,6 24,6 24,6 24,6 23,8	24,5 25,3 25,3 25,3 25,3 24,5
AYPC.F50.0607-01 	2,234	-	-	-	-	579,2	8,274	11253700 11253721 11253724 11253730 11253731 112537808	00 RAL9016 RAL8014 RAL8017 RAL9006 A00-D6	6,8	2	13,6	30,4 31,3 31,3 31,3 31,3 30,4	31,3 32,2 32,2 32,2 32,2 31,3

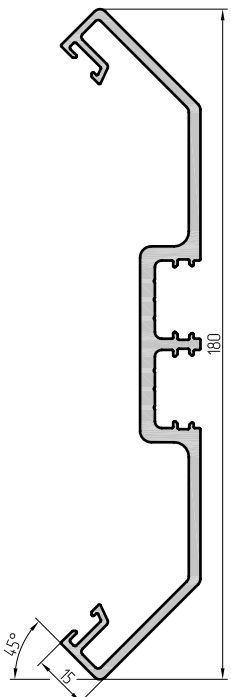
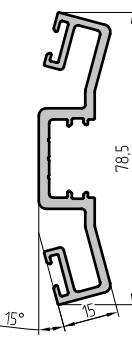
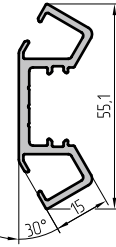
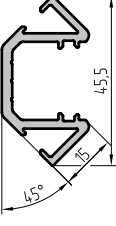
Article Drawing	Weight, kg/m	J <sub>x</sub> , cm <sup>4</sup>	W <sub>x</sub> , cm <sup>3</sup>	J <sub>y</sub> , cm <sup>4</sup>	W <sub>y</sub> , cm <sup>3</sup>	External perimeter, mm	Cross sectional area, cm <sup>2</sup>	Codes	Profile colour	Bar length, m	Quantity in package		Weight of package	
											pcs	m	net, kg	gross, kg
AYPC.F50.0607-02 	2,429	-	-	-	-	618,9	8,995	11253800 11253821 11253824 11253830 11253831 112538808	00 RAL9016 RAL8014 RAL8017 RAL9006 A00-D6	6,8	2	13,6	33,0 34,0 34,0 34,0 34,0 33,0	33,9 35,0 35,0 35,0 35,0 33,9
AYPC.F50.0608 	1,044	-	-	-	-	335,9	3,851	11204000 11204021 11204024 11204030 11204031 112040808	00 RAL9016 RAL8014 RAL8017 RAL9006 A00-D6	6,8	5	34,0	35,5 36,5 36,5 36,5 36,5 35,5	36,0 37,1 37,1 37,1 37,1 36,0
AYPC.F50.0609 	0,656	-	-	-	-	235,2	2,422	11204100 11204121 11204124 11204130 11204131 112041808	00 RAL9016 RAL8014 RAL8017 RAL9006 A00-D6	6,8	8	54,4	35,7 37,0 37,0 37,0 37,0 35,7	36,3 37,7 37,7 37,7 37,7 36,3
AYPC.F50.0610 	0,622	-	-	-	-	209,9	2,294	11204200 11204221 11204224 11204230 11204231 112042808	00 RAL9016 RAL8014 RAL8017 RAL9006 A00-D6	6,8	8	54,4	33,8 35,2 35,2 35,2 35,2 33,8	34,5 35,9 35,9 35,9 35,9 34,5

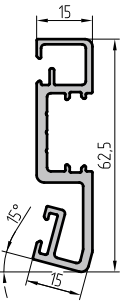
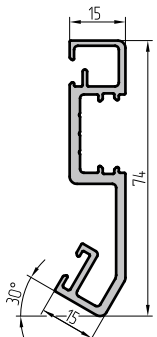
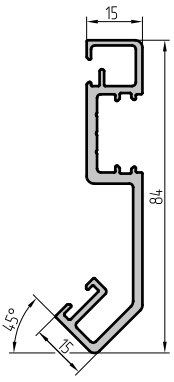
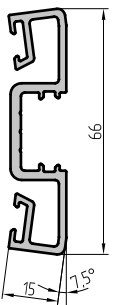

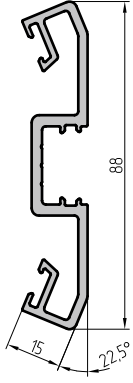
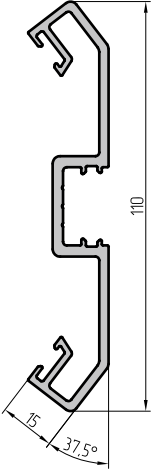
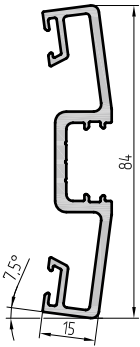

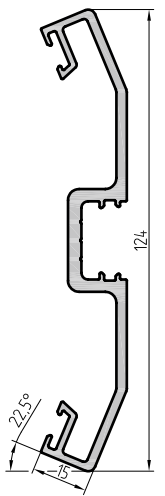
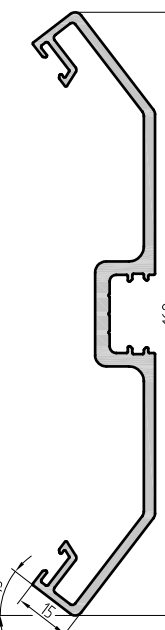
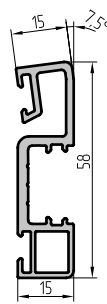

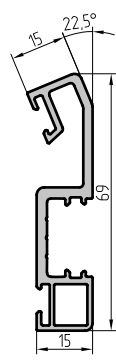
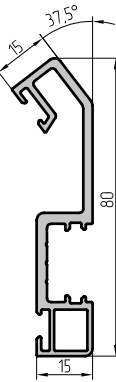
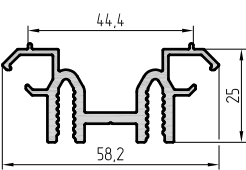
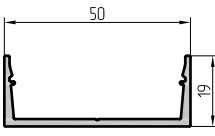

Article Drawing	Weight, kg/m	J <sub>x</sub> , cm <sup>4</sup>	W <sub>x</sub> , cm <sup>3</sup>	J <sub>y</sub> , cm <sup>4</sup>	W <sub>y</sub> , cm <sup>3</sup>	External perimeter, mm	Cross sectional area, cm <sup>2</sup>	Codes	Profile colour	Bar length, m	Quantity in package		Weight of package	
											pcs	m	net, kg	gross, kg
AYPC.F50.0611 	0,845	-	-	-	-	268,1	3,131	11207100	00	6,8	8	54,4	46,0	46,9
11207121								RAL9016	48,9				49,8	
11207124								RAL8014	48,9				49,8	
11207130								RAL8017	48,9				49,8	
11207131								RAL9006	48,9				49,8	
112071808								A00-D6	46,0				46,9	
AYPC.F50.0612 	0,932	-	-	-	-	293,8	3,452	11207200	00	6,8	8	54,4	50,7	51,7
11207221								RAL9016	53,9				54,9	
11207224								RAL8014	53,9				54,9	
11207230								RAL8017	53,9				54,9	
11207231								RAL9006	53,9				54,9	
112072808								A00-D6	50,7				51,7	
AYPC.F50.0613 	1,023	-	-	-	-	320,5	3,788	11207300	00	6,8	5	34,0	34,8	35,5
11207321								RAL9016	37,0				37,7	
11207324								RAL8014	37,0				37,7	
11207330								RAL8017	37,0				37,7	
11207331								RAL9006	37,0				37,7	
112073808								A00-D6	34,8				35,5	
AYPC.F50.0614 	0,894	-	-	-	-	318,5	3,313	11208900	00	6,8	5	34,0	30,4	31,0
11208921								RAL9016	31,7				32,3	
11208924								RAL8014	31,7				32,3	
11208930								RAL8017	31,7				32,3	
11208931								RAL9006	31,7				32,3	
112089808								A00-D6	30,4				31,0	

Article Drawing	Weight, kg/m	J <sub>x</sub> , cm <sup>4</sup>	W <sub>x</sub> , cm <sup>3</sup>	J <sub>y</sub> , cm <sup>4</sup>	W <sub>y</sub> , cm <sup>3</sup>	External perimeter, mm	Cross sectional area, cm <sup>2</sup>	Codes	Profile colour	Bar length, m	Quantity in package		Weight of package	
											pcs	m	net, kg	gross, kg
AYPC.F50.0615 	1,141	-	-	-	-	364,2	4,227	11209100 11209121 11209124 11209130 11209131 112091808	00 RAL9016 RAL8014 RAL8017 RAL9006 A00-D6	6,8	5	34,0	38,8 40,3 40,3 40,3 40,3 38,8	39,5 41,0 41,0 41,0 41,0 39,5
AYPC.F50.0616 	1,322	-	-	-	-	417,8	4,898	11209200 11209221 11209224 11209230 11209231 112092808	00 RAL9016 RAL8014 RAL8017 RAL9006 A00-D6	6,8	5	34,0	44,9 46,7 46,7 46,7 46,7 44,9	45,9 47,6 47,6 47,6 47,6 45,9
AYPC.F50.0614-01 	1,138	-	-	-	-	351,2	4,214	11253900 11253921 11253924 11253930 11253931 112539808	00 RAL9016 RAL8014 RAL8017 RAL9006 A00-D6	6,8	4	27,2	31,0 32,1 32,1 32,1 32,1 31,0	31,7 32,8 32,8 32,8 32,8 31,7



Article Drawing	Weight, kg/m	J <sub>x</sub> , cm <sup>4</sup>	W <sub>x</sub> , cm <sup>3</sup>	J <sub>y</sub> , cm <sup>4</sup>	W <sub>y</sub> , cm <sup>3</sup>	External perimeter, mm	Cross sectional area, cm <sup>2</sup>	Codes	Profile colour	Bar length, m	Quantity in package		Weight of package	
											pcs	m	net, kg	gross, kg
AYPC.F50.0615-01 	1,539	-	-	-	-	438,0	5,700	11254000 11254021 11254024 11254030 11254031 112540808	00 RAL9016 RAL8014 RAL8017 RAL9006 A00-D6	6,8	4	27,2	41,9 43,2 43,2 43,2 43,2 41,9	42,8 44,2 44,2 44,2 44,2 42,8
AYPC.F50.0616-01 	2,004	-	-	-	-	533,3	7,423	11254100 11254121 11254124 11254130 11254131 112541808	00 RAL9016 RAL8014 RAL8017 RAL9006 A00-D6	6,8	2	13,6	27,3 28,1 28,1 28,1 28,1 27,3	28,1 28,9 28,9 28,9 28,9 28,1
AYPC.F50.0617 	0,845	-	-	-	-	268,1	3,131	11209300 11209321 11209324 11209330 11209331 112093808	00 RAL9016 RAL8014 RAL8017 RAL9006 A00-D6	6,8	5	34,0	25,9 27,0 27,0 27,0 27,0 25,9	26,5 27,6 27,6 27,6 27,6 26,5

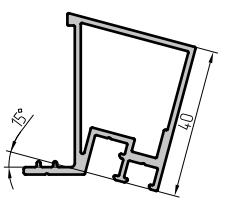
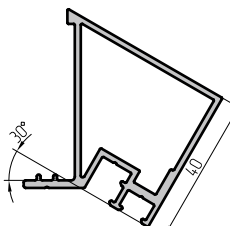
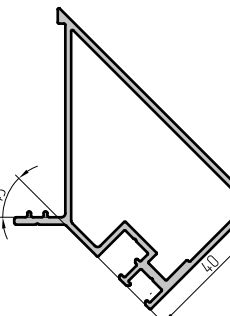
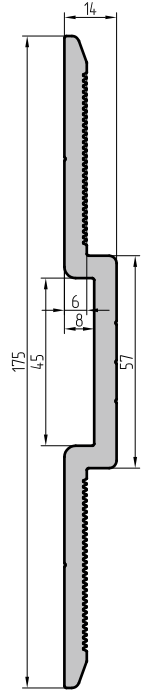

Article Drawing	Weight, kg/m	J <sub>x</sub> , cm <sup>4</sup>	W <sub>x</sub> , cm <sup>3</sup>	J <sub>y</sub> , cm <sup>4</sup>	W <sub>y</sub> , cm <sup>3</sup>	External perimeter, mm	Cross sectional area, cm <sup>2</sup>	Codes	Profile colour	Bar length, m	Quantity in package		Weight of package	
											pcs	m	net, kg	gross, kg
AYPC.F50.0618 	0,886	-	-	-	-	318,9	3,283	11209400 11209421 11209424 11209430 11209431 112094808	00 RAL9016 RAL8014 RAL8017 RAL9006 A00-D6	6,8	5	34,0	30,1 31,3 31,3 31,3 31,3 30,1	30,8 31,9 31,9 31,9 31,9 30,8
AYPC.F50.0619 	0,977	-	-	-	-	345,6	3,618	11209500 11209521 11209524 11209530 11209531 112095808	00 RAL9016 RAL8014 RAL8017 RAL9006 A00-D6	6,8	5	34,0	33,2 34,5 34,5 34,5 34,5 33,2	33,9 35,1 35,1 35,1 35,1 33,9
AYPC.F50.0715 	0,935	-	-	-	-	318,0	3,464	11254200 11254221 11254224 11254230 11254231 112542808	00 RAL9016 RAL8014 RAL8017 RAL9006 A00-D6	6,8	2	13,6	12,7 13,2 13,2 13,2 13,2 12,7	13,1 13,6 13,6 13,6 13,6 13,1
AYPC.F50.0725 	0,450	-	-	-	-	173,5	1,666	11254900 11254921 11254924 11254930 11254931 112549808	00 RAL9016 RAL8014 RAL8017 RAL9006 A00-D6	6,8	10	68	30,6 32,0 32,0 32,0 32,0 30,6	30,7 32,1 32,1 32,1 32,1 30,7

Article Drawing	Weight, kg/m	J <sub>x</sub> , cm <sup>4</sup>	W <sub>x</sub> , cm <sup>3</sup>	J <sub>y</sub> , cm <sup>4</sup>	W <sub>y</sub> , cm <sup>3</sup>	External perimeter, mm	Cross sectional area, cm <sup>2</sup>	Codes	Profile colour	Bar length, m	Quantity in package		Weight of package	
											pcs	m	net, kg	gross, kg
AYPC.F50.0701 	0,095	-	-	-	-	52,7	0,350	11204300	00	6,8	60	408	38,8	39,3
								11204321	RAL9016				40,8	41,4
								11204324	RAL8014				40,8	41,4
								11204330	RAL8017				40,8	41,4
								11204331	RAL9006				40,8	41,4
112043808	A00-D6	38,8	39,3											
AYPC.F50.0702 	0,140	-	-	-	-	76,7	0,517	11207400	00	6,8	25	170	23,8	24,3
								11207421	RAL9016				26,4	26,9
								11207424	RAL8014				26,4	26,9
								11207430	RAL8017				26,4	26,9
								11207431	RAL9006				26,4	26,9
112074808	A00-D6	23,8	24,3											
AYPC.F50.0712 	0,100	-	-	-	-	55,9	0,372	11209700	00	6,8	12	81,6	8,2	8,5
								11209721	RAL9016				8,7	9,1
								11209724	RAL8014				8,7	9,1
								11209730	RAL8017				8,7	9,1
								11209731	RAL9006				8,7	9,1
112097808	A00-D6	8,2	8,5											
AYPC.F50.0705 	0,107	-	-	-	-	59,6	0,397	11204400	00	6,8	60	408	43,7	44,2
								11204421	RAL9016				46,9	47,5
								11204424	RAL8014				46,9	47,5
								11204430	RAL8017				46,9	47,5
								11204431	RAL9006				46,9	47,5
112044808	A00-D6	43,7	44,2											
AYPC.F50.0713 	0,115	-	-	-	-	63,9	0,426	11209800	00	6,8	10	68	7,8	8,2
								11209821	RAL9016				8,3	8,7
								11209824	RAL8014				8,3	8,7
								11209830	RAL8017				8,3	8,7
								11209831	RAL9006				8,3	8,7
112098808	A00-D6	7,8	8,2											
AYPC.F50.0706 	0,125	-	-	-	-	68,7	0,460	11204500	00	6,8	50	340	42,5	43,0
								11204521	RAL9016				45,5	46,0
								11204524	RAL8014				45,5	46,0
								11204530	RAL8017				45,5	46,0
								11204531	RAL9006				45,5	46,0
112045808	A00-D6	42,5	43,0											
AYPC.F50.0714 	0,135	-	-	-	-	74,4	0,500	11209900	00	6,8	10	68	9,2	9,5
								11209921	RAL9016				9,8	10,1
								11209924	RAL8014				9,8	10,1
								11209930	RAL8017				9,8	10,1
								11209931	RAL9006				9,8	10,1
112099808	A00-D6	9,2	9,5											
AYPC.F50.0707 	0,148	-	-	-	-	81,4	0,548	11204600	00	6,8	40	272	40,3	40,8
								11204621	RAL9016				43,0	43,5
								11204624	RAL8014				43,0	43,5
								11204630	RAL8017				43,0	43,5
								11204631	RAL9006				43,0	43,5
112046808	A00-D6	40,3	40,8											
AYPC.F50.0711 	0,122	-	-	-	-	61,6	0,451	11207500	00	6,8	20	136	16,6	17,1
								11207521	RAL9016				18,3	18,8
								11207524	RAL8014				18,3	18,8
								11207530	RAL8017				18,3	18,8
								11207531	RAL9006				18,3	18,8
112075808	A00-D6	16,6	17,1											

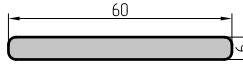
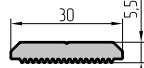
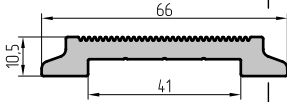
Article	Drawing	Weight, kg/m	J <sub>x</sub> , cm <sup>4</sup>	W <sub>x</sub> , cm <sup>3</sup>	J <sub>y</sub> , cm <sup>4</sup>	W <sub>y</sub> , cm <sup>3</sup>	External perimeter, mm	Cross sectional area, cm <sup>2</sup>	Codes	Profile colour	Bar length, m	Quantity in package		Weight of package	
												pcs	m	net, kg	gross, kg
AYPC.F50.0708		0,819	-	-	-	-	214,0	3,021	11204700	00	6,8	4	27,2	22,3	22,9
	11204721								RAL9016	23,4				24,1	
	11204724								RAL8014	23,4				24,1	
	11204730								RAL8017	23,4				24,1	
	11204731								RAL9006	23,4				24,1	
	112047808								A00-D6	22,3				22,9	
AYPC.F50.0709		0,883	-	-	-	-	229,6	3,259	11204800	00	6,8	4	27,2	24,0	24,8
	11204821								RAL9016	25,3				26,0	
	11204824								RAL8014	25,3				26,0	
	11204830								RAL8017	25,3				26,0	
	11204831								RAL9006	25,3				26,0	
	112048808								A00-D6	24,0				24,8	
AYPC.F50.0710		1,078	-	-	-	-	276,4	3,977	11204900	00	6,8	4	27,2	29,3	30,1
	11204921								RAL9016	30,8				31,6	
	11204924								RAL8014	30,8				31,6	
	11204930								RAL8017	30,8				31,6	
	11204931								RAL9006	30,8				31,6	
	112049808								A00-D6	29,3				30,1	
AYPC.F50.0723		2,899	-	-	-	-	454,6	10,737	11250600	00	3,4	2	6,8	19,7	19,7

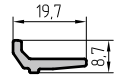
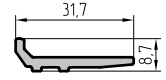
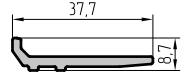
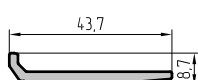
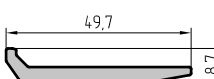
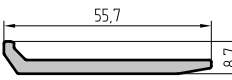
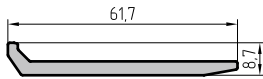
Article Drawing	Weight, kg/m	J <sub>x</sub> , cm <sup>4</sup>	W <sub>x</sub> , cm <sup>3</sup>	J <sub>y</sub> , cm <sup>4</sup>	W <sub>y</sub> , cm <sup>3</sup>	External perimeter, mm	Cross sectional area, cm <sup>2</sup>	Codes	Profile colour	Bar length, m	Quantity in package		Weight of package	
											pcs	m	net, kg	gross, kg
AYPC.F50.0721 	0,963	-	-	-	-	128,6	3,566	11209000	00	3,4	10	34	32,7	32,9
AYPC.F50.0722 	0,381	-	-	-	-	85,2	1,412	11250500	00	3,4	10	34	13,0	13,1
AYPC.F50.0724 	1,100	-	-	-	-	190,8	4,074	11250700	00	3,4	5	17	18,7	18,7
AYPC.F50.0801 	0,117	-	-	-	-	39,3	0,431	11203300	00	6,8	20	136	15,9	16,0
AYPC.F50.0807 	0,159	-	-	-	-	51,2	0,591	11208400	00	6,8	20	136	15,9	16,0
AYPC.F50.0802 	0,255	-	-	-	-	76,6	0,941	11203400	00	6,8	20	136	34,68	34,7
AYPC.F50.0803 	0,299	-	-	-	-	86,6	1,103	11203500	00	6,8	20	136	40,66	40,7
AYPC.F50.0804 	0,343	-	-	-	-	100,6	1,265	11203600	00	6,8	20	136	46,65	46,7
AYPC.F50.0805 	0,500	-	-	-	-	110,0	1,853	11250100	00	6,8	10	68	34,0	34,0
AYPC.F50.0806 	0,560	-	-	-	-	122,0	2,075	11250200	00	6,8	10	68	38,1	38,1
AYPC.F50.0814 	0,620	-	-	-	-	134,0	2,297	11251300	00	6,8	10	68	42,2	42,2

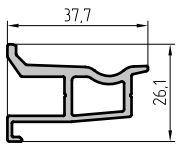
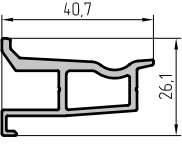
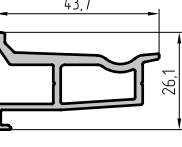
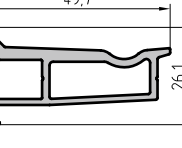
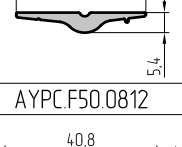
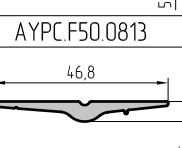
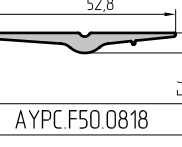
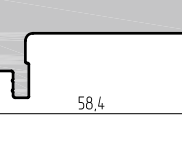
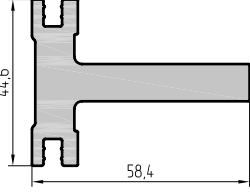
Article Drawing	Weight, kg/m	J <sub>x</sub> , cm <sup>4</sup>	W <sub>x</sub> , cm <sup>3</sup>	J <sub>y</sub> , cm <sup>4</sup>	W <sub>y</sub> , cm <sup>3</sup>	External perimeter, mm	Cross sectional area, cm <sup>2</sup>	Codes	Profile colour	Bar length, m	Quantity in package		Weight of package	
											pcs	m	net, kg	gross, kg
AYPC.F50.0808 	0,561	-	-	-	-	155,9	2,078	11207600	00	6,8	6	40,8	22,9	23,3
AYPC.F50.0809 	0,597	-	-	-	-	213,8	2,213	11208500	00	6,8	6	40,8	24,4	24,4
AYPC.F50.0810 	0,634	-	-	-	-	255,9	2,347	11208600	00	6,8	6	40,8	25,8	25,8
AYPC.F50.0816 	0,746	-	-	-	-	179,9	2,762	11251400	00	6,8	6	40,8	30,4	30,5
AYPC.F50.0811 	0,246	-	-	-	-	75,6	0,911	11207700	00	6,8	12	81,6	20,1	20,4
AYPC.F50.0812 	0,290	-	-	-	-	87,3	1,076	11208700	00	6,8	12	81,6	23,7	23,7
AYPC.F50.0813 	0,332	-	-	-	-	99,4	1,229	11208800	00	6,8	12	81,6	27,1	27,1
AYPC.F50.0817 	0,360	-	-	-	-	110,9	1,335	11251500	00	6,8	12	81,6	29,4	29,4
AYPC.F50.0818 	2,443	-	-	-	-	236,0	9,049	11252200	00	6,8	2	13,6	33,2	33,3

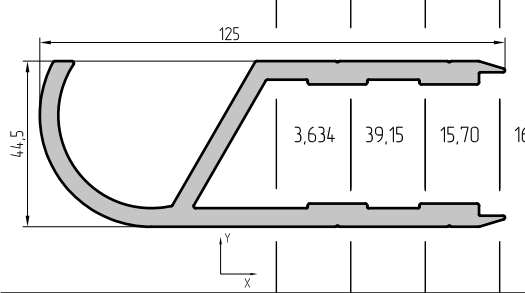
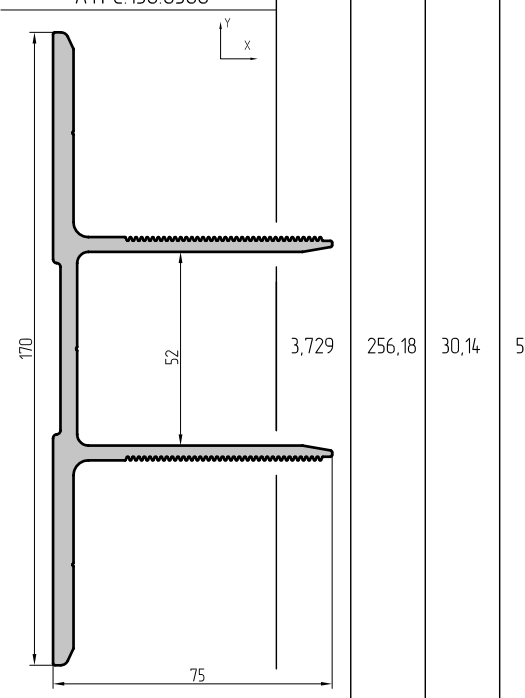
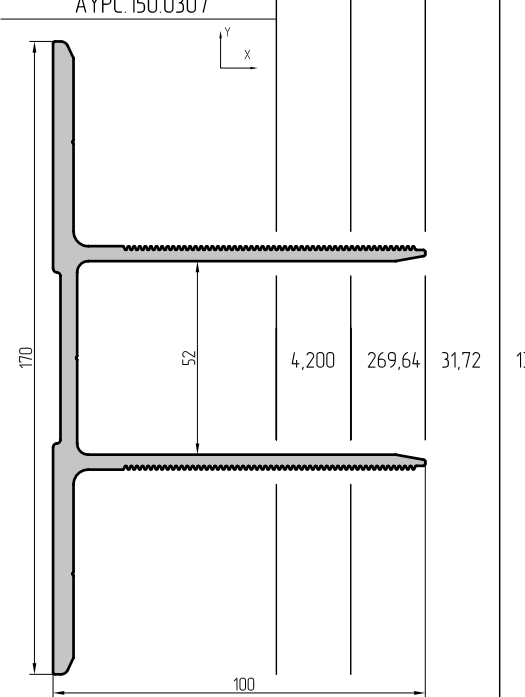
Article	Drawing	Weight, kg/m	J <sub>x</sub> , cm <sup>4</sup>	W <sub>x</sub> , cm <sup>3</sup>	J <sub>y</sub> , cm <sup>4</sup>	W <sub>y</sub> , cm <sup>3</sup>	External perimeter, mm	Cross sectional area, cm <sup>2</sup>	Codes	Profile colour	Bar length, m	Quantity in package		Weight of package	
												pcs	m	net, kg	gross, kg
AYPC.F50.6005		3,634	39,15	15,70	168,94	26,60	535,4	13,458	11600500	00	3,4	2	6,8	24,7	24,7
AYPC.150.0306		3,729	256,18	30,14	58,77	9,89	694,7	13,812	11801900	00	3,0	2	6	22,4	22,4
AYPC.150.0307		4,200	269,64	31,72	135,65	17,97	833,2	15,556	11802000	00	3,0	2	6	25,2	25,2

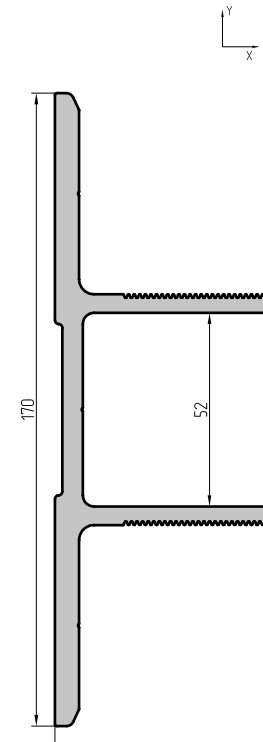
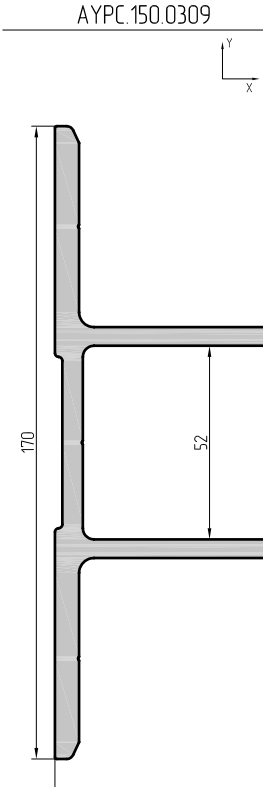
Article	Drawing	Weight, kg/m	J <sub>x</sub> , cm <sup>4</sup>	W <sub>x</sub> , cm <sup>3</sup>	J <sub>y</sub> , cm <sup>4</sup>	W <sub>y</sub> , cm <sup>3</sup>	External perimeter, mm	Cross sectional area, cm <sup>2</sup>	Codes	Profile colour	Bar length, m	Quantity in package		Weight of package	
												pcs	m	net, kg	gross, kg
AYPC.150.0308		6,112	355,65	41,84	439,93	43,91	1052,4	22,639	11802100	00	3,0	2	6	36,7	36,7
AYPC.150.0309		7,193	388,22	45,67	883,86	71,16	1212,4	26,639	11802200	00	3,0	2	6	43,2	43,2







**ALUFACH ALT F50**  
CURTAIN WALL  
SYSTEM

## ACCESSORIES



03

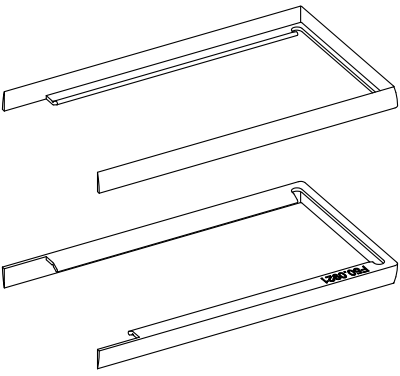
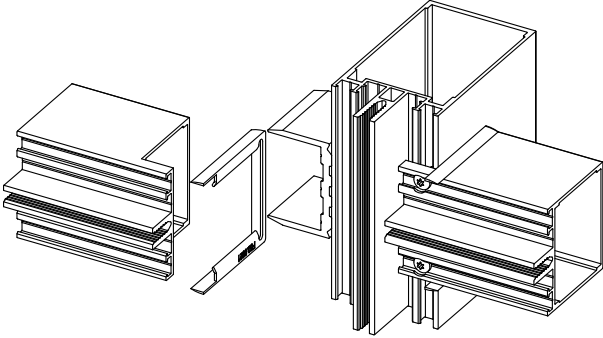
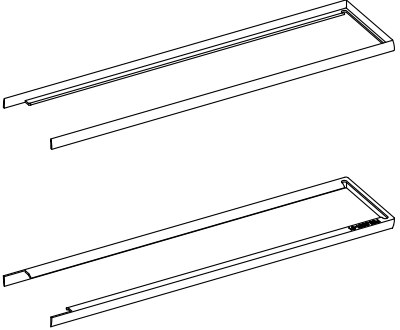
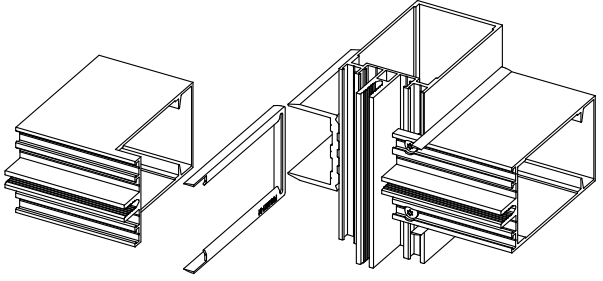
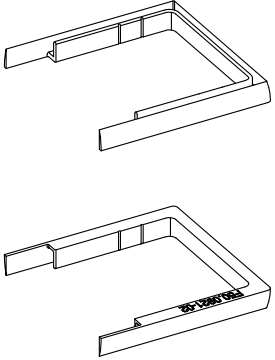
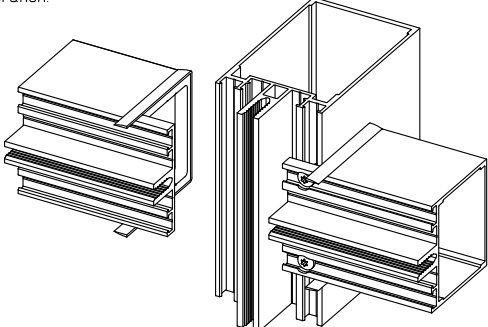
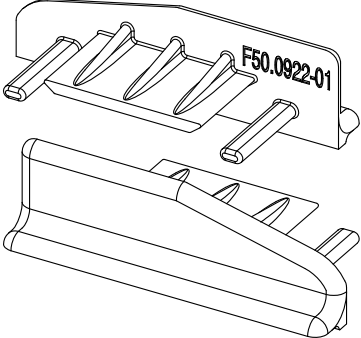
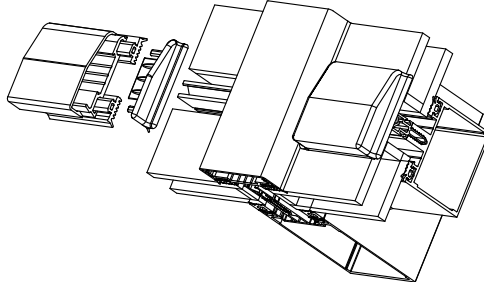

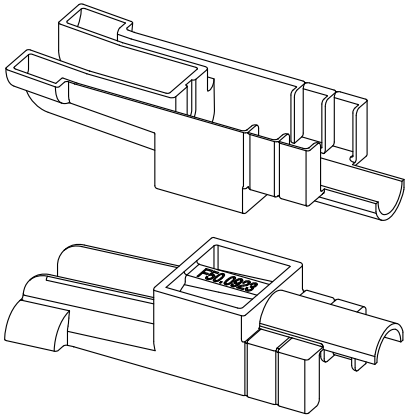
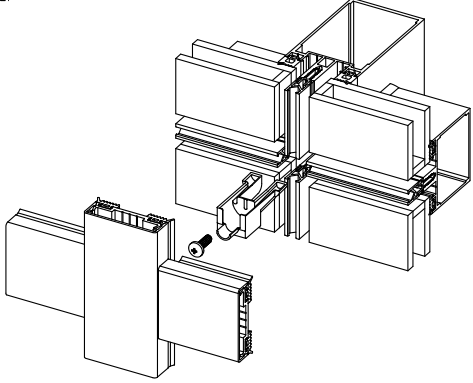
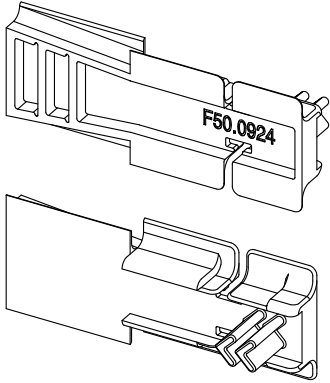
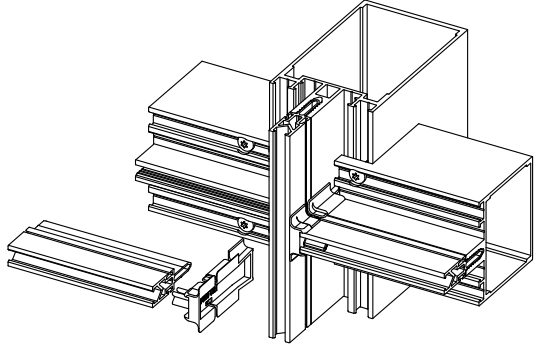
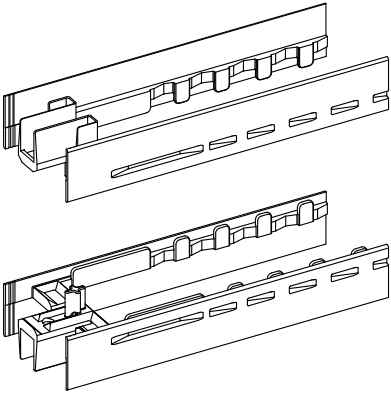
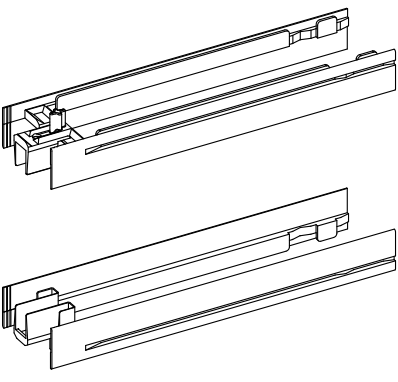
Drawing	Code	Colour	Article	Description						
	11212100	Black	AYPC.F50.0921	AYPC.F50.0921 plug is mounted on transoms edges and is used for decoration 						
	11212101	White								
Qty in pack - 100 pcs				For transom <table border="1" style="display: inline-table; vertical-align: middle;"> <tr> <td>AYPC.F50.0202</td> <td>AYPC.F50.0203</td> <td>AYPC.F50.0204</td> </tr> <tr> <td>AYPC.F50.0205</td> <td>AYPC.F50.0206</td> <td>AYPC.F50.0214</td> </tr> </table>	AYPC.F50.0202	AYPC.F50.0203	AYPC.F50.0204	AYPC.F50.0205	AYPC.F50.0206	AYPC.F50.0214
AYPC.F50.0202	AYPC.F50.0203	AYPC.F50.0204								
AYPC.F50.0205	AYPC.F50.0206	AYPC.F50.0214								
	11212800	Black	AYPC.F50.0921-01	AYPC.F50.0921-01 plug is mounted on transoms edges and is used for decoration. 						
	11212801	White								
Qty in pack - 50 pcs				For transom <table border="1" style="display: inline-table; vertical-align: middle;"> <tr> <td>AYPC.F50.0207</td> <td>AYPC.F50.0208</td> <td>AYPC.F50.0209</td> <td>AYPC.F50.0210</td> <td>AYPC.F50.0211</td> </tr> </table>	AYPC.F50.0207	AYPC.F50.0208	AYPC.F50.0209	AYPC.F50.0210	AYPC.F50.0211	
AYPC.F50.0207	AYPC.F50.0208	AYPC.F50.0209	AYPC.F50.0210	AYPC.F50.0211						
	11212000	Black	AYPC.F50.0921-02	AYPC.F50.0921-02 plug is mounted on transoms edges and is used for decoration. 						
	11212001	White								
Qty in pack - 100 pcs				<table border="1" style="display: inline-table; vertical-align: middle;"> <tr> <td>AYPC.F50.0202</td> <td>AYPC.F50.0203</td> <td>AYPC.F50.0204</td> <td>-</td> <td>-</td> </tr> </table>	AYPC.F50.0202	AYPC.F50.0203	AYPC.F50.0204	-	-	
AYPC.F50.0202	AYPC.F50.0203	AYPC.F50.0204	-	-						
	11212200	Black	AYPC.F50.0922	AYPC.F50.0922 plug is mounted on the edges of clamp and cover profile. It is intended for moisture removal from outside of glass unit on inclined facade. 						
	11212201	White								
Kit (left, right) Qty in pack - 50 kits				<table border="1" style="display: inline-table; vertical-align: middle;"> <tr> <td>For decorative cover profile</td> <td>For clamp profile</td> </tr> <tr> <td>AYPC.F50.0502</td> <td>AYPC.F50.0602</td> </tr> </table>	For decorative cover profile	For clamp profile	AYPC.F50.0502	AYPC.F50.0602		
For decorative cover profile	For clamp profile									
AYPC.F50.0502	AYPC.F50.0602									

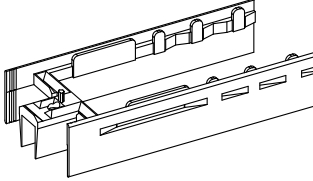
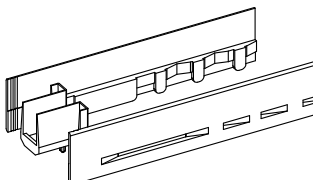
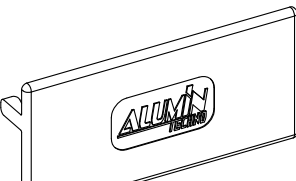
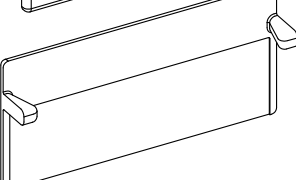
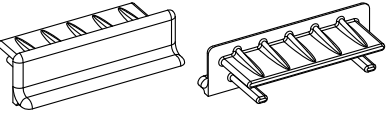
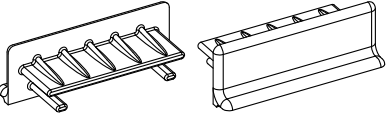
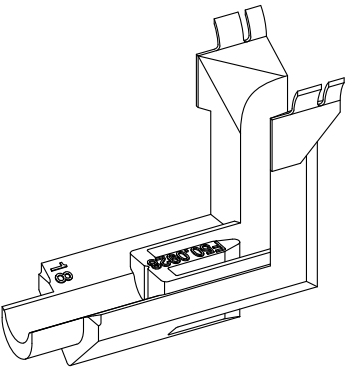
Drawing	Code	Colour	Article	Description												
 <p>Qty in pack - 50 pcs</p>	11212300	Black	AYPC.F50.0923	<p>AYPC.F50.0923 drip drain is mounted onto a mullion and is intended for moisture removal. It provides air circulation and levelling of vapour pressure.</p> 												
 <p>Qty in pack - 100 pcs</p>	11212400	Black	AYPC.F50.0924	<p>AYPC.F50.0924 plug is mounted onto a transom in the thermal break groove. It is intended for moisture removal and provides air circulation and levelling of vapour pressure.</p> 												
 <p>Qty in pack - 40 pcs</p>	11212500	Black	AYPC.F50.0925	<p>AYPC.F50.0925, AYPC.F50.0925-01 plugs are mounted vertically onto the junction of two mullions. It provides moisture removal and is used for decoration. AYPC.F50.0926 plug is mounted to the edge of AYPC.F50.0925 and AYPC.F50.0925-01.</p> <table border="1"> <thead> <tr> <th colspan="2">For mullion profile</th> </tr> </thead> <tbody> <tr> <td>AYPC.F50.0102</td> <td>-</td> </tr> <tr> <td>AYPC.F50.0103</td> <td>AYPC.F50.0113 AYPC.F50.0123</td> </tr> <tr> <td>AYPC.F50.0104</td> <td>AYPC.F50.0114 AYPC.F50.0124</td> </tr> <tr> <td>AYPC.F50.0105</td> <td>AYPC.F50.0115 AYPC.F50.0125</td> </tr> <tr> <td>AYPC.F50.0106</td> <td>AYPC.F50.0116 AYPC.F50.0126</td> </tr> </tbody> </table>	For mullion profile		AYPC.F50.0102	-	AYPC.F50.0103	AYPC.F50.0113 AYPC.F50.0123	AYPC.F50.0104	AYPC.F50.0114 AYPC.F50.0124	AYPC.F50.0105	AYPC.F50.0115 AYPC.F50.0125	AYPC.F50.0106	AYPC.F50.0116 AYPC.F50.0126
For mullion profile																
AYPC.F50.0102	-															
AYPC.F50.0103	AYPC.F50.0113 AYPC.F50.0123															
AYPC.F50.0104	AYPC.F50.0114 AYPC.F50.0124															
AYPC.F50.0105	AYPC.F50.0115 AYPC.F50.0125															
AYPC.F50.0106	AYPC.F50.0116 AYPC.F50.0126															
	11212501	White														
 <p>Qty in pack - 40 pcs</p>	11212900	Black	AYPC.F50.0925-01	<table border="1"> <thead> <tr> <th colspan="2">For mullion profile</th> </tr> </thead> <tbody> <tr> <td>AYPC.F50.0107</td> <td>-</td> </tr> <tr> <td>AYPC.F50.0108</td> <td>-</td> </tr> </tbody> </table>	For mullion profile		AYPC.F50.0107	-	AYPC.F50.0108	-						
For mullion profile																
AYPC.F50.0107	-															
AYPC.F50.0108	-															
	11212901	White														

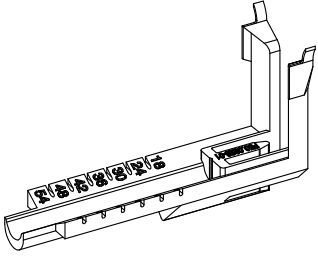
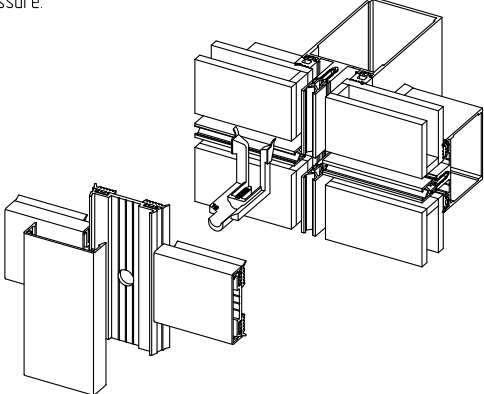
Drawing	Code	Colour	Article	Description
  Qty in pack - 40 pcs	11213200	Black	AYPC.F50.0925-03	For transom profile AYPC.F50.0205 - AYPC.F50.0206 - AYPC.F50.0207 - AYPC.F50.0226 - AYPC.F50.0227 -
	11213201	White		
  Qty in pack - 40 pcs	11212600	Black	AYPC.F50.0926	AYPC.F50.0926 plug is mounted at the edge of AYPC.F50.0925 and AYPC.F50.0925-01. It is used for decoration.
	11212601	White		
 Qty in pack - 100 pcs	11212700	Black	AYPC.F50.0927	AYPC.F50.0927 plug is mounted at the edges of clamp profile and decorative cover. It is used for decoration.
	11212701	White		
 Qty in pack - 100 pcs	11214000	Black	AYPC.F50.0927-01	For decorative cover profile AYPC.F50.0504 For clamp profile AYPC.F50.0601
	11214001	White		
 Qty in pack - 50 pcs	11213100	Black	AYPC.F50.0928	AYPC.F50.0928 drain is mounted on a mullion. It is intended for moisture removal. It provides air circulation and stabilizes vapour pressure.

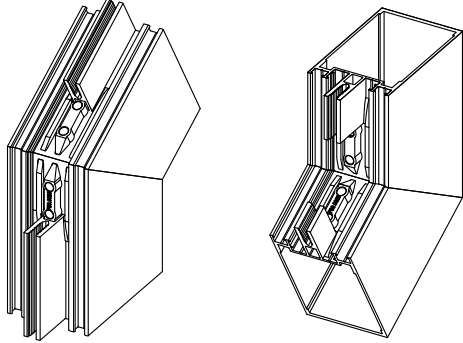
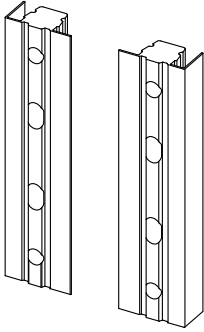
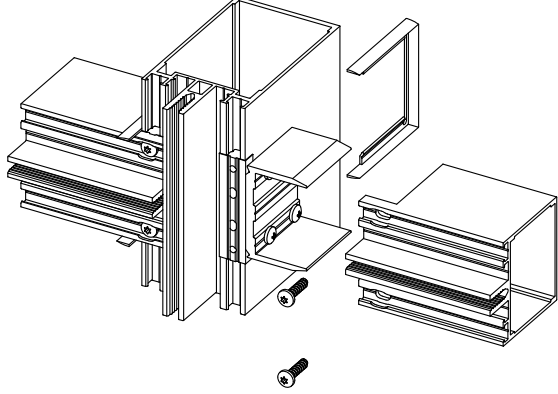
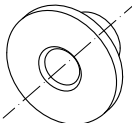
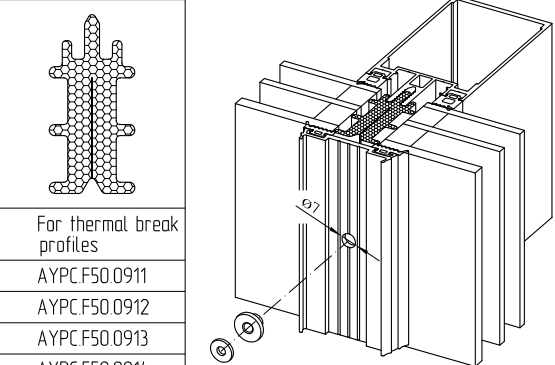
Drawing	Code	Colour	Article	Description
	11213300	Black	AYPC.F50.0928-01	<p>AYPC.F50.0928-01 drip drain is mounted onto a transom and is intended for moisture removal. It provides air circulation and levelling of vapour pressure.</p> 
Qty in pack - 50 pcs.				
	11213000	Black	AYPC.F50.0929	<p>AYPC.F50.0929 plastic detail is installed on mullions sharp turn. It ensures moisture transmission and junction impermeability.</p> 
Qty in pack - 24 pcs				
	11216400	Black	FRK42	<p>Sealing plate is intended for joint sealing of mullions and transoms.</p> 
Qty in pack - 200 pcs				
	11217500	Black	FRK151	<p>Rubber bush is designed to direct the clamping self-tapping screw while it comes through the foamed thermal break.</p>  <div style="border: 1px solid black; padding: 5px; width: fit-content;"> <p>For thermal break profiles</p> <ul style="list-style-type: none"> <li>AYPC.F50.0911</li> <li>AYPC.F50.0912</li> <li>AYPC.F50.0913</li> <li>AYPC.F50.0914</li> </ul> </div>
Qty in pack - 300 pcs				

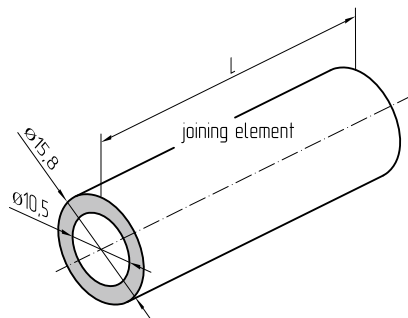

Joining element made of AYPF50.0416 profile

Code	Article	Length L, mm	Qty in pack, pcs	Colour
11225600	AYPC.F50.0950	50	100	00
11225700	AYPC.F50.0950-01	51	100	
11231200	AYPC.F50.0950-02	60	100	
11237400	AYPC.F50.0950-03	58	100	

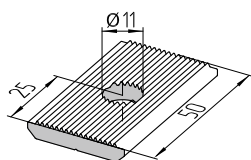

Washer made of AYPF50.0722 profile

Code	11229200
Article	AYPC.F50.2905
Qty in pack, pcs	100
Colour	00

for mullion-transom connection:  
- 6 mm notch;  
- 6 mm shaped notch

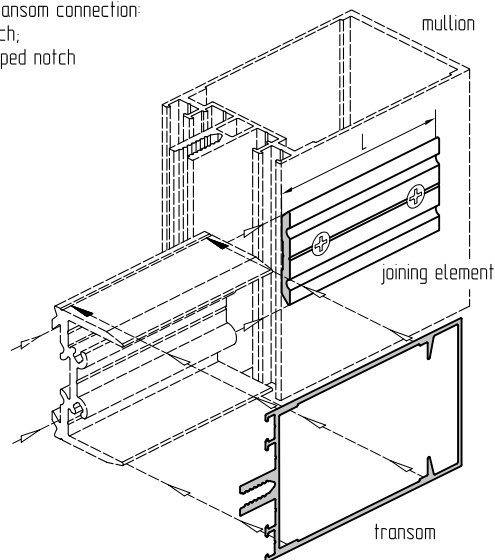

Joining element made of AYPF50.0402 profile

Code	Article	Length L, mm	for transom	for mullion used as transom	Colour	Qty in pack, pcs
11221100	AYPC.F50.0942	36	AYPC.F50.0204	-	00	100
11221200	AYPC.F50.0942-01	45	AYPC.F50.0205 AYPC.F50.0214	AYPC.F50.0102	00	100
11221300	AYPC.F50.0942-02	63	AYPC.F50.0206	AYPC.F50.0103	00	100
11222400	AYPC.F50.0942-03	83	AYPC.F50.0207	AYPC.F50.0104	00	100
11222500	AYPC.F50.0942-04	102	AYPC.F50.0208	AYPC.F50.0105	00	100
11222600	AYPC.F50.0942-05	122	AYPC.F50.0209	AYPC.F50.0106	00	50
11222700	AYPC.F50.0942-06	152	AYPC.F50.0210	AYPC.F50.0107	00	50
11222800	AYPC.F50.0942-07	181	AYPC.F50.0211	AYPC.F50.0108	00	50

for mullion-transom connection:  
- 6 mm notch;  
- 6 mm shaped notch

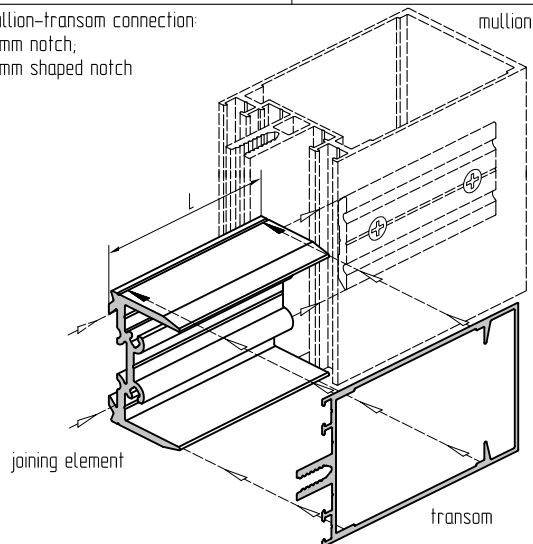

for mullion-transom connection:  
- 6 mm notch;  
- 6 mm shaped notch

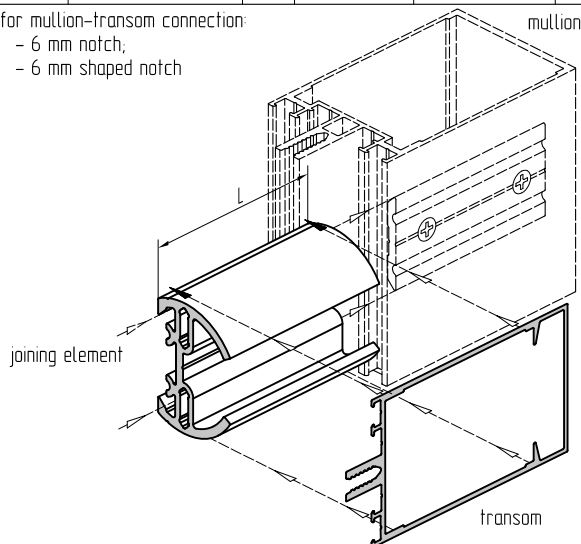

Joining element made of profile AYPF50.0403

Code	Article	Length L, mm	for transom	for mullion used as transom	Colour	Qty in pack, pcs
11221400	AYPC.F50.0943	16	AYPC.F50.0203	-	00	40
11221500	AYPC.F50.0943-01	36	AYPC.F50.0204	-	00	180
11221600	AYPC.F50.0943-02	45	AYPC.F50.0205 AYPC.F50.0214	AYPC.F50.0102	00	120
11221700	AYPC.F50.0943-03	63	AYPC.F50.0206	AYPC.F50.0103	00	72
11222900	AYPC.F50.0943-04	83	AYPC.F50.0207	AYPC.F50.0104	00	50
11223000	AYPC.F50.0943-05	102	AYPC.F50.0208	AYPC.F50.0105	00	48
11223100	AYPC.F50.0943-06	122	AYPC.F50.0209	AYPC.F50.0106	00	50
11223200	AYPC.F50.0943-07	152	AYPC.F50.0210	AYPC.F50.0107	00	40
11223300	AYPC.F50.0943-08	181	AYPC.F50.0211	AYPC.F50.0108	00	40

Joining element made of profile AYPF50.0404

Code	Article	Length L, mm	for transom	for mullion used as transom	Colour	Qty in pack, pcs
11221800	AYPC.F50.0944	16	AYPC.F50.0203	-	00	20
11221900	AYPC.F50.0944-01	36	AYPC.F50.0204	-	00	20
11222000	AYPC.F50.0944-02	45	AYPC.F50.0205 AYPC.F50.0214	AYPC.F50.0102	00	16
11222100	AYPC.F50.0944-03	63	AYPC.F50.0206	AYPC.F50.0103	00	30
11223400	AYPC.F50.0944-04	83	AYPC.F50.0207	AYPC.F50.0104	00	8
11223500	AYPC.F50.0944-05	102	AYPC.F50.0208	AYPC.F50.0105	00	4
11223600	AYPC.F50.0944-06	122	AYPC.F50.0209	AYPC.F50.0106	00	4
11223700	AYPC.F50.0944-07	152	AYPC.F50.0210	AYPC.F50.0107	00	4
11223800	AYPC.F50.0944-08	181	AYPC.F50.0211	AYPC.F50.0108	00	4

for mullion-transom connection:

- 6 mm notch;
- 6 mm shaped notch

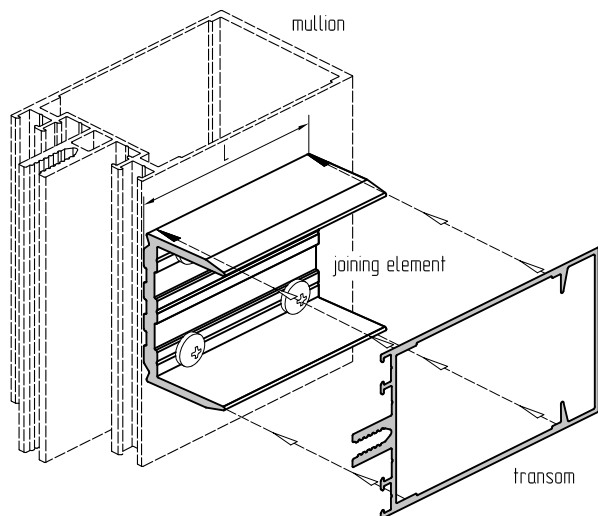

for mullion-transom connection:

- 6 mm notch;
- 6 mm shaped notch

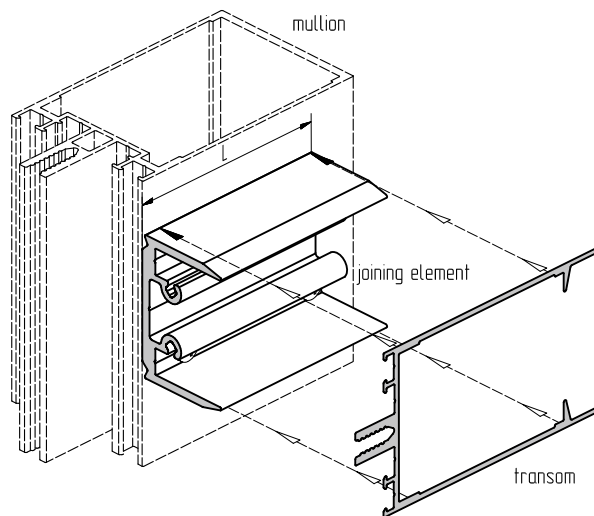

Joining element made of profile AYPF50.0405						Colour	00	Joining element made of profile AYPF50.0410						Colour	00
Code	Article	Length L, mm	for transom	for mullion used as transom	Qty in pack, pcs			Code	Article	Length L, mm	for transom	for mullion used as transom	Qty in pack, pcs		
11223900	AYPC.F50.0945	16	AYPC.F50.0203	-	50			11232200	AYPC.F50.0946	16	AYPC.F50.0203	-	50		
11224000	AYPC.F50.0945-01	36	AYPC.F50.0204	-	100			11232300	AYPC.F50.0946-01	36	AYPC.F50.0204	-	100		
11225800	AYPC.F50.0945-02	45	AYPC.F50.0205 AYPC.F50.0214	AYPC.F50.0102	100			11232400	AYPC.F50.0946-02	45	AYPC.F50.0205 AYPC.F50.0214	AYPC.F50.0102	100		
11225900	AYPC.F50.0945-03	63	AYPC.F50.0206	AYPC.F50.0103	72			11232500	AYPC.F50.0946-03	63	AYPC.F50.0206	AYPC.F50.0103	72		
11226000	AYPC.F50.0945-04	83	AYPC.F50.0207	AYPC.F50.0104	48			11232600	AYPC.F50.0946-04	83	AYPC.F50.0207	AYPC.F50.0104	48		
11226100	AYPC.F50.0945-05	102	AYPC.F50.0208	AYPC.F50.0105	48			11232700	AYPC.F50.0946-05	102	AYPC.F50.0208	AYPC.F50.0105	48		
11226200	AYPC.F50.0945-06	122	AYPC.F50.0209	AYPC.F50.0106	50			11232800	AYPC.F50.0946-06	122	AYPC.F50.0209	AYPC.F50.0106	50		
11226300	AYPC.F50.0945-07	152	AYPC.F50.0210	AYPC.F50.0107	40			11232900	AYPC.F50.0946-07	152	AYPC.F50.0210	AYPC.F50.0107	40		
11226400	AYPC.F50.0945-08	181	AYPC.F50.0211	AYPC.F50.0108	38			11233000	AYPC.F50.0946-08	181	AYPC.F50.0211	AYPC.F50.0108	38		

for mullion-transom connection:

- 6 mm notch;
- 6 mm shaped notch

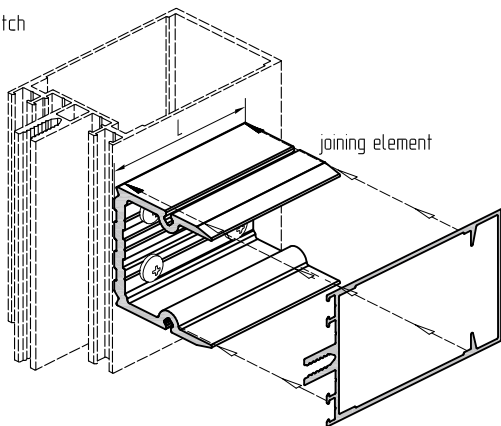

for mullion-transom connection:

- 6 mm notch;
- 6 mm shaped notch

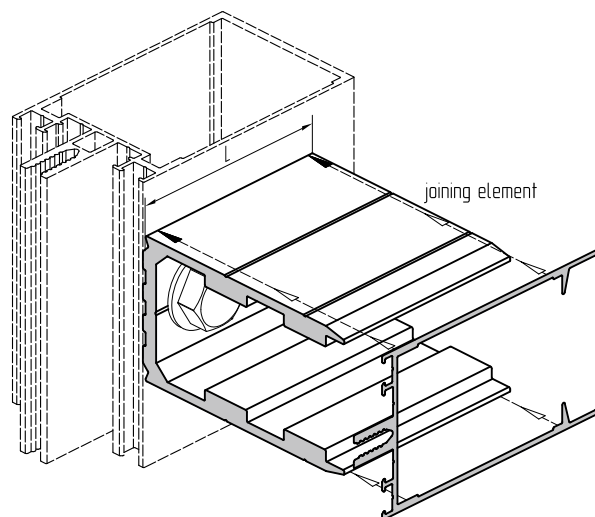

Joining element made of profile AYPF50.0413						Colour	00	Joining element made of profile AYPF50.0407						Colour	00
Code	Article	Length L, mm	for transom	for mullion used as transom	Qty in pack, pcs			Code	Article	Length L, mm	for transom	for mullion used as transom	Qty in pack, pcs		
11235800	AYPC.F50.0966	16	AYPC.F50.0203	-	64			11226500	AYPC.F50.0947	63	AYPC.F50.0206	AYPC.F50.0103	20		
11235900	AYPC.F50.0966-01	36	AYPC.F50.0204	-	80			11224900	AYPC.F50.0947-01	83	AYPC.F50.0207	AYPC.F50.0104	24		
11236000	AYPC.F50.0966-02	45	AYPC.F50.0205 AYPC.F50.0214	AYPC.F50.0102	64			11225000	AYPC.F50.0947-02	102	AYPC.F50.0208	AYPC.F50.0105	18		
11236100	AYPC.F50.0966-03	63	AYPC.F50.0206	AYPC.F50.0103	56			11225100	AYPC.F50.0947-03	122	AYPC.F50.0209	AYPC.F50.0106	24		
11236200	AYPC.F50.0966-04	83	AYPC.F50.0207	AYPC.F50.0104	48			11225200	AYPC.F50.0947-04	152	AYPC.F50.0210	AYPC.F50.0107	20		
11236300	AYPC.F50.0966-05	102	AYPC.F50.0208	AYPC.F50.0105	54			11225300	AYPC.F50.0947-05	181	AYPC.F50.0211	AYPC.F50.0108	16		
11236400	AYPC.F50.0966-06	122	AYPC.F50.0209	AYPC.F50.0106	50										
11236500	AYPC.F50.0966-07	152	AYPC.F50.0210	AYPC.F50.0107	36										
11236600	AYPC.F50.0966-08	181	AYPC.F50.0211	AYPC.F50.0108	34										



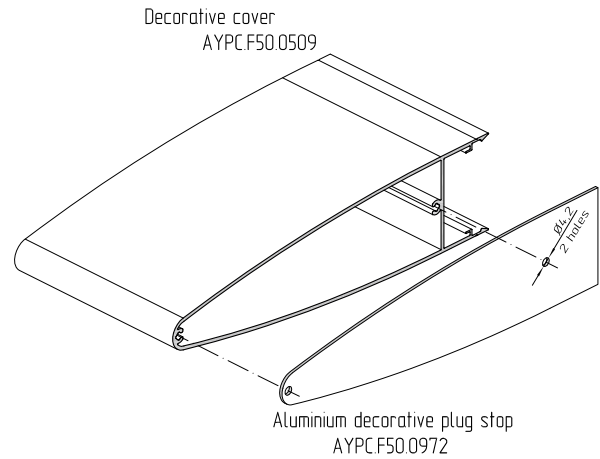
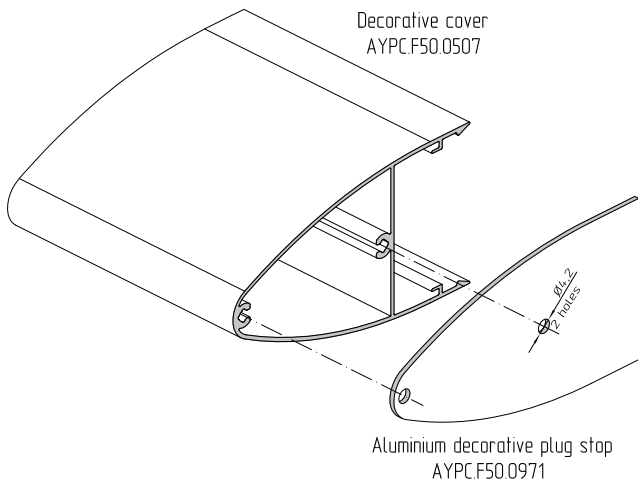

Aluminium decorative plug stop for decorative coverAYPC.F50.0507				Aluminium decorative plug stop for decorative coverAYPC.F50.0509			
Article		AYPC.F50.0971		Article		AYPC.F50.0972	
Dimensions LxH, mm		50x90		Dimensions LxH, mm		50x200	
Packing quantity, pcs.		40		Packing quantity, pcs.		40	
Code	11236831	Colour	RAL9006	Code	11236931	Colour	RAL9006
Code	112368856	Colour	A05-E6	Code	112369856	Colour	A05-E6

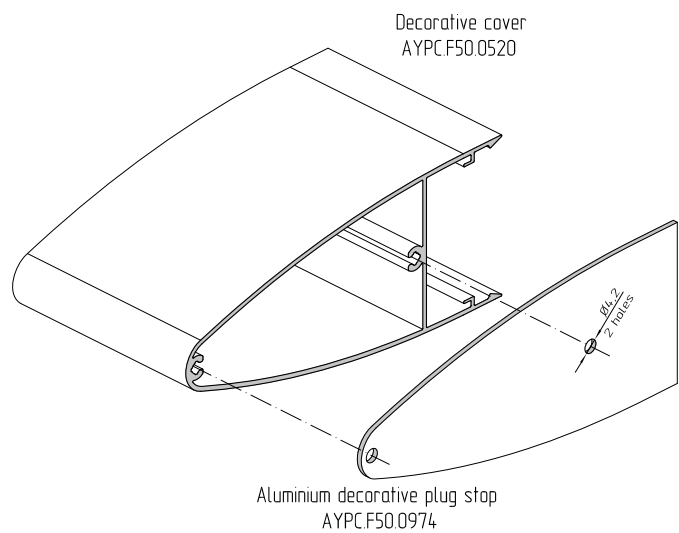
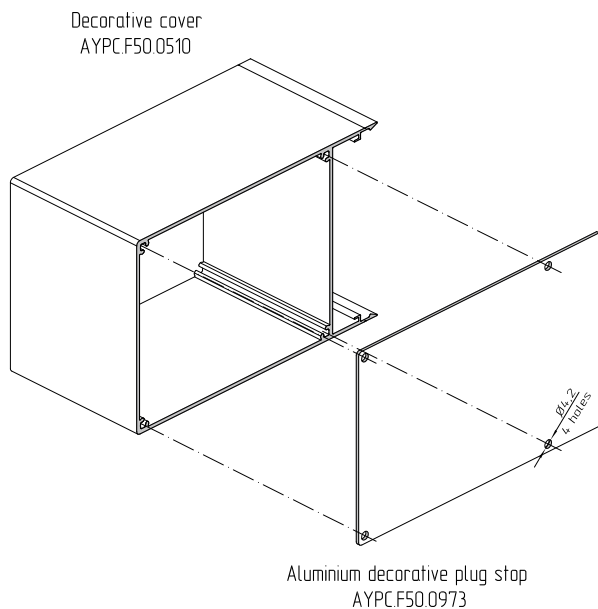

Aluminium decorative plug stop for AYP.C.F50.0510 decorative cover				Aluminium decorative plug stop for AYP.C.F50.0520 decorative cover			
Article		AYPC.F50.0973		Article		AYPC.F50.0974	
Dimensions LxH, mm		100x152		Dimensions LxH, mm		50x120	
Packing quantity, pcs.		30		Packing quantity, pcs.		60	
Code	11237031	Colour	RAL9006	Code	11239431	Colour	RAL9006
Code	112370856	Colour	A05-E6	Code	112394856	Colour	A05-E6

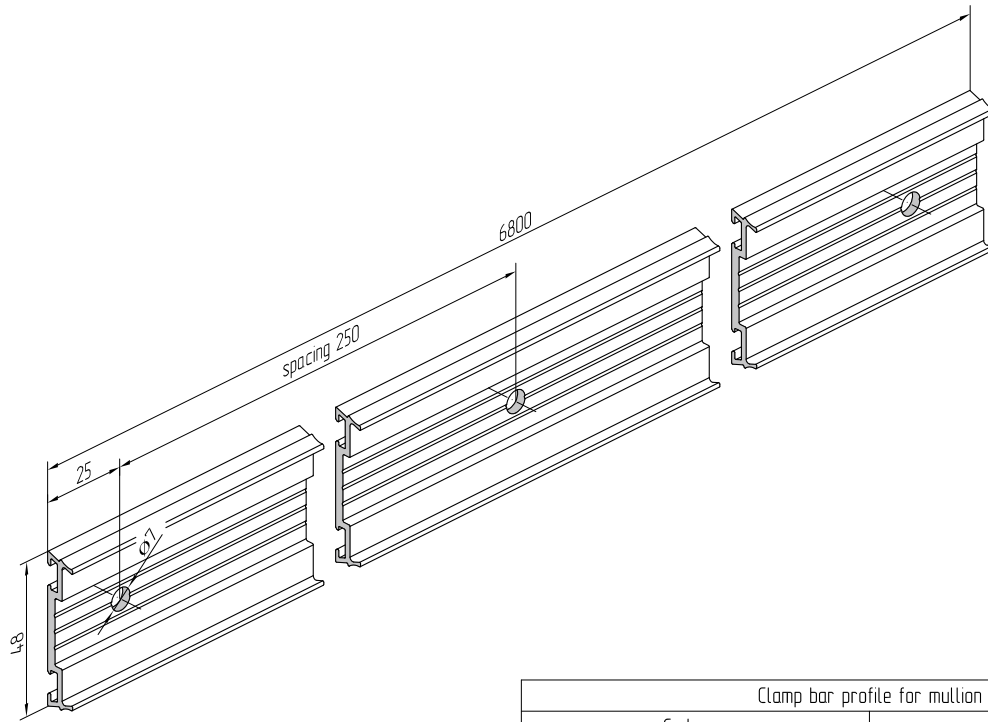

Clamp bar profile for mullion	
Code	11251900
Article	AYPC.F50.0601F
Qty in pack, pcs	10

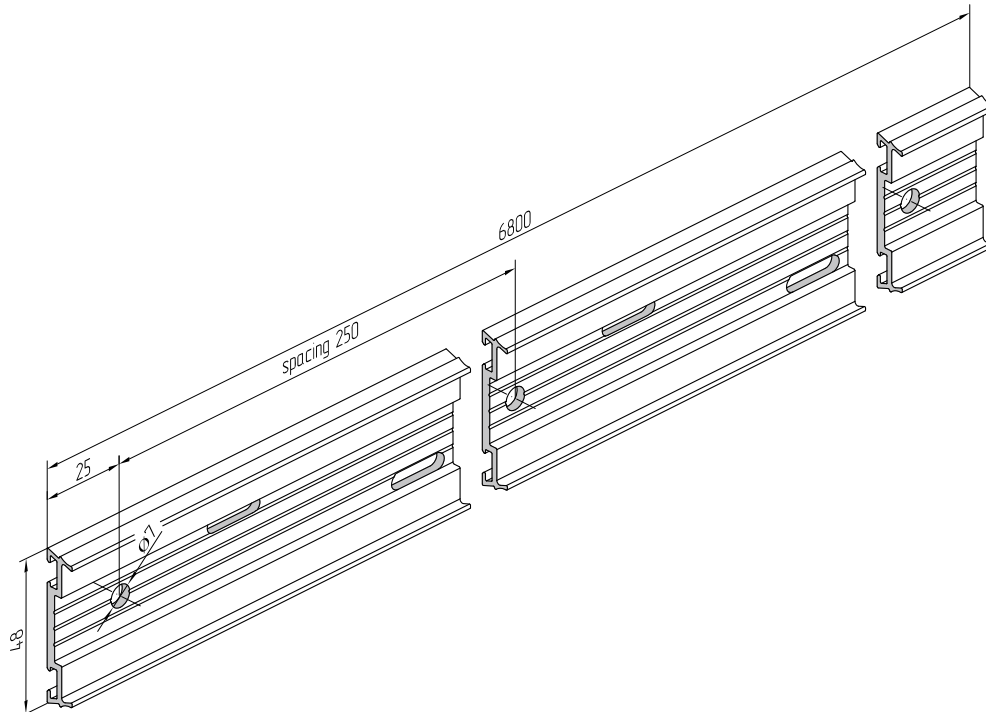

Clamp bar profile for transom	
Code	11252000
Article	AYPC.F50.0601R
Qty in pack, pcs	10

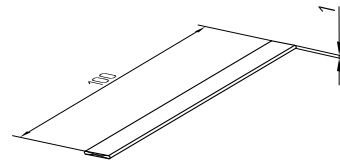
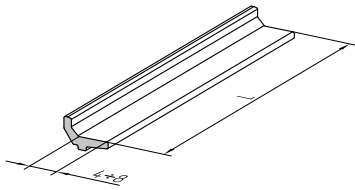

Aluminium support made of AYPF50.0801 profile	
Code	11220700
Article	AYPC.F50.0940
Length L, mm	100
Qty in pack, pcs	150
Colour	00

Leveling plate	
Code	10211200
Article	FRK13
Qty in pack, pcs	300

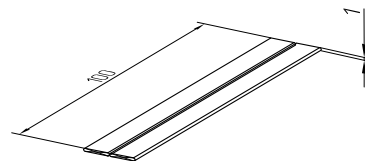
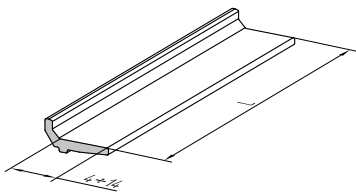

Aluminium support made of AYPF50.0807 profile	
Code	11226600
Article	AYPC.F50.0940-01
Length L, mm	100
Qty in pack, pcs	100
Colour	00

Leveling plate	
Code	10211200
Article	FRK13
Qty in pack, pcs	300

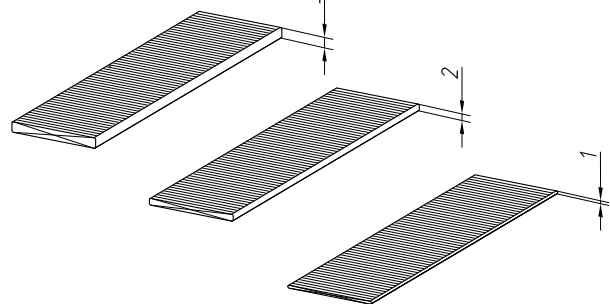
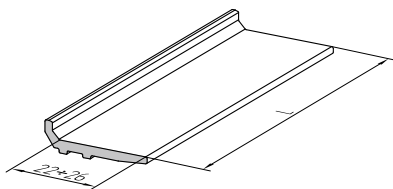

Aluminium support made of AYPF50.0802 profile	
Code	11220800
Article	AYPC.F50.0941
Length L, mm	100
Qty in pack, pcs	100
Colour	00

Leveling plate			
Code	10414600	10414700	10414800
Article	100x26x1	100x26x2	100x26x3
Qty in pack, pcs	1000	1000	1000

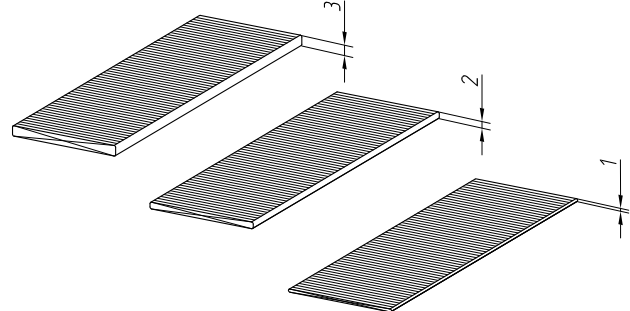
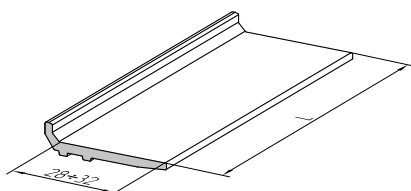

Aluminium support made of AYPF50.0803 profile	
Code	11220900
Article	AYPC.F50.0941-01
Length L, mm	100
Qty in pack, pcs	100
Colour	00

Leveling plate			
Code	11213400	11213500	11213600
Article	100x32x1	100x32x2	100x32x3
Qty in pack, pcs	1000	1000	1000

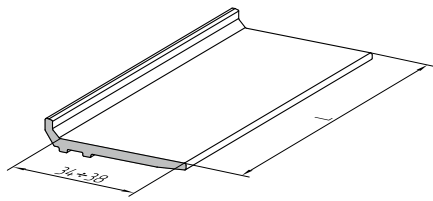

Aluminium support made of AYPC.F50.0804 profile	
Code	11221000
Article	AYPC.F50.0941-02
Length L, mm	100
Qty in pack, pcs	70
Colour	00

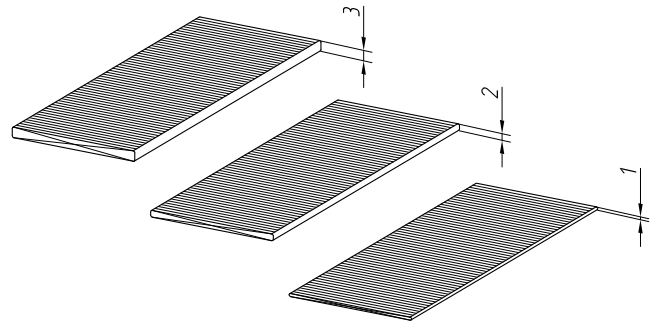

Leveling plate			
Code	11213700	11213800	11213900
Article	100x38x1	100x38x2	100x38x3
Qty in pack, pcs	1000	1000	1000

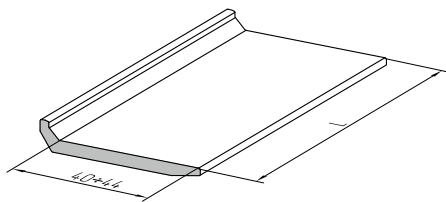

Aluminium support made of AYPC.F50.0805 profile	
Code	11230700
Article	AYPC.F50.0952
Length L, mm	100
Qty in pack, pcs	50
Colour	00

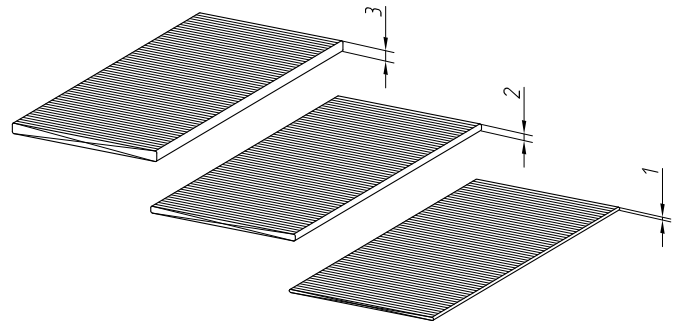

Leveling plate			
Code	11218100	11218200	11218300
Article	100x44x1	100x44x2	100x44x3
Qty in pack, pcs	1000	1000	1000

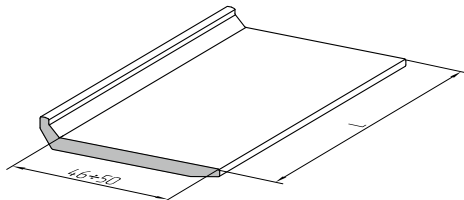

Aluminium support made of AYPC.F50.0806 profile	
Code	11230800
Article	AYPC.F50.0952-01
Length L, mm	100
Qty in pack, pcs	50
Colour	00

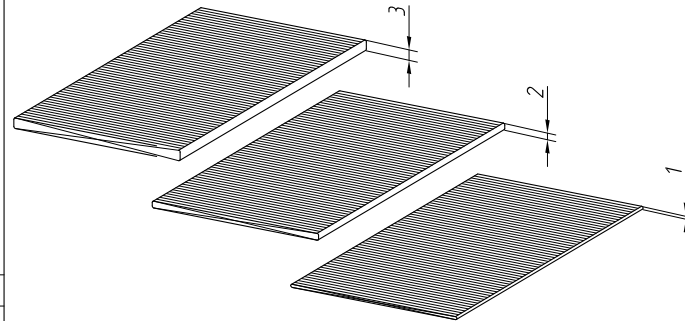

Leveling plate			
Code	11218400	11218500	11218600
Article	100x50x1	100x50x2	100x50x3
Qty in pack, pcs	1000	1000	1000

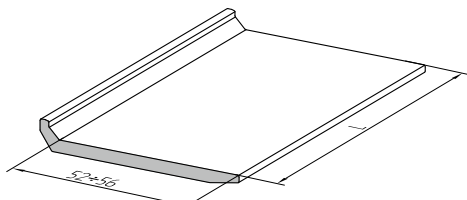

Aluminium support made of AYPC.F50.0814 profile	
Code	11231800
Article	AYPC.F50.0952-02
Length L, mm	100
Qty in pack, pcs	50
Colour	00

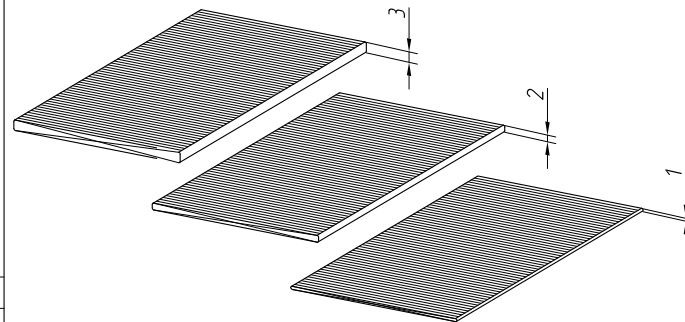

Leveling plate			
Code	11219100	11219200	11219300
Article	100x56x1	100x56x2	100x56x3
Qty in pack, pcs	1000	1000	1000

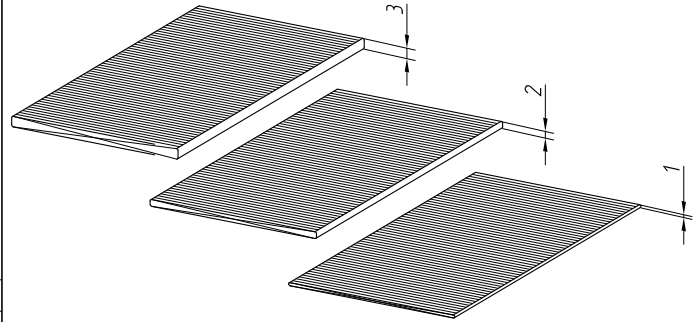
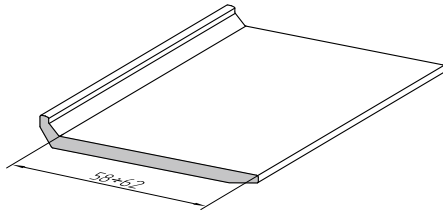

Aluminium support made of AYPF50.0815 profile	
Code	11236700
Article	AYPC.F50.0952-03
Length L, mm	100
Qty in pack, pcs	50
Colour	00

Leveling plate			
Code	11219400	11219500	11219600
Article	100x62x1	100x62x2	100x62x3
Qty in pack, pcs	1000	1000	1000

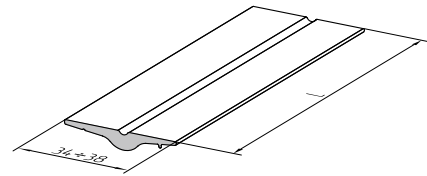
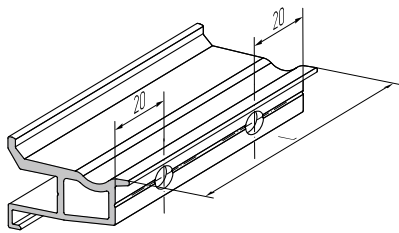

Aluminium support made of AYPF50.0808 profile	
Code	11225400
Article	AYPC.F50.0948
Length L, mm	100
Qty in pack, pcs	50
Colour	00

Aluminium support made of AYPF50.0811 profile	
Code	11225500
Article	AYPC.F50.0949
Length L, mm	100
Qty in pack, pcs	50
Colour	00

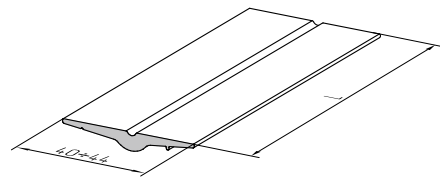
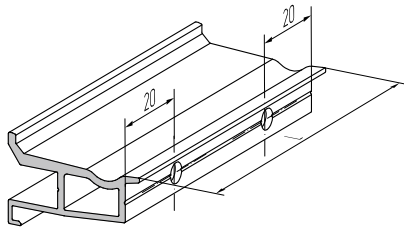

Aluminium support made of AYPF50.0809 profile	
Code	11227000
Article	AYPC.F50.0948-01
Length L, mm	100
Qty in pack, pcs	50
Colour	00

Aluminium support made of AYPF50.0812 profile	
Code	11227200
Article	AYPC.F50.0949-01
Length L, mm	100
Qty in pack, pcs	50
Colour	00

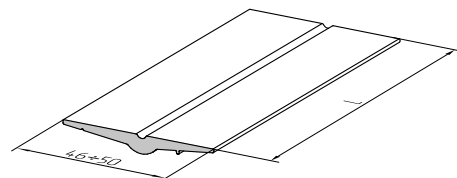
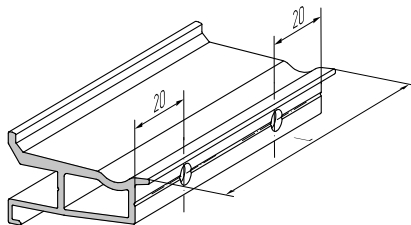

Aluminium support made of AYPF50.0810 profile	
Code	11227100
Article	AYPC.F50.0948-02
Length L, mm	100
Qty in pack, pcs	50
Colour	00

Aluminium support made of AYPF50.0813 profile	
Code	11227300
Article	AYPC.F50.0949-02
Length L, mm	100
Qty in pack, pcs	50
Colour	00

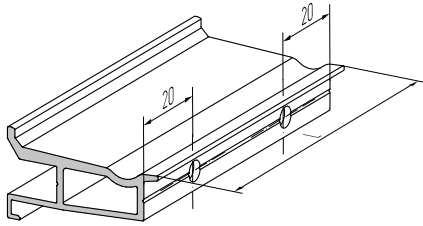

Aluminium support made of AYPF.F50.0816 profile	
Code	11230900
Article	AYPC.F50.0948-03
Length L, mm	100
Qty in pack, pcs	50
Colour	00

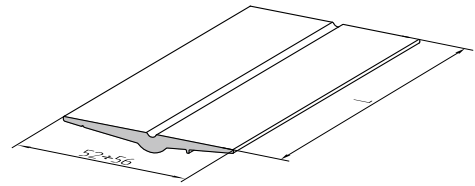

Aluminium support made of AYPF.F50.0817 profile	
Code	11231000
Article	AYPC.F50.0949-03
Length L, mm	100
Qty in pack, pcs	50
Colour	00

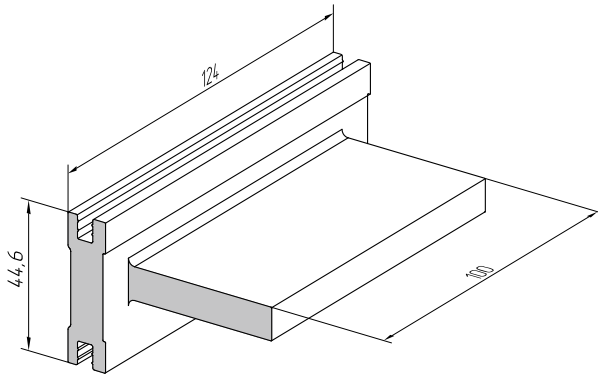

Aluminium support made of AYPF.F50.0818 profile	
Code	11235700
Article	AYPC.F50.0953
Length L, mm	124
Qty in pack, pcs	50
Colour	00

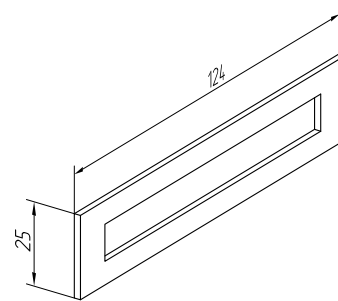

The sealing washer AYPF.F50.0930	
Code	11219700
Article	AYPC.F50.0930
Length L, mm	124
Qty in pack, pcs	100
Colour	Black

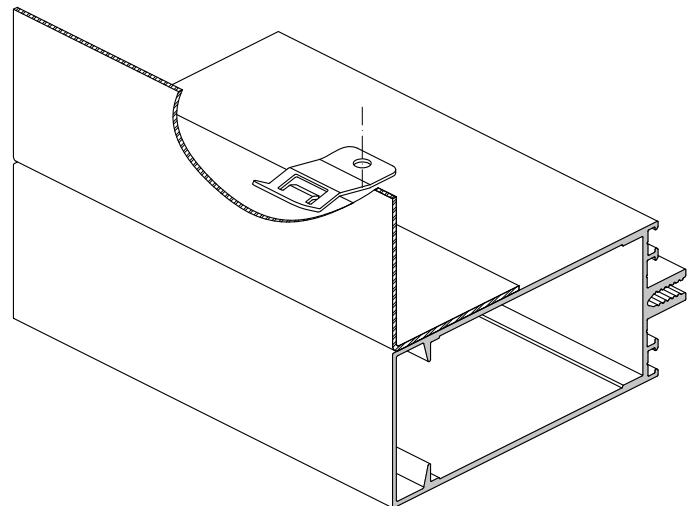
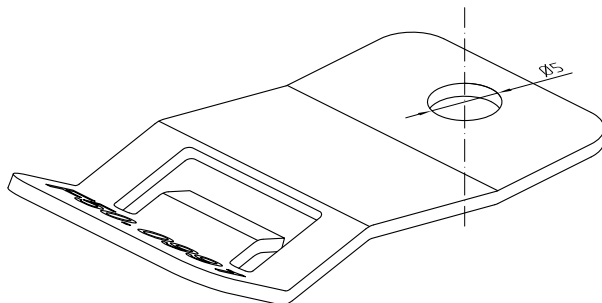

Clip	
Code	11327200
Article	AYPC.F50.0991
Length L, mm	124
Qty in pack, pcs	50
Colour	Stainless steel

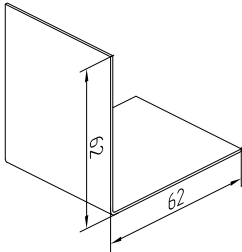
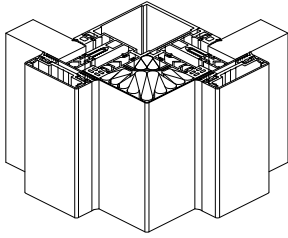
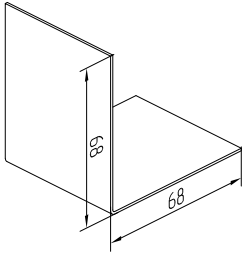
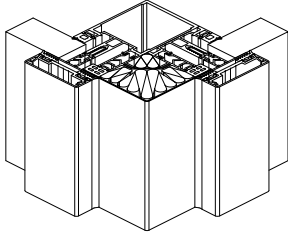
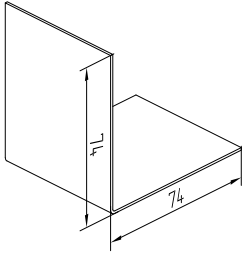
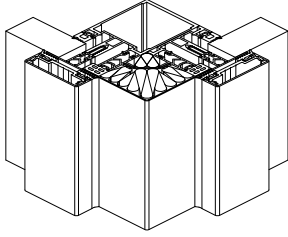
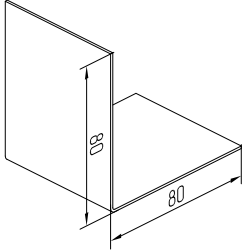
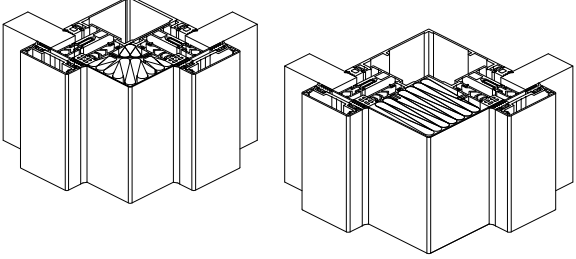
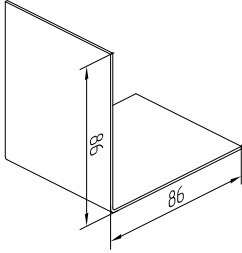
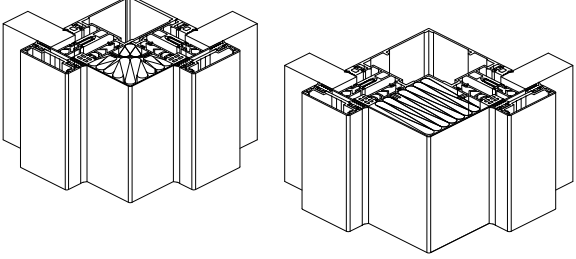
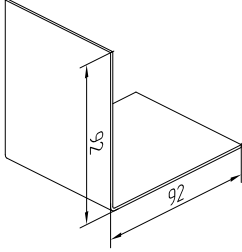
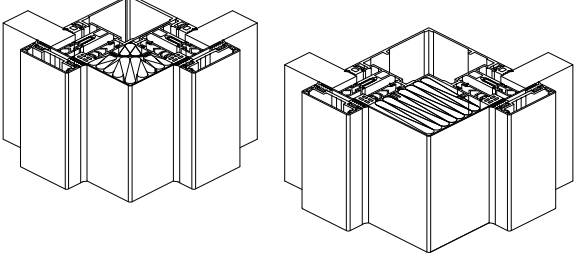
Drawing	Code	Color	Article	Application
 <p>Packing quantity - 4 pcs in 6,0m.</p>	11239500 11239521 11239524 11239530 11239531	00 RAL9016 RAL8014 RAL8017 RAL9006	AYPC.F50.0992	
 <p>Packing quantity - 4 pcs in 6,0m.</p>	11239600 11239621 11239624 11239630 11239631	00 RAL9016 RAL8014 RAL8017 RAL9006	AYPC.F50.0992-01	
 <p>Packing quantity - 4 pcs in 6,0m.</p>	11239700 11239721 11239724 11239730 11239731	00 RAL9016 RAL8014 RAL8017 RAL9006	AYPC.F50.0992-02	
 <p>Packing quantity - 4 pcs in 6,0m.</p>	11239800 11239821 11239824 11239830 11239831	00 RAL9016 RAL8014 RAL8017 RAL9006	AYPC.F50.0992-03	
 <p>Packing quantity - 4 pcs in 6,0m.</p>	11239900 11239921 11239924 11239930 11239931	00 RAL9016 RAL8014 RAL8017 RAL9006	AYPC.F50.0992-04	
 <p>Packing quantity - 4 pcs in 6,0m.</p>	11240000 11240021 11240024 11240030 11240031	00 RAL9016 RAL8014 RAL8017 RAL9006	AYPC.F50.0992-05	

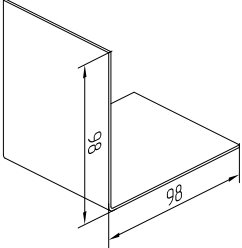
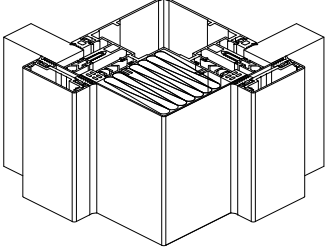
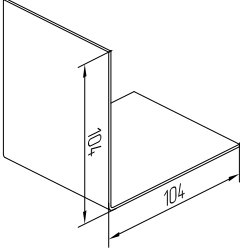
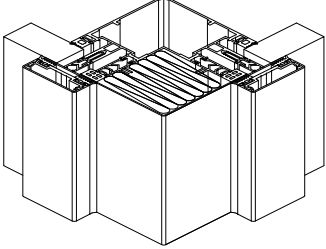
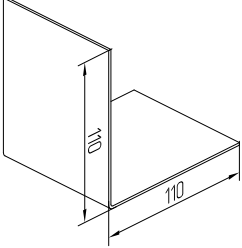
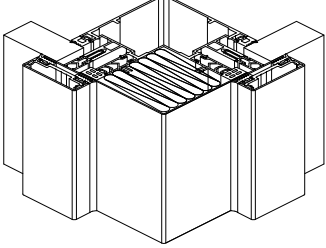
Drawing	Code	Color	Article	Application
	1124-0100 1124-0121 1124-0124 1124-0130 1124-0131	00 RAL9016 RAL8014 RAL8017 RAL9006	AYPC.F50.0992-06	
Packing quantity - 4 pcs in 6,0m.				
	1124-0200 1124-0221 1124-0224 1124-0230 1124-0231	00 RAL9016 RAL8014 RAL8017 RAL9006	AYPC.F50.0992-07	
Packing quantity - 4 pcs in 6,0m.				
	1124-0300 1124-0321 1124-0324 1124-0330 1124-0331	00 RAL9016 RAL8014 RAL8017 RAL9006	AYPC.F50.0992-08	
Packing quantity - 4 pcs in 6,0m.				



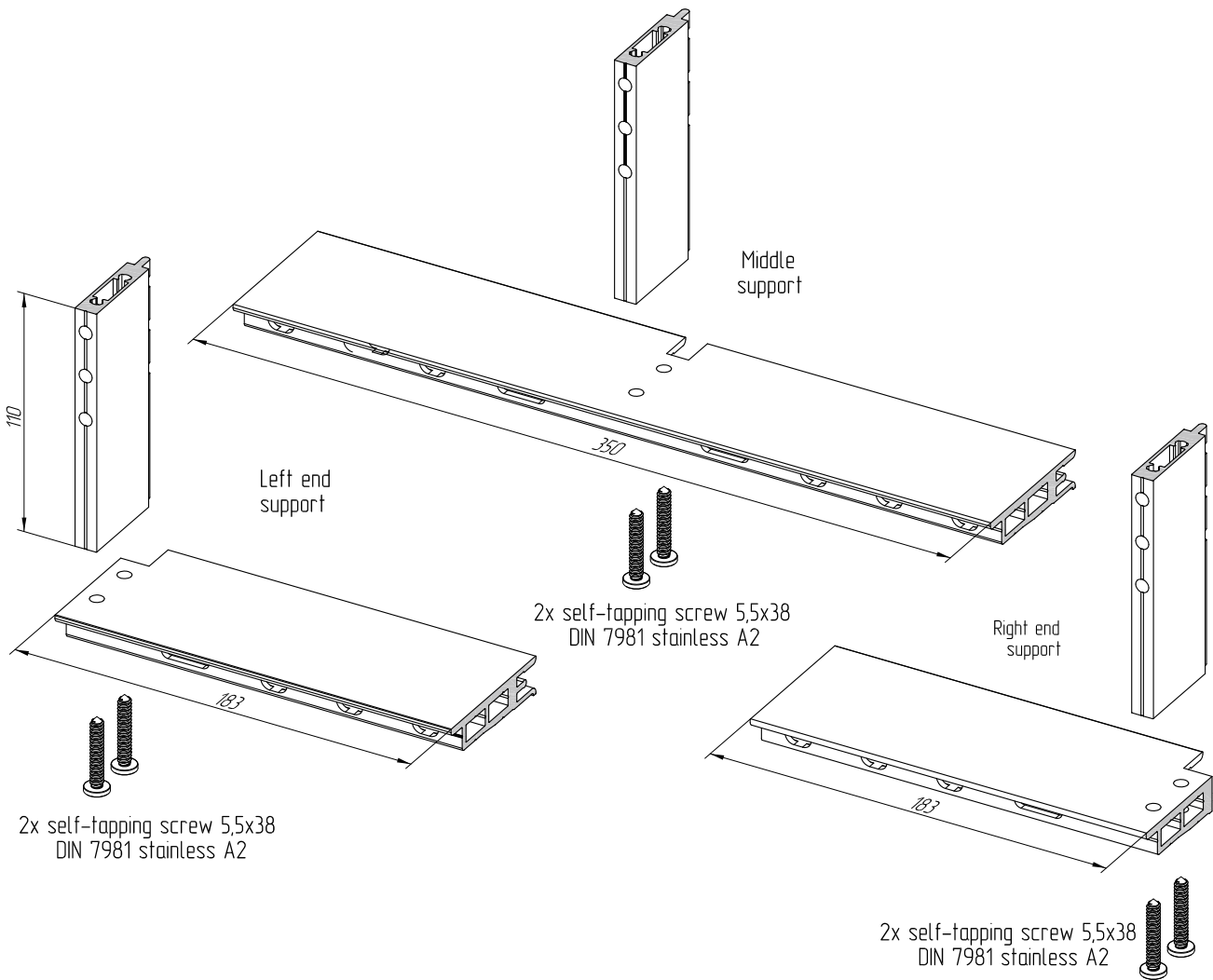







Aluminium bearing support						
Glass thickness, mm	Article of left end support kit	Article of middle support kit	Article of right end support kit	Code	Packing quantity, pcs.	Color
34-38	-	AYPC.F50.0965	-	11234200	14	00
34-38	-	-	AYPC.F50.0965-01	11234300	6	00
34-38	AYPC.F50.0965-02	-	-	11234400	6	00
40-44	-	AYPC.F50.0965-03	-	11234500	12	00
40-44	-	-	AYPC.F50.0965-04	11234600	6	00
40-44	AYPC.F50.0965-05	-	-	11234700	6	00
46-50	-	AYPC.F50.0965-06	-	11234800	12	00
46-50	-	-	AYPC.F50.0965-07	11234900	6	00
46-50	AYPC.F50.0965-08	-	-	11235000	6	00
52-56	-	AYPC.F50.0965-09	-	11235100	10	00
52-56	-	-	AYPC.F50.0965-10	11235200	4	00
52-56	AYPC.F50.0965-11	-	-	11235300	4	00
58-62	-	AYPC.F50.0965-12	-	11235400	10	00
58-62	-	-	AYPC.F50.0965-13	11235500	4	00
58-62	AYPC.F50.0965-14	-	-	11235600	4	00



Kits are unassembled  
Max. twisting couple of self-tapping for parts connecting is 7 H\*m

Max. weight of glazing depending on bearing support and type of mullion and transom connection

Joint elements	Glazing thickness, mm	Standard support		Swinging support		Shaped notch connection of mullion and transom		Cross-shaped supports middle		Cross-shaped supports right and left		Insert element - standard support / plate made from stainless steel A2	
		Article	kN	Article	kN	Article	kN	Article	kN	Article	kN	Article	kN
 2x self-tapping screw 3.9x16 DIN7981 TX    AYPFC50.0403 + AYPFC50.0940 • 2x self-tapping screw 3.9x13 DIN 7982 AYPFC50.0402 + AYPFC50.0940 • 2x self-tapping screw 3.9x13 DIN 7982	4-8	AYPFC50.0940	1.00	-	-	-	-	-	-	-	-	-	-
	22-26	AYPFC50.0941	1.00	-	-	-	-	-	-	-	-	-	-
	28-32	AYPFC50.0941-01	1.00	-	-	-	-	-	-	-	-	-	-
	4-8	AYPFC50.0940	1.80	-	-	-	-	-	-	-	-	-	-
	22-26	AYPFC50.0941	1.80	-	-	-	-	-	-	-	-	-	-
	28-32	AYPFC50.0941-01	1.80	-	-	-	-	-	-	-	-	-	-
	34-38	AYPFC50.0941-02	1.80	-	-	-	-	-	-	-	-	-	-
	40-44	AYPFC50.0952	1.60	-	-	-	-	-	-	-	-	-	-
	46-50	AYPFC50.0952-01	1.60	-	-	-	-	-	-	-	-	-	-
	52-56	AYPFC50.0952-02	1.60	-	-	-	-	-	-	-	-	-	-
	58-62	AYPFC50.0952-03	1.60	-	-	-	-	-	-	-	-	-	-
	   AYPFC50.0403 + AYPFC50.0945 AYPFC50.0410 AYPFC50.0412 AYPFC50.0413 AYPFC50.0414 • 4x self-tapping screw 3.9x13 DIN 7981 **AYPFC50.0414 • 2x BOLT M10x70 DIN 931 BUSH F50.0950, NUT M10 DIN 934	4-8	AYPFC50.0940	1.80	-	-	-	-	-	-	-	-	-
22-26		AYPFC50.0941	1.80	-	-	-	-	-	-	-	-	-	-
28-32		AYPFC50.0941-01	1.80	-	-	-	-	-	-	-	-	-	-
34-38		AYPFC50.0941-02	1.80	-	-	-	-	-	-	-	-	-	-
40-44		AYPFC50.0941-02	1.80	2.80/3.20**	AYPFC50.0948 + AYPFC50.0949	3.20	AYPFC50.0948 + AYPFC50.0949	-	-	-	-	-	-
46-50		AYPFC50.0952-01	1.80	2.50/2.90**	AYPFC50.0948-01 + AYPFC50.0949-01	2.90	AYPFC50.0948-01 + AYPFC50.0949-01	-	-	-	-	-	-
52-56		AYPFC50.0952-02	1.80	2.40/2.80**	AYPFC50.0948-02 + AYPFC50.0949-02	2.70	AYPFC50.0948-02 + AYPFC50.0949-02	-	-	-	-	-	-
58-62		AYPFC50.0952-03	1.80	2.20/2.60**	AYPFC50.0948-03 + AYPFC50.0949-03	2.40	AYPFC50.0948-03 + AYPFC50.0949-03	-	-	-	-	-	-
34-38		-	-	4.30	AYPFC50.0948 + AYPFC50.0949	4.30	AYPFC50.0948 + AYPFC50.0949	7.00	AYPFC50.0945	AYPFC50.0965-01, AYPFC50.0965-02	4.70	AYPFC50.0953*	6.00
40-44		-	-	4.0	AYPFC50.0948-01 + AYPFC50.0949-01	4.0	AYPFC50.0948-01 + AYPFC50.0949-01	7.00	AYPFC50.0965-03	AYPFC50.0965-04, AYPFC50.0965-05	4.60	AYPFC50.0953 + AYPFC50.0952	5.30
46-50		-	-	3.70	AYPFC50.0948-02 + AYPFC50.0949-02	3.70	AYPFC50.0948-02 + AYPFC50.0949-02	6.80	AYPFC50.0965-06	AYPFC50.0965-07, AYPFC50.0965-08	4.50	AYPFC50.0953 + F50.0952-01/100x52x4	4.80
52-56		-	-	3.40	AYPFC50.0948-03 + AYPFC50.0949-03	3.40	AYPFC50.0948-03 + AYPFC50.0949-03	6.60	AYPFC50.0965-09	AYPFC50.0965-10, AYPFC50.0965-11	4.40	AYPFC50.0953 + F50.0952-02/100x58x4	3.30/4.30
58-62	-	-	-	-	-	-	6.40	AYPFC50.0965-12	AYPFC50.0965-13, AYPFC50.0965-14	4.30	AYPFC50.0953 + F50.0952-03/100x64x4	3.00/3.90	

\* F50.0953 bearing support (glass thickness 34-38 mm, notch connection) should be applied with the kit of PVC supports of 6 mm total width

\*\* The load is correct when the joining element is fixed to the mullion with M10x90 bolt

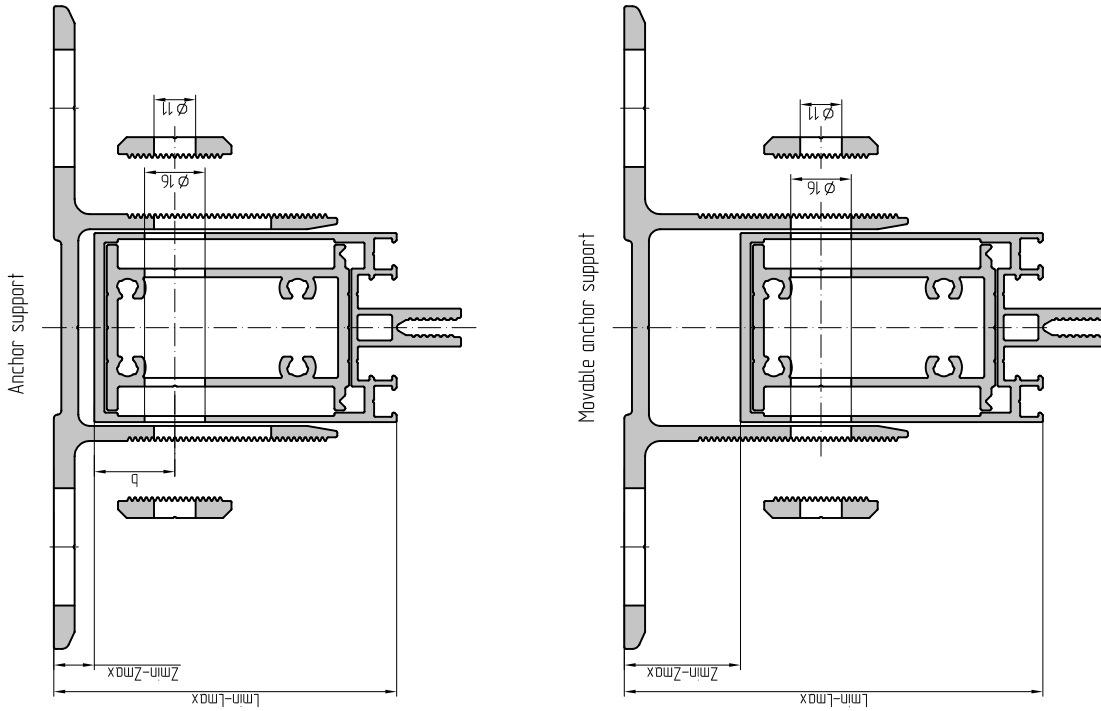

Table of support selection

Table 1	Mullion	Mullion height, mm	b-to the hole axle, mm	Anchor support	L		Z-Space between wall and facade		Adjustment	Movable anchor support
					min	max	min	max		
AYPC F50.0102	62	213		AYPC F50.2901	75	90	13	28	15	AYPC F50.2902
				AYPC F50.2901-01	100	115	38	53	15	AYPC F50.2902-01
				AYPC F50.2901-02	140	155	78	93	15	AYPC F50.2902-02
				AYPC F50.2901-03	180	195	118	133	15	AYPC F50.2902-03
AYPC F50.0103	80	213		AYPC F50.2901	90	110	10	30	20	AYPC F50.2902
				AYPC F50.2901-01	100	135	20	55	35	AYPC F50.2902-01
				AYPC F50.2901-02	140	175	60	95	35	AYPC F50.2902-02
				AYPC F50.2901-03	180	215	100	135	35	AYPC F50.2902-03
AYPC F50.0104	100	22		AYPC F50.2901	110	130	10	30	20	AYPC F50.2902
				AYPC F50.2901-01	110	155	10	55	45	AYPC F50.2902-01
				AYPC F50.2901-02	145	195	45	95	50	AYPC F50.2902-02
				AYPC F50.2901-03	135	185	35	85	50	AYPC F50.2902-03
AYPC F50.0105	120	27		AYPC F50.2901	110	125	10	25	15	AYPC F50.2902
				AYPC F50.2901-01	110	150	10	50	40	AYPC F50.2902-01
				AYPC F50.2901-02	140	190	40	90	50	AYPC F50.2902-02
				AYPC F50.2901-03	180	230	80	130	50	AYPC F50.2902-03
AYPC F50.0106	140	47		AYPC F50.2901-01	130	150	10	30	20	AYPC F50.2902-01
				AYPC F50.2901-02	140	190	20	70	50	AYPC F50.2902-02
				AYPC F50.2901-03	180	230	60	110	50	AYPC F50.2902-03
				AYPC F50.2901-01	150	160	10	20	10	AYPC F50.2902-01
AYPC F50.0107	170	57		AYPC F50.2901-02	150	200	10	60	50	AYPC F50.2902-02
				AYPC F50.2901-03	190	240	50	100	50	AYPC F50.2902-03
				AYPC F50.2901-02	150	190	10	50	40	AYPC F50.2902-02
				AYPC F50.2901-03	180	230	40	90	50	AYPC F50.2902-03
AYPC F50.0108	200	67		AYPC F50.2901-01	180	190	10	20	10	AYPC F50.2902-01
				AYPC F50.2901-02	180	230	10	60	50	AYPC F50.2902-02
				AYPC F50.2901-01	210	220	10	20	10	AYPC F50.2902-01
				AYPC F50.2901-02	210	260	10	60	50	AYPC F50.2902-02
AYPC F50.0108	200	67		AYPC F50.2901-03	250	300	50	100	50	AYPC F50.2902-03
				AYPC F50.2901-02	210	220	70	80	10	AYPC F50.2902-02
				AYPC F50.2901-03	210	260	70	120	50	AYPC F50.2902-03
				AYPC F50.2901-02	210	260	70	120	50	AYPC F50.2902-02

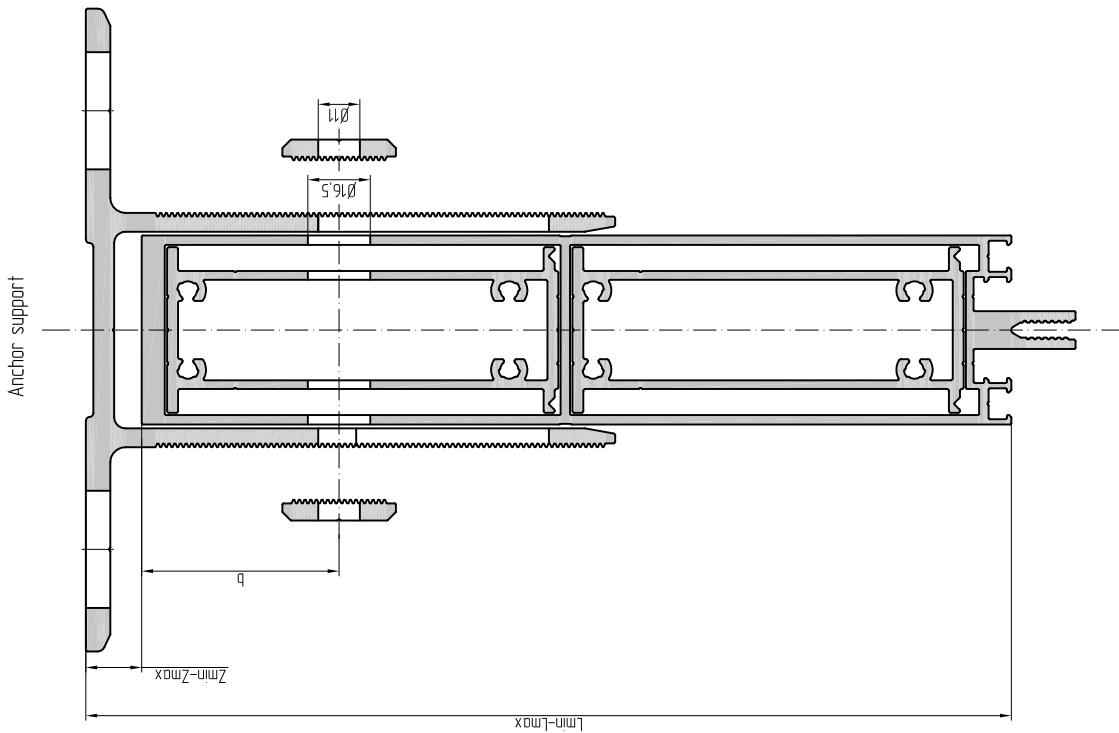
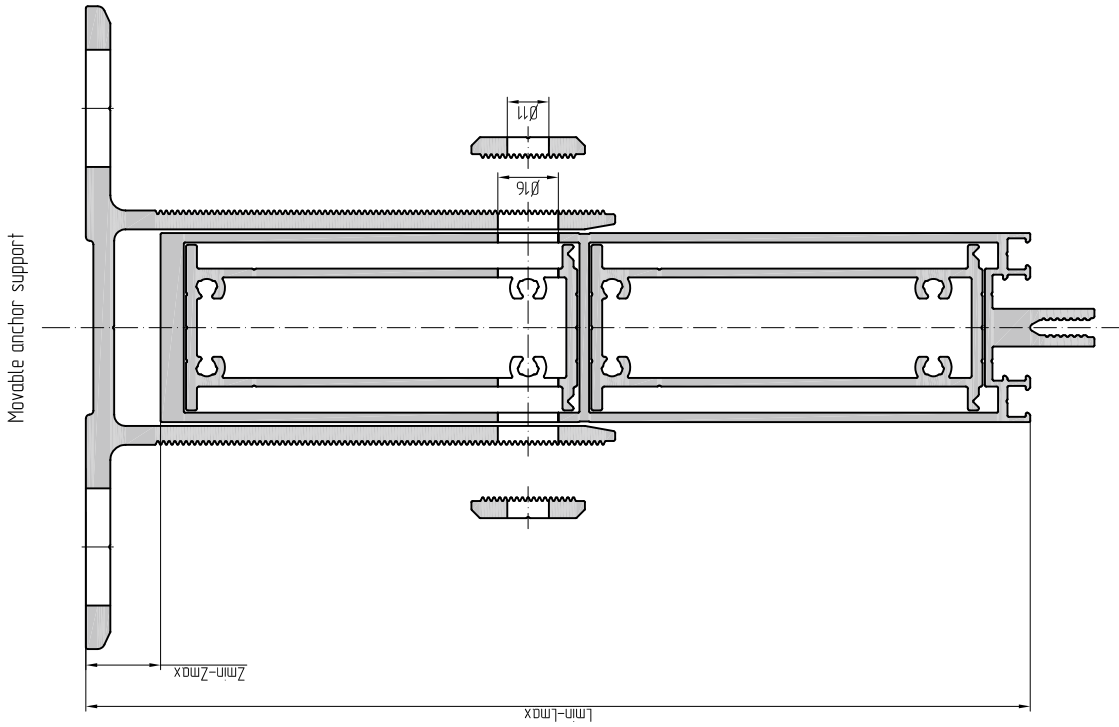
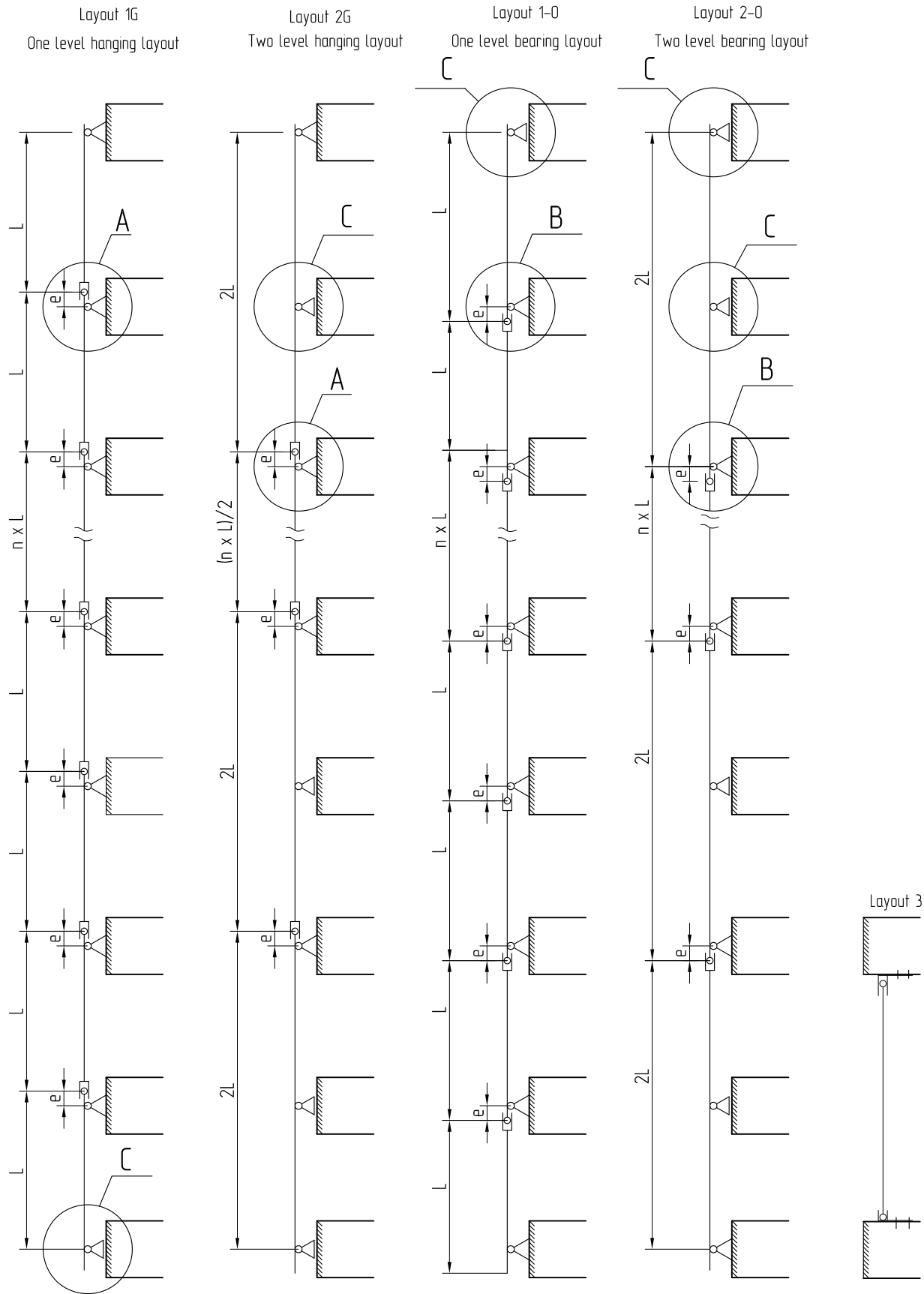

Table of support selection

Table 2	Mullion	Mullion height, mm	b-to the hole axle, mm	Anchor support	L		Z-space between wall and facade		Adjustment	Movable anchor support
					min	max	min	max		
	AYPC.F50.0110	230	47	AYPC.F50.2901-02	250	300	20	70	50	AYPC.F50.2902-02
	AYPC.F50.0111	270	67	AYPC.F50.2901-03	310	360	40	90	50	AYPC.F50.2902-03

Main layouts of curtain wall system fixation.



Offset value isn't accepted as minimal allowable, that permits to accept the rated layout 1G as a single span beam freely supported, but a layout 2G - as a double span. Guideline for layouts 1G and 2G - curve with stretching. (Hanging layout) as well for layouts 1-0 and 2-0 - curve with shrinking (Bearing layout). Layout 3 is used for building facade into opening. Bearing layouts 1G and 2G are the most applicable, where guidelines work in bending with tension. (Layout 1G is used under heavy glassing).

### Junction A Anchor (bearing) matched fastening with bottom fixation. (Hanging layout)

Bottom guideline – stationary fastening regarding to brackets, upper guideline – vertically flexible articulated fastening

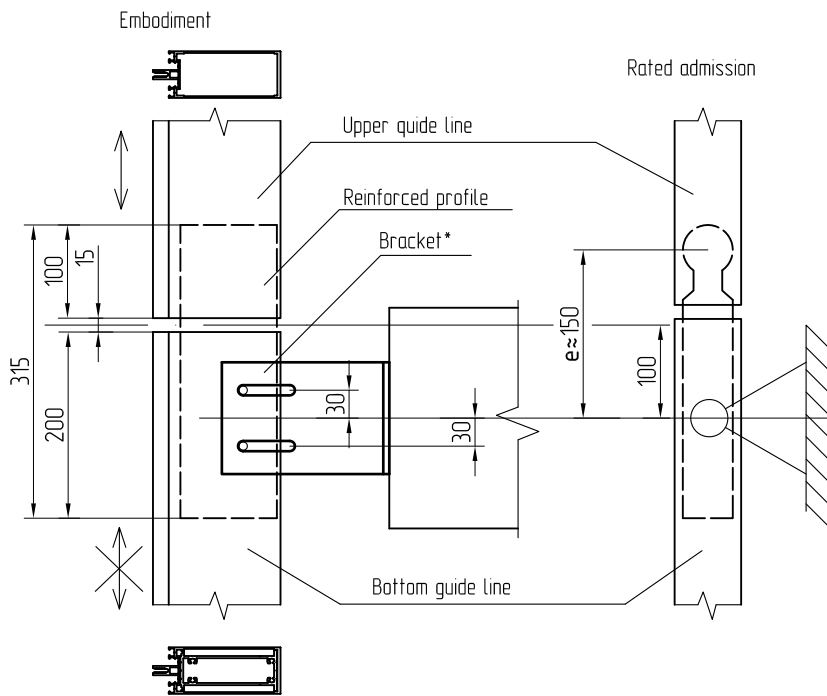

Justification for admission of guideline articulated junction with short insert part of reinforced profile:

Max. ratio of deflection for profiles is standardised  $\frac{1}{300}$ , installing glass units. It permits to identify section return angle on the support.

Return angle of support section in radians:

$$\Theta = \frac{q^n L^3}{24 EI}$$

Guide rail ratio of deflection:

$$\frac{f^{\max}}{L} = \frac{5q^n L^3}{384 EI} \leq \frac{1}{300}$$

from this it follows that

$$\frac{q^n L^3}{EI} \leq \frac{384}{300 * 5}$$

hence

$$\Theta = \frac{q^n L^3}{24 EI} \leq \frac{384}{24 * 300 * 5} \leq 0,011 \text{ (rad)}$$

Rated gap between profile and reinforcing element is 1,2 mm. When reinforcing element goes inside the profile to 100 mm the ratio is 1,2/100, from this it follows that it is 0,012, and therefore this connection allows section turn to 0,012 radian without jam (if there is a small angle, slope ratio is the angle in radians).

\* The following supports are used as a bracket:

AYPC.F50.2901; AYPC.F50.2901-01;  
AYPC.F50.2901-03; AYPC.F50.2901-02  
sheets 03.11 ... 03.14

### Junction B Anchor (bearing) matched fastening with upper fixation. (Bearing layout)

Upper bottom – stationary fastening from the side of a bracket, bottom guide line – vertically flexible articulated fastening

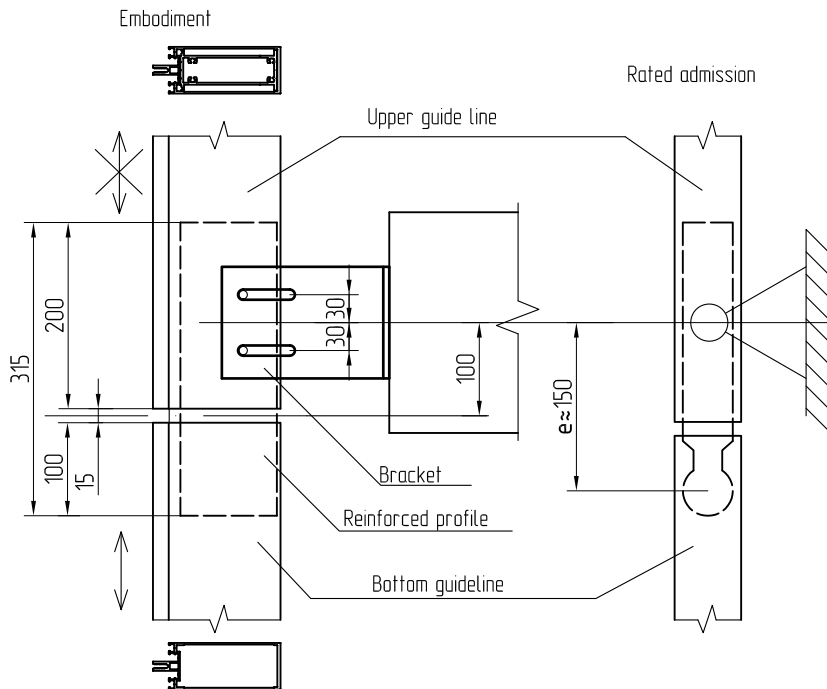

### Junction C

Vertical hinge mount

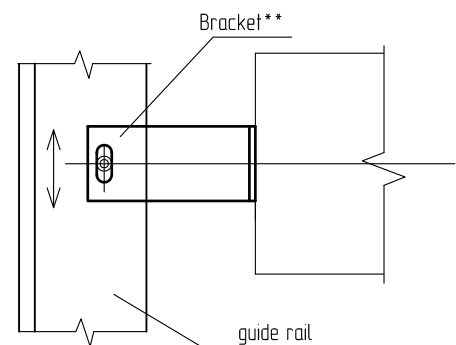

\*\* The following supports are used as a bracket:

AYPC.F50.2902; AYPC.F50.2902-01; AYPC.F50.2902-02;  
AYPC.F50.2902-03  
sheets 03.15 ... 03.18

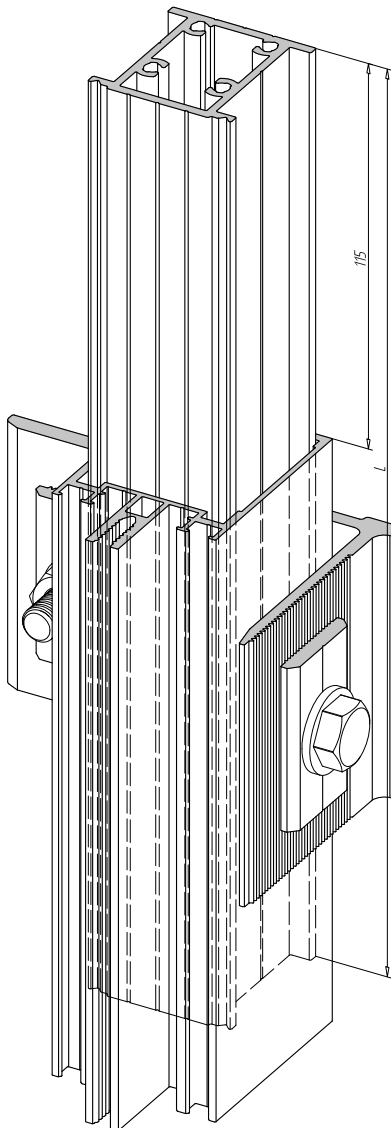
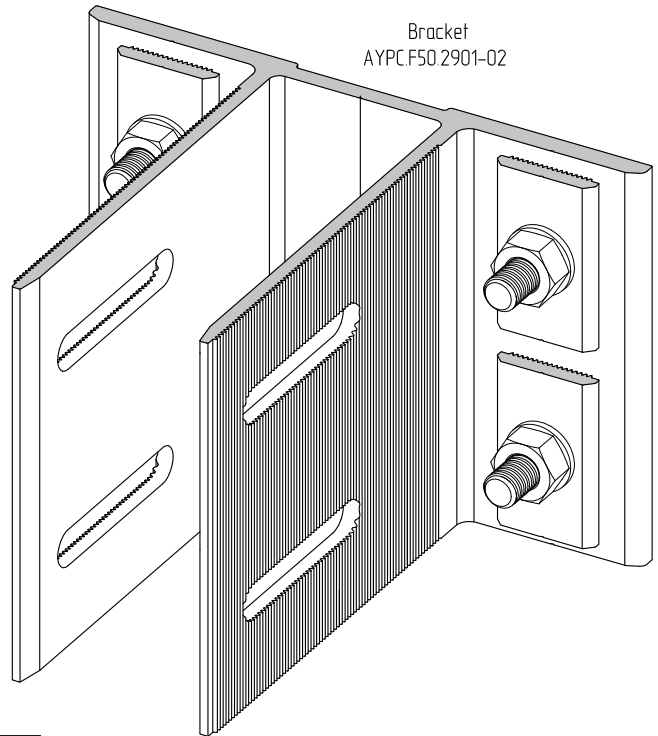
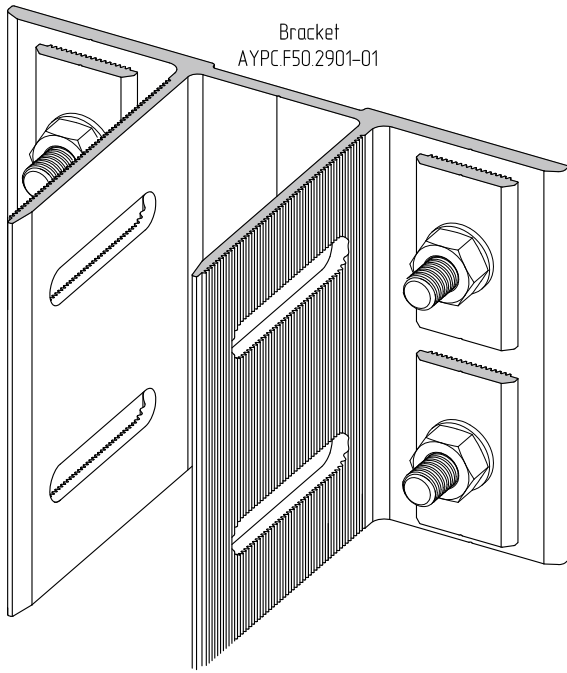

Joining element	
Article	Length L, mm
AYPC.F50.0302	315
AYPC.F50.0303	315
AYPC.F50.0304	315
AYPC.F50.0305	315
AYPC.F50.0306	315
AYPC.F50.0307	315
AYPC.F50.0308	315

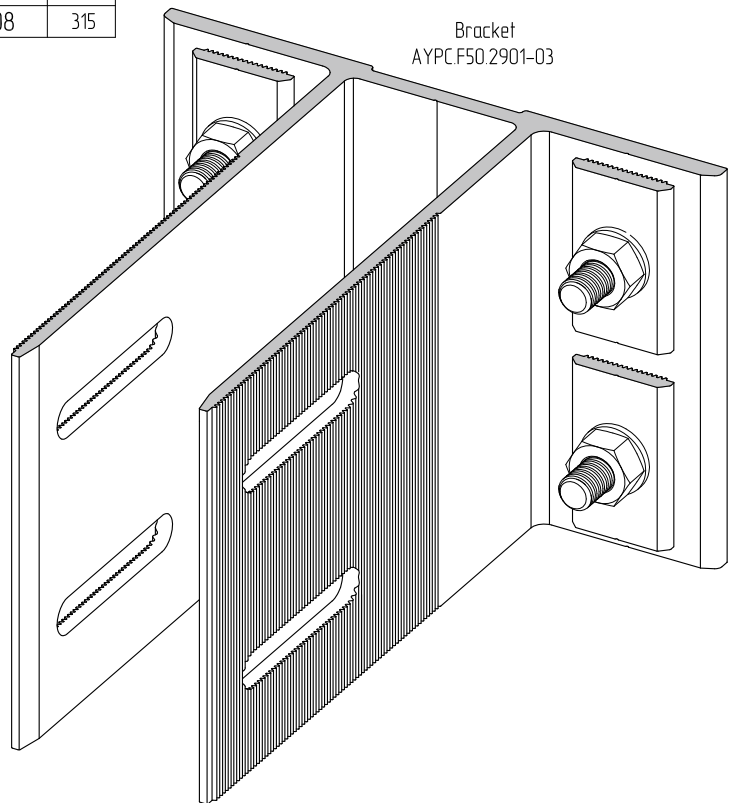
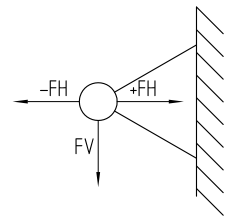

Support installation for top hung fastening

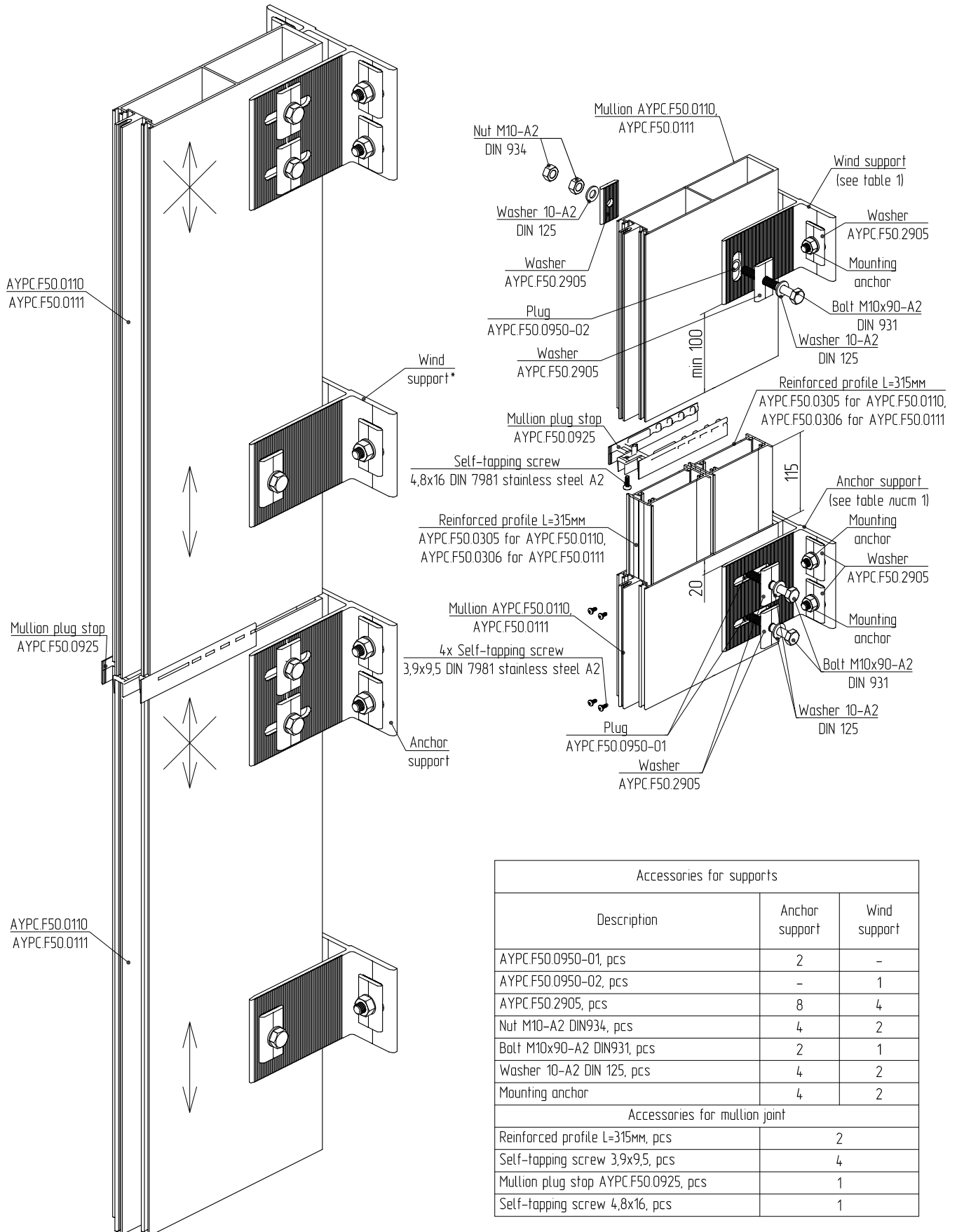

Accessories for supports		
Description	Anchor support	Wind support
AYPC.F50.0950-01, pcs	2	-
AYPC.F50.0950-02, pcs	-	1
AYPC.F50.2905, pcs	8	4
Nut M10-A2 DIN934, pcs	4	2
Bolt M10x90-A2 DIN931, pcs	2	1
Washer 10-A2 DIN 125, pcs	4	2
Mounting anchor	4	2
Accessories for mullion joint		
Reinforced profile L=315mm, pcs	2	
Self-tapping screw 3,9x9,5, pcs	4	
Mullion plug stop AYPC.F50.0925, pcs	1	
Self-tapping screw 4,8x16, pcs	1	

\*Wind support must be installed additionally to the anchor support more than 5 kN.



Processing of AYPC.F50.0110 and AYPC.F50.0111 Mullions in the process of vertical connection using top hung installation scheme

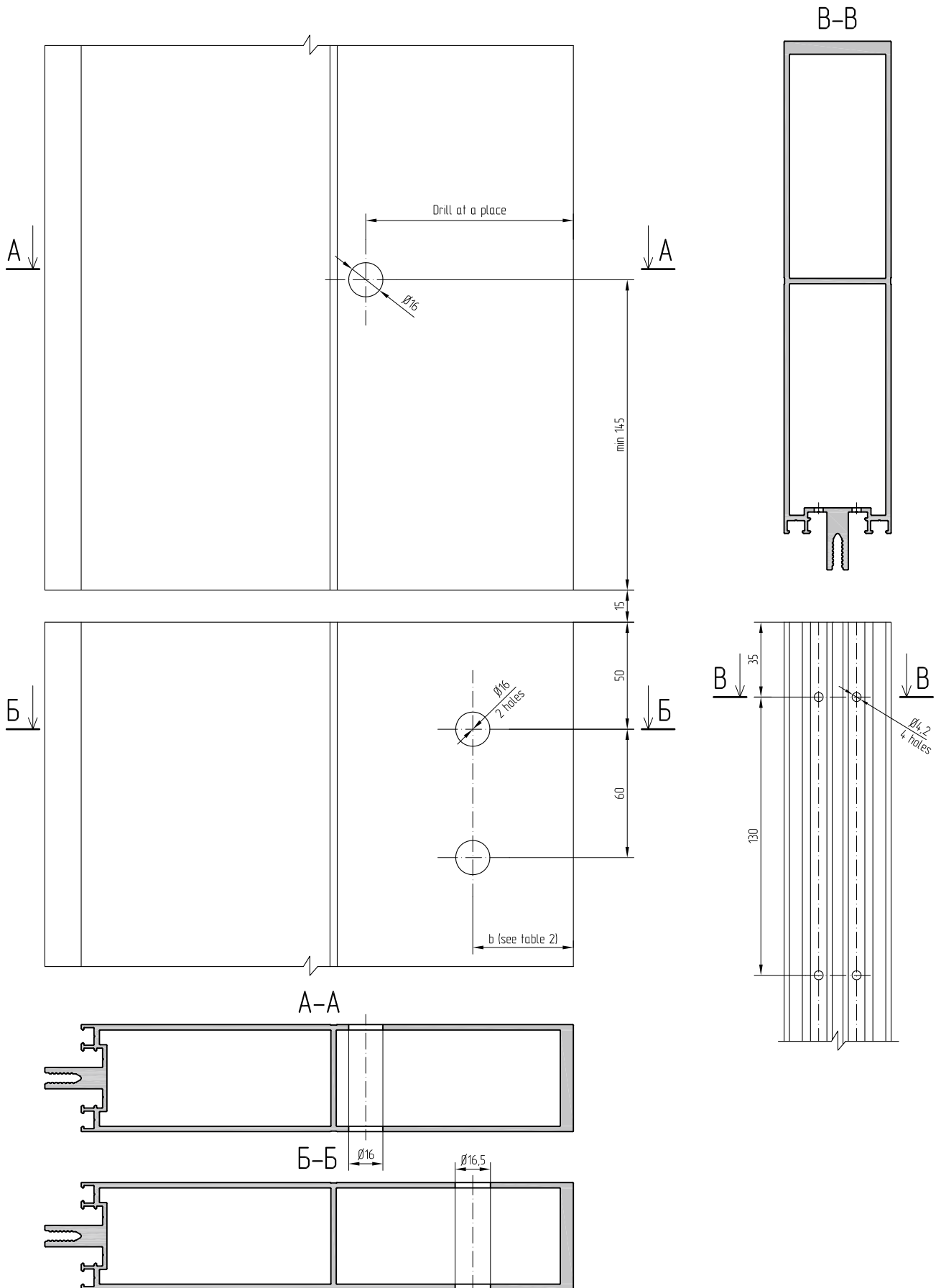

Processing of AYPC.F50.0305 and AYPC.F50.0306 Mullions in the process of vertical connection using top hung installation scheme

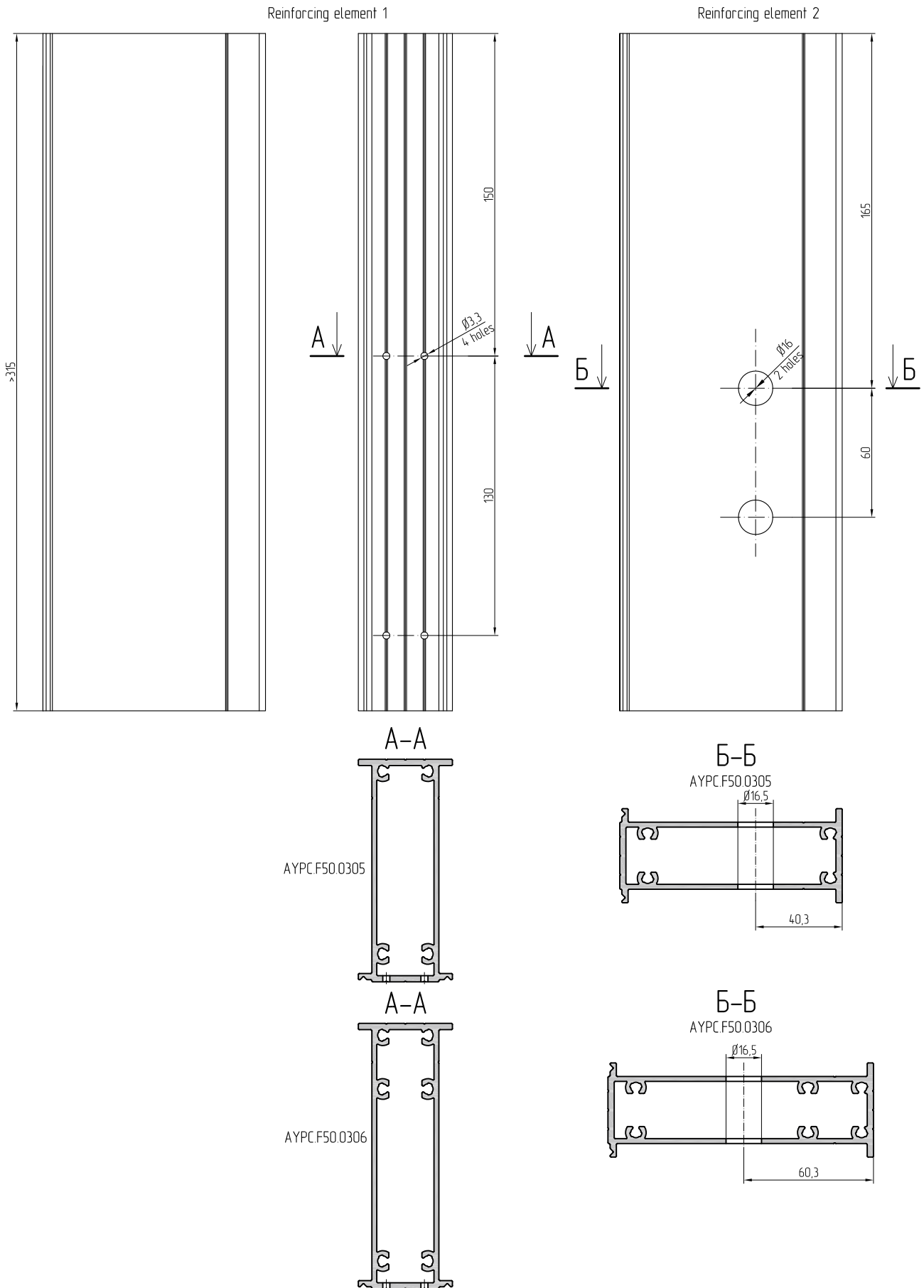

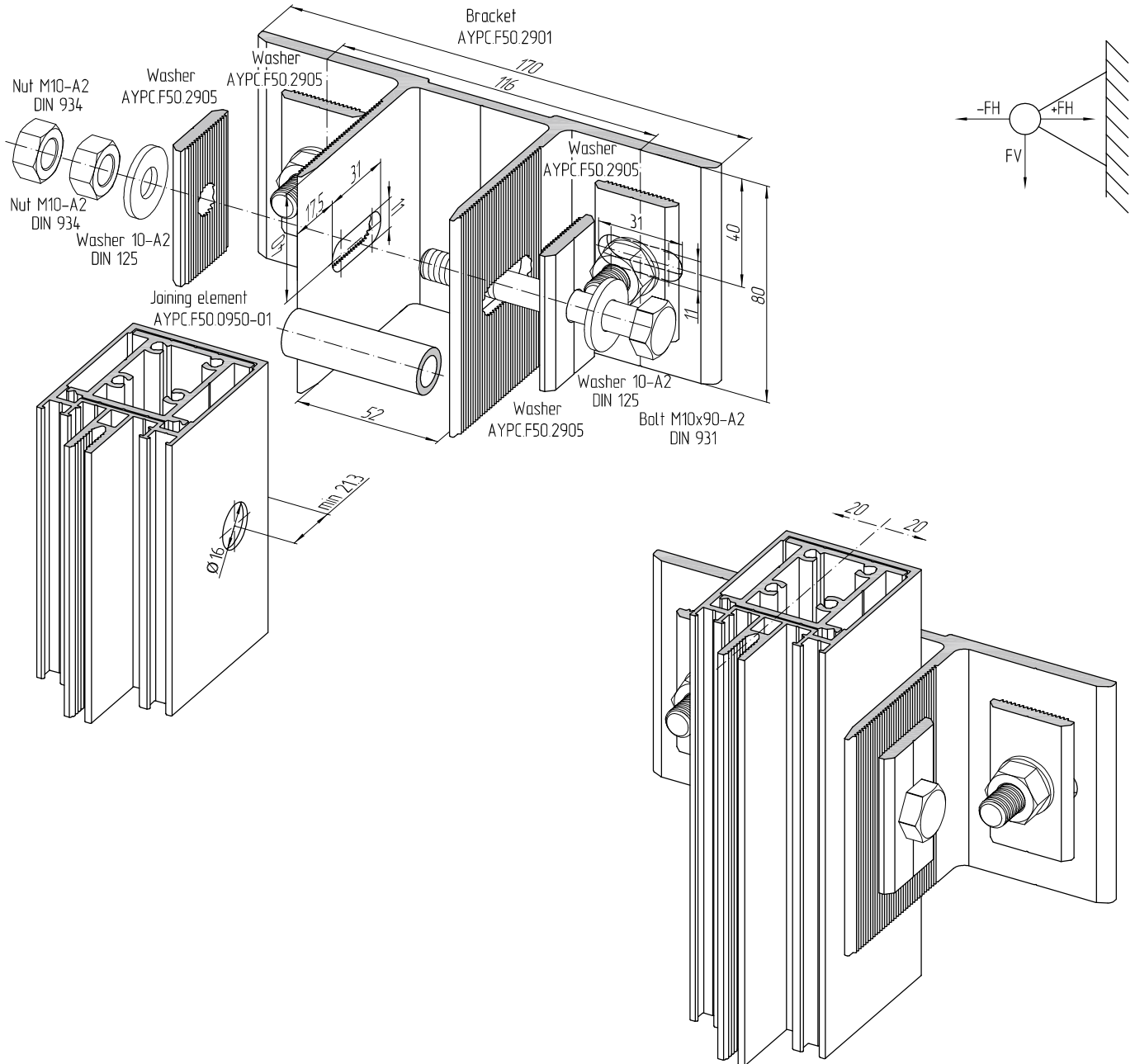

Value of minimal load is defined according to criteria of extreme point shift of the bearing up to 2 mm.

Acceptable support load is described for max distance between wall and mullion and displacement to extreme point of fastening elements.

Calculation of fastening elements is made separately.

Anchor support				Load		
Code	Article	Qty	Qty in pack, pcs	wind, kN		static, kN
11228400	AYPC.F50.2901	1	12			
11225700	AYPC.F50.0950-01	1	100			
11229200	AYPC.F50.2905	4	100			
18111400	Nut M10-A2 DIN 934	2	100	FH=+5	FH=-5	FV=5
18106300	Bolt M10x90-A2 DIN 931	1	100			
18106100	Washer 10-A2 DIN 125	2	100			

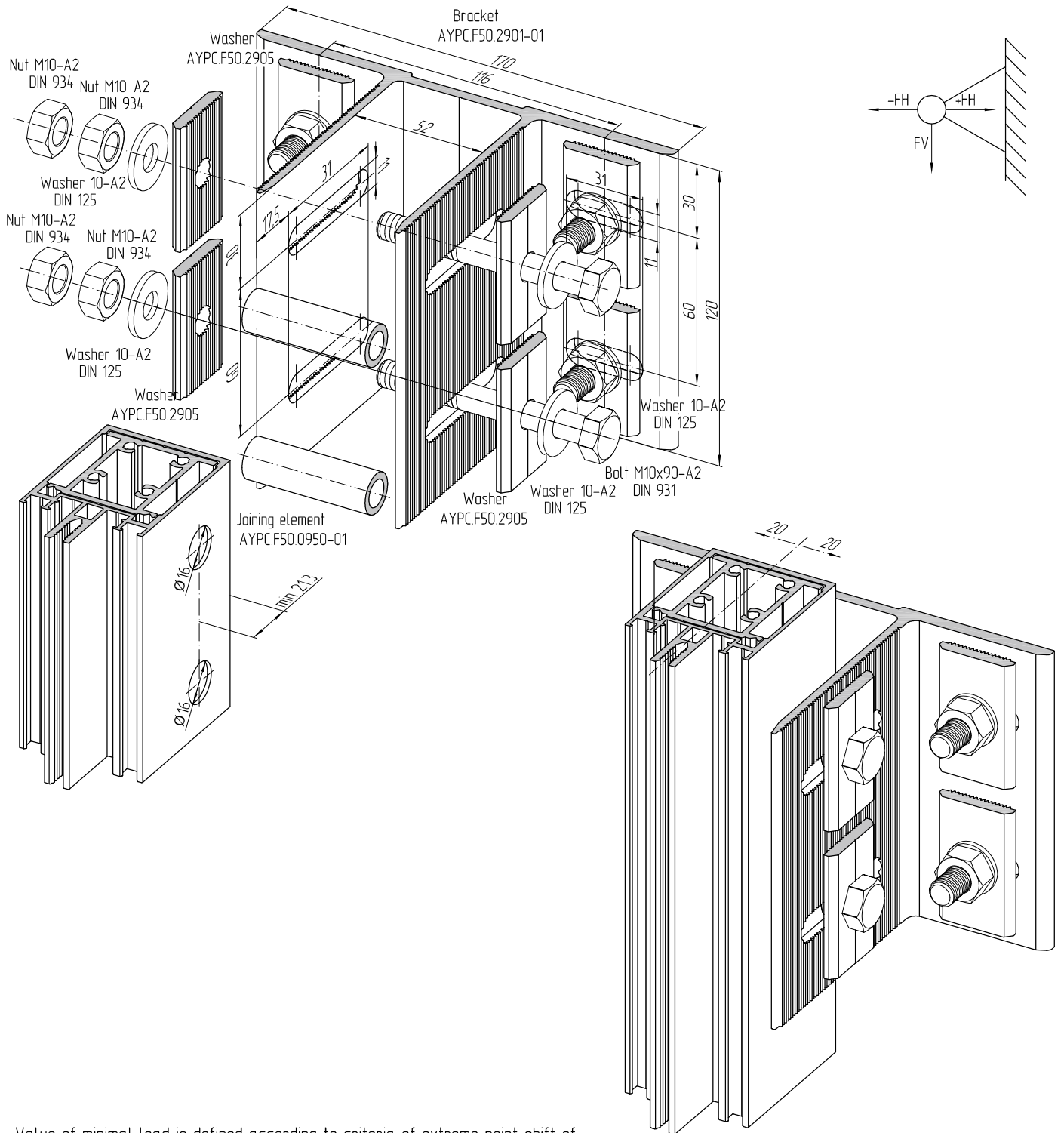

Value of minimal load is defined according to criteria of extreme point shift of the bearing up to 2 mm.

Acceptable support load is described for max distance between wall and mullion and displacement to extreme point of fastening elements.

Calculation of fastening elements is made separately.

Anchor support				Load		
Code	Article	Qty	Qty in pack, pcs	wind, kN		static, kN
11228500	AYPC.F50.2901-01	1	18			
11225700	AYPC.F50.0950-01	2	100			
11229200	AYPC.F50.2905	8	100			
18111400	Nut M10-A2 DIN 934	4	100	FH=+5	FH=-5	FV=6
18106300	Bolt M10x90-A2 DIN 931	2	100			
18106100	Washer 10-A2 DIN 125	4	100			

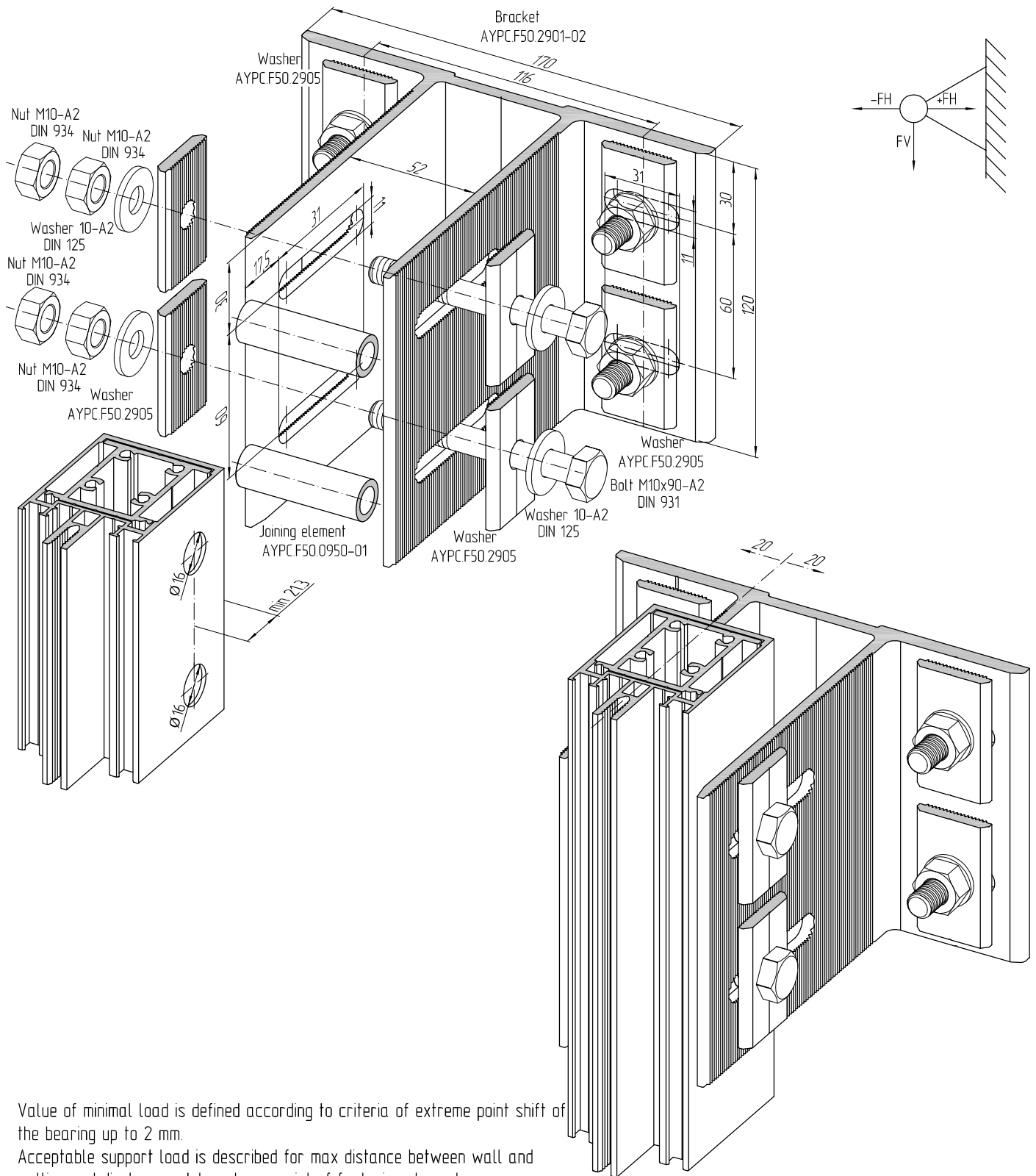

Value of minimal load is defined according to criteria of extreme point shift of the bearing up to 2 mm.  
Acceptable support load is described for max distance between wall and mullion and displacement to extreme point of fastening elements.  
Calculation of fastening elements is made separately.

Anchor support				Load		
Code	Article	Qty	Qty in pack, pcs	wind, kN		static, kN
11228600	AYPC.F50.2901-02	1	12	FH=+5	FH=-5	FV=6
11225700	AYPC.F50.0950-01	2	100			
11229200	AYPC.F50.2905	8	100			
18111400	Nut M10-A2 DIN 934	4	100			
18106300	Bolt M10x90-A2 DIN 931	2	100			
18106100	Washer 10-A2 DIN 125	4	100			

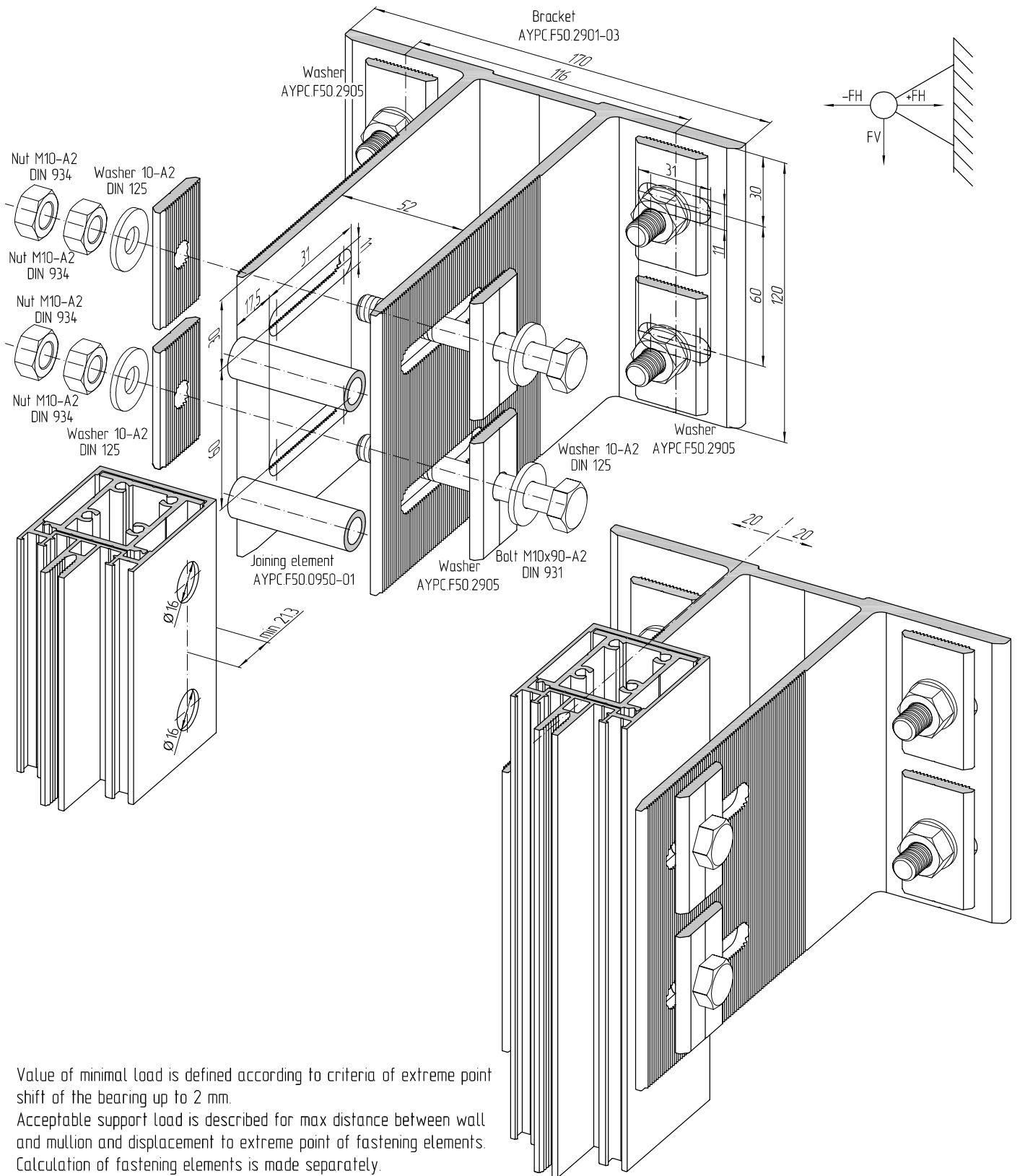

Value of minimal load is defined according to criteria of extreme point shift of the bearing up to 2 mm.  
Acceptable support load is described for max distance between wall and mullion and displacement to extreme point of fastening elements.  
Calculation of fastening elements is made separately.

Anchor support				Load		
Code	Article	Qty	Qty in pack, pcs	wind, kN		static, kN
11231100	AYPC.F50.2901-03	1	12			
11225700	AYPC.F50.0950-01	2	100			
11229200	AYPC.F50.2905	8	100			
18111400	Nut M10-A2 DIN 934	4	100	FH=+5	FH=-5	FV=6
18106300	Bolt M10x90-A2 DIN 931	2	100			
18106100	Washer 10-A2 DIN 125	4	100			

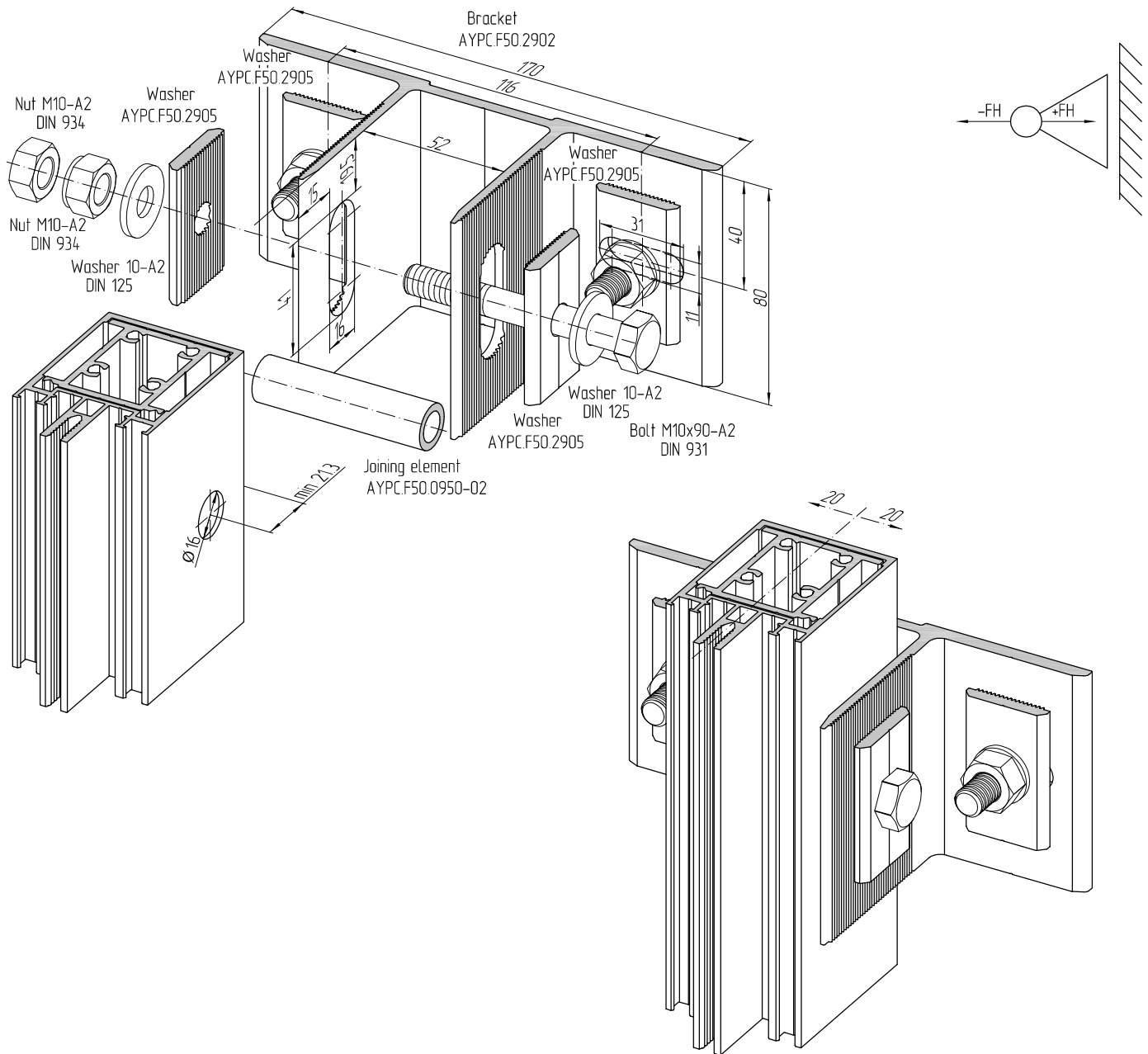

Calculation of fastening elements is made separately.

Movable anchor support				Load	
Code	Article	Qty	Qty in pack, pcs	wind, kN	
11228800	AYPC.F50.2902	1	12	FH=+5    FH=-5	
11231200	AYPC.F50.0950-03	1	100		
11229200	AYPC.F50.2905	4	100		
18111400	Nut M10-A2 DIN 934	2	100		
18106300	Bolt M10x90-A2 DIN 931	1	100		
18106100	Washer 10-A2 DIN 125	2	100		

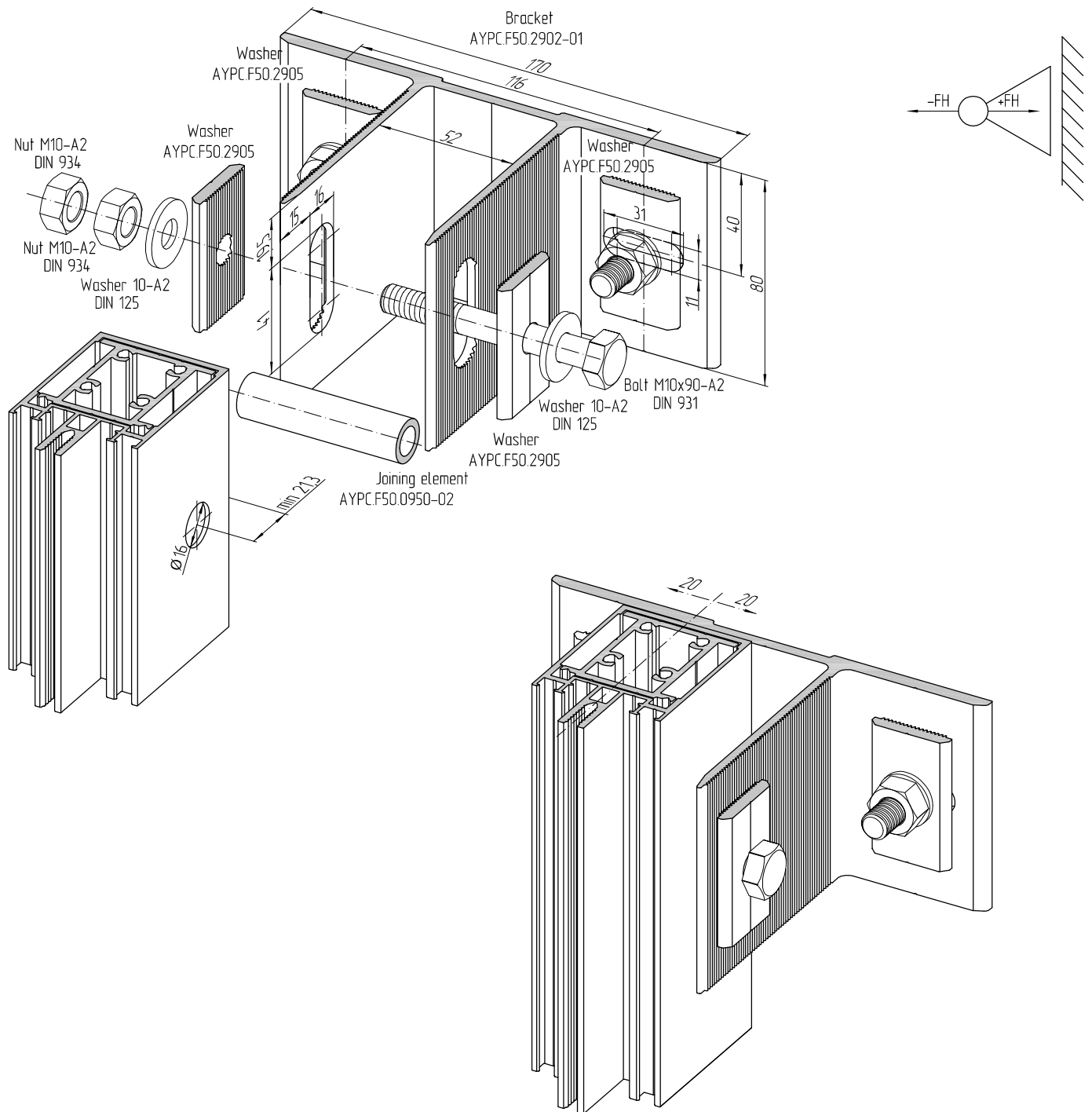

Calculation of fastening elements is made separately.

Movable anchor support				Load	
Code	Article	Qty	Qty in pack, pcs	wind, kN	
11228900	AYPC.F50.2902-01	1	6		
11225700	AYPC.F50.0950-03	1	100		
11229200	AYPC.F50.2905	4	100		
18111400	Nut M10-A2 DIN 934	2	100	FH=+5	FH=-5
18106300	Bolt M10x90-A2 DIN 931	1	100		
18106100	Washer 10-A2 DIN 125	2	100		



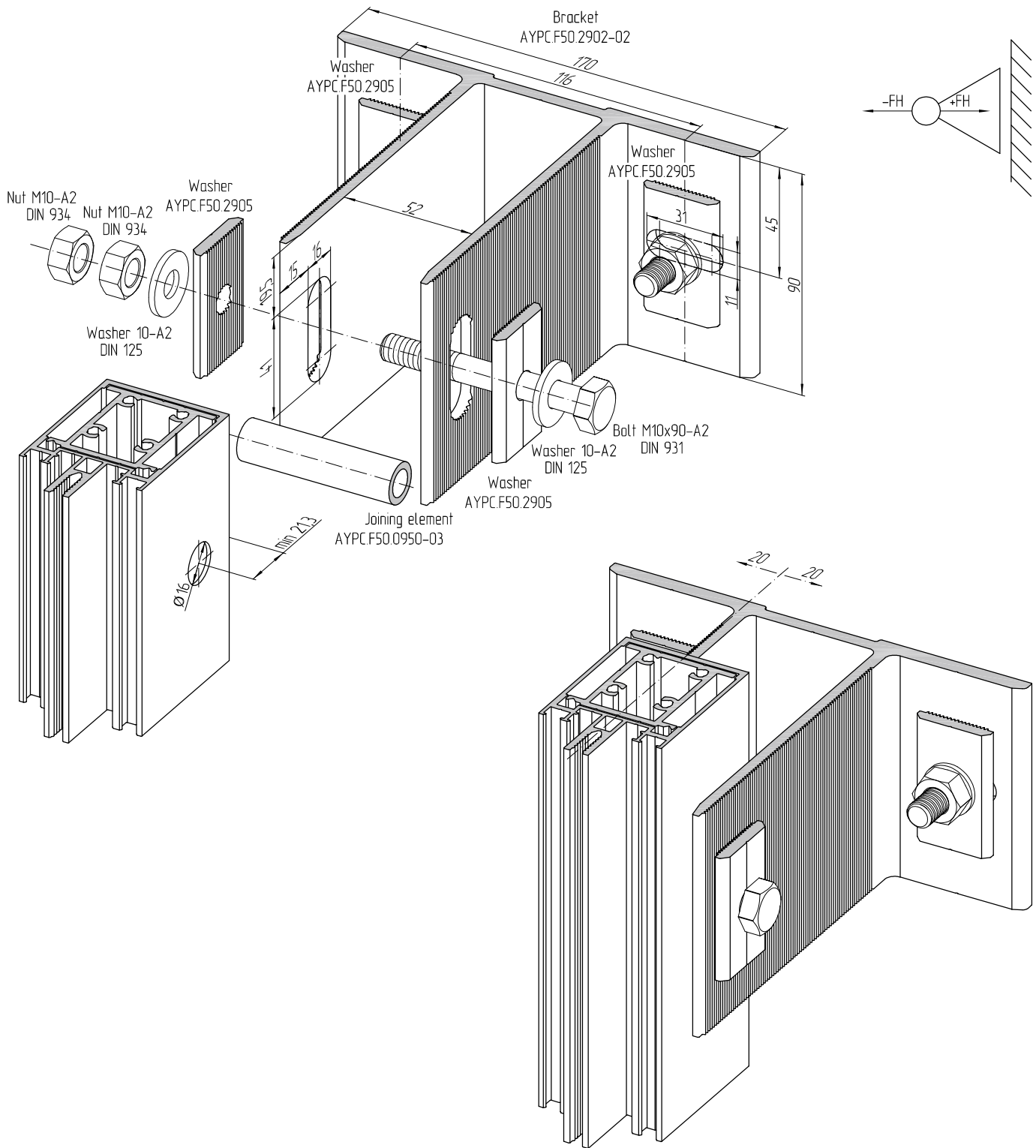

Calculation of fastening elements is made separately.

Movable anchor support				wind, kN	
Code	Article	Qty	Qty in pack, pcs		
11229000	AYPC.F50.2902-02	1	4		
11225700	AYPC.F50.0950-03	1	100		
11229200	AYPC.F50.2905	4	100		
18111400	Nut M10-A2 DIN 934	2	100	FH=+5	FH=-5
18106300	Bolt M10x90-A2 DIN 931	1	100		
18106100	Washer 10-A2 DIN 125	2	100		

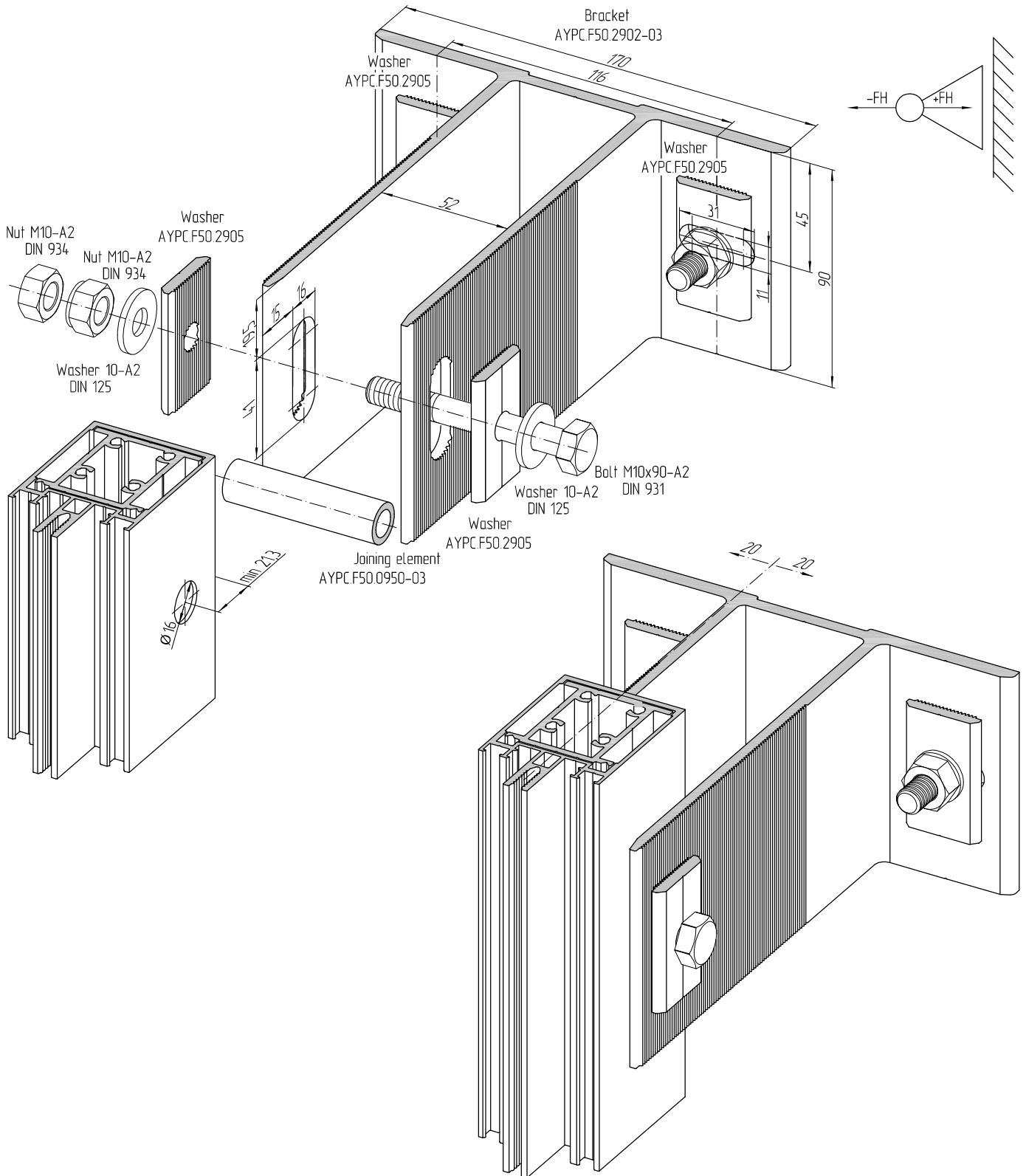

Calculation of fastening elements is made separately.

Movable anchor support				wind, kN	
Code	Article	Qty	Qty in pack, pcs		
11229100	AYPC.F50.2902-03	1	6		
11225700	AYPC.F50.0950-03	1	100		
11229200	AYPC.F50.2905	2	100		
18111400	Nut M10-A2 DIN 934	2	100	FH=+5	FH=-5
18106300	Bolt M10x90-A2 DIN 931	1	100		
18106100	Washer 10-A2 DIN 125	2	100		

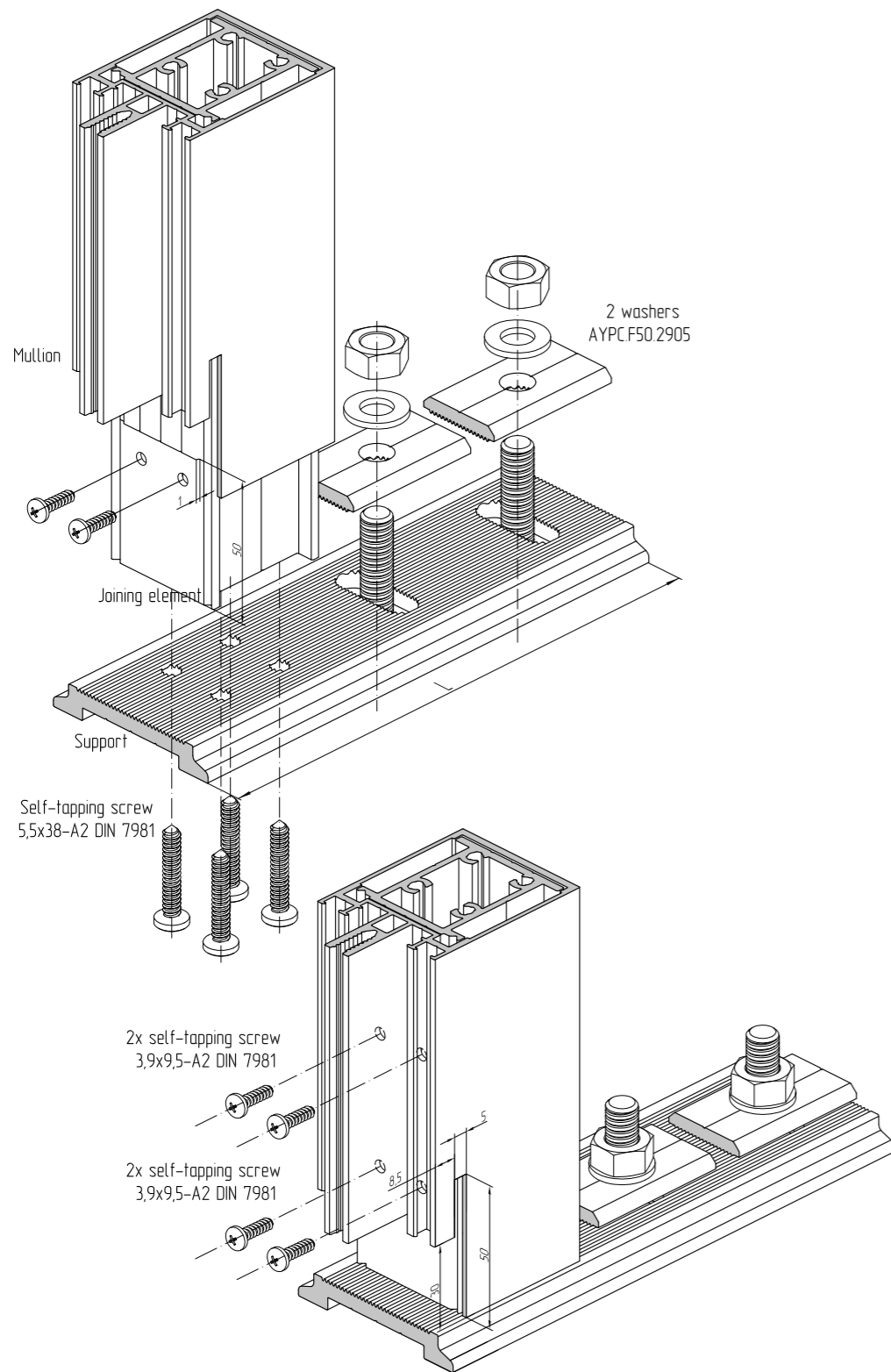

Support made of AYPC.F50.0724 profile

Article	Length L, mm	A, mm	Fig.	Weight, kg
AYPC.F50.2903	188	25	1	0,197
AYPC.F50.2903-01	208	45	1	0,219
AYPC.F50.2903-02	228	65	1	0,241
AYPC.F50.2903-03	248	85	1	0,263
AYPC.F50.2903-04	268	80	2	0,284
AYPC.F50.2903-05	298	110	2	0,317
AYPC.F50.2903-06	323	135	2	0,345

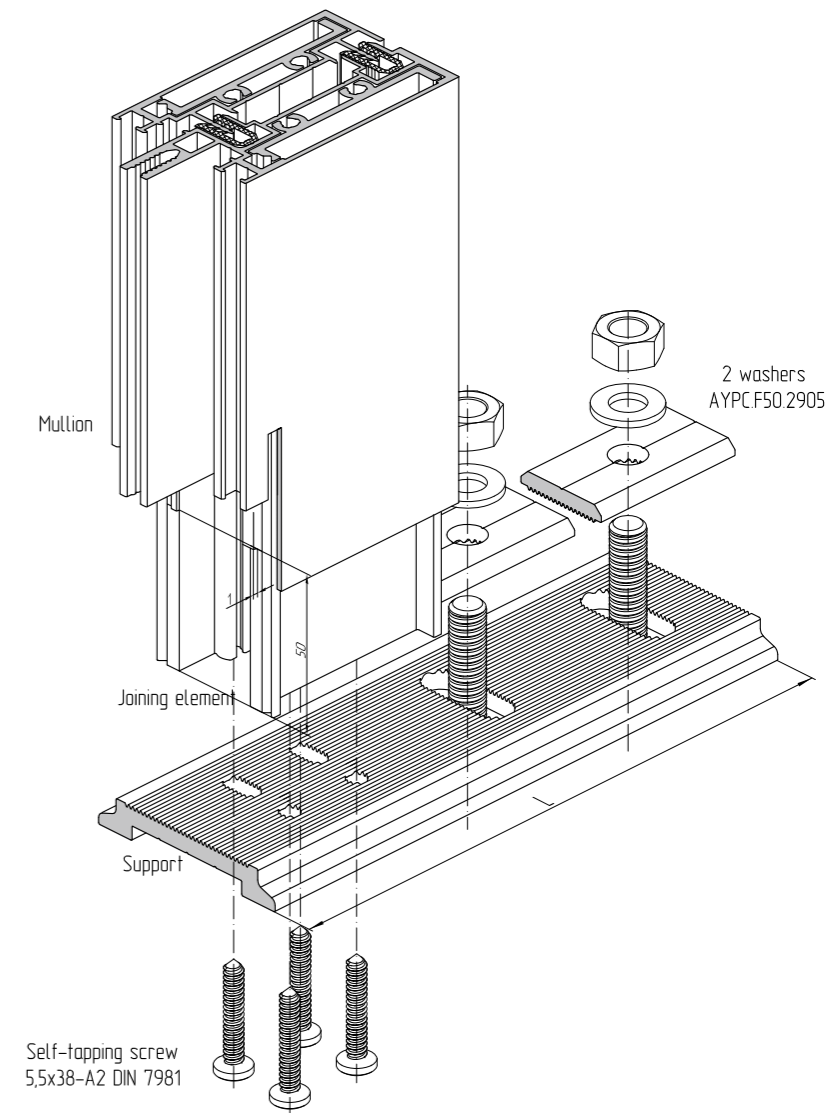
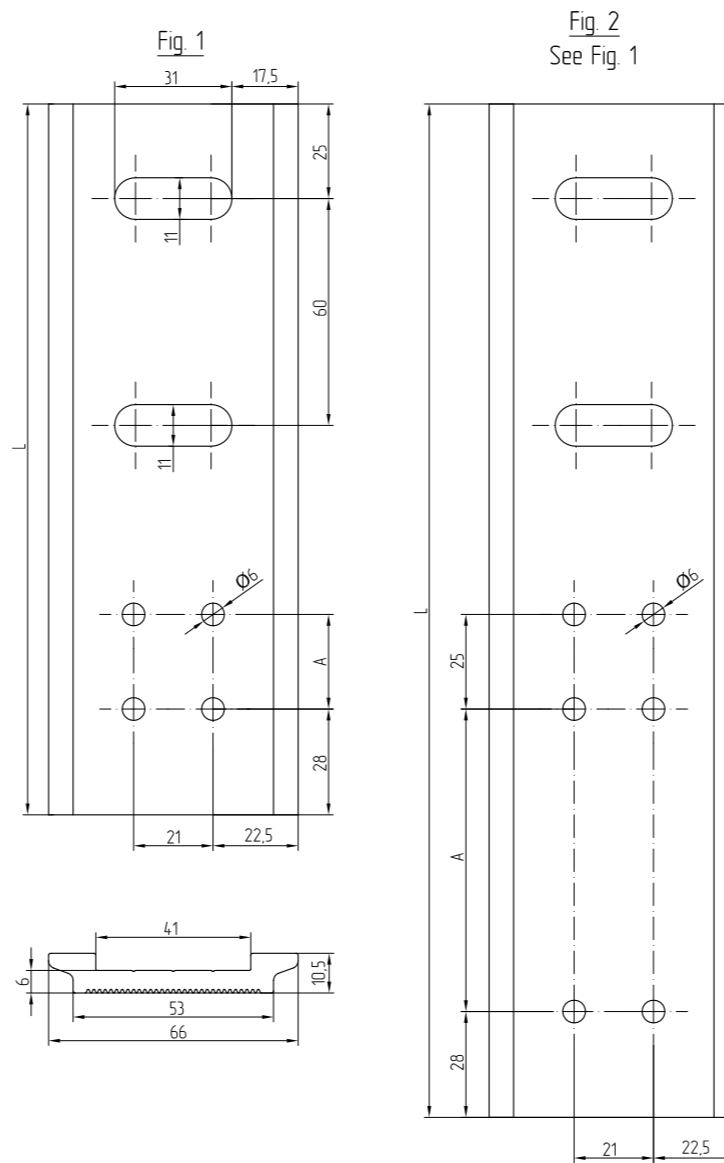

The support for expansion mullion is to be worked according to the drawing

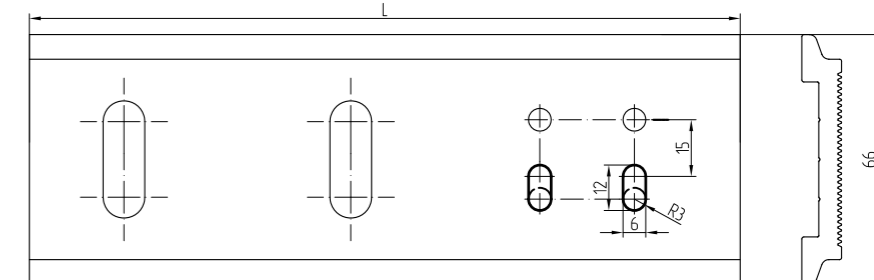

Support made of AYPC.F50.0724 profile

Code	Article	Length L, mm	Mullion	Joining element	Color	00 Qty in pack, pcs
11229300	AYPC.F50.2903	188	AYPC.F50.0102	AYPC.F50.0302		35
11229400	AYPC.F50.2903-01	208	AYPC.F50.0103	AYPC.F50.0303		24
11229500	AYPC.F50.2903-02	228	AYPC.F50.0104	AYPC.F50.0304		24
11229600	AYPC.F50.2903-03	248	AYPC.F50.0105	AYPC.F50.0305		24
11229700	AYPC.F50.2903-04	268	AYPC.F50.0106	AYPC.F50.0306		24
11229800	AYPC.F50.2903-05	298	AYPC.F50.0107	AYPC.F50.0307		24
11229900	AYPC.F50.2903-06	323	AYPC.F50.0108	AYPC.F50.0308		24

Support made of AYPC.F50.0724 profile

Article	Length L, mm	Mullion	Joining element
AYPC.F50.2903	188	AYPC.F50.0113 AYPC.F50.0123	AYPC.F50.0313
AYPC.F50.2903-01	208	AYPC.F50.0114 AYPC.F50.0124	AYPC.F50.0314
AYPC.F50.2903-02	228	AYPC.F50.0115 AYPC.F50.0125	AYPC.F50.0315
AYPC.F50.2903-03	248	AYPC.F50.0116 AYPC.F50.0126	AYPC.F50.0316

Support made of AYPF50.0723 profile				
Article	Length L, mm	A, mm	Fig	Weight, kg
AYPC.F50.2904	128	25	1	0,352
AYPC.F50.2904-01	148	45	1	0,410
AYPC.F50.2904-02	168	65	1	0,468
AYPC.F50.2904-03	188	85	1	0,526
AYPC.F50.2904-04	208	80	2	0,584
AYPC.F50.2904-05	238	110	2	0,671
AYPC.F50.2904-06	263	135	2	0,744
AYPC.F50.2904-07	285	85	3	0,795
AYPC.F50.2904-08	325	80	4	0,909

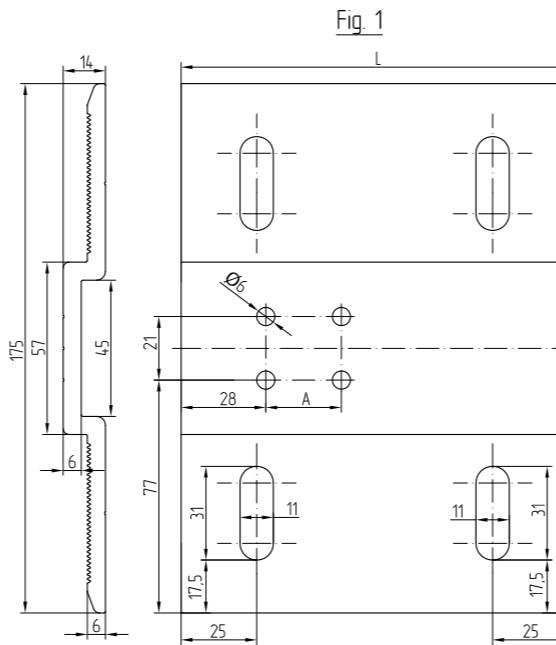
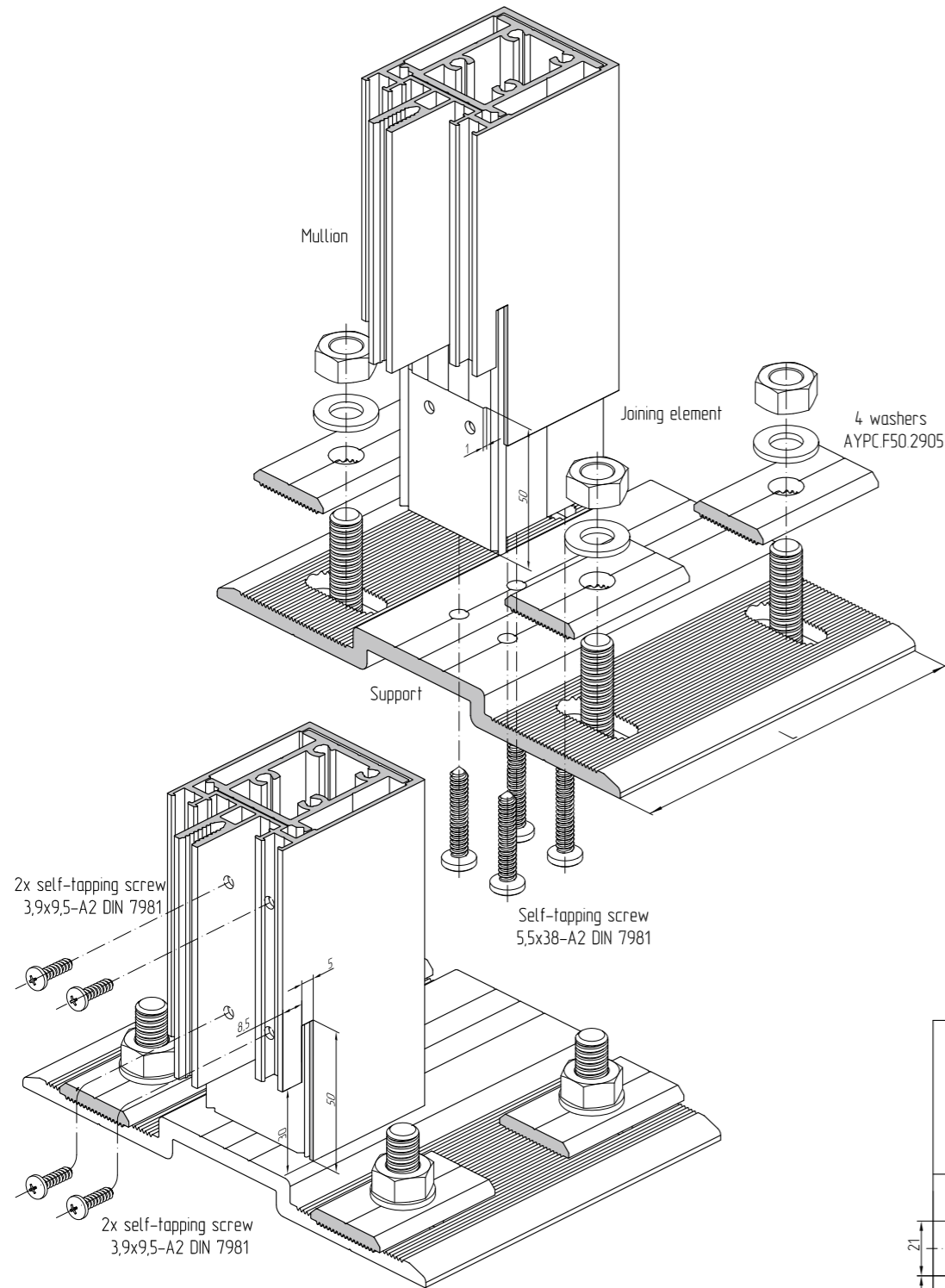
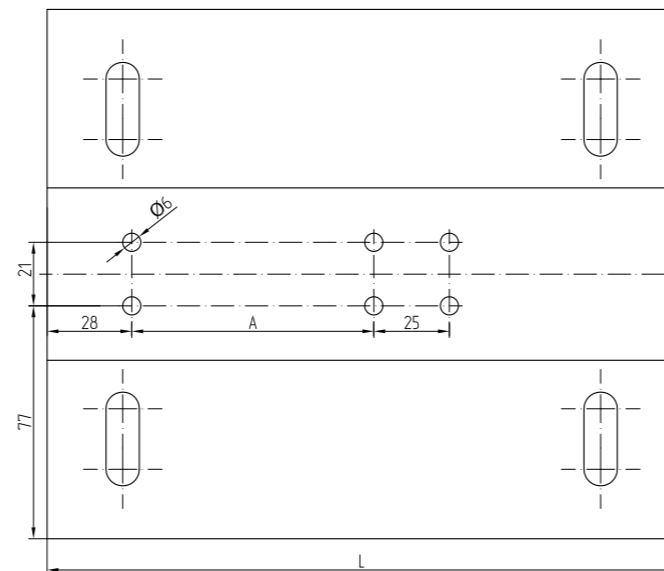
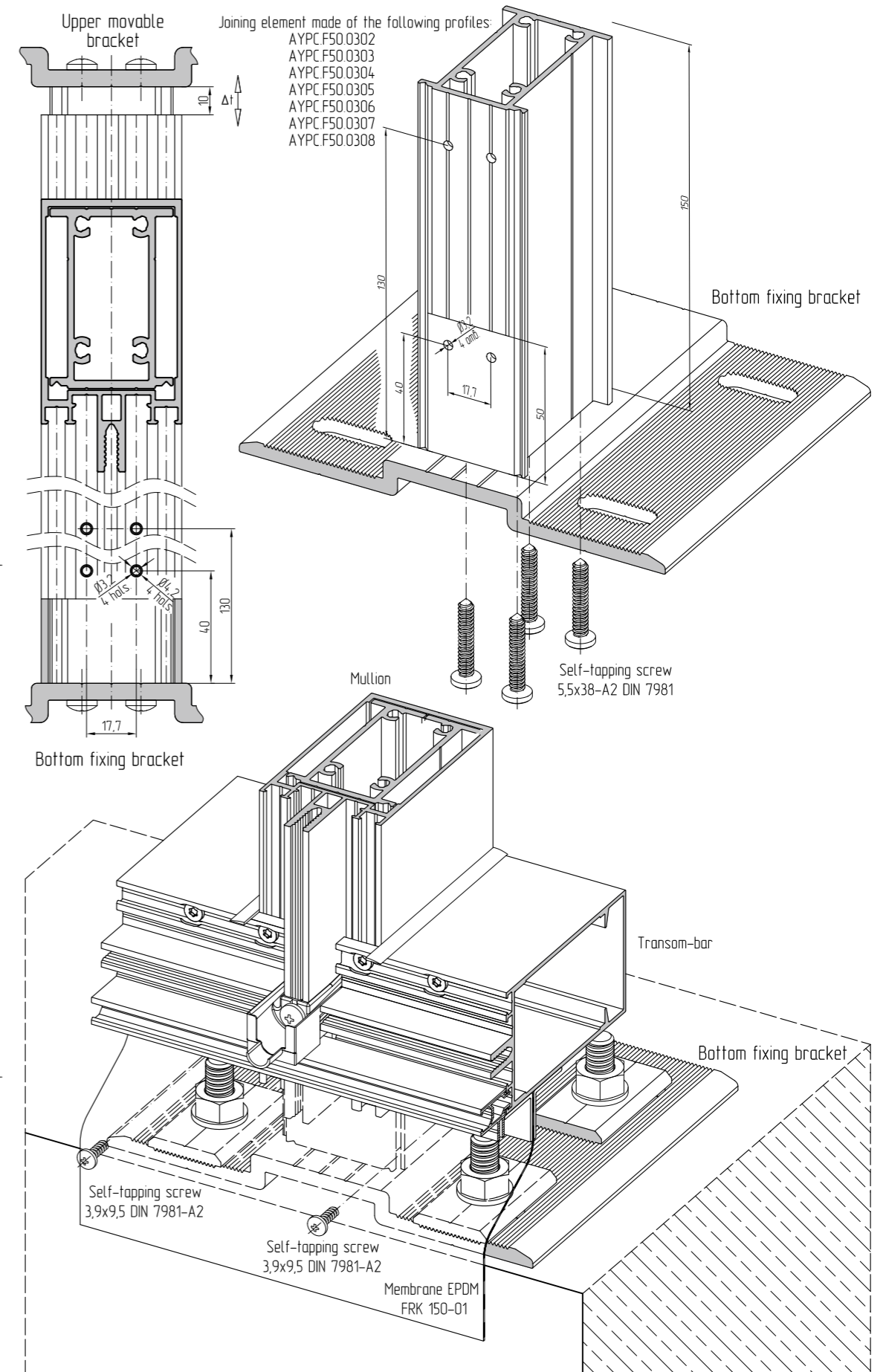

Fig. 2  
See Fig. 1



Support made of AYPF50.0723 profile					Color	00
Code	Article	Length L, mm	Mullion	Joining element	Qty in pack, pcs	
11230000	AYPC.F50.2904	128	AYPC.F50.0102	AYPC.F50.0302	10	
11230100	AYPC.F50.2904-01	148	AYPC.F50.0103	AYPC.F50.0303	10	
11230200	AYPC.F50.2904-02	168	AYPC.F50.0104	AYPC.F50.0304	10	
11230300	AYPC.F50.2904-03	188	AYPC.F50.0105	AYPC.F50.0305	10	
11230400	AYPC.F50.2904-04	208	AYPC.F50.0106	AYPC.F50.0306	10	
11230500	AYPC.F50.2904-05	238	AYPC.F50.0107	AYPC.F50.0307	10	
11230600	AYPC.F50.2904-06	263	AYPC.F50.0108	AYPC.F50.0308	10	
11234000	AYPC.F50.2904-07	285	AYPC.F50.0110	AYPC.F50.0305	10	
11234100	AYPC.F50.2904-08	325	AYPC.F50.0111	AYPC.F50.0306	10	





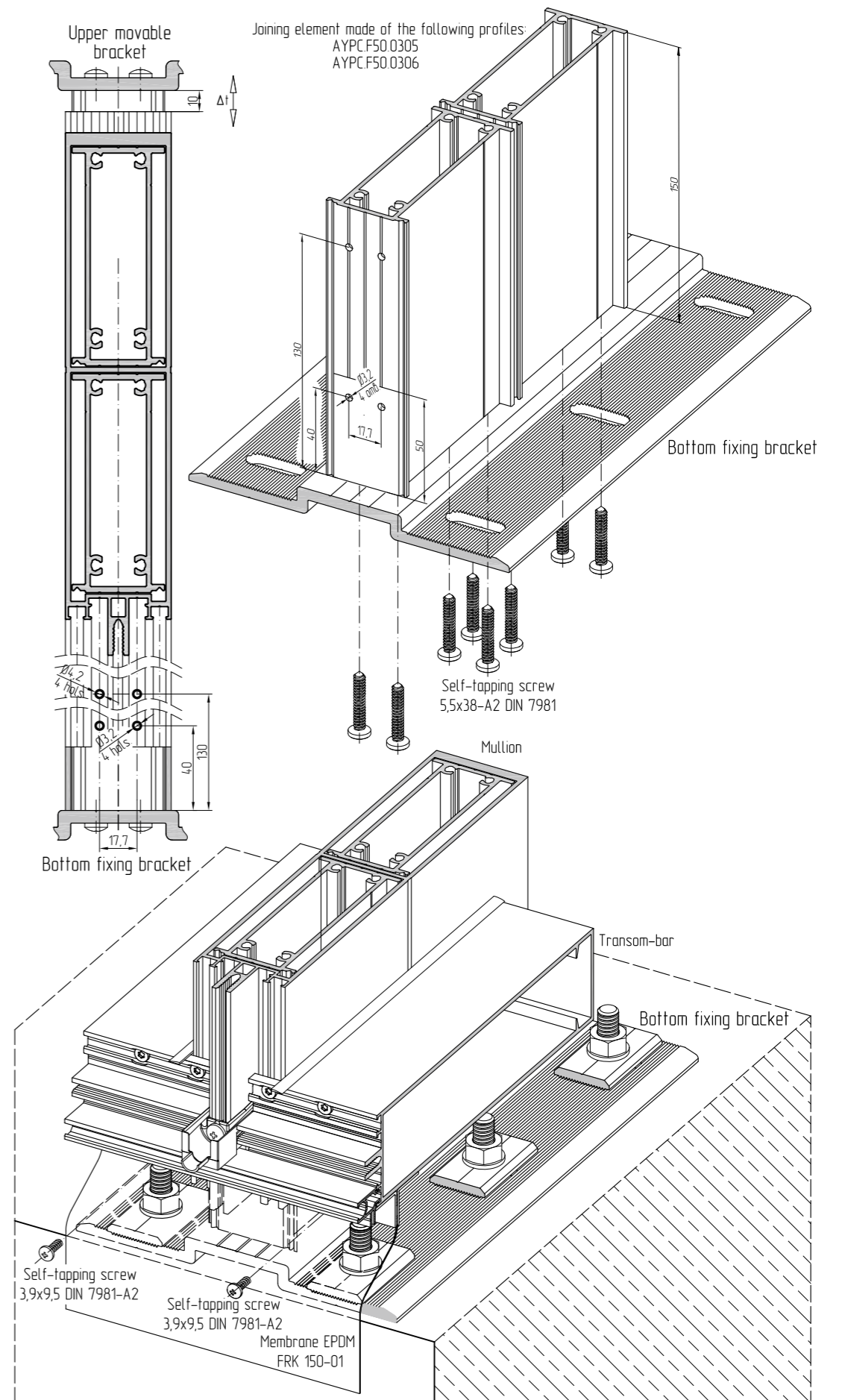
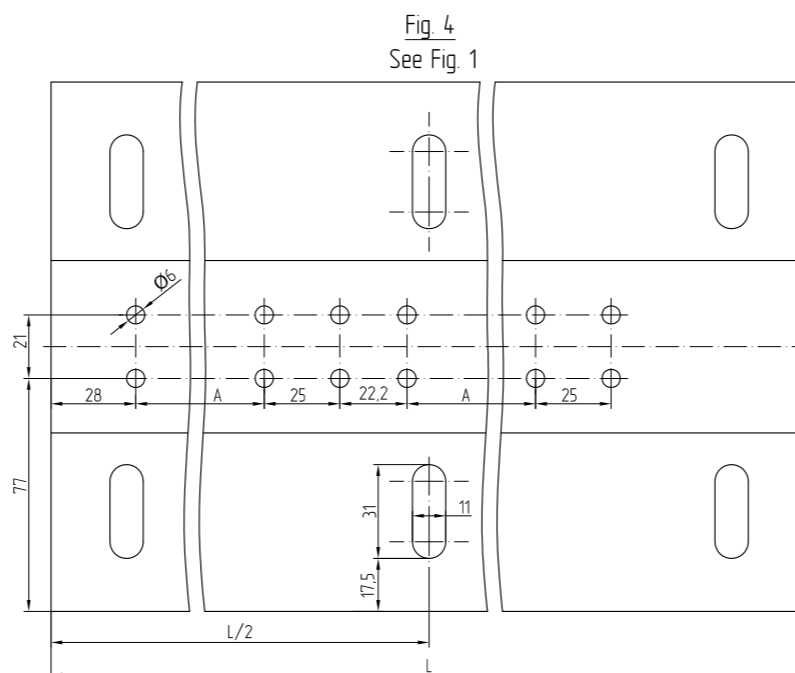
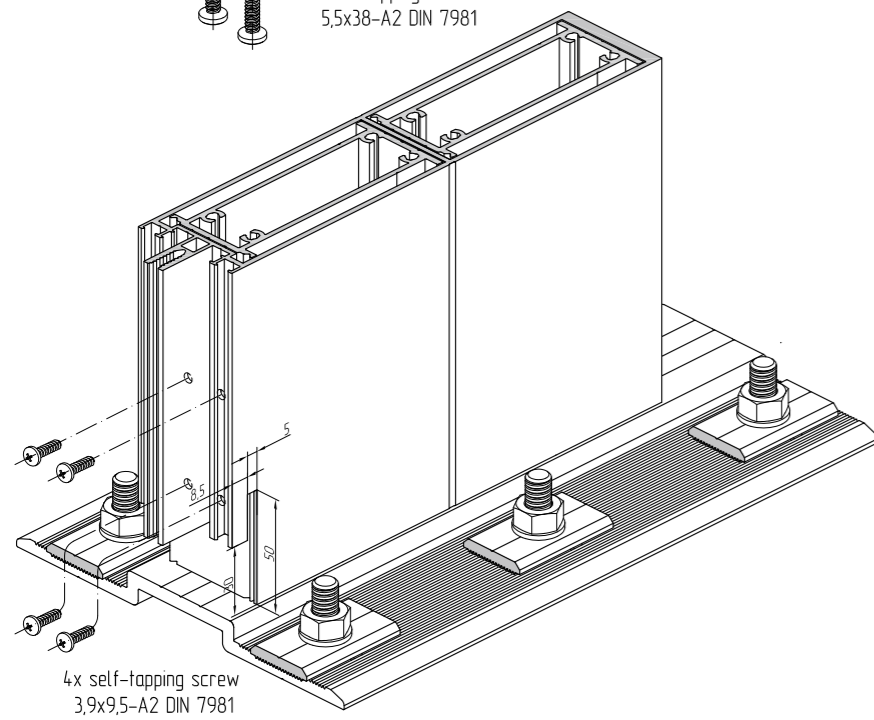
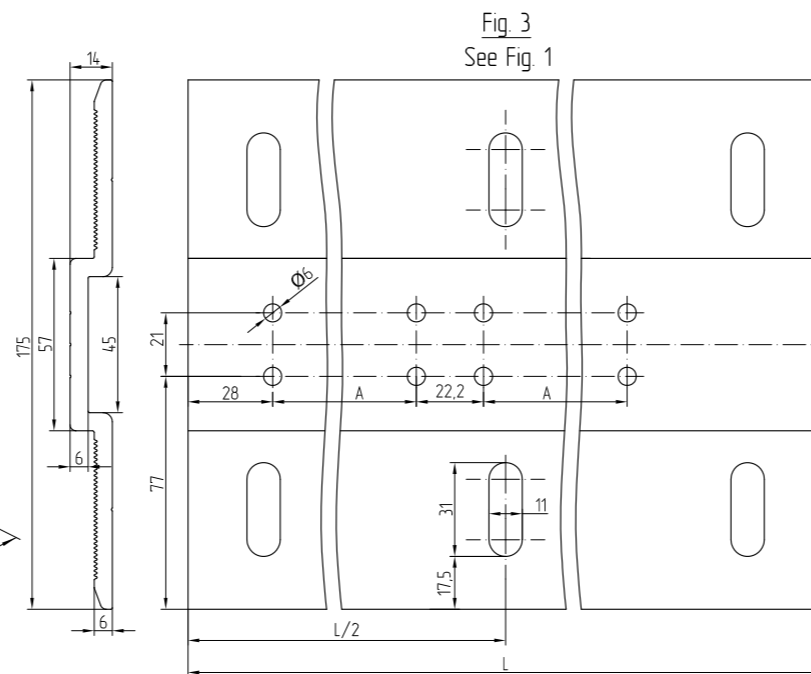
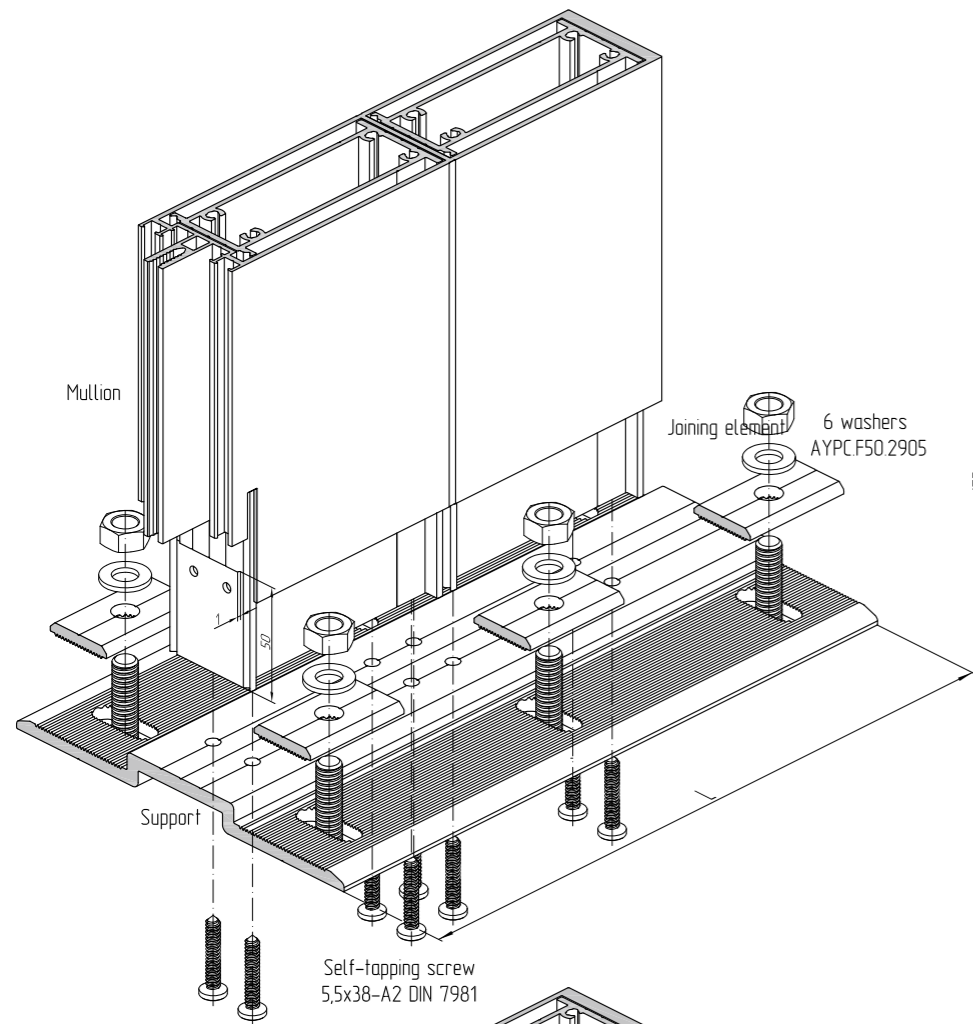

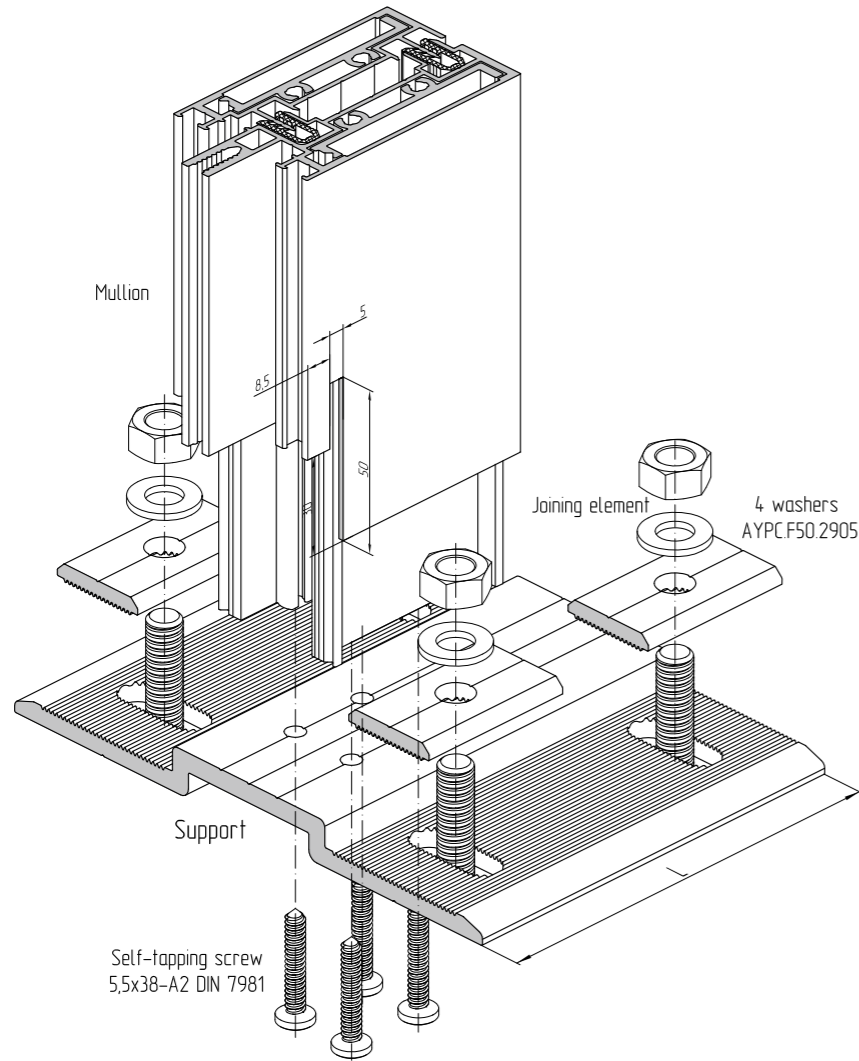

The support for expansion mullion is to be worked according to the drawing

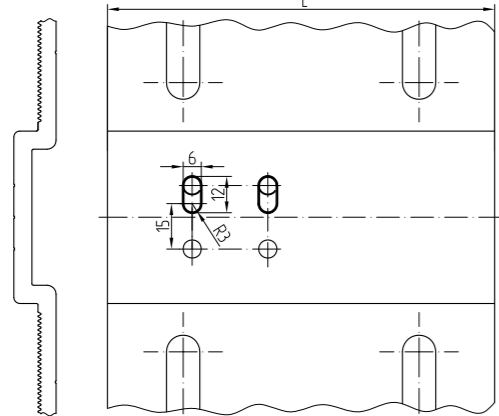

Support made of AYPC.F50.0723 profile			
Article	Length L, mm	Mullion	Joining element
AYPC.F50.2904	128	AYPC.F50.0113 AYPC.F50.0123	AYPC.F50.0313
AYPC.F50.2904-01	148	AYPC.F50.0114 AYPC.F50.0124	AYPC.F50.0314
AYPC.F50.2904-02	168	AYPC.F50.0115 AYPC.F50.0125	AYPC.F50.0315
AYPC.F50.2904-03	188	AYPC.F50.0116 AYPC.F50.0126	AYPC.F50.0316

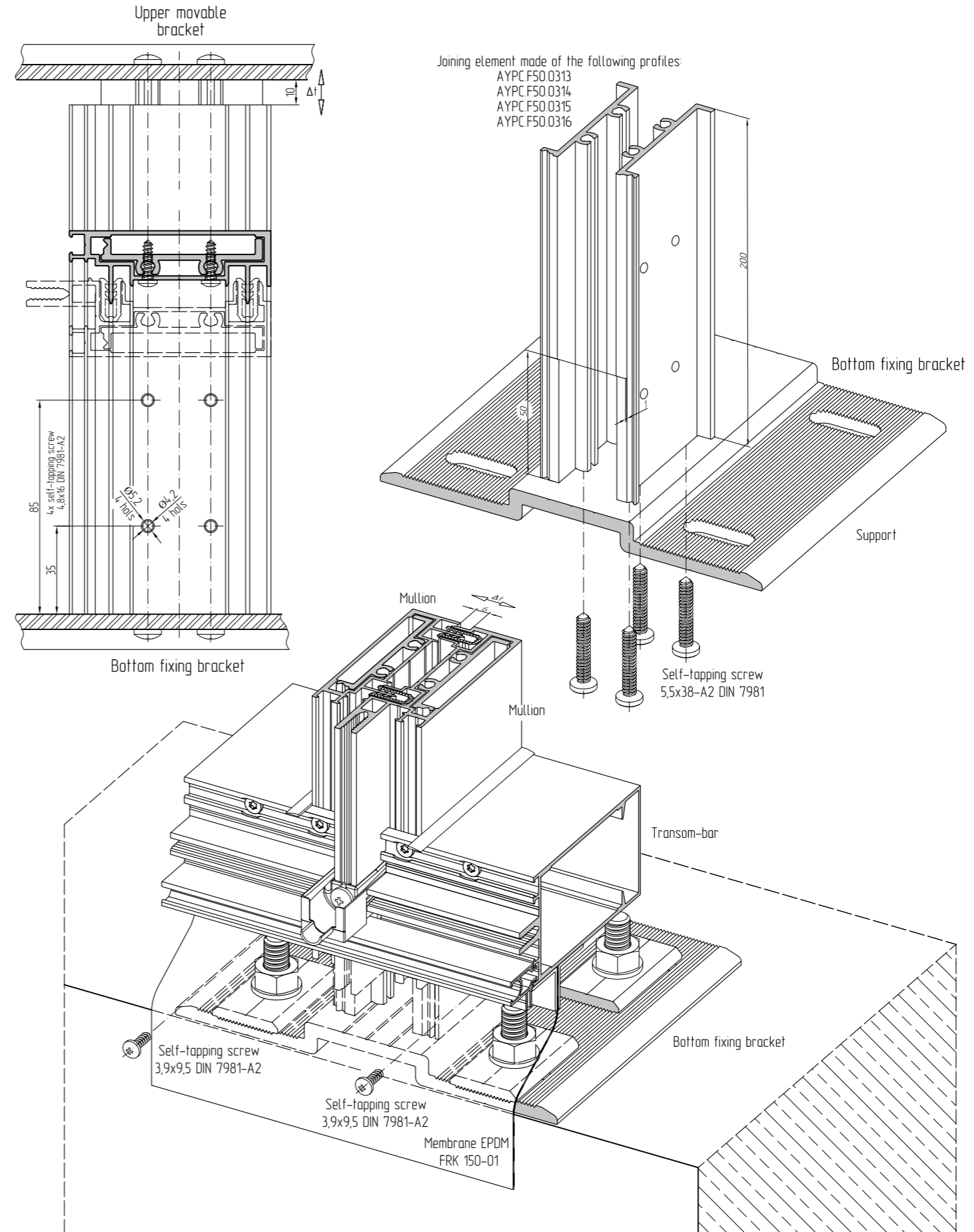

Upper movable bracket

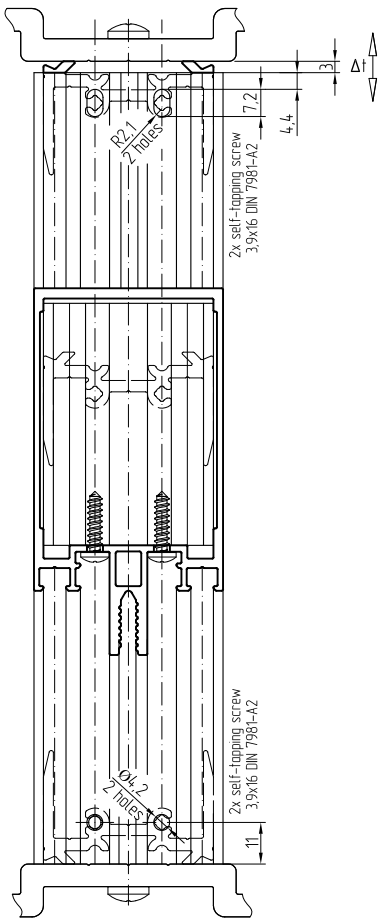

Bottom fixing bracket

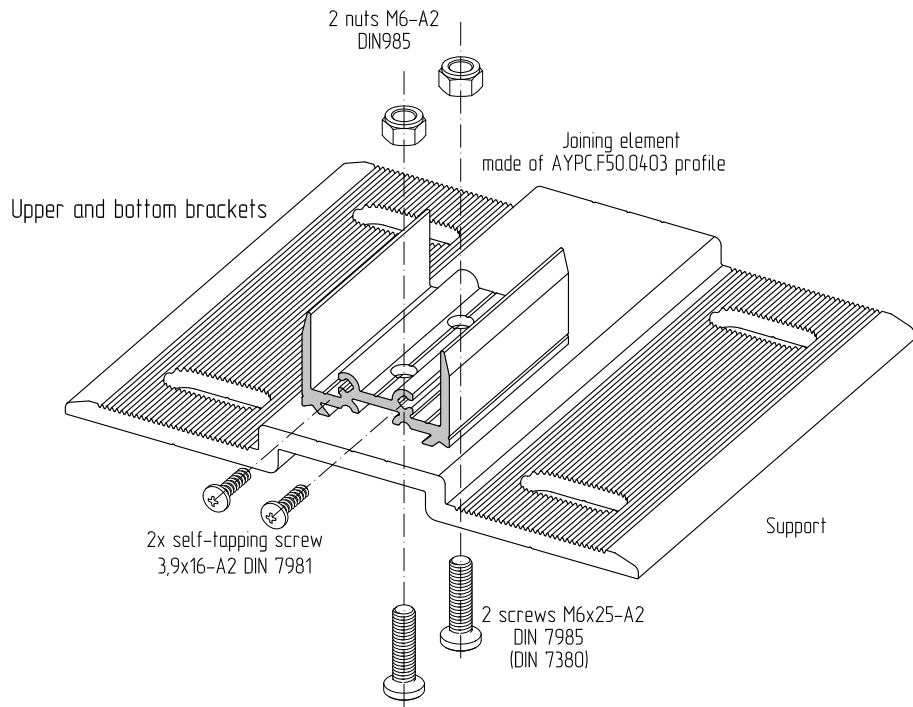

Mullion

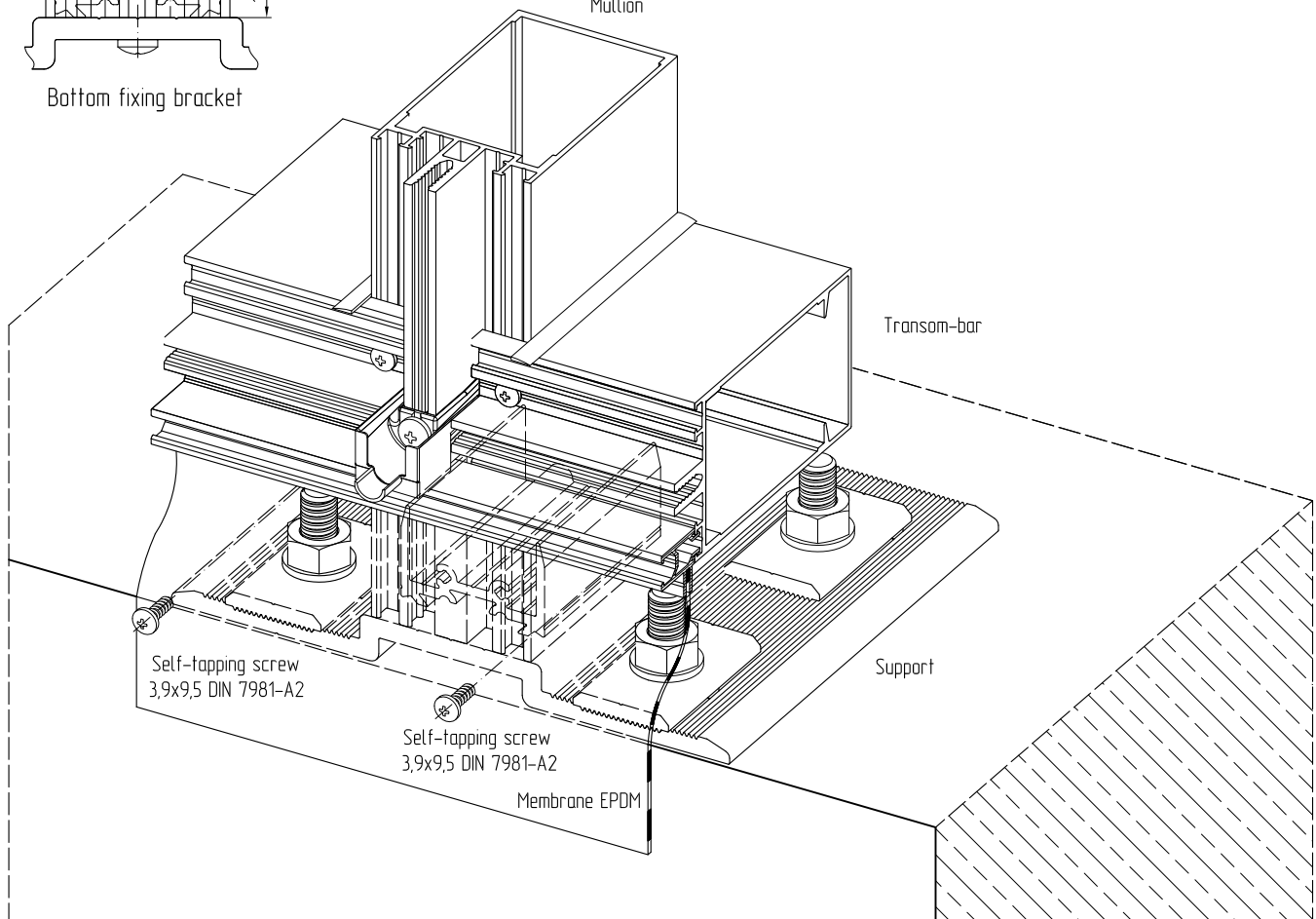







**ALUFACH** ALTF50  
CURTAIN WALL  
SYSTEM



## GASKETS (1:1)

04

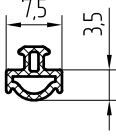
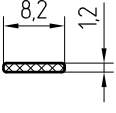
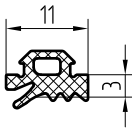
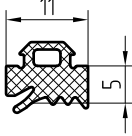
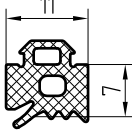
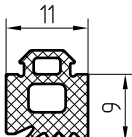
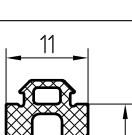
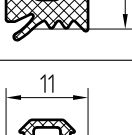
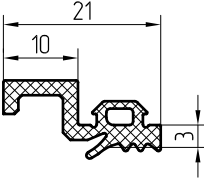
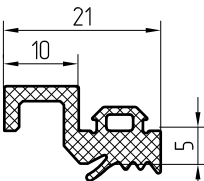

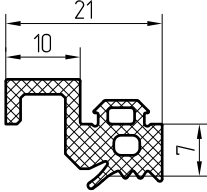
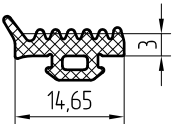
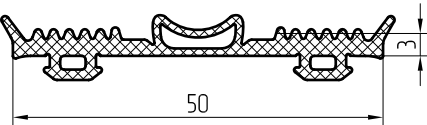
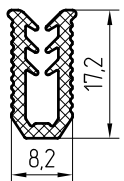
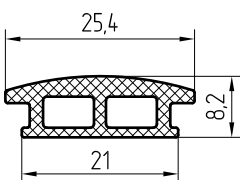
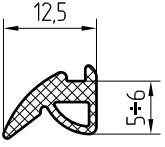
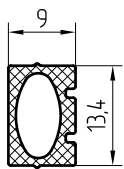
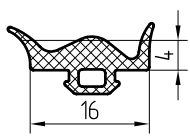
Gasket article	Code	Section	Weight, kg/m	Material	Qty in pack, m	Description
FRK07	10210600		0,031	EPDM	400	Rubber gasket
FRK13	10211200		0,013	EPDM	300	Rubber gasket
FRK14	11215100		0,056	EPDM	300	Rubber gasket
FRK15	11215200		0,083	EPDM	200	Rubber gasket
FRK16	11215300		0,100	EPDM	175	Rubber gasket
FRK17	11215400		0,120	EPDM	150	Rubber gasket
FRK18	11215500		0,138	EPDM	125	Rubber gasket
FRK19	11215600		0,155	EPDM	100	Rubber gasket
FRK20	11215700		0,095	EPDM	175	Rubber gasket
FRK21	11215800		0,133	EPDM	125	Rubber gasket

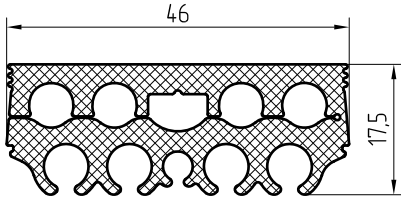
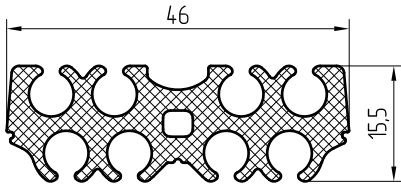
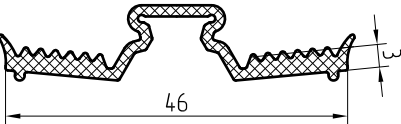
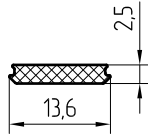
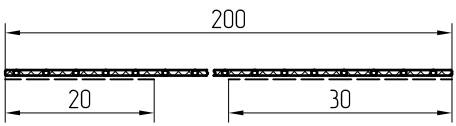
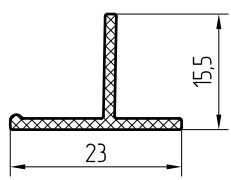
Gasket article	Code	Section	Weight, kg/m	Material	Qty in pack, m	Description
FRK22	11215900		0,158	EPDM	100	Rubber gasket
FRK24	11216100		0,080	EPDM	225	Rubber gasket
FRK25	11216200		0,208	EPDM	75	Rubber gasket
FRK28	10413200		0,106	EPDM	150	Rubber gasket
FRK32	10413600		0,158	EPDM	100	Rubber gasket
FRK36	11216300		0,070	EPDM	250	Rubber gasket
FRK56	11216500		0,080	EPDM	10	Rubber gasket
FRK105	11216700		0,092	EPDM	225	Rubber gasket

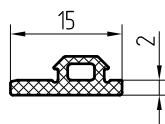
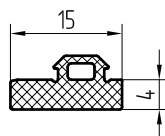
Gasket article	Code	Section	Weight, kg/m	Material	Qty in pack, m	Description
FRK124	11217100		0,621	EPDM	25	Rubber gasket
FRK125	11217200		0,494	EPDM	30	Rubber gasket
FRK137	11216900		0,183	EPDM	100	Rubber gasket
FRK138	11217000		0,043	EPDM	450	Rubber gasket
FRK150-01	11217600		0,187	EPDM	120	Rubber gasket
FRK161	11217800		0,075	EPDM	175	Rubber gasket
FRK126	11316500		0,033	EPDM	500	Rubber gasket
FRK127	11316600		0,055	EPDM	300	Rubber gasket
FRK128	11316700		0,095	EPDM	175	Rubber gasket

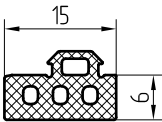
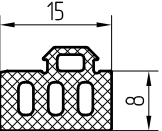
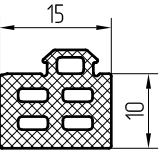
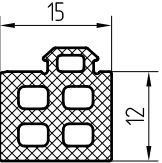
Gasket article	Code	Section	Weight, kg/m	Material	Qty in pack, m	Description
FRK129	11316800		0,118	EPDM	125	Rubber gasket
FRK130	11316900		0,142	EPDM	100	Rubber gasket
FRK131	11317000		0,179	EPDM	100	Rubber gasket
FRK132	11317100		0,194	EPDM	75	Rubber gasket



**ALUFACH ALTF50**  
CURTAIN WALL  
SYSTEM

PVC PROFILES  
(PVC-U-HI),  
PE (1:1).

05



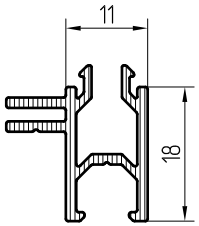
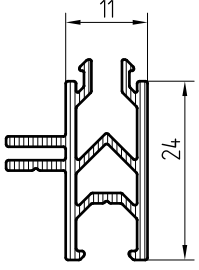
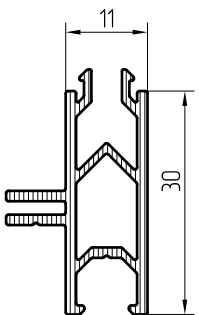
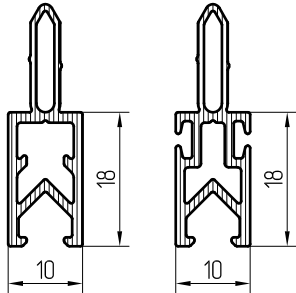

Article	Code	Section	Weight, kg/m	Material	Bar length, m	Qty in pack		Description
						bars	m	
AYPC.F50.0901	11210100		0,146	HPVC-U-HI	5,8	20	116	Distance profile
AYPC.F50.0902	11210200		0,187	HPVC-U-HI	5,8	20	116	Distance profile
AYPC.F50.0903	11210300		0,211	HPVC-U-HI	5,8	20	116	Distance profile
AYPC.F50.0905	11210500		0,152	HPVC-U-HI	5,8	20	116	Distance profile

Article	Code	Section	Weight, kg/m	Material	Bar length, m	Qty in pack		Description
						bars	m	
AYPC.F50.0906	11210600		0,183	HPVC-U-HI	5,8	20	116	Distance profile
AYPC.F50.0907	11210700		0,202	HPVC-U-HI	5,8	20	116	Distance profile
AYPC.F50.0915	11261100		0,219	HPVC-U-HI	5,8	20	116	Distance profile
AYPC.F50.0916	11261200		0,240	HPVC-U-HI	5,8	15	87	Distance profile

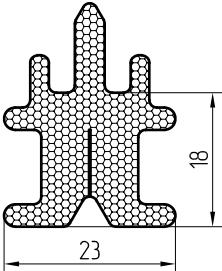
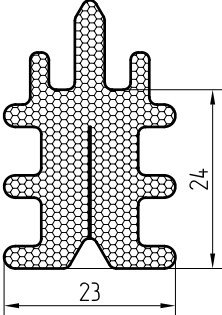
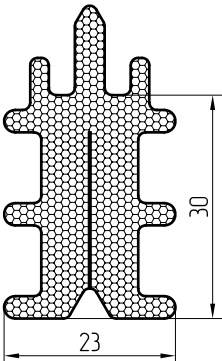
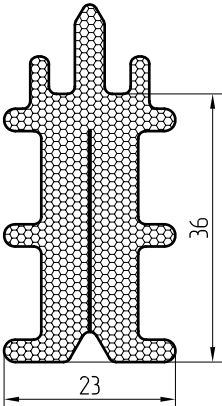
Article	Code	Section	Weight, kg/m	Material	Bar length, m	Qty in pack		Description
						bars	m	
AYPC.F50.0908	11211800		0,013	PE	2	240	480	Frame ledge sealing for glass unit
AYPC.F50.0909	11211900		0,016	PE	2	175	350	Frame ledge sealing for glass unit
AYPC.F50.0910	11210400		0,020	PE	2	140	280	Frame ledge sealing for glass unit
AYPC.F50.0911	11211400		0,022	PE	2	75	150	Frame ledge sealing for glass unit

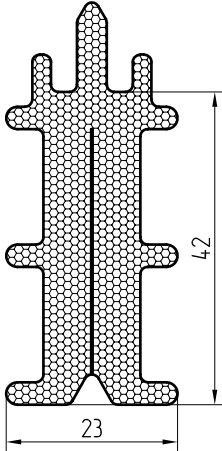
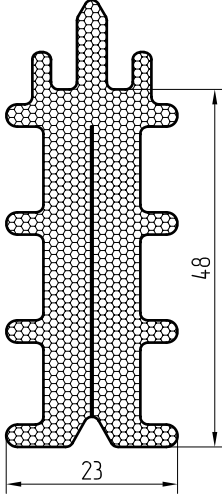
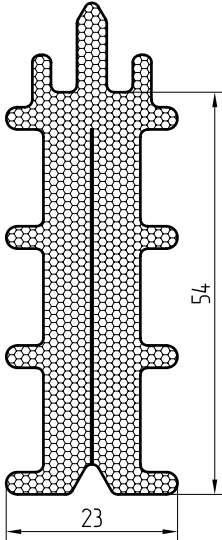
Article	Code	Section	Weight, kg/m	Material	Bar length, m	Qty in pack		Description
						bars	m	
AYPC.F50.0912	11211500		0,025	PE	2	70	140	Frame ledge sealing for glass unit
AYPC.F50.0913	11211600		0,029	PE	2	65	130	Frame ledge sealing for glass unit
AYPC.F50.0914	11211700		0,032	PE	2	60	120,0	Frame ledge sealing for glass unit



**ALUFACH ALTF50**  
CURTAIN WALL  
SYSTEM

## SYSTEM PROFILES (1:1)

06



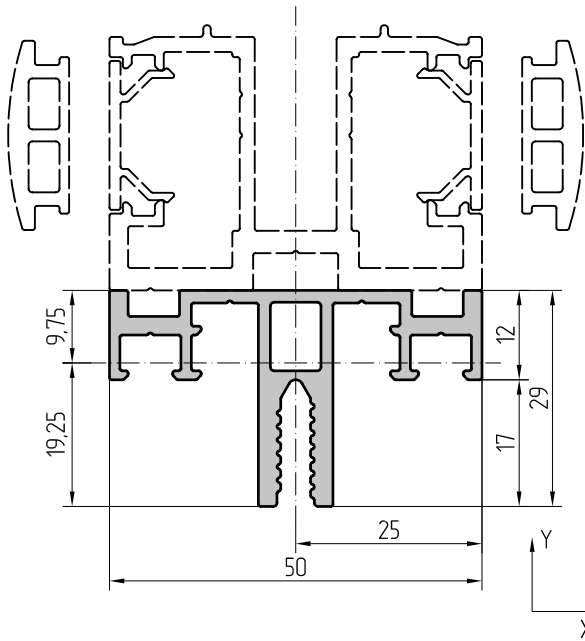

Scale 11		Mullion 12 mm	
AYPC.F50.0101	Article	Central moments of inertia	
0,853 kg	Theoretical weight 1 m	Jx=2,09 cm <sup>4</sup>	Jy=5,50 cm <sup>4</sup>
285,6 mm	External perimeter	Moments of resistance	
3,148 cm <sup>2</sup>	Cross section area	Wx=1,08 cm <sup>3</sup>	Wy=2,20 cm <sup>3</sup>
		Radius of inertia	
		ix=0,81 cm	iy=1,32 cm

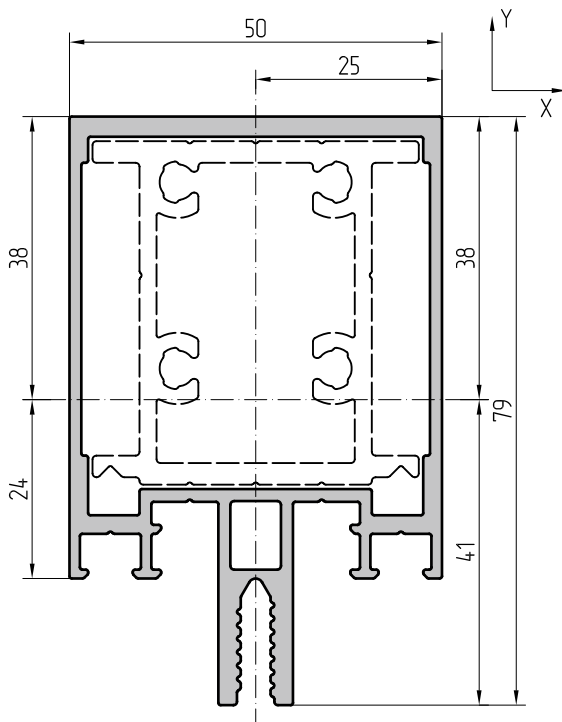

Scale 11		Mullion 62 mm	
AYPC.F50.0102	Article	Central moments of inertia	
1,668 kg	Theoretical weight 1 m	Jx=40,79 cm <sup>4</sup>	Jy=17,94 cm <sup>4</sup>
372,6 mm	External perimeter	Moments of resistance	
6,156 cm <sup>2</sup>	Cross section area	Wx=9,95 cm <sup>3</sup>	Wy=7,18 cm <sup>3</sup>
		Radius of inertia	
		ix=2,57 cm	iy=1,71 cm

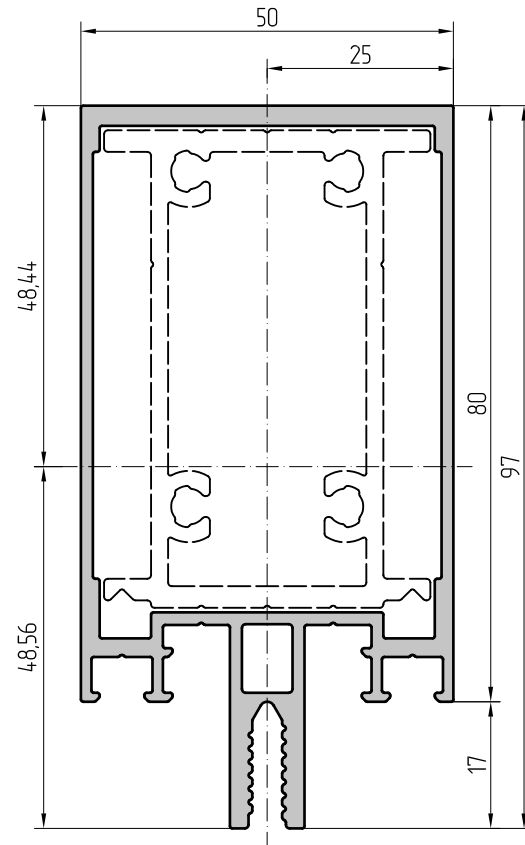

Scale 11		Mullion 80 mm	
AYPC.F50.0103	Article	Central moments of inertia	
1,824 kg	Theoretical weight 1 m	Jx=71,55 cm <sup>4</sup>	Jy=21,32 cm <sup>4</sup>
408,6 mm	External perimeter	Moments of resistance	
6,732 cm <sup>2</sup>	Cross section area	Wx=14,73 cm <sup>3</sup>	Wy=8,53 cm <sup>3</sup>
		Radius of inertia	
		ix=3,26 cm	iy=1,78 cm

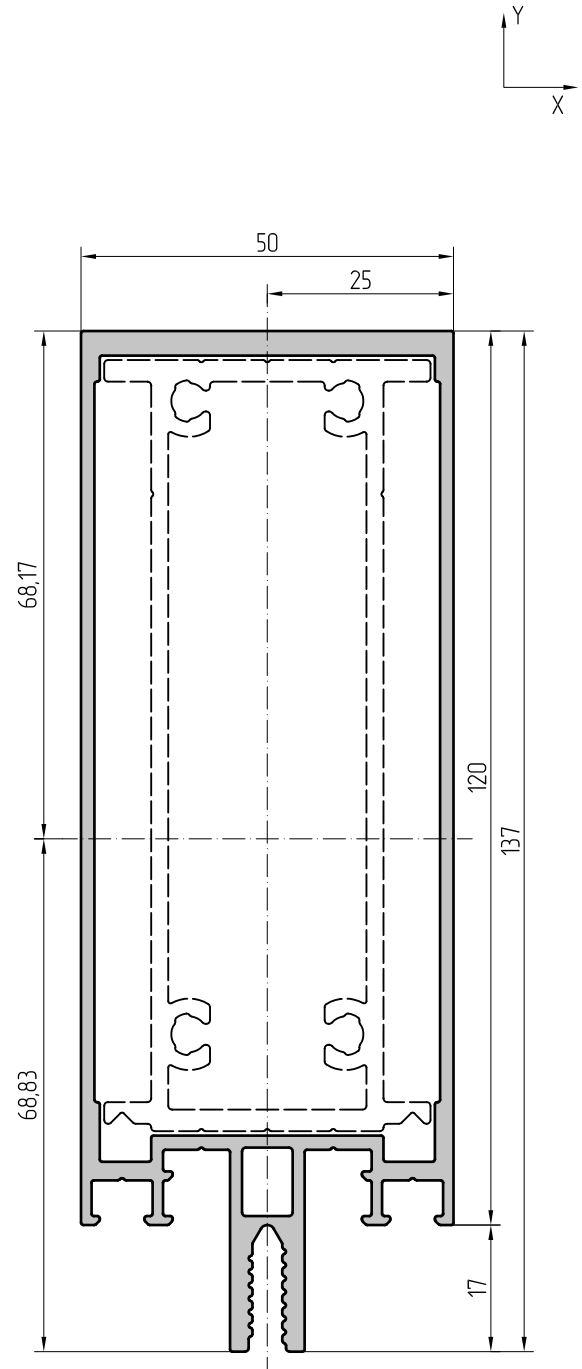
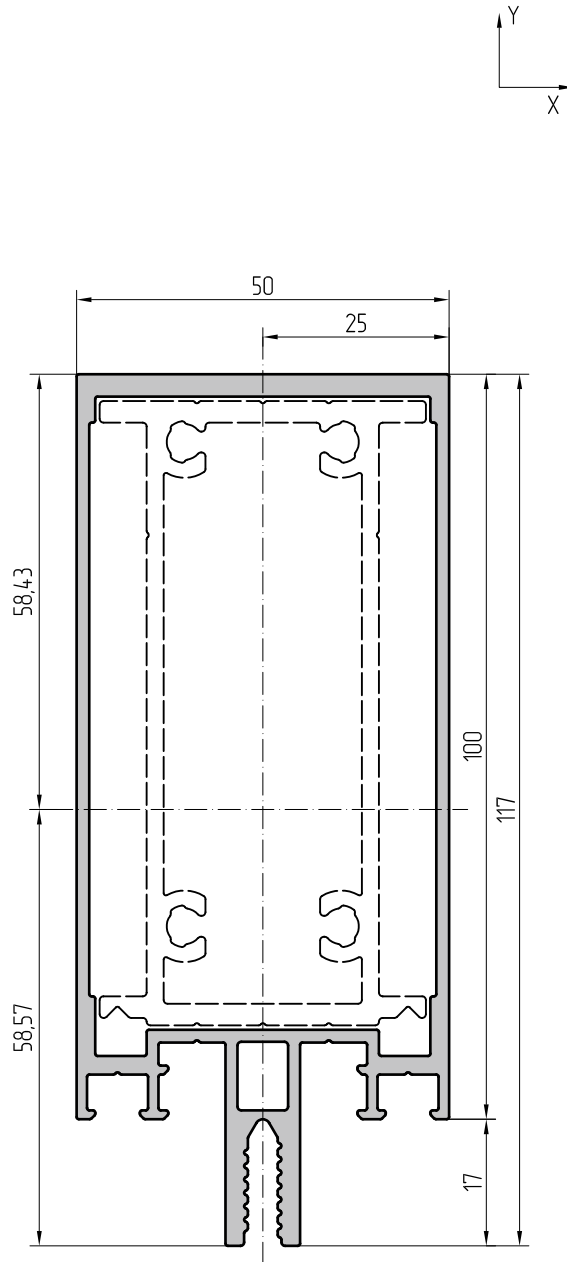

Scale 1:1	Mullion 100 mm		Scale 1:1	Mullion 120 mm	
AYPC.F50.0104	Article	Central moments of inertia	AYPC.F50.0105	Article	Central moments of inertia
2,078 kg	Theoretical weight 1 m	$J_x=123,79 \text{ cm}^4$   $J_y=26,16 \text{ cm}^4$	2,362 kg	Theoretical weight 1 m	$J_x=196,33 \text{ cm}^4$   $J_y=31,46 \text{ cm}^4$
450,5 mm	External perimeter	Moments of resistance	487,8 mm	External perimeter	Moments of resistance
7,667 cm <sup>2</sup>	Cross section area	$W_x=21,13 \text{ cm}^3$   $W_y=10,46 \text{ cm}^3$	8,716 cm <sup>2</sup>	Cross section area	$W_x=28,52 \text{ cm}^3$   $W_y=12,58 \text{ cm}^3$
		Radius of inertia			Radius of inertia
		$i_x=4,02 \text{ cm}$   $i_y=1,85 \text{ cm}$			$i_x=4,75 \text{ cm}$   $i_y=1,90 \text{ cm}$



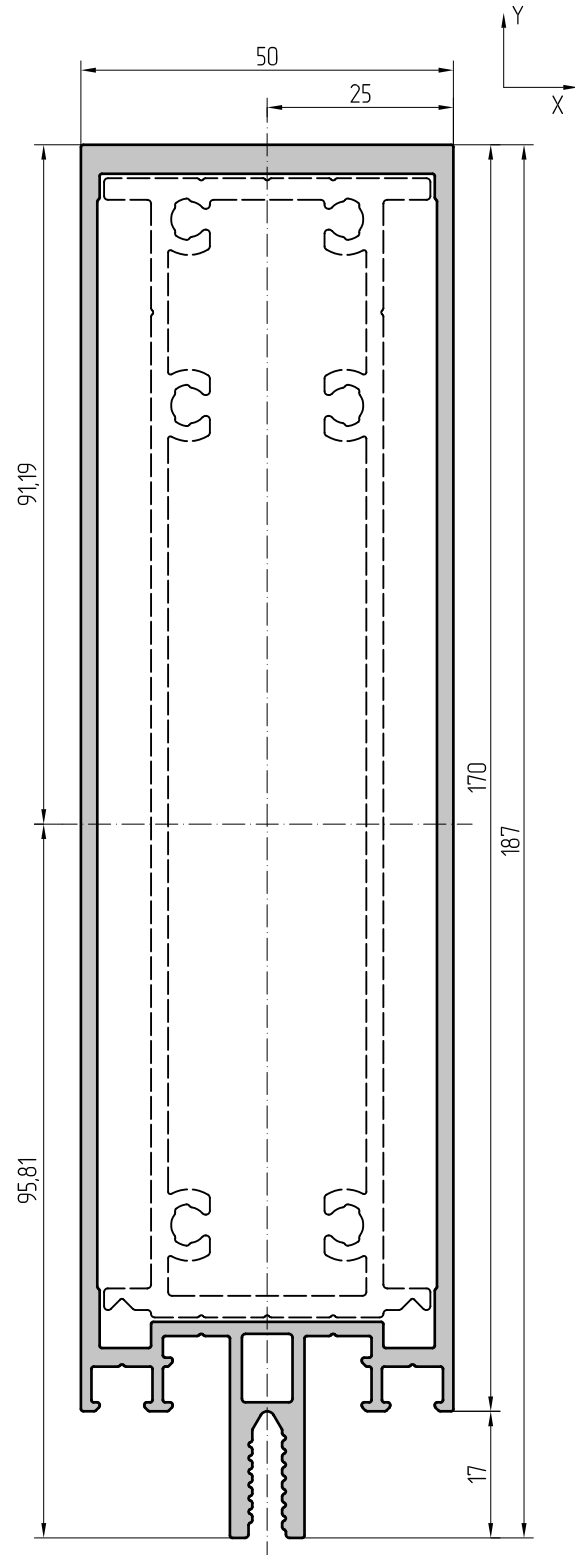
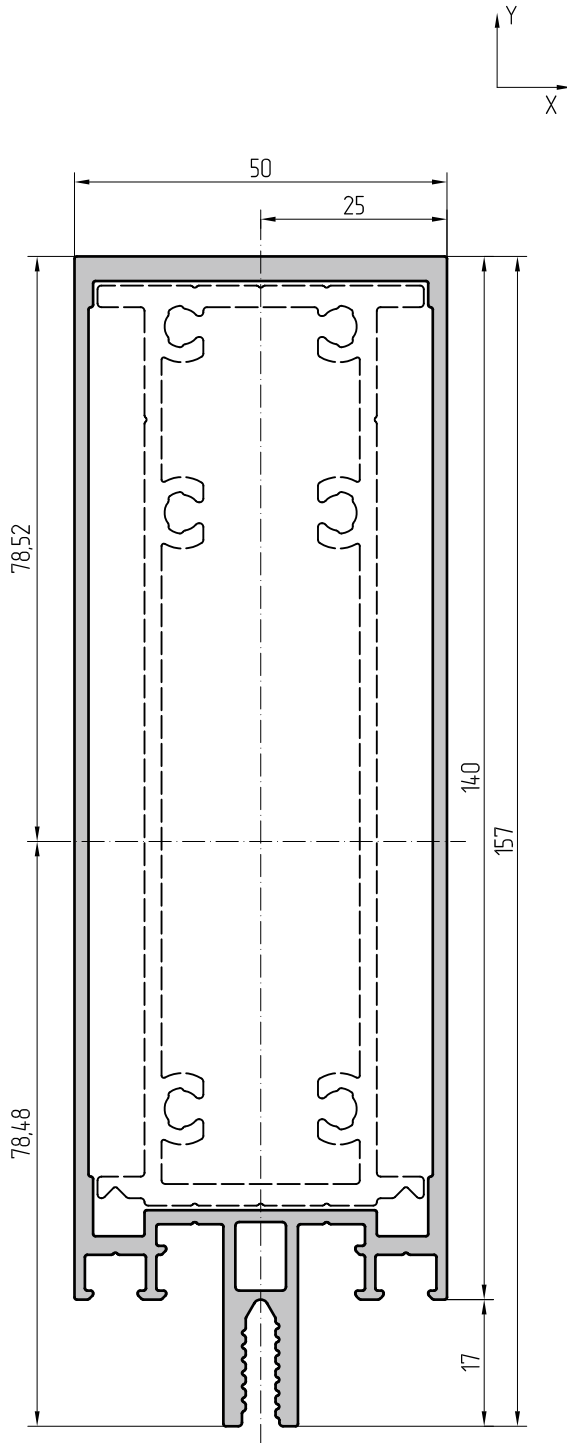

Scale 1:1		Mullion 140 mm		Scale 1:1		Mullion 170 mm	
AYPC.F50.0106	Article	Central moments of inertia		AYPC.F50.0107	Article	Central moments of inertia	
2,620 kg	Theoretical weight 1 m	$J_x=283,75 \text{ cm}^4$	$J_y=36,90 \text{ cm}^4$	3,230 kg	Theoretical weight 1 m	$J_x=487,60 \text{ cm}^4$	$J_y=48,60 \text{ cm}^4$
527,8 mm	External perimeter	Moments of resistance		587,8 mm	External perimeter	Moments of resistance	
9,669 cm <sup>2</sup>	Cross section area	$W_x=36,14 \text{ cm}^3$	$W_y=14,76 \text{ cm}^3$	11,963 cm <sup>2</sup>	Cross section area	$W_x=53,47 \text{ cm}^3$	$W_y=19,44 \text{ cm}^3$
		Radius of inertia				Radius of inertia	
		$i_x=5,42 \text{ cm}$	$i_y=1,95 \text{ cm}$			$i_x=6,38 \text{ cm}$	$i_y=2,01 \text{ cm}$

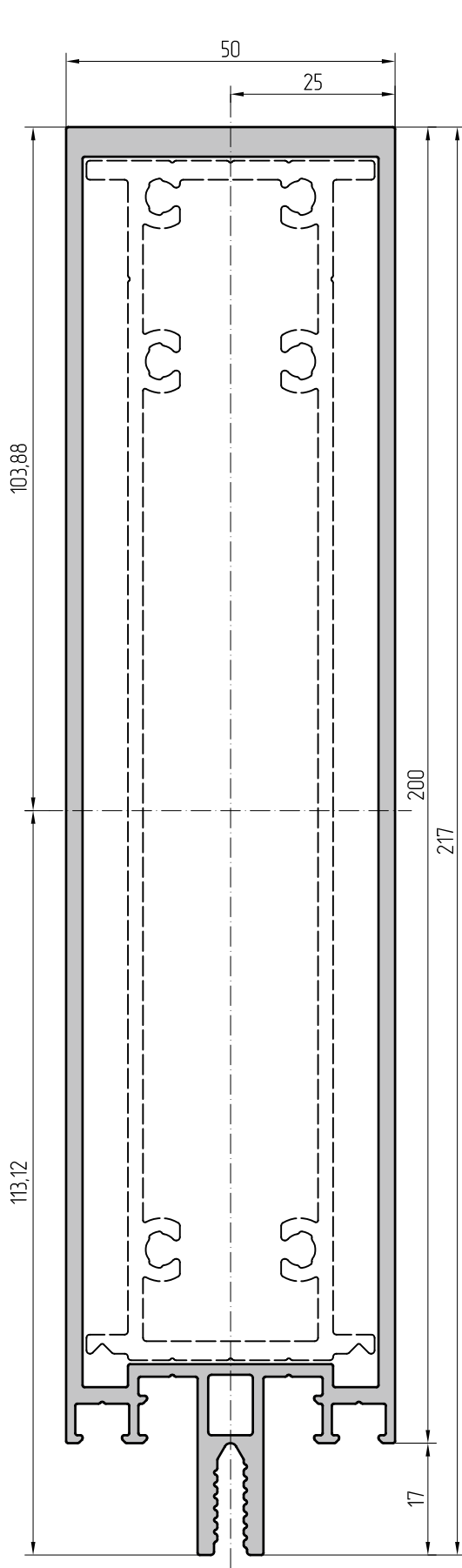

Scale 1:1		Mullion 200 mm	
AYPC.F50.0108	Article	Central moments of inertia	
3,945 kg	Theoretical weight 1 m	$J_x=777,44 \text{ cm}^4$	$J_y=62,03 \text{ cm}^4$
64,78 mm	External perimeter	Moments of resistance	
14,601 cm <sup>2</sup>	Cross section area	$W_x=68,73 \text{ cm}^3$	$W_y=24,81 \text{ cm}^3$
		Radius of inertia	
		$i_x=7,29 \text{ cm}$	$i_y=2,06 \text{ cm}$

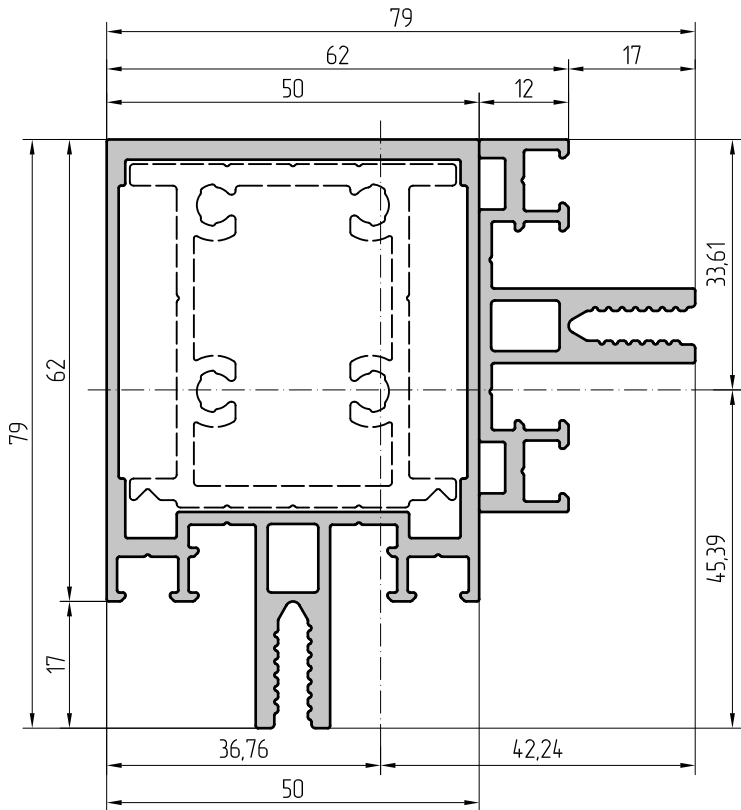

Scale 1:1	Mullions 12 mm and 62 mm for 90° angle
AYPC.F50.0101	Article
AYPC.F50.0102	Article
2,521 kg	Theoretical weight 1 m
658,2 mm	External perimeter
9,304 cm <sup>2</sup>	Cross section area
Central moments of inertia	
Jx=49,32 cm <sup>4</sup>	Jy=45,19 cm <sup>4</sup>
Moments of resistance	
Wx=10,86 cm <sup>3</sup>	Wy=10,70 cm <sup>3</sup>
Radius of inertia	
ix=2,31 cm	iy=2,20 cm

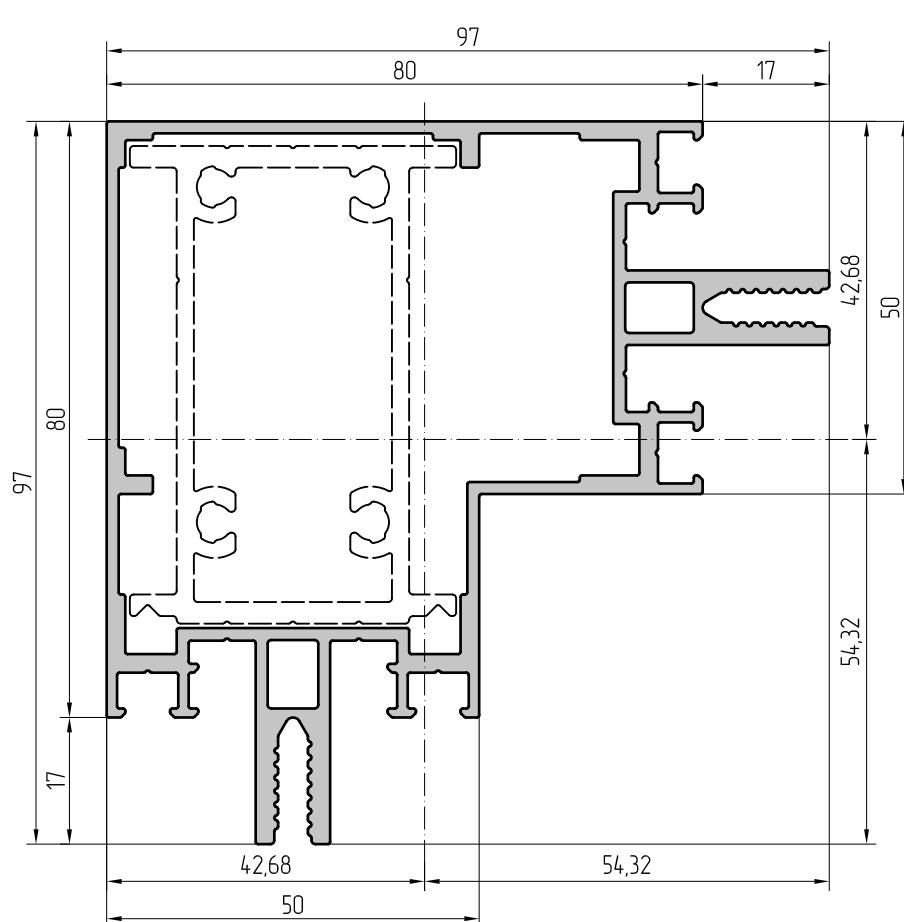

Scale 1:1	Mullion 80 mm for 90° angle
AYPC.F50.0109	Article
2,597 kg	Theoretical weight 1 m
617,4 mm	External perimeter
9,583 cm <sup>2</sup>	Cross section area
Central moments of inertia	
Jx=85,41 cm <sup>4</sup>	Jy=85,41 cm <sup>4</sup>
Moments of resistance	
Wx=15,72 cm <sup>3</sup>	Wy=15,72 cm <sup>3</sup>
Radius of inertia	
ix=2,98 cm	iy=2,98 cm

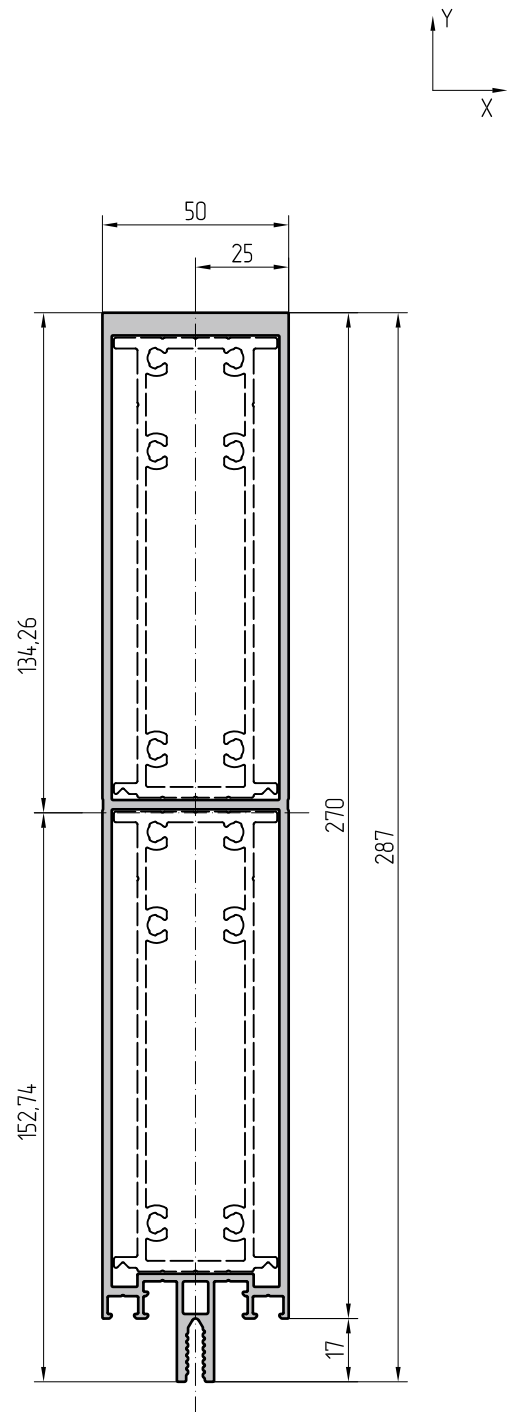
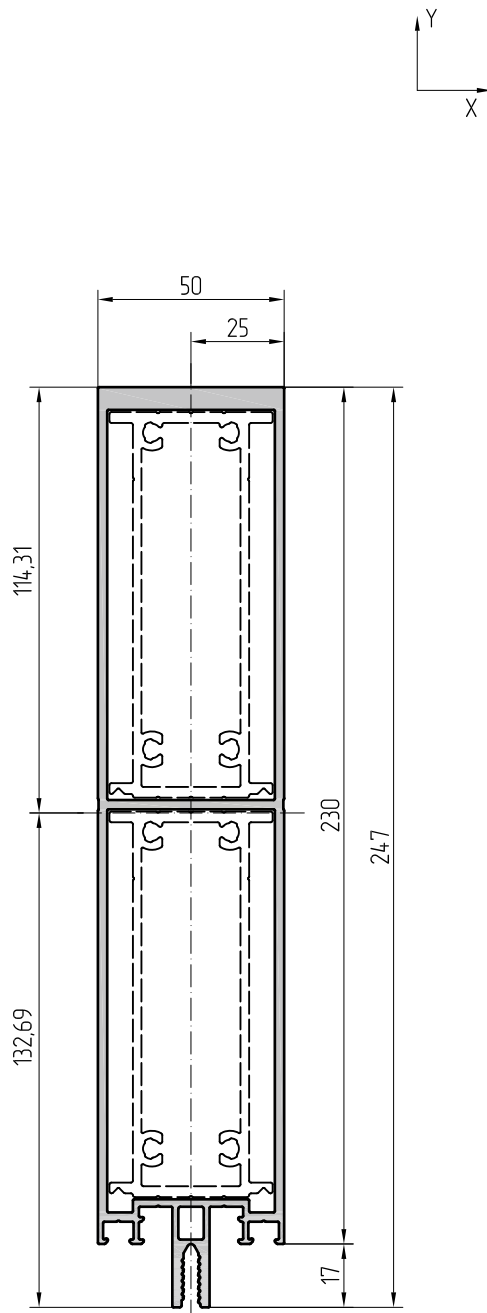

Scale 12 Mullion 230 mm			Scale 12 Mullion 270 mm		
AYPC.F50.0110	Article	Central moments of inertia	AYPC.F50.0111	Article	Central moments of inertia
4,857 kg	Theoretical weight 1 m	$J_x=1191,04 \text{ cm}^4$   $J_y=73,56 \text{ cm}^4$	5,397 kg	Theoretical weight 1 m	$J_x=1767,87 \text{ cm}^4$   $J_y=84,85 \text{ cm}^4$
707,6 mm	External perimeter	Moments of resistance	787,6 mm	External perimeter	Moments of resistance
17,989 cm <sup>2</sup>	Cross section area	$W_x=89,98 \text{ cm}^3$   $W_y=29,42 \text{ cm}^3$	19,989 cm <sup>2</sup>	Cross section area	$W_x=115,58 \text{ cm}^3$   $W_y=33,94 \text{ cm}^3$
		Radius of inertia			Radius of inertia
		$i_x=8,14 \text{ cm}$   $i_y=2,02 \text{ cm}$			$i_x=9,40 \text{ cm}$   $i_y=2,06 \text{ cm}$

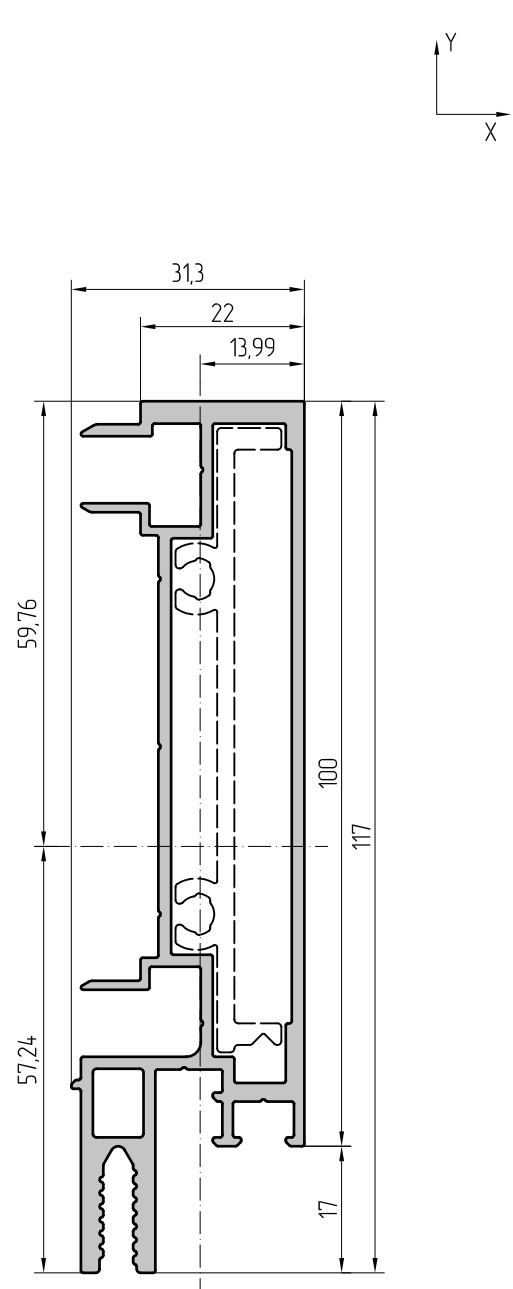
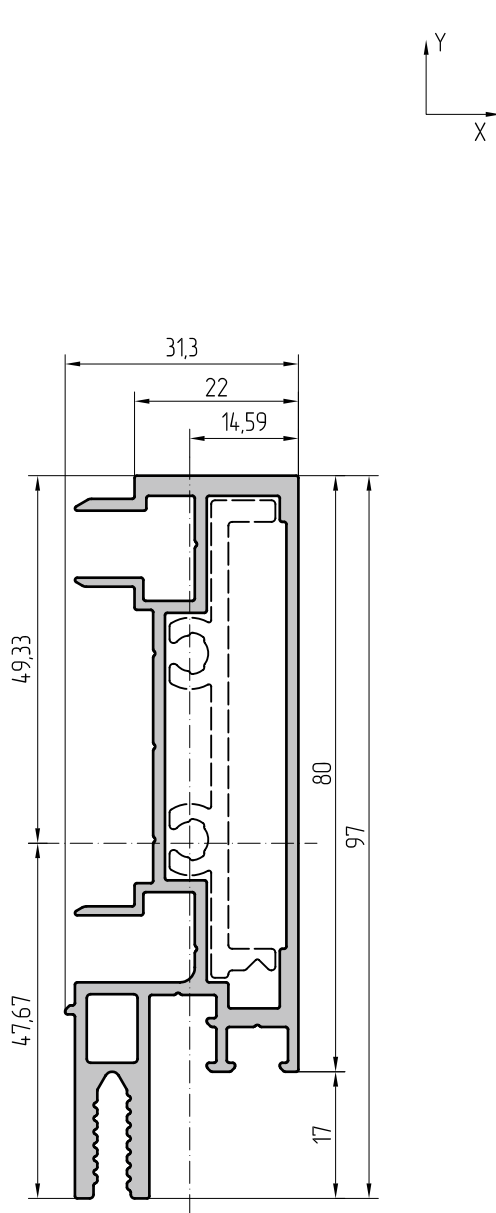

Scale 1:1		Mullion 80 mm		Scale 1:1		Mullion 100 mm	
AYPC.F50.0113	Article	Central moments of inertia		AYPC.F50.0114	Article	Central moments of inertia	
1,566 kg	Theoretical weight 1 m	Jx=55,16 cm <sup>4</sup>	Jy=5,58 cm <sup>4</sup>	1,789 kg	Theoretical weight 1 m	Jx=95,37 cm <sup>4</sup>	Jy=6,39 cm <sup>4</sup>
428,5 mm	External perimeter	Moments of resistance		467,7 mm	External perimeter	Moments of resistance	
5,777 cm <sup>2</sup>	Cross section area	Wx=11,18 cm <sup>3</sup>	Wy=3,34 cm <sup>3</sup>	6,602 cm <sup>2</sup>	Cross section area	Wx=15,96 cm <sup>3</sup>	Wy=3,69 cm <sup>3</sup>
		Radius of inertia				Radius of inertia	
		ix=3,09 cm	iy=0,98 cm			ix=3,80 cm	iy=0,98 cm

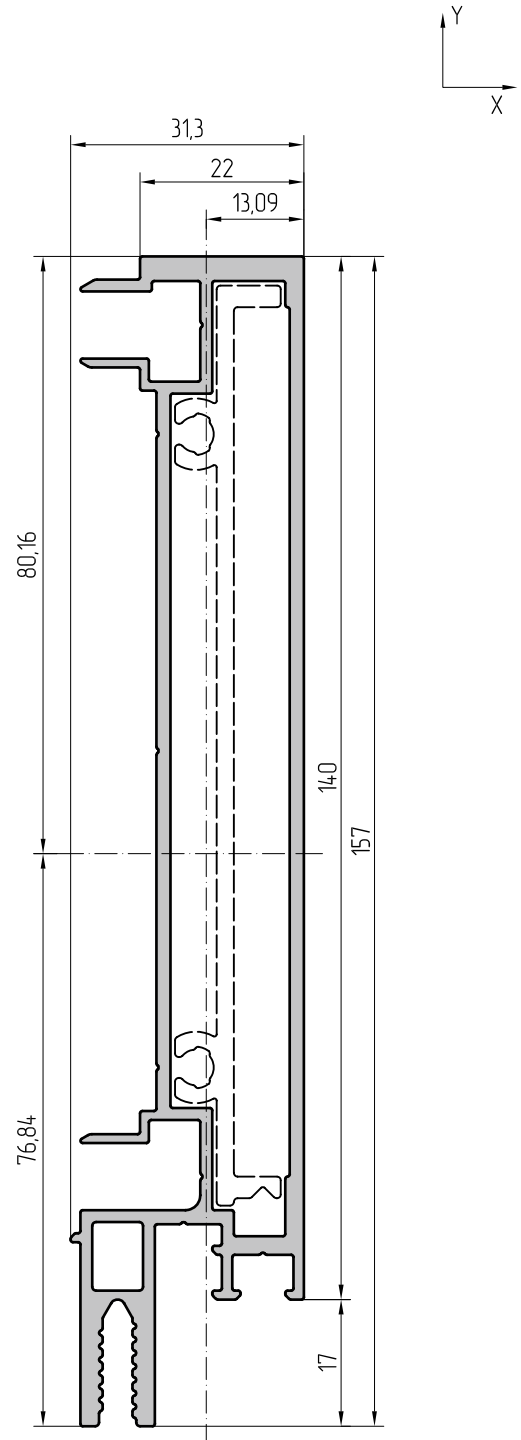
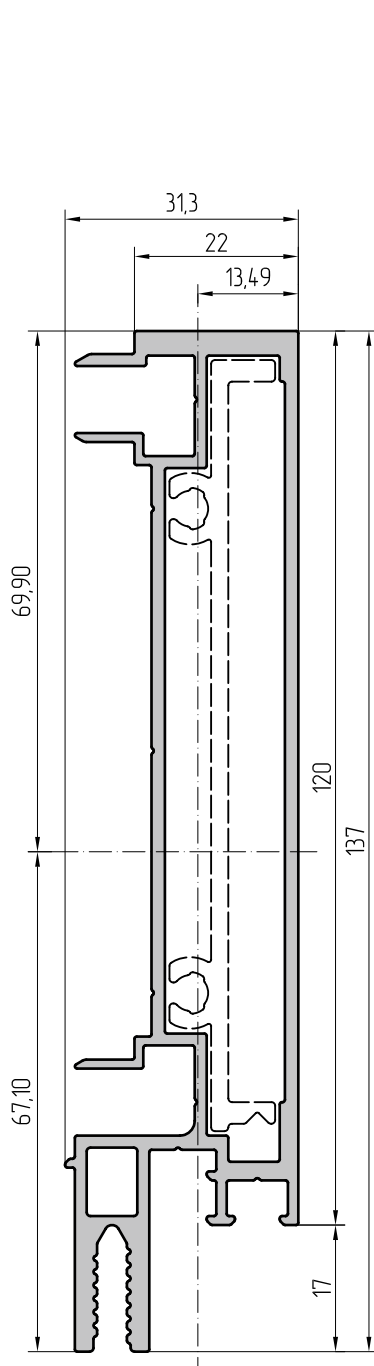

Scale 1:1		Mullion 120 mm		Scale 1:1		Mullion 140 mm	
AYPC.F50.0115	Article	Central moments of inertia		AYPC.F50.0116	Article	Central moments of inertia	
2,039 kg	Theoretical weight 1 m	$J_x=151,34 \text{ cm}^4$	$J_y=7,23 \text{ cm}^4$	2,292 kg	Theoretical weight 1 m	$J_x=222,26 \text{ cm}^4$	$J_y=8,08 \text{ cm}^4$
506,5 mm	External perimeter	Moments of resistance		546,3 mm	External perimeter	Moments of resistance	
7,525 cm <sup>2</sup>	Cross section area	$W_x=21,65 \text{ cm}^3$	$W_y=4,06 \text{ cm}^3$	8,458 cm <sup>2</sup>	Cross section area	$W_x=27,73 \text{ cm}^3$	$W_y=4,44 \text{ cm}^3$
		Radius of inertia				Radius of inertia	
		$i_x=4,48 \text{ cm}$	$i_y=0,98 \text{ cm}$			$i_x=5,13 \text{ cm}$	$i_y=0,97 \text{ cm}$

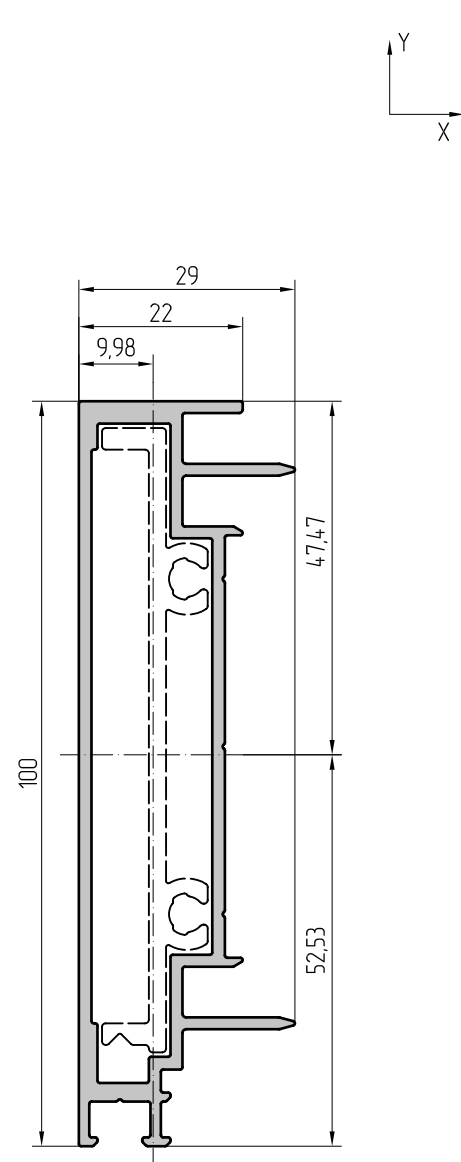
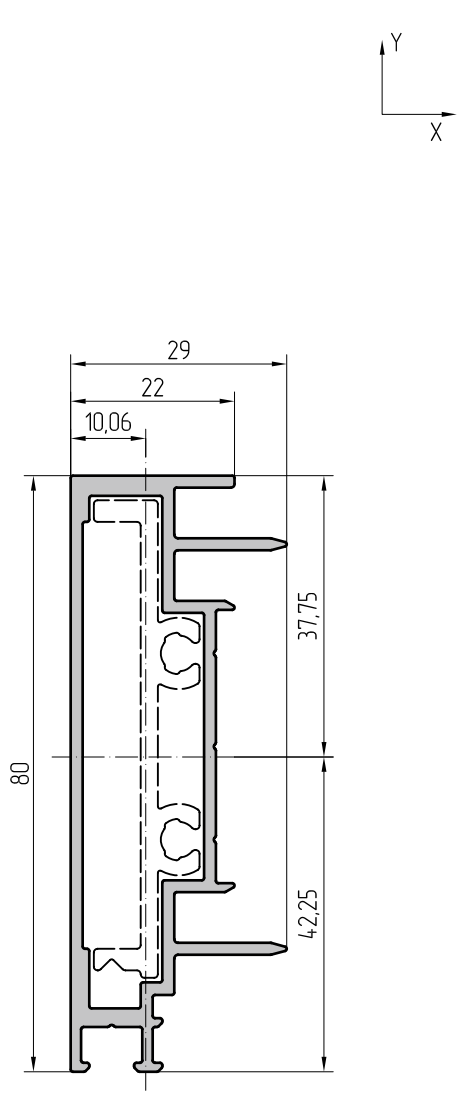

Scale 1:1		Mullion 80 mm		Scale 1:1		Mullion 100 mm	
AYPC.F50.0123	Article	Central moments of inertia		AYPC.F50.0124	Article	Central moments of inertia	
1,094 kg	Theoretical weight 1 m	$J_x=27,87 \text{ cm}^4$	$J_y=2,61 \text{ cm}^4$	1,314 kg	Theoretical weight 1 m	$J_x=52,51 \text{ cm}^4$	$J_y=3,24 \text{ cm}^4$
299,1 mm	External perimeter	Moments of resistance		339,6 mm	External perimeter	Moments of resistance	
4,037 cm <sup>2</sup>	Cross section area	$W_x=6,50 \text{ cm}^3$	$W_y=1,38 \text{ cm}^3$	4,849 cm <sup>2</sup>	Cross section area	$W_x=10,00 \text{ cm}^3$	$W_y=1,70 \text{ cm}^3$
		Radius of inertia				Radius of inertia	
		$i_x=2,63 \text{ cm}$	$i_y=0,80 \text{ cm}$			$i_x=3,29 \text{ cm}$	$i_y=0,82 \text{ cm}$

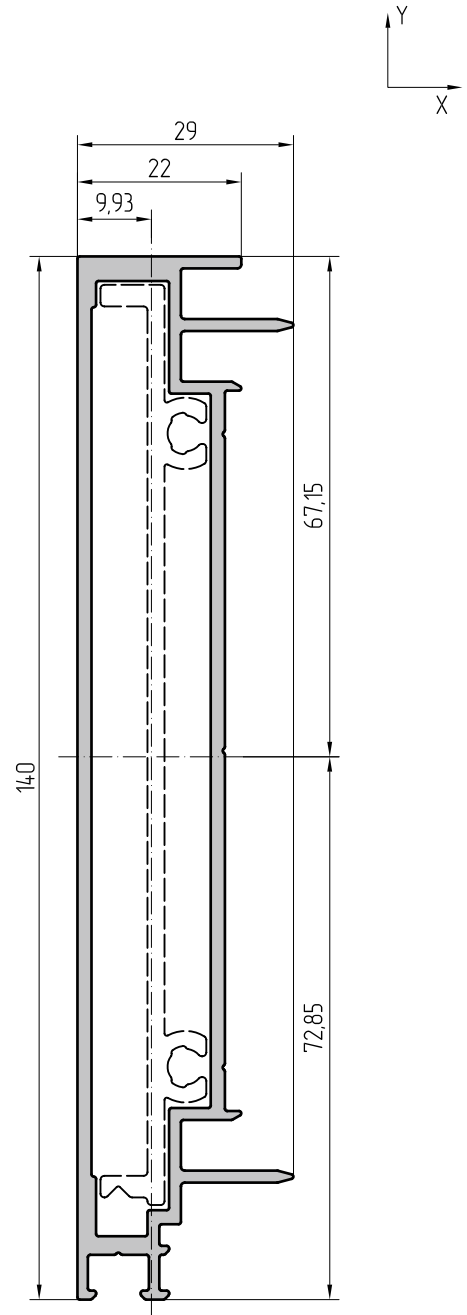
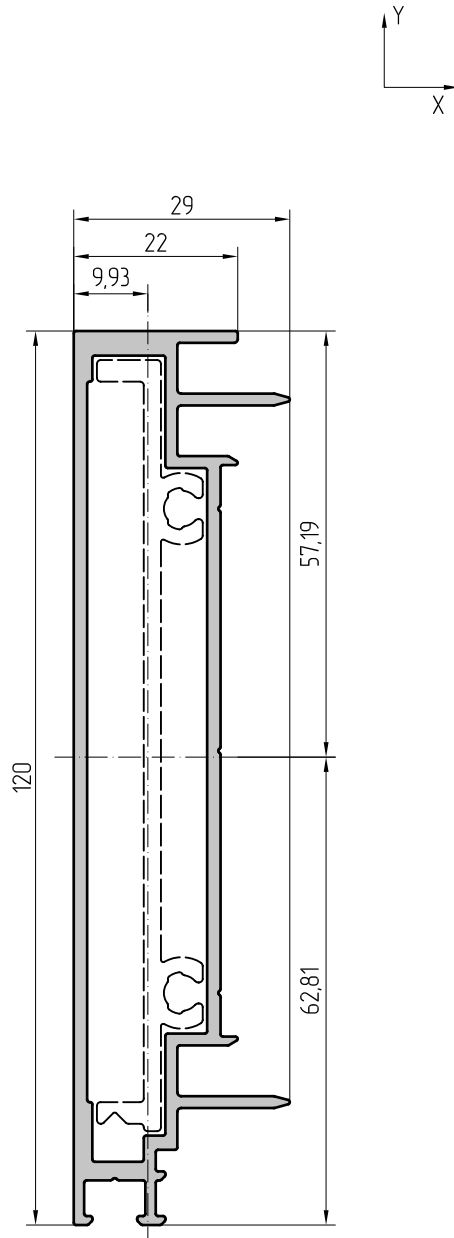

Scale 1:1	Mullion 120 mm			Scale 1:1	Mullion 140 mm		
AYPC.F50.0125	Article	Central moments of inertia		AYPC.F50.0126	Article	Central moments of inertia	
1,555 kg	Theoretical weight 1 m	Jx=88,47 cm <sup>4</sup>	Jy=3,93 cm <sup>4</sup>	1,807 kg	Theoretical weight 1 m	Jx=136,73 cm <sup>4</sup>	Jy=4,68 cm <sup>4</sup>
379,5 mm	External perimeter	Moments of resistance		418,4 mm	External perimeter	Moments of resistance	
5,740 cm <sup>2</sup>	Cross section area	Wx=14,08 cm <sup>3</sup>	Wy=2,06 cm <sup>3</sup>	6,668 cm <sup>2</sup>	Cross section area	Wx=18,77 cm <sup>3</sup>	Wy=2,45 cm <sup>3</sup>
		Radius of inertia				Radius of inertia	
		ix=3,93 cm	iy=0,83 cm			ix=4,53 cm	iy=0,84 cm



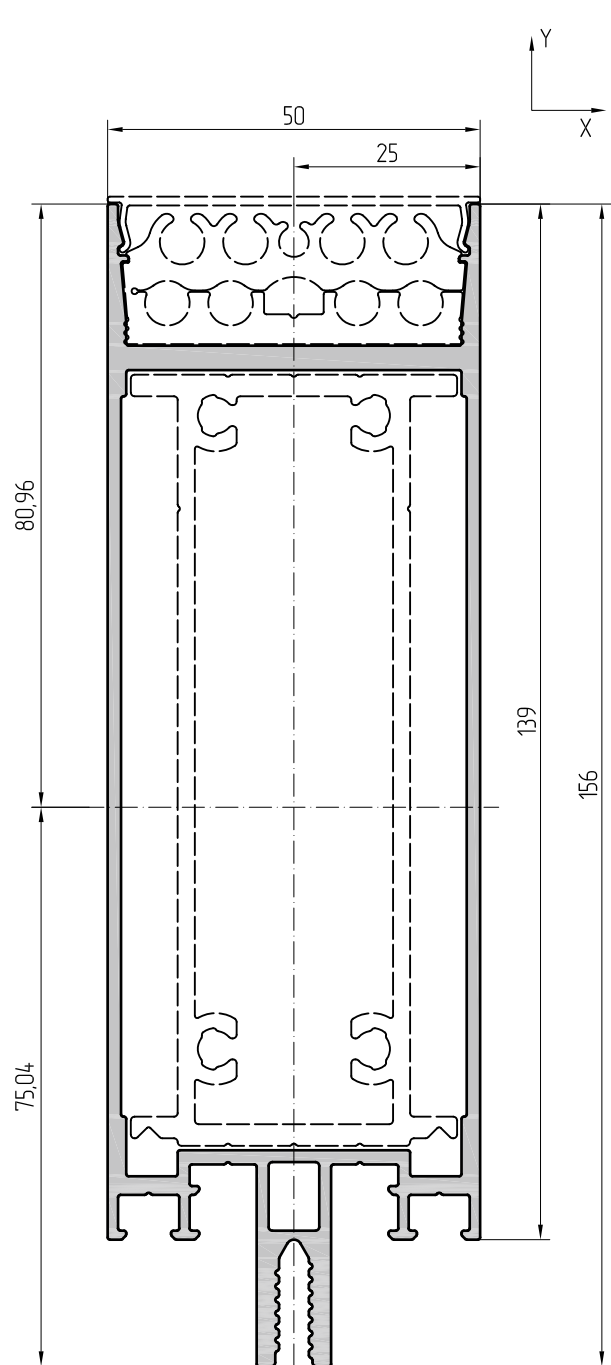
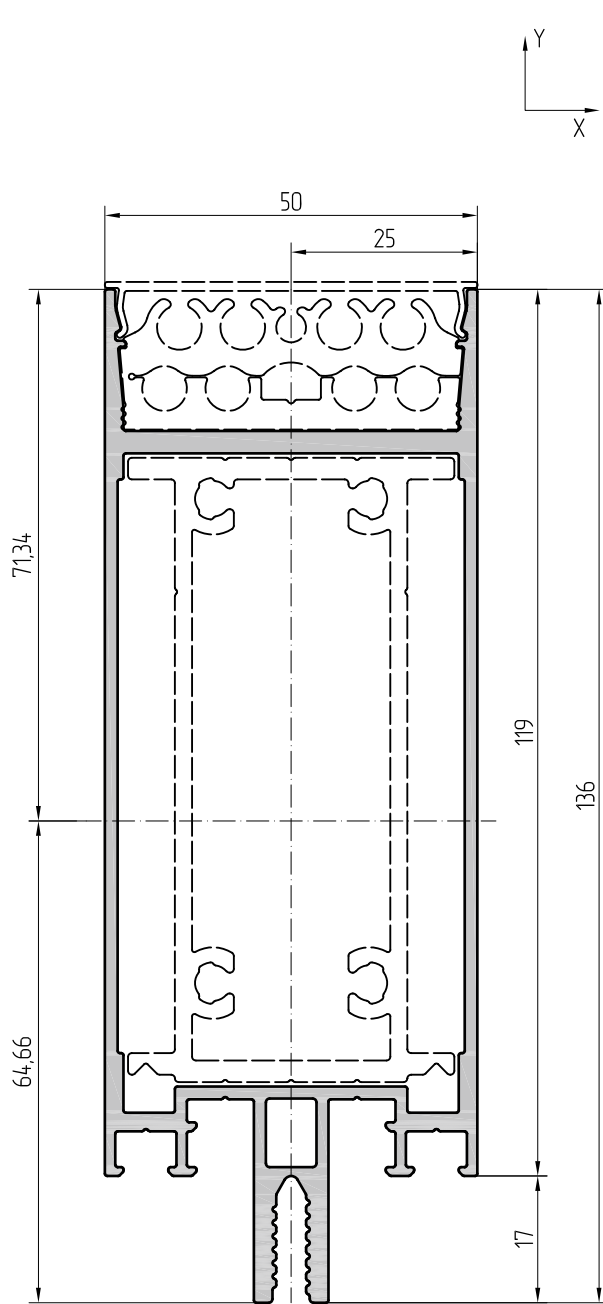

Scale 1:1 Mullion 120 mm		Scale 1:1 Mullion 140 mm	
AYPC.F50.0145	Article	AYPC.F50.0146	Article
2,280 kg	Theoretical weight 1 m	2,560 kg	Theoretical weight 1 m
526,7 mm	External perimeter	565,9 mm	External perimeter
8,433 cm <sup>2</sup>	Cross section area	9,482 cm <sup>2</sup>	Cross section area
	Central moments of inertia		Central moments of inertia
	Jx=155,3 cm <sup>4</sup>   Jy=30,6 cm <sup>4</sup>		Jx=238,1 cm <sup>4</sup>   Jy=35,9 cm <sup>4</sup>
	Moments of resistance		Moments of resistance
	Wx=21,77 cm <sup>3</sup>   Wy=12,24 cm <sup>3</sup>		Wx=29,41 cm <sup>3</sup>   Wy=14,36 cm <sup>3</sup>
	Radius of inertia		Radius of inertia
	ix=4,29 cm   iy=1,9 cm		ix=5,01 cm   iy=1,94 cm

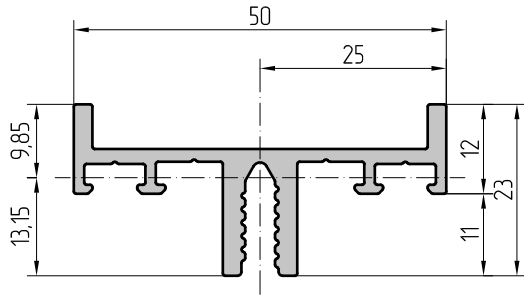

Scale 1:1		Transom 12 mm	
AYPC.F50.0201	Article	Central moments of inertia	
0,654 kg	Theoretical weight 1 m	$J_x=0,65 \text{ cm}^4$	$J_y=4,95 \text{ cm}^4$
231,9 mm	External perimeter	Moments of resistance	
2,413 cm <sup>2</sup>	Cross section area	$W_x=0,49 \text{ cm}^3$	$W_y=1,98 \text{ cm}^3$
		Radius of inertia	
		$i_x=0,52 \text{ cm}$	$i_y=1,43 \text{ cm}$

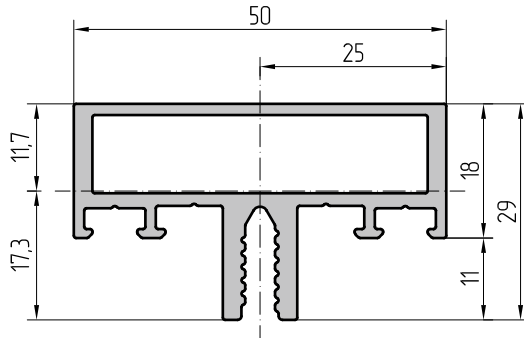

Scale 1:1		Transom 18 mm	
AYPC.F50.0202	Article	Central moments of inertia	
0,918 kg	Theoretical weight 1 m	$J_x=2,11 \text{ cm}^4$	$J_y=7,79 \text{ cm}^4$
232,4 mm	External perimeter	Moments of resistance	
3,389 cm <sup>2</sup>	Cross section area	$W_x=1,22 \text{ cm}^3$	$W_y=3,12 \text{ cm}^3$
		Radius of inertia	
		$i_x=0,79 \text{ cm}$	$i_y=1,52 \text{ cm}$

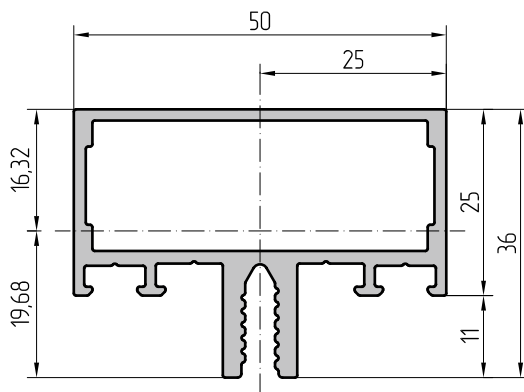

Scale 1:1		Transom 25 mm	
AYPC.F50.0203	Article	Central moments of inertia	
0,962 kg	Theoretical weight 1 m	$J_x=3,95 \text{ cm}^4$	$J_y=8,77 \text{ cm}^4$
246,4 mm	External perimeter	Moments of resistance	
3,550 cm <sup>2</sup>	Cross section area	$W_x=2,01 \text{ cm}^3$	$W_y=3,51 \text{ cm}^3$
		Radius of inertia	
		$i_x=1,05 \text{ cm}$	$i_y=1,57 \text{ cm}$

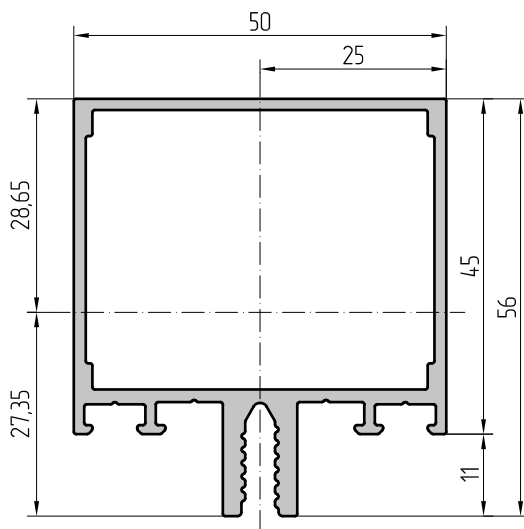

Scale 1:1		Transom 45 mm	
AYPC.F50.0204	Article	Central moments of inertia	
1,131 kg	Theoretical weight 1 m	$J_x=13,89 \text{ cm}^4$	$J_y=12,52 \text{ cm}^4$
286,4 mm	External perimeter	Moments of resistance	
4,190 cm <sup>2</sup>	Cross section area	$W_x=4,85 \text{ cm}^3$	$W_y=5,01 \text{ cm}^3$
		Radius of inertia	
		$i_x=1,90 \text{ cm}$	$i_y=1,73 \text{ cm}$

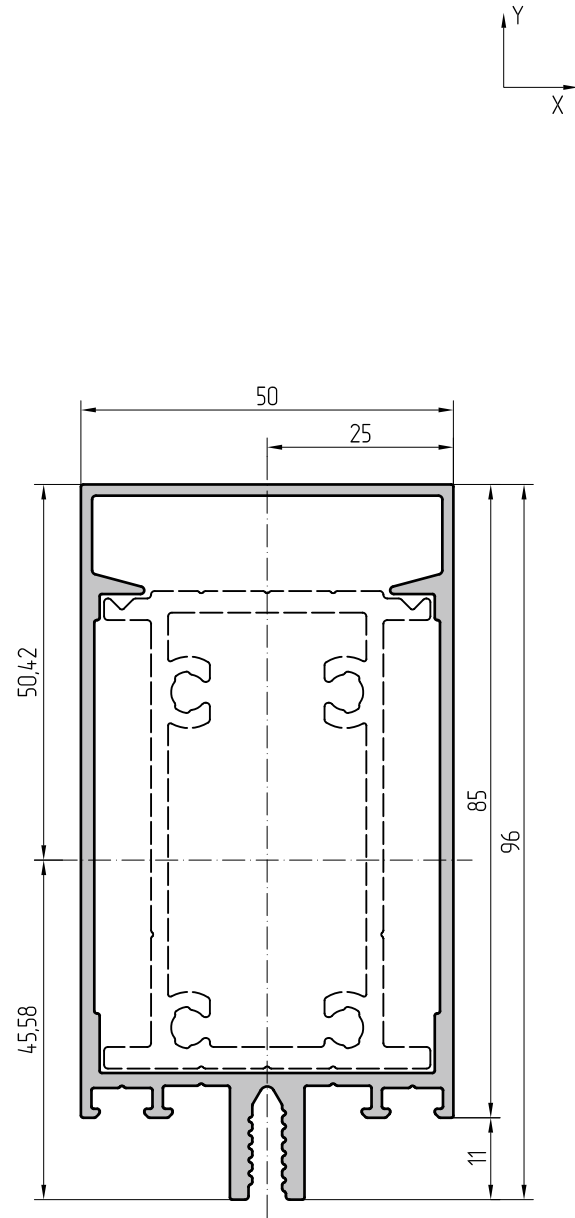
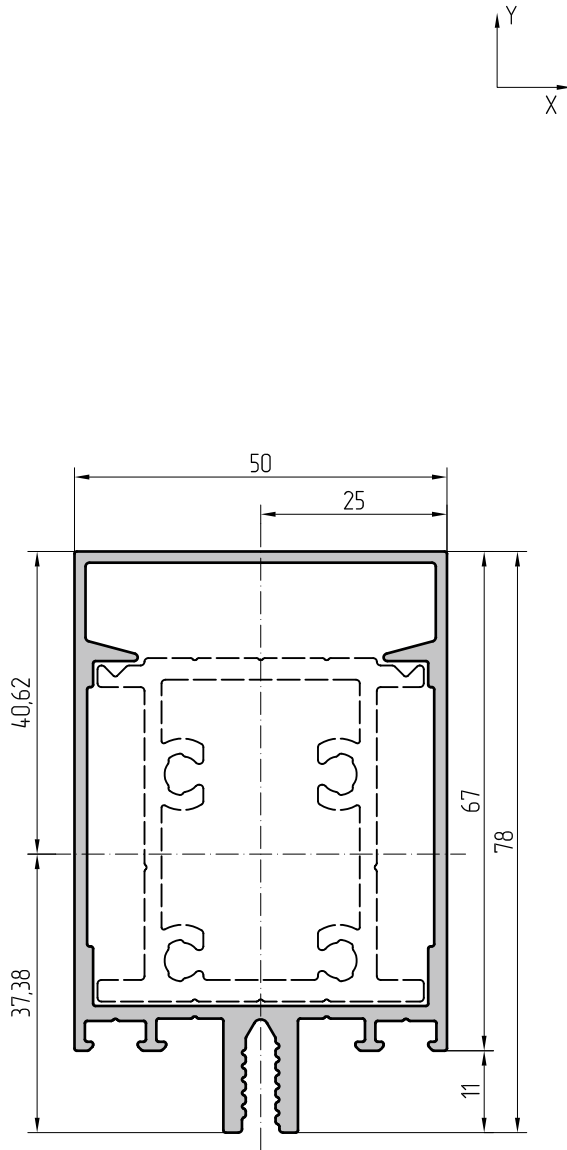

Scale 1:1	Transom 67 mm			Scale 1:1	Transom 85 mm		
AYPC.F50.0205	Article	Central moments of inertia		AYPC.F50.0206	Article	Central moments of inertia	
1,424 kg	Theoretical weight 1 m	Jx=35,53 cm <sup>4</sup>	Jy=18,40 cm <sup>4</sup>	1,617 kg	Theoretical weight 1 m	Jx=62,67 cm <sup>4</sup>	Jy=22,54 cm <sup>4</sup>
330,4 mm	External perimeter	Moments of resistance		366,4 mm	External perimeter	Moments of resistance	
5,273 cm <sup>2</sup>	Cross section area	Wx=8,75 cm <sup>3</sup>	Wy=7,36 cm <sup>3</sup>	5,990 cm <sup>2</sup>	Cross section area	Wx=12,43 cm <sup>3</sup>	Wy=9,02 cm <sup>3</sup>
		Radius of inertia				Radius of inertia	
		ix=2,59 cm	iy=1,87 cm			ix=3,23 cm	iy=1,94 cm

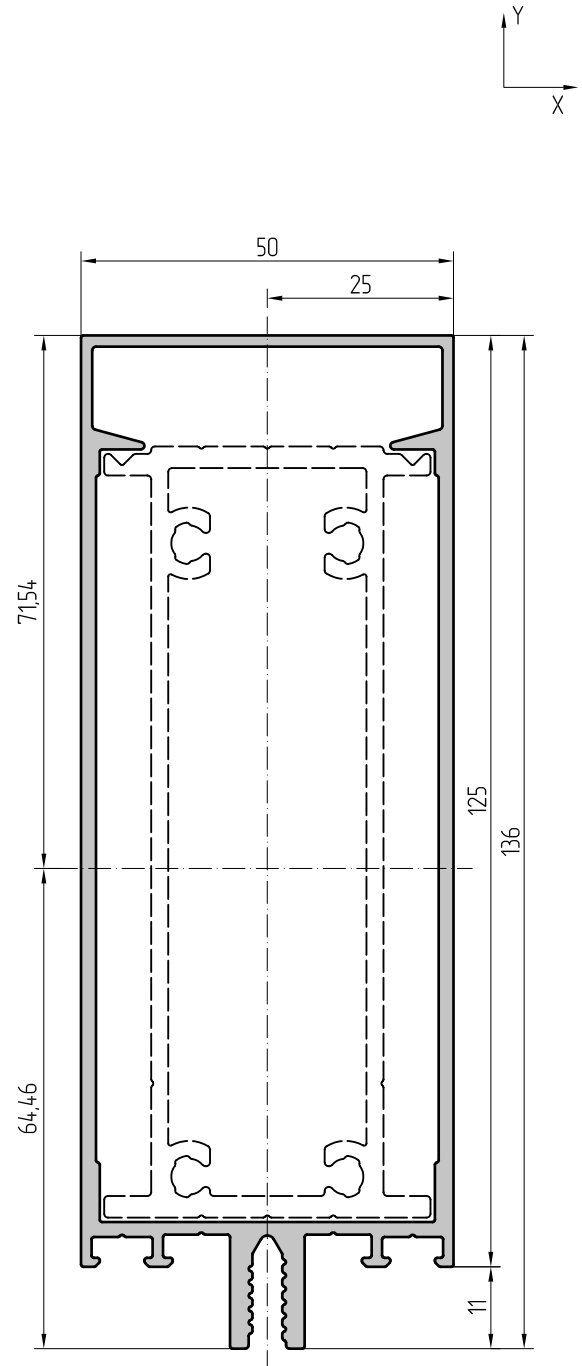
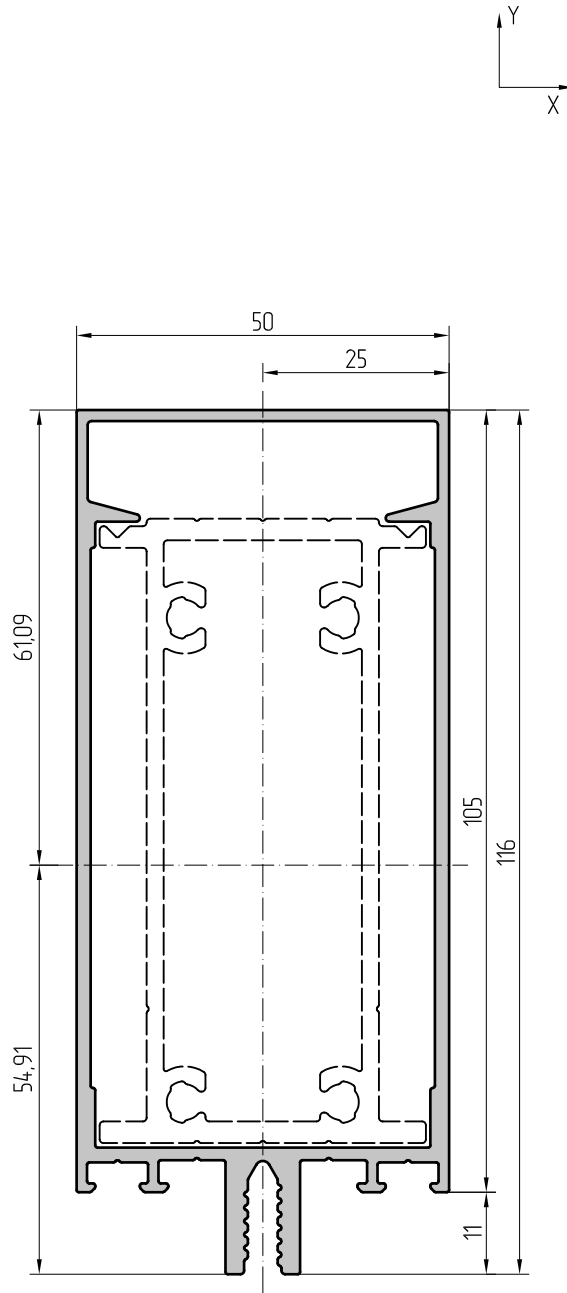

Scale 1:1	Transom 105 mm			Scale 1:1	Transom 125 mm		
AYPC.F50.0207	Article	Central moments of inertia		AYPC.F50.0208	Article	Central moments of inertia	
1,857 kg	Theoretical weight 1 m	$J_x=104,64 \text{ cm}^4$	$J_y=27,50 \text{ cm}^4$	2,113 kg	Theoretical weight 1 m	$J_x=163,29 \text{ cm}^4$	$J_y=32,86 \text{ cm}^4$
4,06,4 mm	External perimeter	Moments of resistance		4,46,4 mm	External perimeter	Moments of resistance	
6,854 cm <sup>2</sup>	Cross section area	$W_x=17,13 \text{ cm}^3$	$W_y=11,00 \text{ cm}^3$	7,796 cm <sup>2</sup>	Cross section area	$W_x=22,82 \text{ cm}^3$	$W_y=13,14 \text{ cm}^3$
		Radius of inertia				Radius of inertia	
		$i_x=3,91 \text{ cm}$	$i_y=2,00 \text{ cm}$			$i_x=4,55 \text{ cm}$	$i_y=2,05 \text{ cm}$

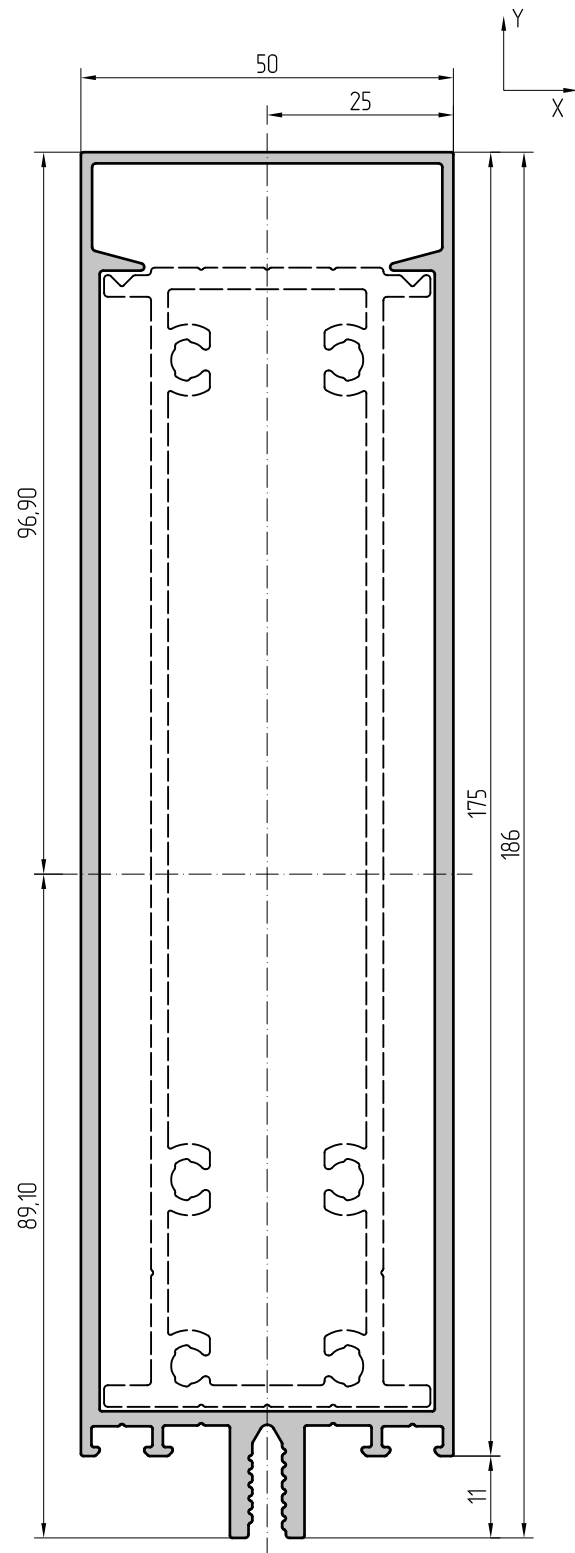
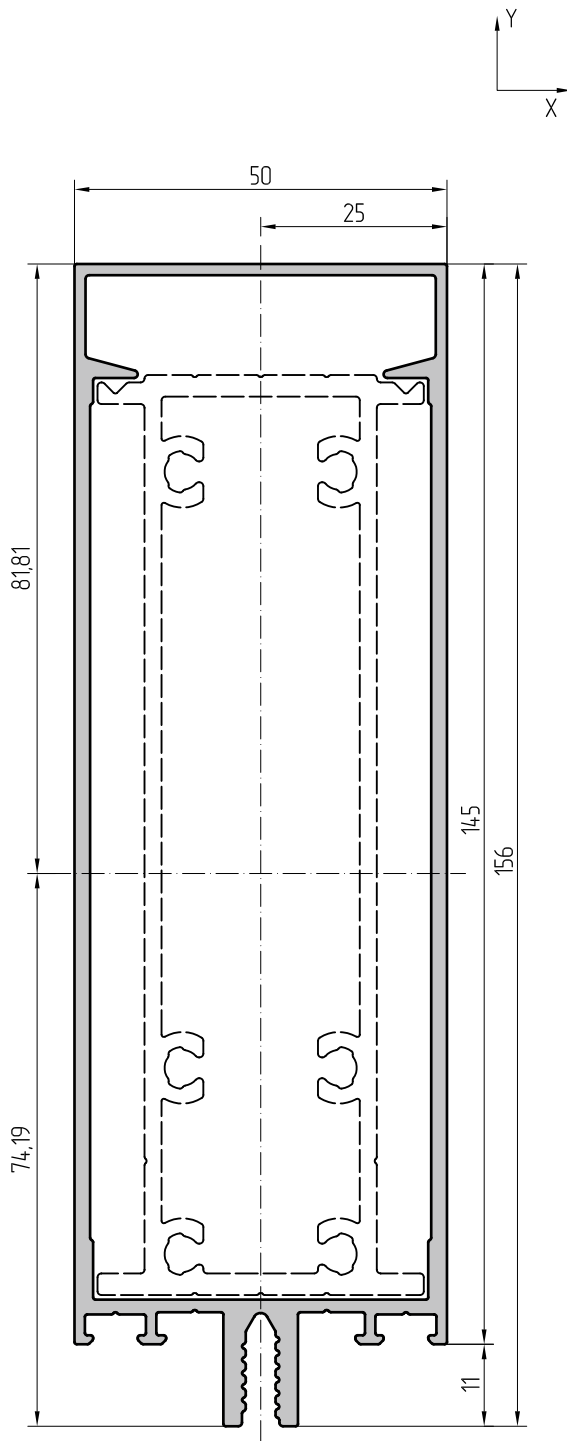

Scale 1:1		Transom 145 mm		Scale 1:1		Transom 175 mm	
AYPC.F50.0209	Article	Central moments of inertia		AYPC.F50.0210	Article	Central moments of inertia	
2,390 kg	Theoretical weight 1 m	Jx=235,40 cm <sup>4</sup>	Jy=38,65 cm <sup>4</sup>	3,035 kg	Theoretical weight 1 m	Jx=398,76 cm <sup>4</sup>	Jy=51,72 cm <sup>4</sup>
486,4 mm	External perimeter	Moments of resistance		545,6 mm	External perimeter	Moments of resistance	
8,820 cm <sup>2</sup>	Cross section area	Wx=28,77 cm <sup>3</sup>	Wy=15,46 cm <sup>3</sup>	11,242 cm <sup>2</sup>	Cross section area	Wx=41,05 cm <sup>3</sup>	Wy=20,69 cm <sup>3</sup>
		Radius of inertia				Radius of inertia	
		ix=5,17 cm	iy=2,09 cm			ix=5,96 cm	iy=2,14 cm

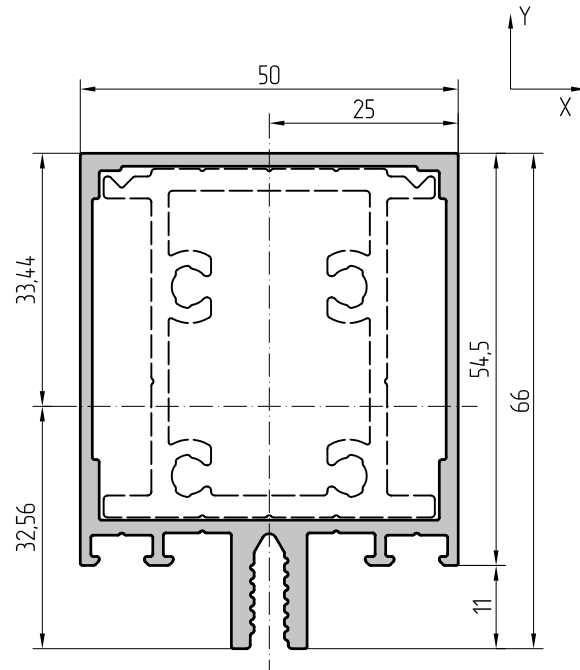
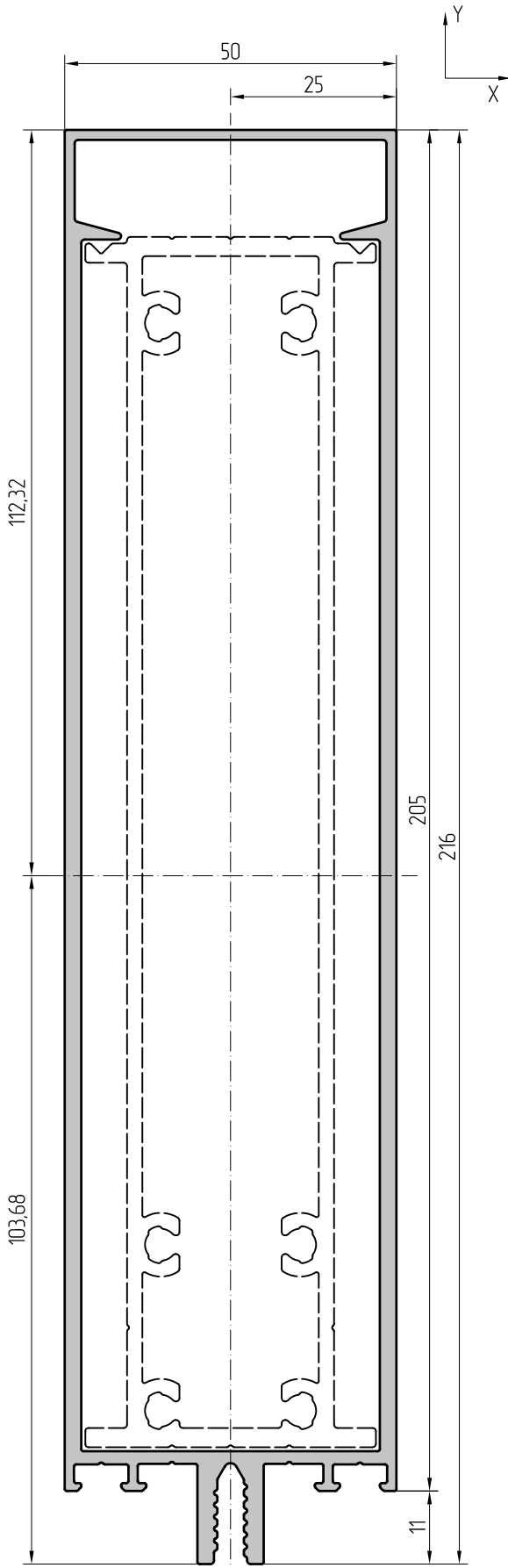

Scale 11		Transom 54,5 mm	
AYPC.F50.0214	Article	Central moments of inertia	
1,274 kg	Theoretical weight 1 m	$J_x=22,84 \text{ cm}^4$	$J_y=15,13 \text{ cm}^4$
305,4 mm	External perimeter	Moments of resistance	
4,717 $\text{cm}^2$	Cross section area	$W_x=6,83 \text{ cm}^3$	$W_y=6,05 \text{ cm}^3$
		Radius of inertia	
		$i_x=2,20 \text{ cm}$	$i_y=1,79 \text{ cm}$

Scale 11		Transom 205 mm	
AYPC.F50.0211	Article	Central moments of inertia	
3,437 kg	Theoretical weight 1 m	$J_x=600,88 \text{ cm}^4$	$J_y=61,13 \text{ cm}^4$
605,6 mm	External perimeter	Moments of resistance	
12,730 $\text{cm}^2$	Cross section area	$W_x=54,00 \text{ cm}^3$	$W_y=24,45 \text{ cm}^3$
		Radius of inertia	
		$i_x=5,96 \text{ cm}$	$i_y=2,14 \text{ cm}$

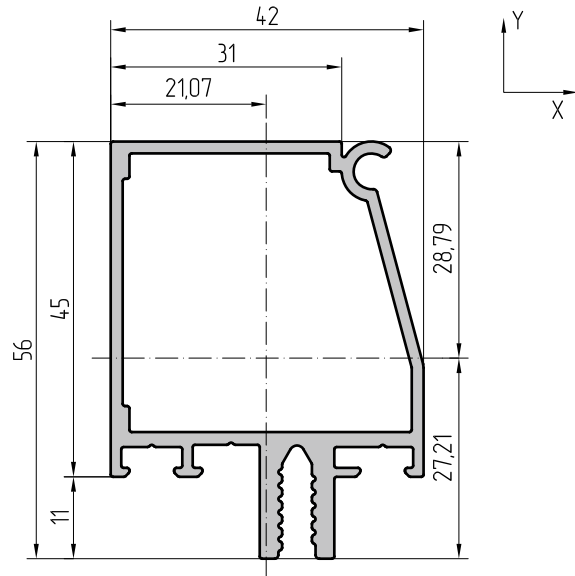
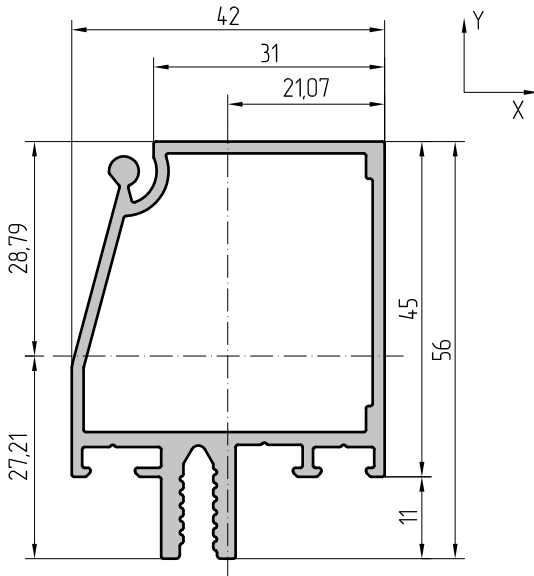

Scale 11		Transom 45 mm	
AYPC.F50.0212	Article	Central moments of inertia	
1,061 kg	Theoretical weight 1 m	Jx=12,57 cm <sup>4</sup>	Jy=7,53 cm <sup>4</sup>
271,8 mm	External perimeter	Moments of resistance	
3,928 cm <sup>2</sup>	Cross section area	Wx=4,37 cm <sup>3</sup>	Wy=3,57 cm <sup>3</sup>
		Radius of inertia	
		ix=1,79 cm	iy=1,38 cm

Scale 11		Transom 45 mm	
AYPC.F50.0213	Article	Central moments of inertia	
1,042 kg	Theoretical weight 1 m	Jx=12,45 cm <sup>4</sup>	Jy=7,43 cm <sup>4</sup>
269,0 mm	External perimeter	Moments of resistance	
3,861 cm <sup>2</sup>	Cross section area	Wx=4,28 cm <sup>3</sup>	Wy=3,52 cm <sup>3</sup>
		Radius of inertia	
		ix=1,79 cm	iy=1,39 cm

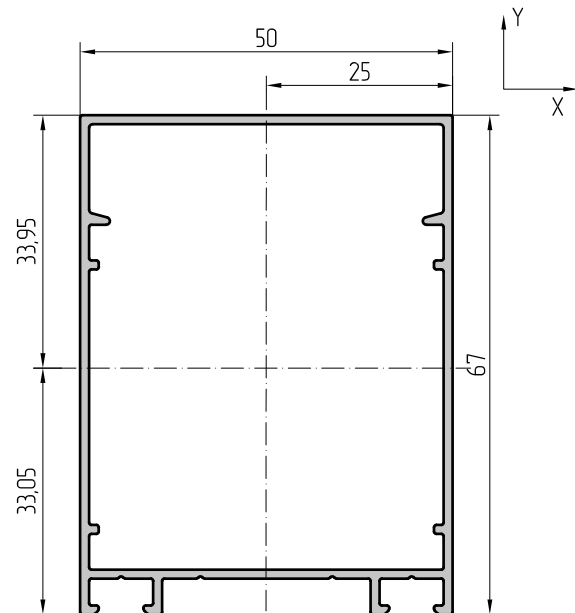
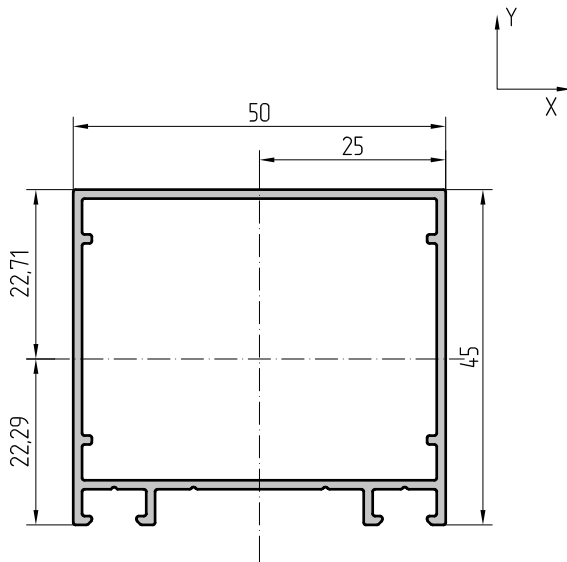

Scale 11		Transom 45 mm	
AYPC.F50.0215	Article	Central moments of inertia	
0,661 kg	Theoretical weight 1 m	Jx=7,06 cm <sup>4</sup>	Jy=9,37 cm <sup>4</sup>
225,9 mm	External perimeter	Moments of resistance	
2,449 cm <sup>2</sup>	Cross section area	Wx=3,11 cm <sup>3</sup>	Wy=3,75 cm <sup>3</sup>
		Radius of inertia	
		ix=2,31 cm	iy=1,95 cm

Scale 11		Transom 67 mm	
AYPC.F50.0216	Article	Central moments of inertia	
0,822 kg	Theoretical weight 1 m	Jx=18,84 cm <sup>4</sup>	Jy=12,88 cm <sup>4</sup>
269,9 mm	External perimeter	Moments of resistance	
3,047 cm <sup>2</sup>	Cross section area	Wx=5,45 cm <sup>3</sup>	Wy=5,15 cm <sup>3</sup>
		Radius of inertia	
		ix=2,48 cm	iy=2,05 cm

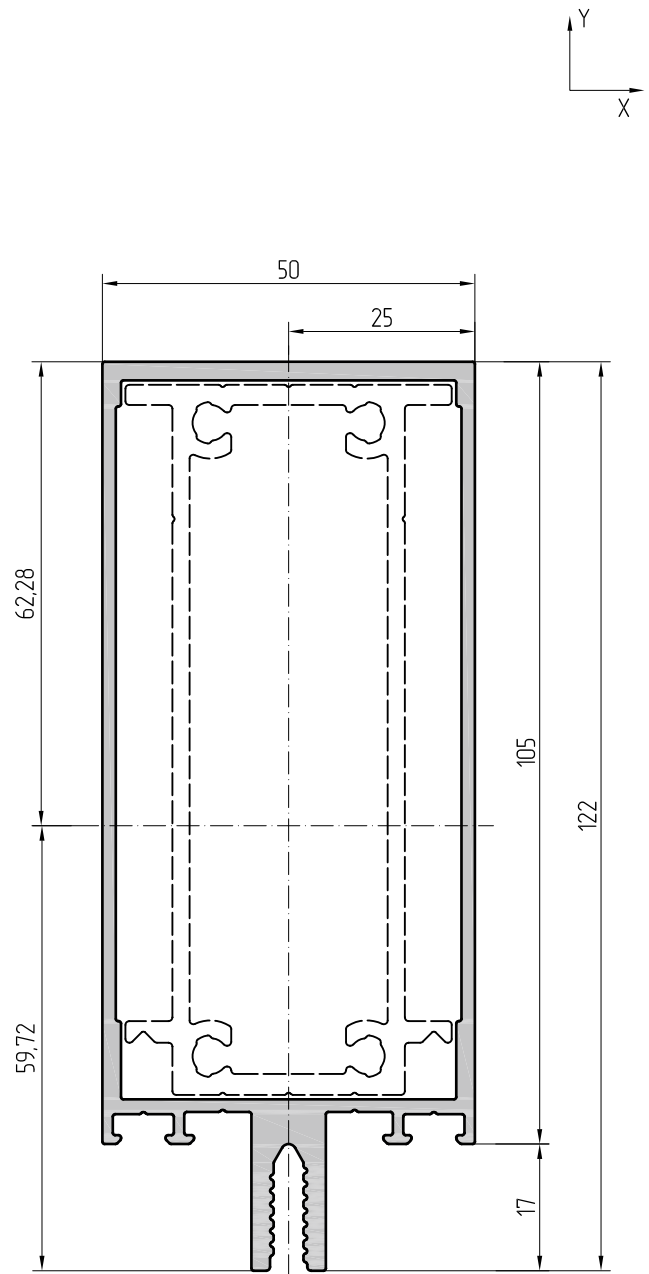
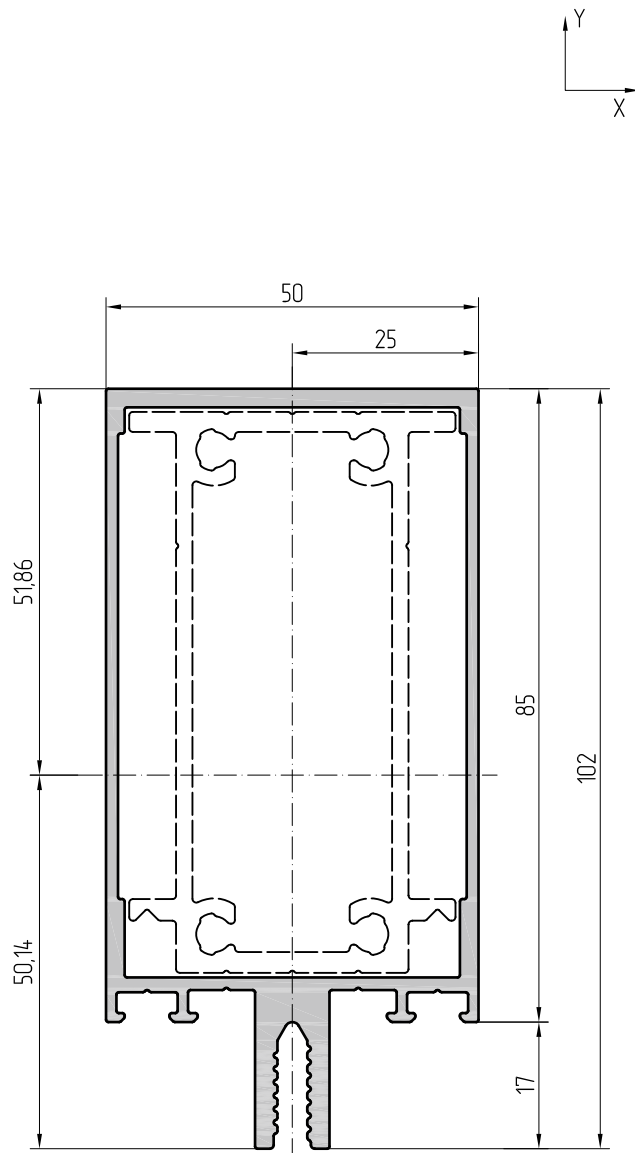

Scale 1:1	Transom 85 mm		
AYPC.F50.0226	Article	Central moments of inertia	
1,777 kg	Theoretical weight 1 m	Jx=80,78 cm <sup>4</sup>	Jy=21,59 cm <sup>4</sup>
383,0 mm	External perimeter	Moments of resistance	
6,580 cm <sup>2</sup>	Cross section area	Wx=15,56 cm <sup>3</sup>	Wy=8,64 cm <sup>3</sup>
		Radius of inertia	
		ix=3,50 cm	iy=1,81 cm

Scale 1:1	Transom 105 mm		
AYPC.F50.0227	Article	Central moments of inertia	
2,039 kg	Theoretical weight 1 m	Jx=132,24 cm <sup>4</sup>	Jy=27,13 cm <sup>4</sup>
422,9 mm	External perimeter	Moments of resistance	
7,555 cm <sup>2</sup>	Cross section area	Wx=21,23 cm <sup>3</sup>	Wy=10,85 cm <sup>3</sup>
		Radius of inertia	
		ix=4,18 cm	iy=1,89 cm



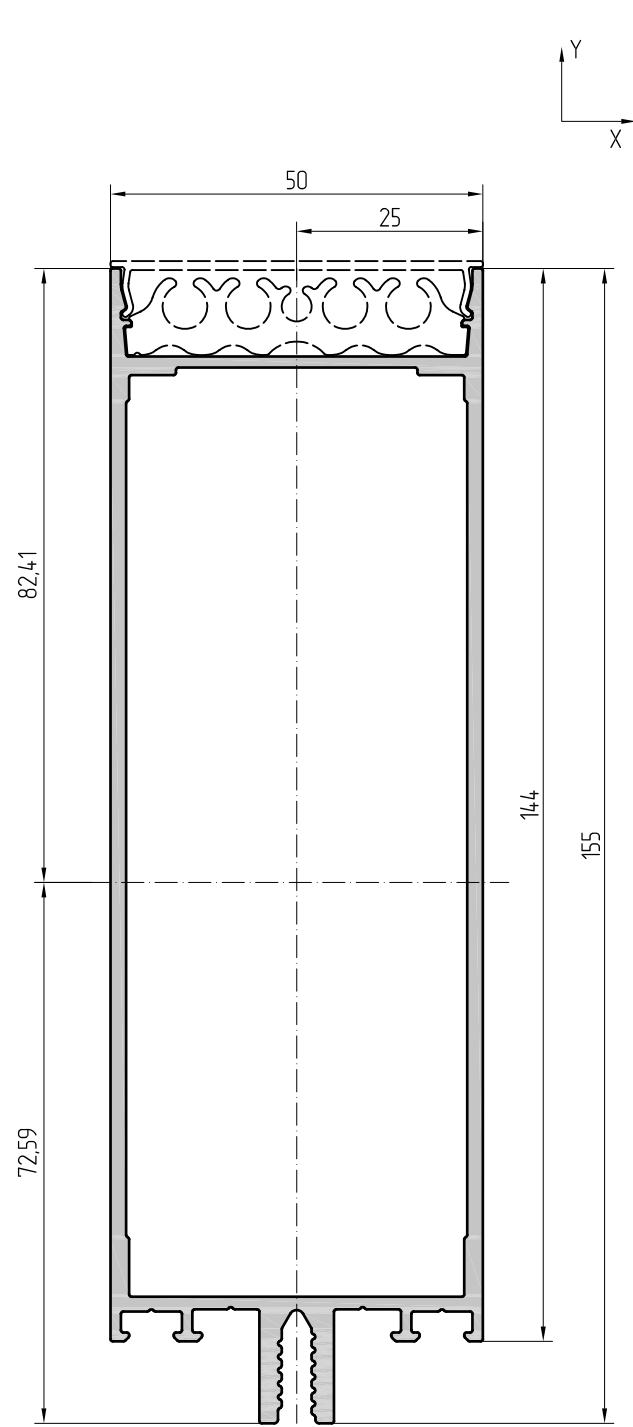
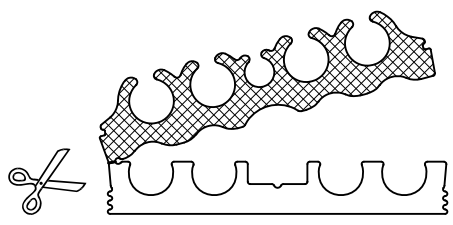
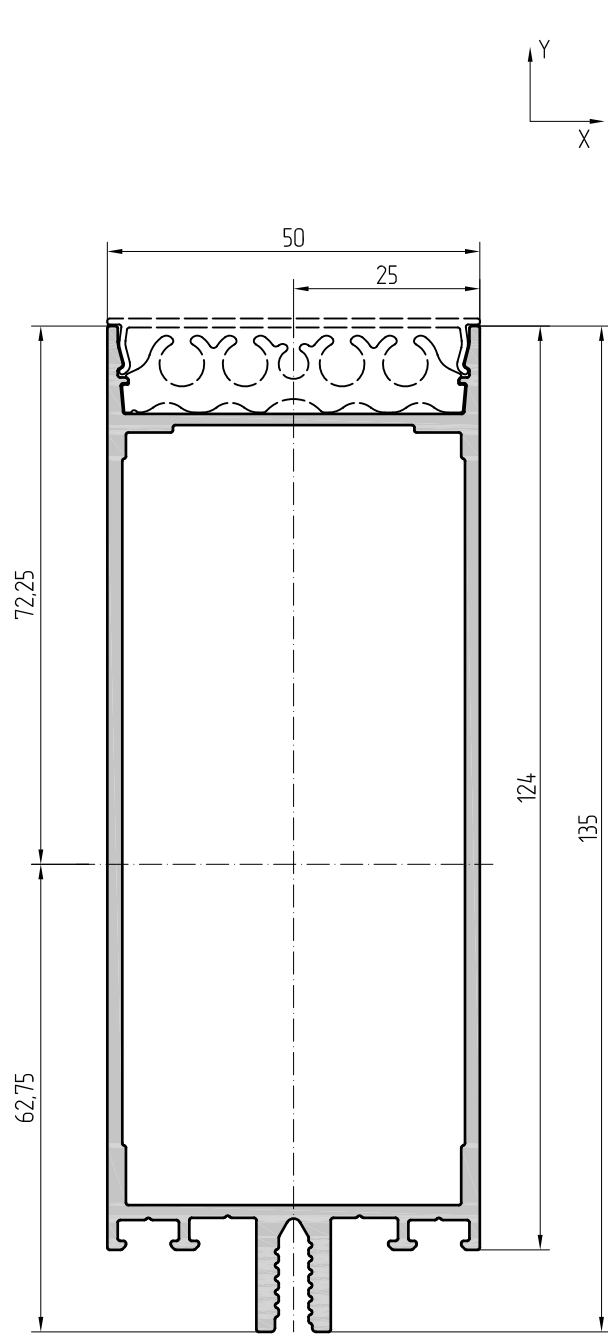

Scale 1:1	Transom 125 mm			Scale 1:1	Transom 145 mm		
AYPC.F50.0248	Article	Central moments of inertia		AYPC.F50.0249	Article	Central moments of inertia	
2,090 kg	Theoretical weight 1 m	Jx=146,9 cm <sup>4</sup>	Jy=32,5 cm <sup>4</sup>	2,360 kg	Theoretical weight 1 m	Jx=218,2 cm <sup>4</sup>	Jy=38,3 cm <sup>4</sup>
470,9 mm	External perimeter	Moments of resistance		510,9 mm	External perimeter	Moments of resistance	
7,724 cm <sup>2</sup>	Cross section area	Wx=20,33 cm <sup>3</sup>	Wy=13,00 cm <sup>3</sup>	8,748 cm <sup>2</sup>	Cross section area	Wx=26,48 cm <sup>3</sup>	Wy=15,32 cm <sup>3</sup>
		Radius of inertia				Radius of inertia	
		ix=4,36 cm	iy=2,05 cm			ix=4,99 cm	iy=2,09 cm

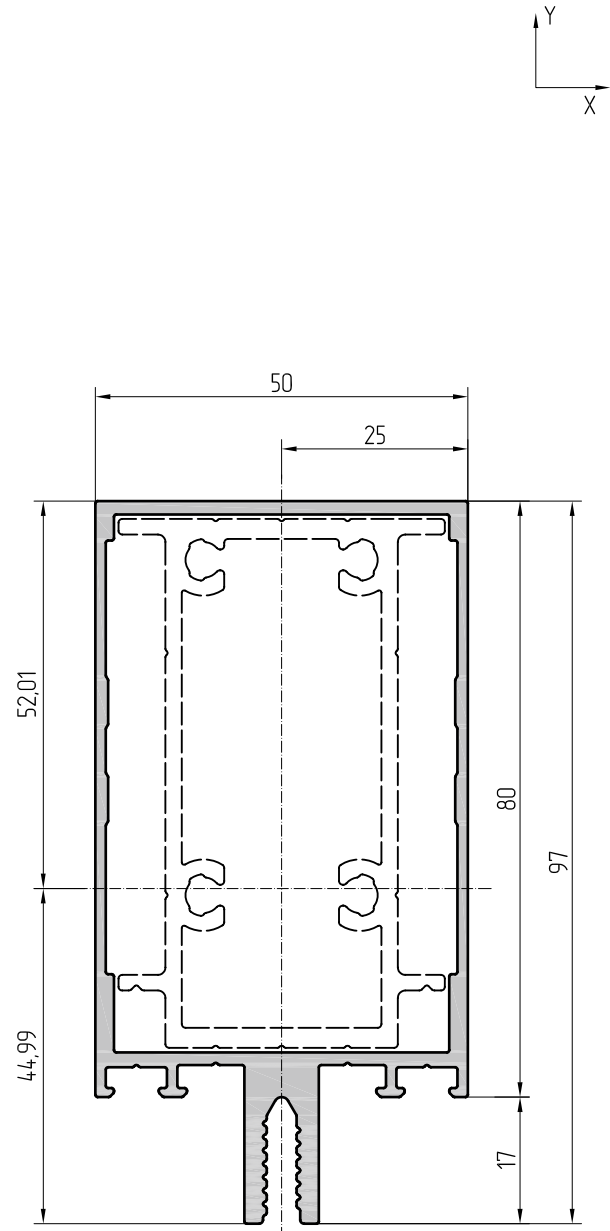
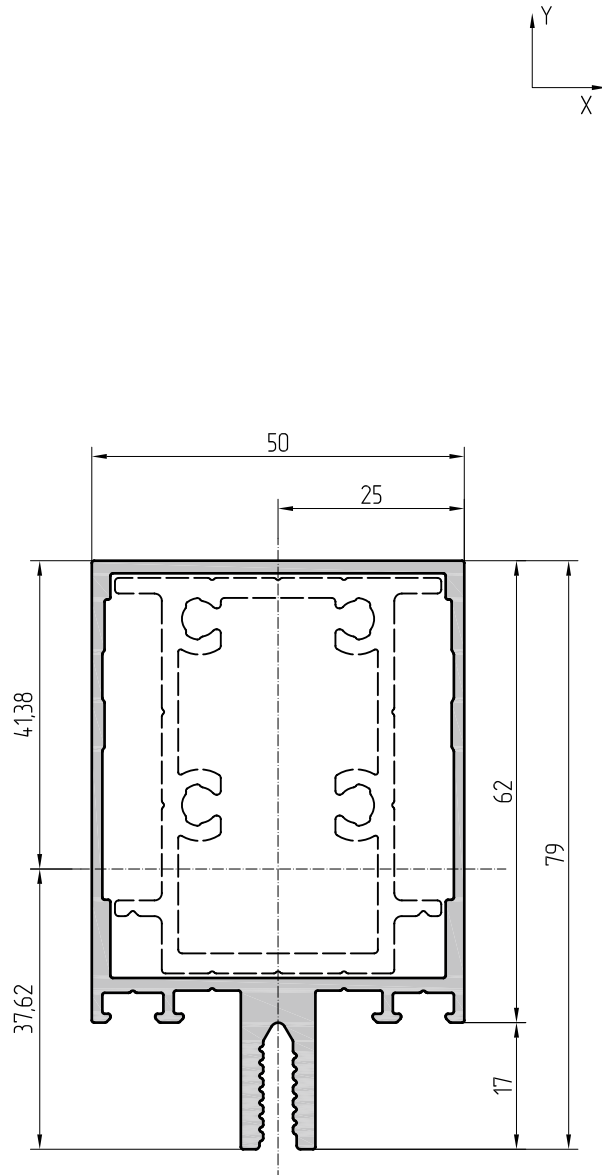

Scale 1:1	Transom 62 mm		
AYPC.F50.3102	Article	Central moments of inertia	
1,457 kg	Theoretical weight 1 m	$J_x=35,24 \text{ cm}^4$	$J_y=16,15 \text{ cm}^4$
336,9 mm	External perimeter	Moments of resistance	
5,397 cm <sup>2</sup>	Cross section area	$W_x=8,52 \text{ cm}^3$	$W_y=6,46 \text{ cm}^3$
		Radius of inertia	
		$i_x=2,56 \text{ cm}$	$i_y=1,73 \text{ cm}$

Scale 1:1	Transom 80 mm		
AYPC.F50.3103	Article	Central moments of inertia	
1,605 kg	Theoretical weight 1 m	$J_x=62,06 \text{ cm}^4$	$J_y=19,2 \text{ cm}^4$
372,9 mm	External perimeter	Moments of resistance	
5,945 cm <sup>2</sup>	Cross section area	$W_x=11,93 \text{ cm}^3$	$W_y=7,68 \text{ cm}^3$
		Radius of inertia	
		$i_x=3,23 \text{ cm}$	$i_y=1,8 \text{ cm}$

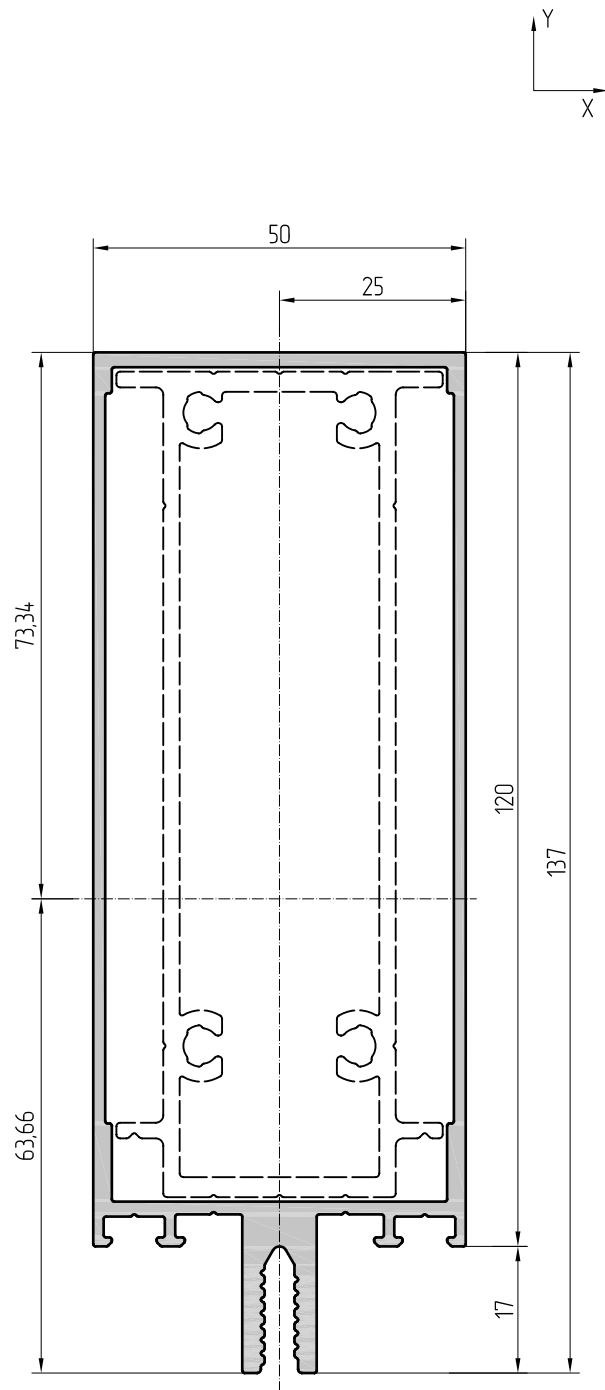
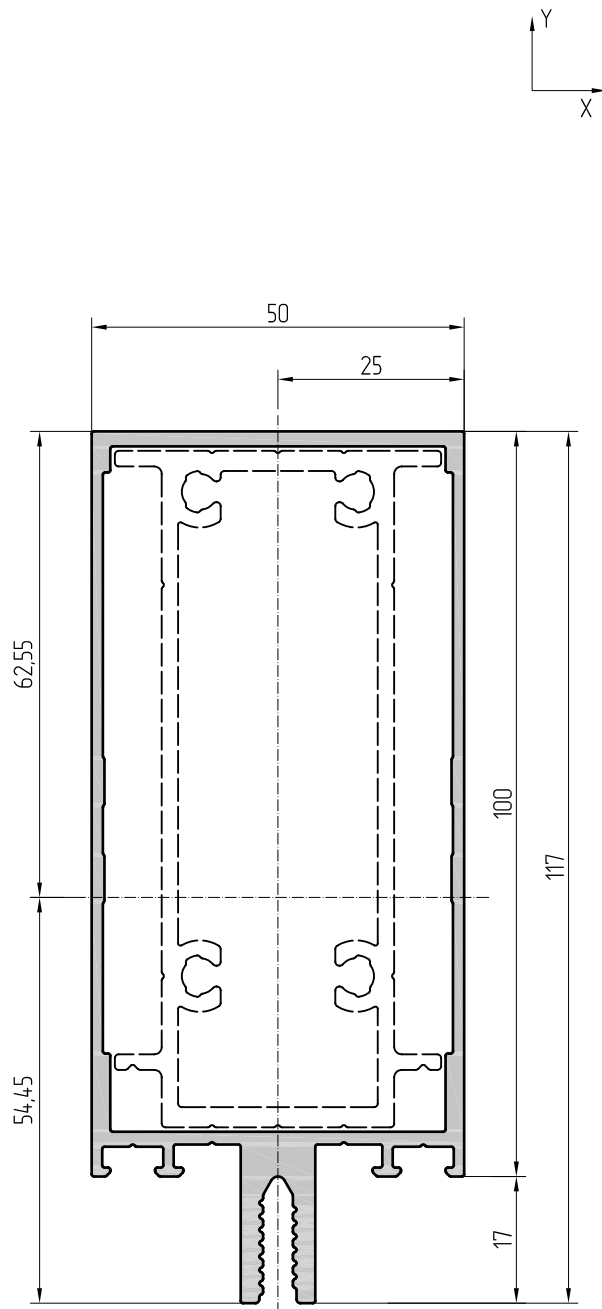

Scale 1:1		Transom 100 mm		Scale 1:1		Transom 80 mm	
AYPC.F50.3104	Article	Central moments of inertia		AYPC.F50.3105	Article	Central moments of inertia	
1,816 kg	Theoretical weight 1 m	$J_x=106,81 \text{ cm}^4$	$J_y=23,39 \text{ cm}^4$	2,018 kg	Theoretical weight 1 m	$J_x=164,13 \text{ cm}^4$	$J_y=27,72 \text{ cm}^4$
4,12,9 mm	External perimeter	Moments of resistance		4,52,9 mm	External perimeter	Moments of resistance	
6,728 cm <sup>2</sup>	Cross section area	$W_x=17,08 \text{ cm}^3$	$W_y=9,36 \text{ cm}^3$	7,473 cm <sup>2</sup>	Cross section area	$W_x=22,38 \text{ cm}^3$	$W_y=11,09 \text{ cm}^3$
		Radius of inertia				Radius of inertia	
		$i_x=3,98 \text{ cm}$	$i_y=1,86 \text{ cm}$			$i_x=4,69 \text{ cm}$	$i_y=1,93 \text{ cm}$

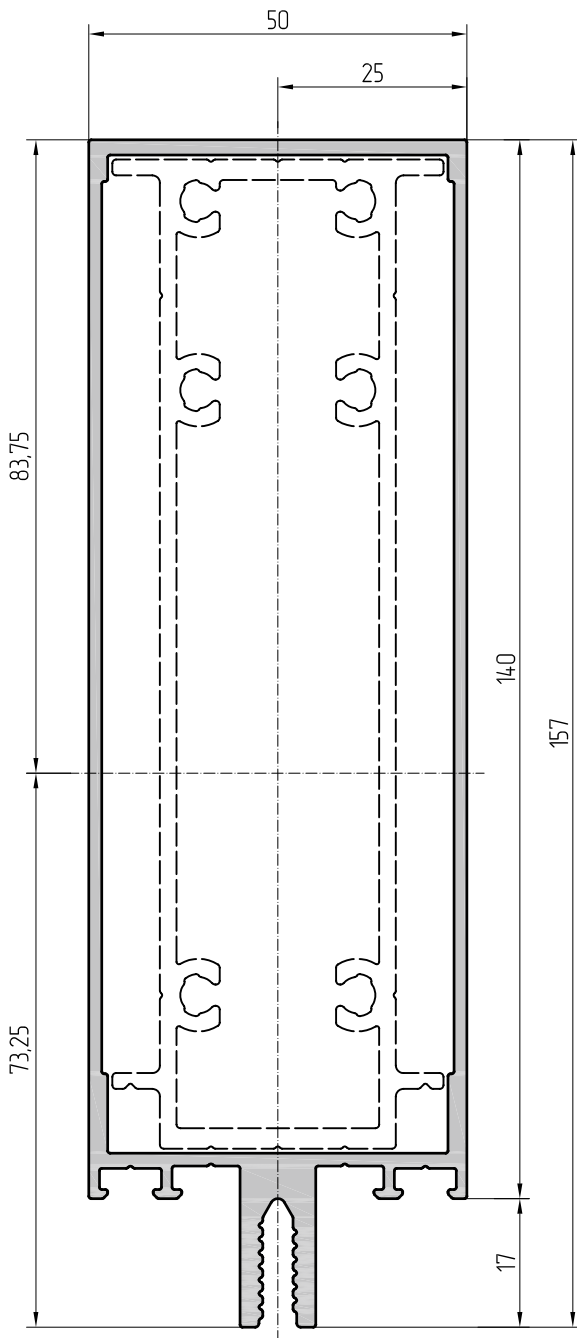
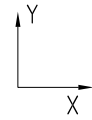

Scale 1:1		Transom 140 mm	
AYPC.F50.3104	Article	Central moments of inertia	
2,254 kg	Theoretical weight 1 m	$J_x=238,64 \text{ cm}^4$	$J_y=32,76 \text{ cm}^4$
492,9 mm	External perimeter	Moments of resistance	
8,349 cm <sup>2</sup>	Cross section area	$W_x=28,49 \text{ cm}^3$	$W_y=13,1 \text{ cm}^3$
		Radius of inertia	
		$i_x=5,35 \text{ cm}$	$i_y=1,98 \text{ cm}$

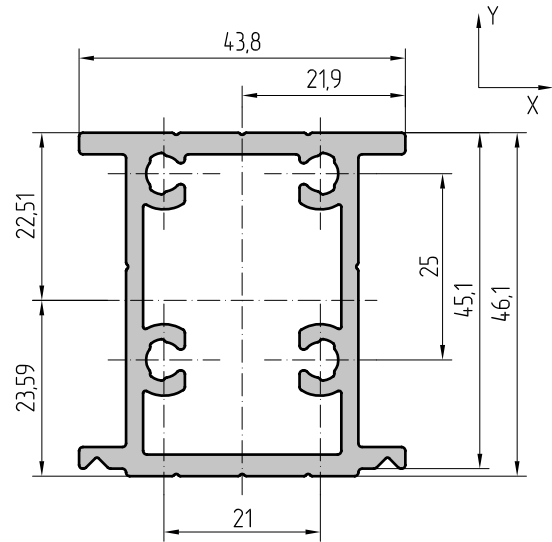
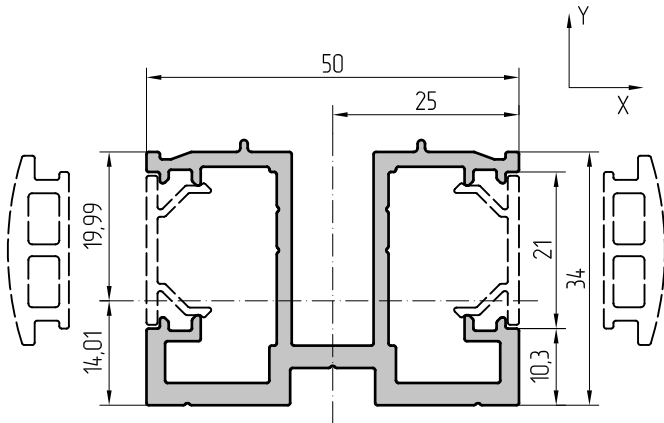

Scale 11		Reinforced profile 34 mm	
AYPC.F50.0301	Article	Central moments of inertia	
1,148 kg	Theoretical weight 1 m	$J_x=6,50 \text{ cm}^4$	$J_y=9,14 \text{ cm}^4$
377,7 mm	External perimeter	Moments of resistance	
4,235 cm <sup>2</sup>	Cross section area	$W_x=6,64 \text{ cm}^3$	$W_y=3,66 \text{ cm}^3$
		Radius of inertia	
		$i_x=1,24 \text{ cm}$	$i_y=1,47 \text{ cm}$

Scale 11		Reinforced profile 46,1 mm	
AYPC.F50.0302	Article	Central moments of inertia	
1,426 kg	Theoretical weight 1 m	$J_x=15,20 \text{ cm}^4$	$J_y=8,82 \text{ cm}^4$
205,5 mm	External perimeter	Moments of resistance	
5,282 cm <sup>2</sup>	Cross section area	$W_x=6,44 \text{ cm}^3$	$W_y=4,03 \text{ cm}^3$
		Radius of inertia	
		$i_x=1,70 \text{ cm}$	$i_y=1,29 \text{ cm}$

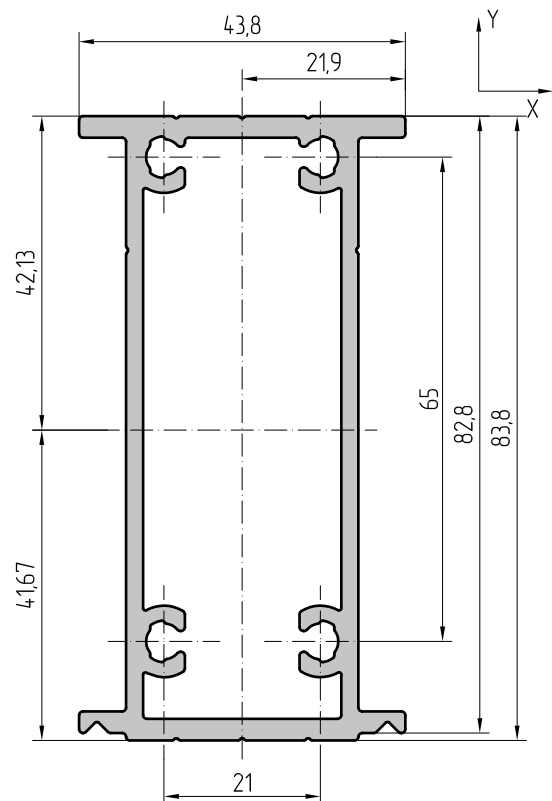
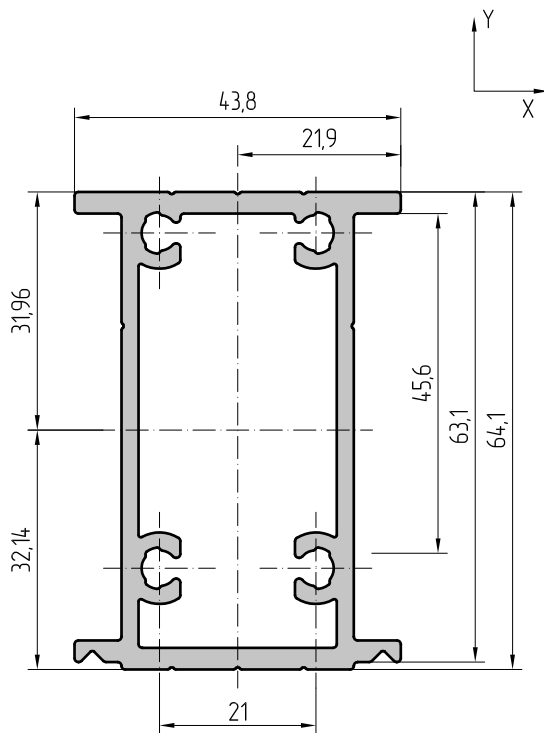

Scale 11		Reinforced profile 64,1 mm	
AYPC.F50.0303	Article	Central moments of inertia	
1,650 kg	Theoretical weight 1 m	$J_x=34,86 \text{ cm}^4$	$J_y=10,55 \text{ cm}^4$
241,5 mm	External perimeter	Moments of resistance	
6,110 cm <sup>2</sup>	Cross section area	$W_x=10,87 \text{ cm}^3$	$W_y=4,82 \text{ cm}^3$
		Radius of inertia	
		$i_x=2,39 \text{ cm}$	$i_y=1,31 \text{ cm}$

Scale 11		Reinforced profile 83,8 mm	
AYPC.F50.0304	Article	Central moments of inertia	
1,894 kg	Theoretical weight 1 m	$J_x=67,64 \text{ cm}^4$	$J_y=12,45 \text{ cm}^4$
280,9 mm	External perimeter	Moments of resistance	
7,016 cm <sup>2</sup>	Cross section area	$W_x=16,05 \text{ cm}^3$	$W_y=5,68 \text{ cm}^3$
		Radius of inertia	
		$i_x=3,10 \text{ cm}$	$i_y=1,33 \text{ cm}$

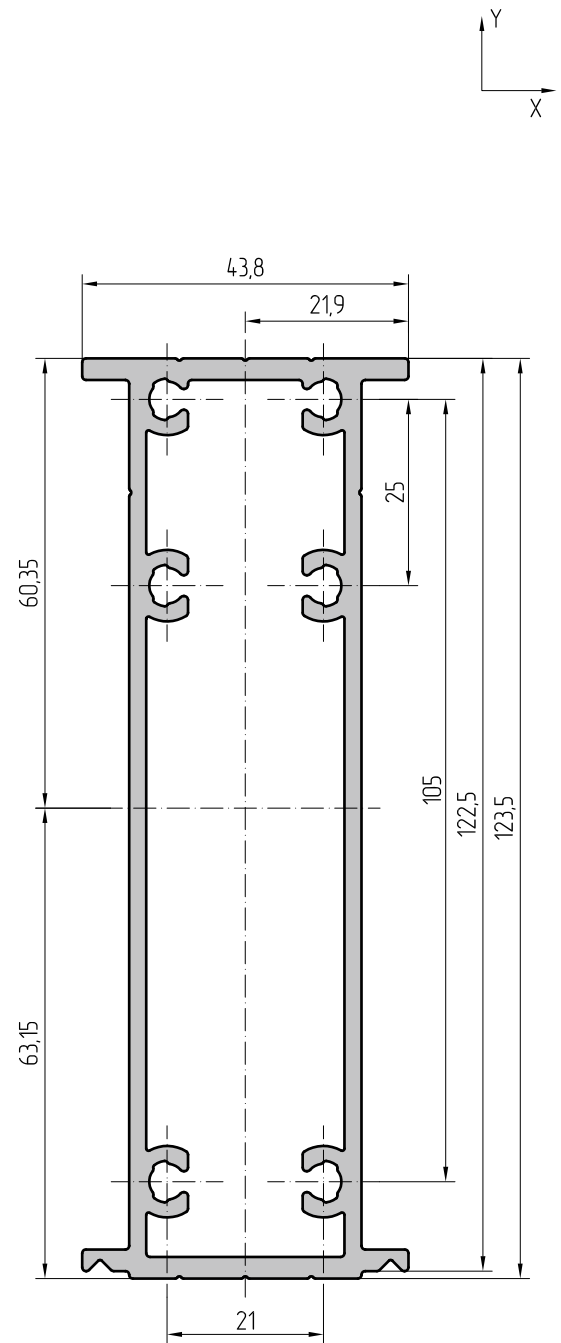
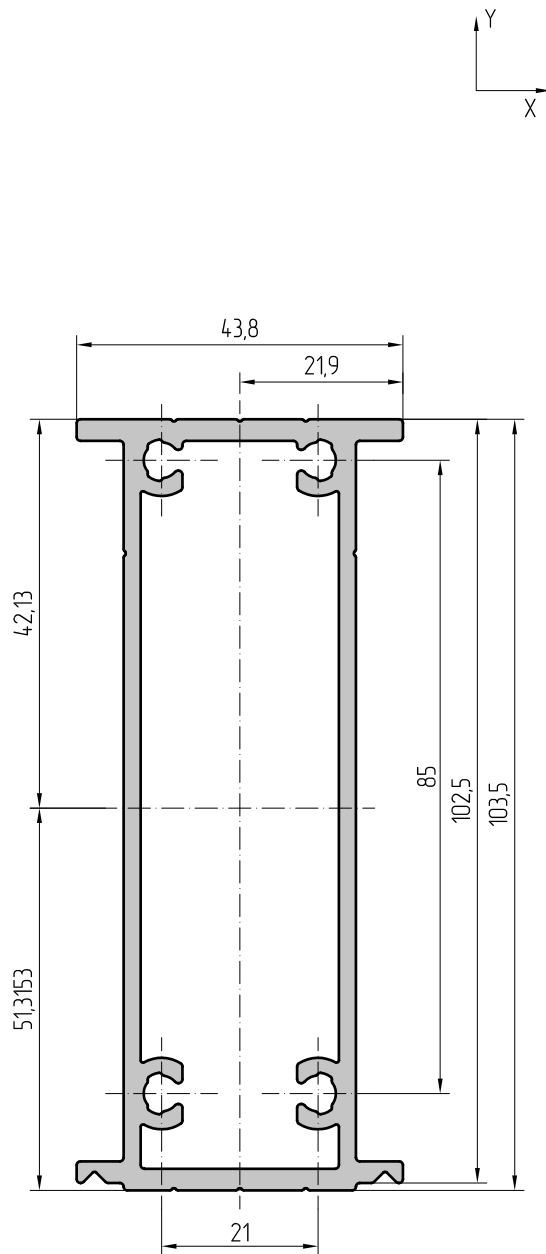

Scale 1:1	Reinforced profile 103,5 mm		Scale 1:1	Reinforced profile 123,5 mm	
AYPC.F50.0305	Article	Central moments of inertia	AYPC.F50.0306	Article	Central moments of inertia
2,139 kg	Theoretical weight 1 m	$J_x=114,09 \text{ cm}^4$   $J_y=14,41 \text{ cm}^4$	2,545 kg	Theoretical weight 1 m	$J_x=182,50 \text{ cm}^4$   $J_y=16,94 \text{ cm}^4$
320,3 mm	External perimeter	Moments of resistance	360,3 mm	External perimeter	Moments of resistance
7,923 cm <sup>2</sup>	Cross section area	$W_x=21,86 \text{ cm}^3$   $W_y=6,76 \text{ cm}^3$	9,427 cm <sup>2</sup>	Cross section area	$W_x=28,90 \text{ cm}^3$   $W_y=7,74 \text{ cm}^3$
		Radius of inertia			Radius of inertia
		$i_x=3,79 \text{ cm}$   $i_y=1,34 \text{ cm}$			$i_x=4,40 \text{ cm}$   $i_y=1,34 \text{ cm}$

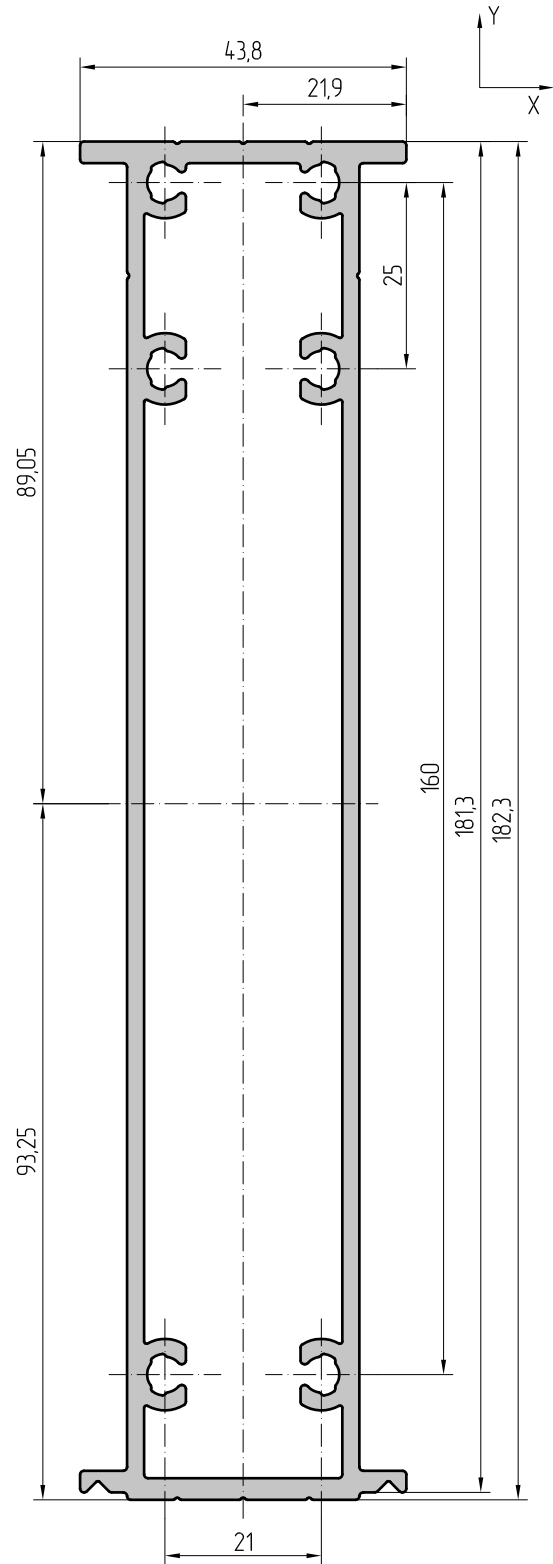
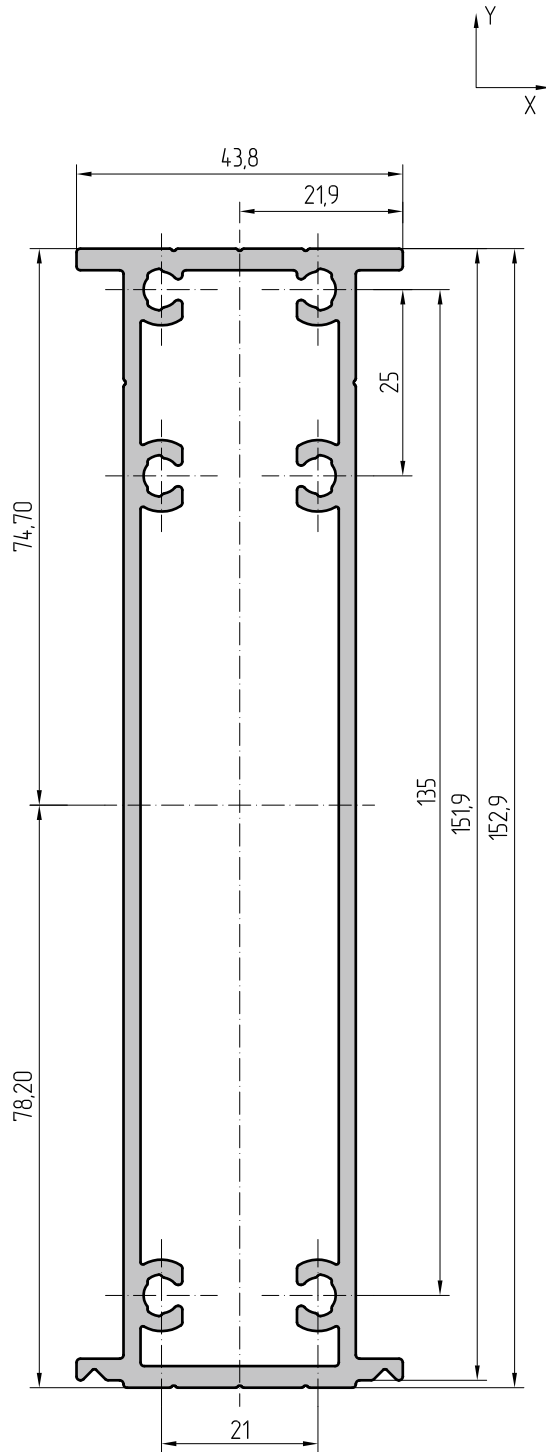

Scale 1:1		Reinforced profile 152,9 mm	
AYPC.F50.0307	Article	Central moments of inertia	
2,910 kg	Theoretical weight 1 m	$J_x=314,38 \text{ cm}^4$	$J_y=19,77 \text{ cm}^4$
4,19,1 mm	External perimeter	Moments of resistance	
10,780 cm <sup>2</sup>	Cross section area	$W_x=40,20 \text{ cm}^3$	$W_y=9,03 \text{ cm}^3$
		Radius of inertia	
		$i_x=5,40 \text{ cm}$	$i_y=1,35 \text{ cm}$

Scale 1:1		Reinforced profile 182,3 mm	
AYPC.F50.0308	Article	Central moments of inertia	
3,276 kg	Theoretical weight 1 m	$J_x=488,42 \text{ cm}^4$	$J_y=22,60 \text{ cm}^4$
4,77,9 mm	External perimeter	Moments of resistance	
12,132 cm <sup>2</sup>	Cross section area	$W_x=52,38 \text{ cm}^3$	$W_y=10,32 \text{ cm}^3$
		Radius of inertia	
		$i_x=6,34 \text{ cm}$	$i_y=1,36 \text{ cm}$

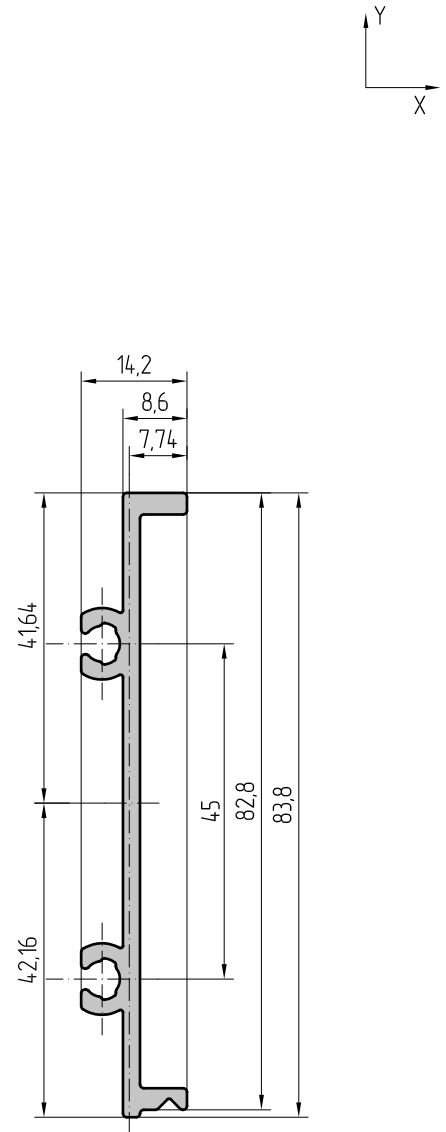
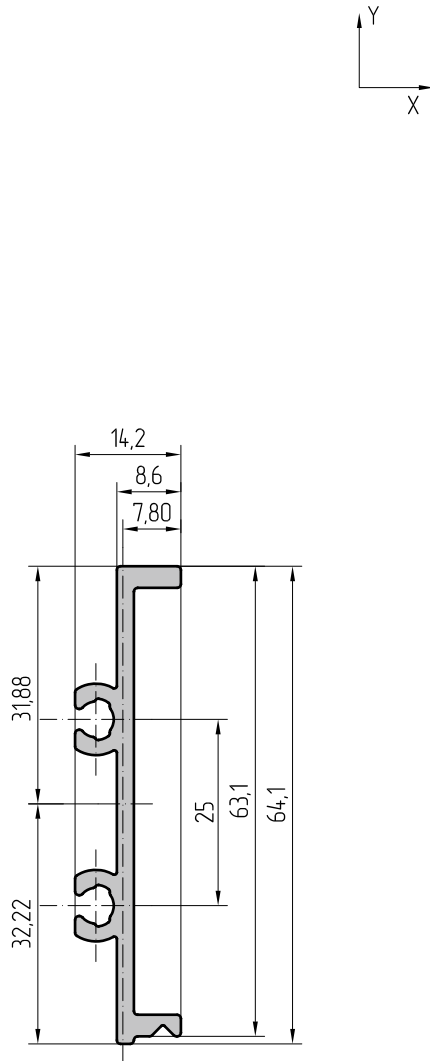

Scale 1:1	Reinforced profile 64,1 mm			Scale 1:1	Reinforced profile 83,8 mm		
AYPC.F50.0313	Article	Central moments of inertia		AYPC.F50.0314	Article	Central moments of inertia	
0,647 kg	Theoretical weight 1 m	$J_x=9,07 \text{ cm}^4$	$J_y=0,18 \text{ cm}^4$	0,772 kg	Theoretical weight 1 m	$J_x=19,67 \text{ cm}^4$	$J_y=0,18 \text{ cm}^4$
202,4 mm	External perimeter	Moments of resistance		241,8 mm	External perimeter	Moments of resistance	
2,396 cm <sup>2</sup>	Cross section area	$W_x=2,81 \text{ cm}^3$	$W_y=0,23 \text{ cm}^3$	2,849 cm <sup>2</sup>	Cross section area	$W_x=4,66 \text{ cm}^3$	$W_y=0,23 \text{ cm}^3$
		Radius of inertia				Radius of inertia	
		$i_x=1,95 \text{ cm}$	$i_y=0,27 \text{ cm}$			$i_x=2,63 \text{ cm}$	$i_y=0,25 \text{ cm}$



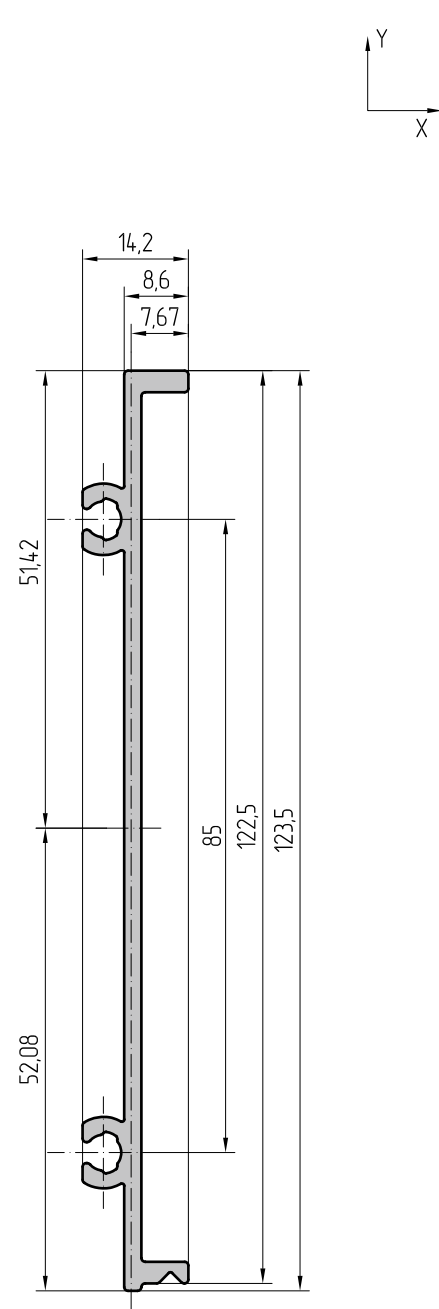
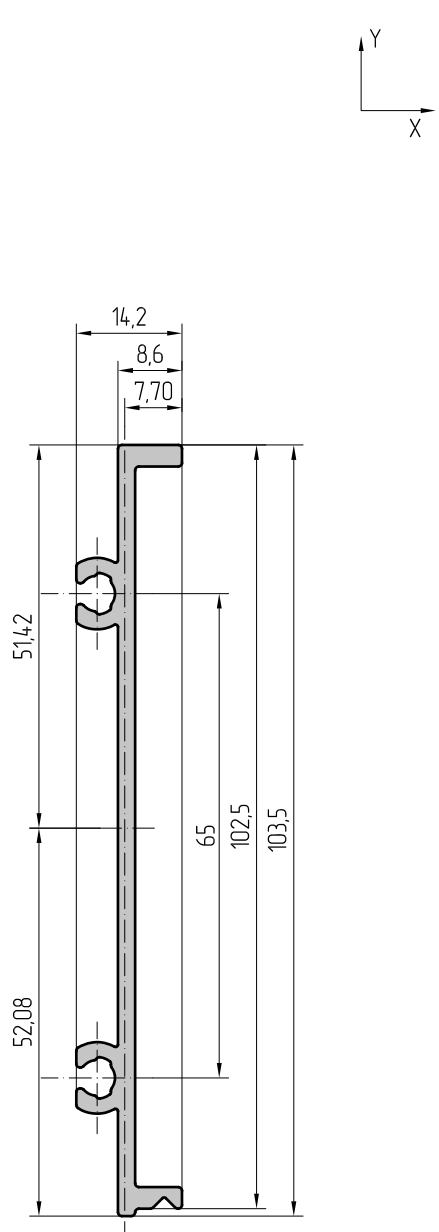

Scale 1:1		Reinforced profile 103,5 mm		Scale 1:1		Reinforced profile 123,5 mm	
AYPC.F50.0315	Article	Central moments of inertia		AYPC.F50.0316	Article	Central moments of inertia	
0,895 kg	Theoretical weight 1 m	$J_x=35,83 \text{ cm}^4$	$J_y=0,18 \text{ cm}^4$	1,019 kg	Theoretical weight 1 m	$J_x=58,76 \text{ cm}^4$	$J_y=0,19 \text{ cm}^4$
281,2 mm	External perimeter	Moments of resistance		321,2 mm	External perimeter	Moments of resistance	
3,302 cm <sup>2</sup>	Cross section area	$W_x=6,88 \text{ cm}^3$	$W_y=0,23 \text{ cm}^3$	3,762 cm <sup>2</sup>	Cross section area	$W_x=9,46 \text{ cm}^3$	$W_y=0,25 \text{ cm}^3$
		Radius of inertia				Radius of inertia	
		$i_x=3,29 \text{ cm}$	$i_y=0,24 \text{ cm}$			$i_x=3,95 \text{ cm}$	$i_y=0,22 \text{ cm}$

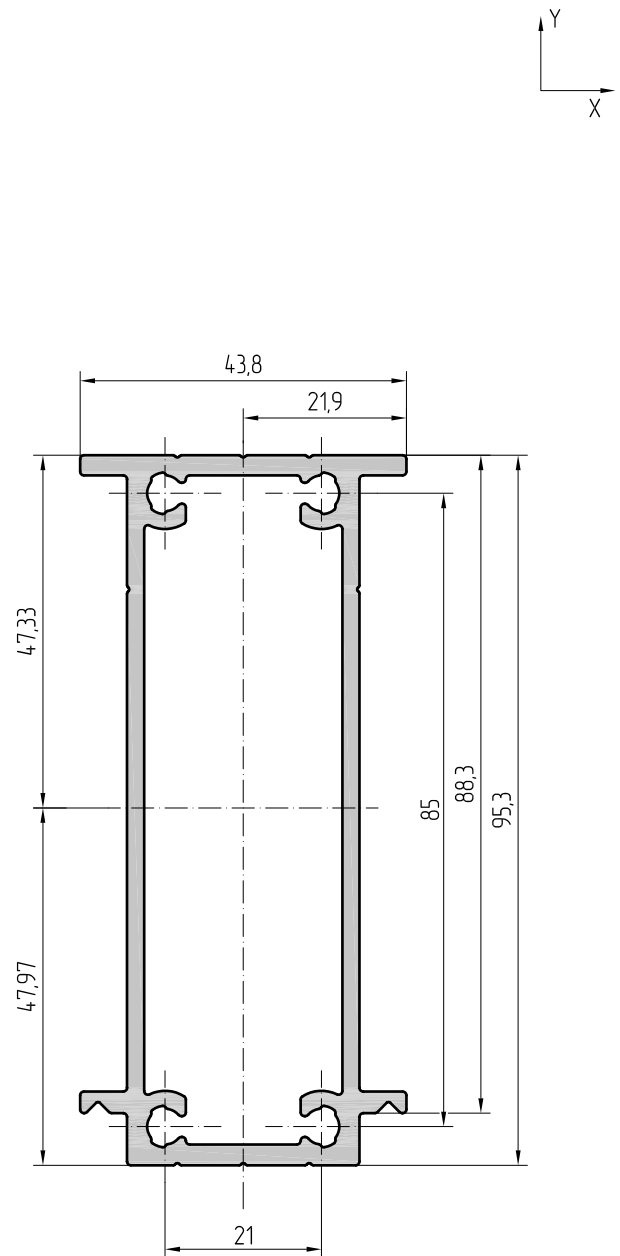
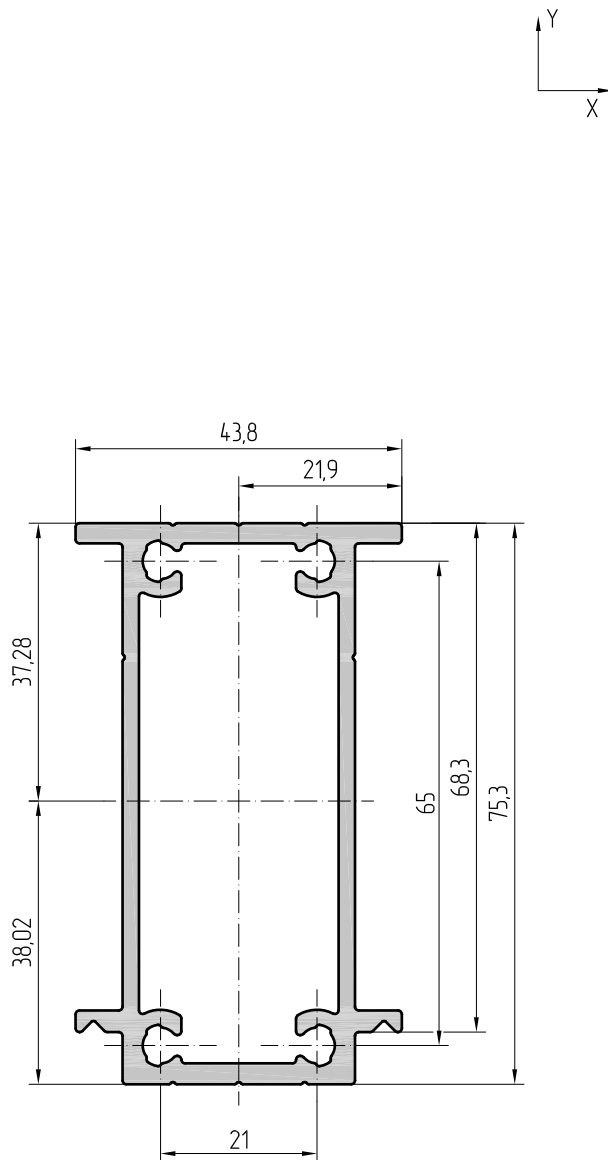

Scale 1:1	Reinforced profile 75,3 mm		
AYPC.F50.0326	Article	Central moments of inertia	
1,661 kg	Theoretical weight 1 m	$J_x=48,63 \text{ cm}^4$	$J_y=11,00 \text{ cm}^4$
263,9 mm	External perimeter	Moments of resistance	
$6,150 \text{ cm}^2$	Cross section area	$W_x=12,79 \text{ cm}^3$	$W_y=5,02 \text{ cm}^3$
		Radius of inertia	
		$i_x=2,81 \text{ cm}$	$i_y=1,34 \text{ cm}$

Scale 1:1	Reinforced profile 95,3 mm		
AYPC.F50.0327	Article	Central moments of inertia	
1,940 kg	Theoretical weight 1 m	$J_x=87,57 \text{ cm}^4$	$J_y=13,13 \text{ cm}^4$
303,9 mm	External perimeter	Moments of resistance	
$7,185 \text{ cm}^2$	Cross section area	$W_x=18,24 \text{ cm}^3$	$W_y=6,00 \text{ cm}^3$
		Radius of inertia	
		$i_x=3,49 \text{ cm}$	$i_y=1,35 \text{ cm}$

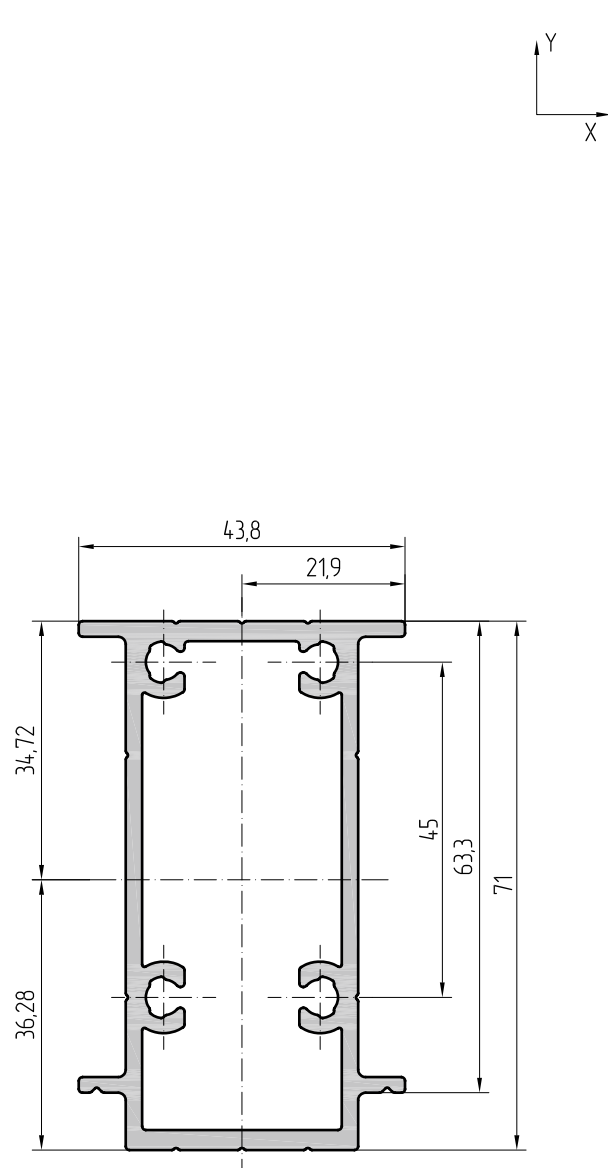
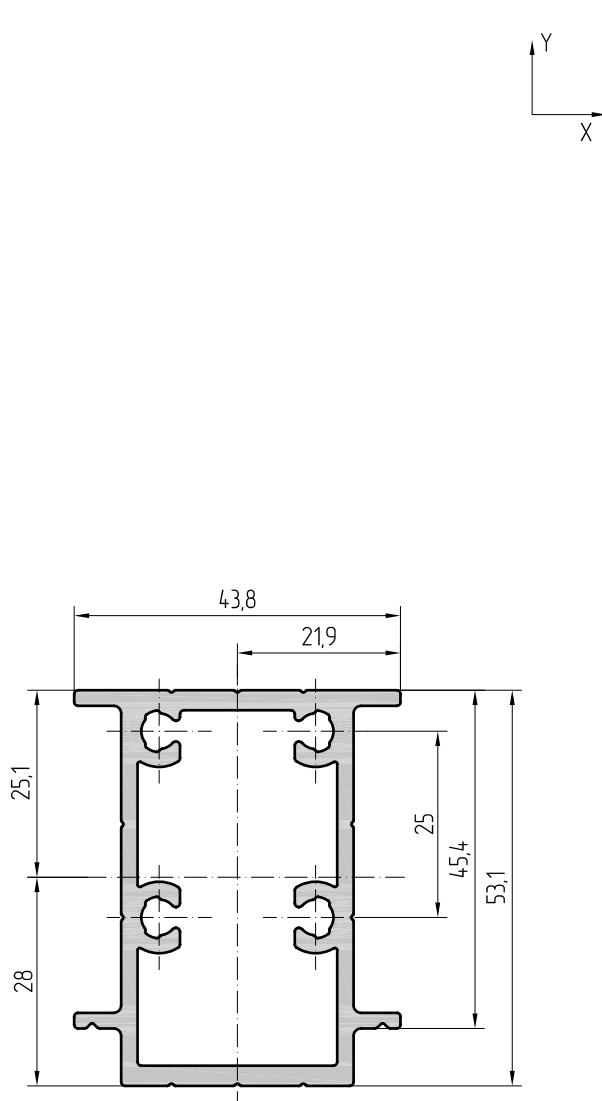

Scale 1:1		Reinforced profile 53,1 mm		Scale 1:1		Reinforced profile 71 mm	
AYPC.F50.3302	Article	Central moments of inertia		AYPC.F50.3303	Article	Central moments of inertia	
1,430 kg	Theoretical weight 1 m	Jx=18,74 cm <sup>4</sup>	Jy=8,79 cm <sup>4</sup>	1,643 kg	Theoretical weight 1 m	Jx=39,51 cm <sup>4</sup>	Jy=10,45 cm <sup>4</sup>
217,3 mm	External perimeter	Moments of resistance		253,1 mm	External perimeter	Moments of resistance	
5,298 cm <sup>2</sup>	Cross section area	Wx=6,69 cm <sup>3</sup>	Wy=4,01 cm <sup>3</sup>	6,086 cm <sup>2</sup>	Cross section area	Wx=10,89 cm <sup>3</sup>	Wy=4,77 cm <sup>3</sup>
		Radius of inertia				Radius of inertia	
		ix=1,88 cm	iy=1,29 cm			ix=2,55 cm	iy=1,31 cm

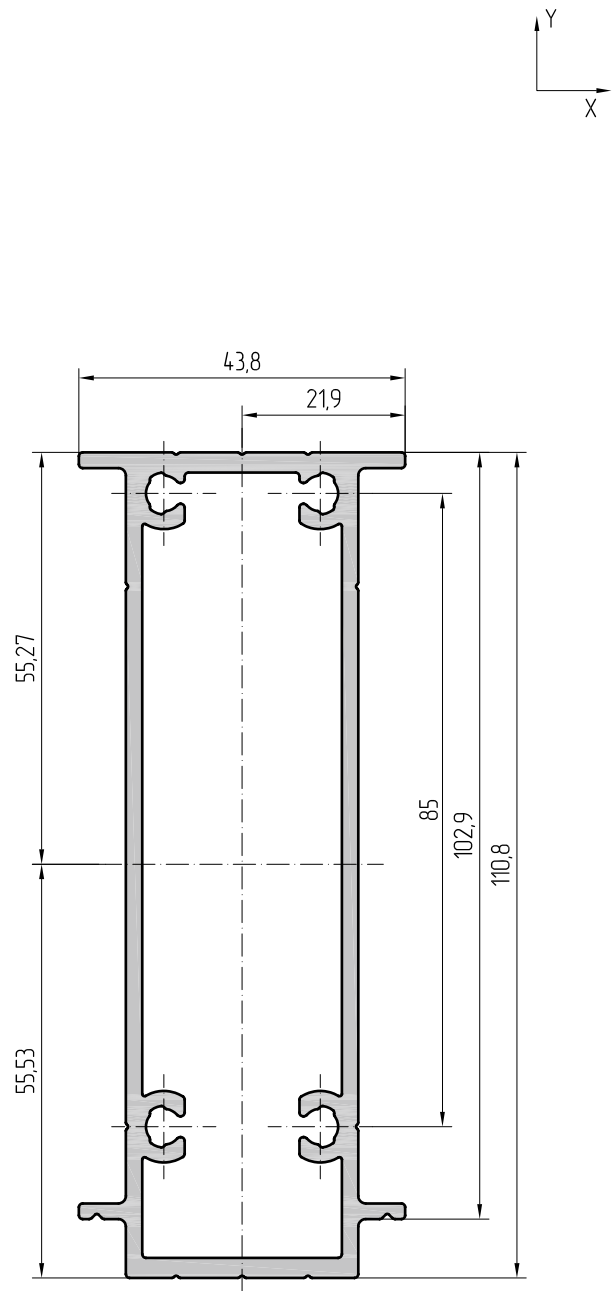
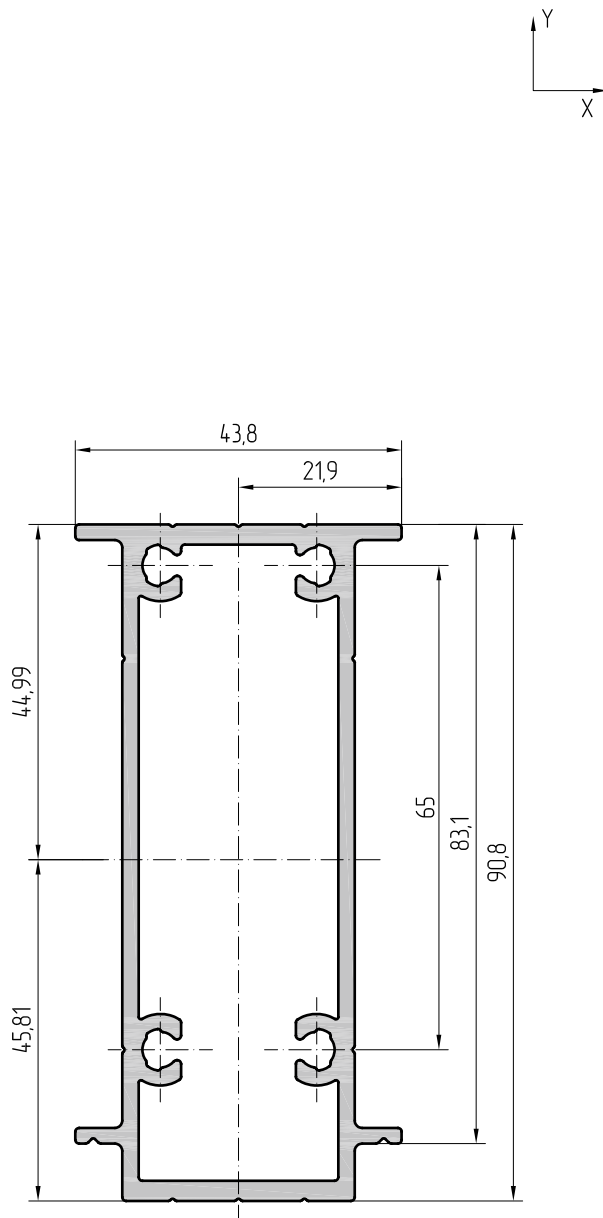

Scale 1:1	Reinforced profile 90,8 mm			
AYPC.F50.3304	Article	Central moments of inertia		
1,878 kg	Theoretical weight 1 m	$J_x=73,75 \text{ cm}^4$	$J_y=12,28 \text{ cm}^4$	
292,7 mm	External perimeter	Moments of resistance		
6,957 $\text{cm}^2$	Cross section area	$W_x=16,1 \text{ cm}^3$	$W_y=5,61 \text{ cm}^3$	
		Radius of inertia		
		$i_x=3,26 \text{ cm}$	$i_y=1,33 \text{ cm}$	

Scale 1:1	Reinforced profile 110,8 mm			
AYPC.F50.3305	Article	Central moments of inertia		
2,116 kg	Theoretical weight 1 m	$J_x=122,09 \text{ cm}^4$	$J_y=14,14 \text{ cm}^4$	
332,7 mm	External perimeter	Moments of resistance		
7,837 $\text{cm}^2$	Cross section area	$W_x=21,99 \text{ cm}^3$	$W_y=6,46 \text{ cm}^3$	
		Radius of inertia		
		$i_x=3,95 \text{ cm}$	$i_y=1,34 \text{ cm}$	

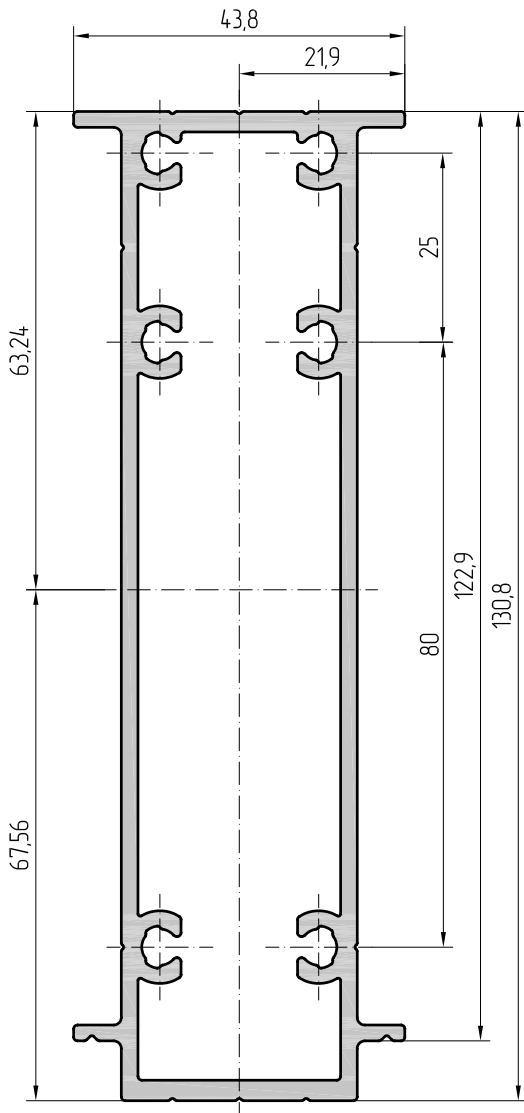
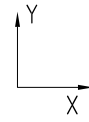

Scale 1:1		Reinforced profile 130,8 mm	
AYPC.F50.3306	Article	Central moments of inertia	
2516 kg	Theoretical weight 1 m	Jx=193,07 cm <sup>4</sup>	Jy=16,69 cm <sup>4</sup>
372,7 mm	External perimeter	Moments of resistance	
9,317 cm <sup>2</sup>	Cross section area	Wx=28,58 cm <sup>3</sup>	Wy=7,62 cm <sup>3</sup>
		Radius of inertia	
		ix=4,55 cm	iy=1,79 cm

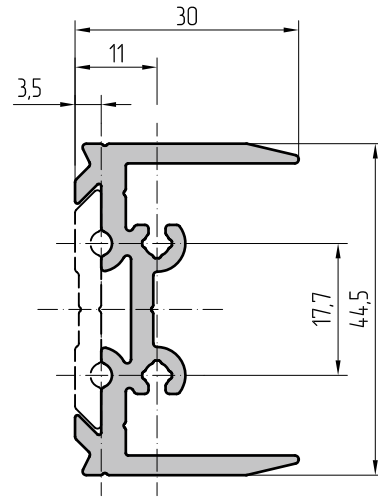
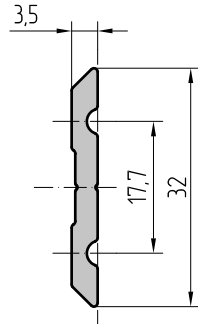

Scale 1:1	Jet nut sliding profile
AYPC.F50.0402	Article
0,247 kg	Theoretical weight 1 m
70,4 mm	External perimeter
0,913 cm <sup>2</sup>	Cross section area

Scale 1:1	Jet nut for transom bar
AYPC.F50.0403	Article
0,919 kg	Theoretical weight 1 m
260,8 mm	External perimeter
3,404 cm <sup>2</sup>	Cross section area

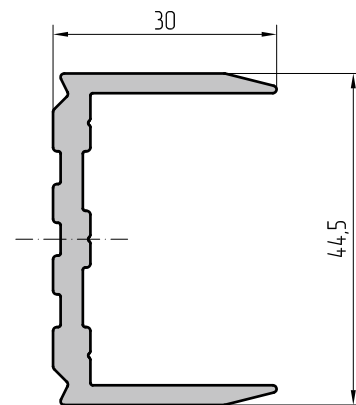
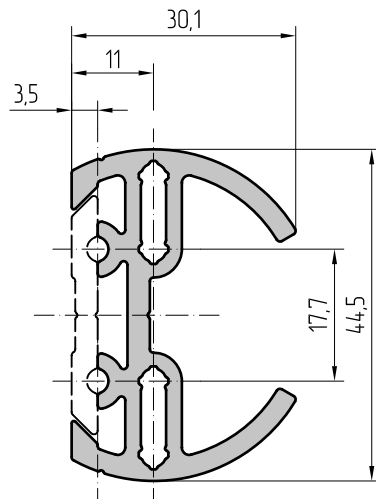

Scale 1:1	Jet nut for transom bar
AYPC.F50.0404	Article
1,050 kg	Theoretical weight 1 m
240,8 mm	External perimeter
3,887 cm <sup>2</sup>	Cross section area

Scale 1:1	Jet nut for transom bar
AYPC.F50.0405	Article
0,809 kg	Theoretical weight 1 m
201,7 mm	External perimeter
2,998 cm <sup>2</sup>	Cross section area

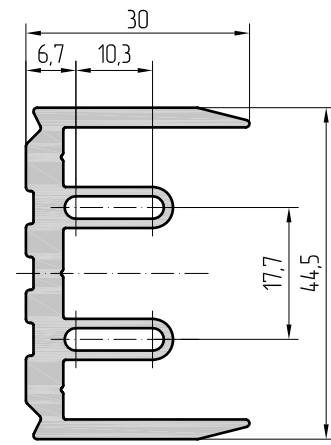
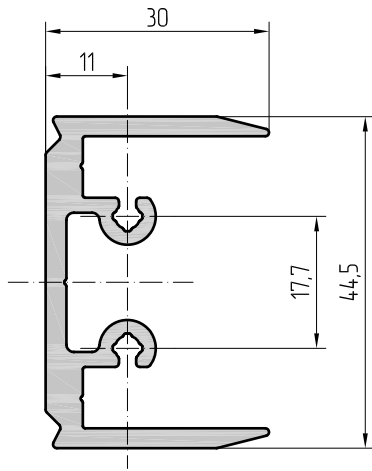

Scale 1:1	Jet nut for transom bar
AYPC.F50.0410	Article
0,959 kg	Theoretical weight 1 m
264,1 mm	External perimeter
3,553 cm <sup>2</sup>	Cross section area

Scale 1:1	Jet nut for transom bar
AYPC.F50.0412	Article
1,069 kg	Theoretical weight 1 m
252,9 mm	External perimeter
3,959 cm <sup>2</sup>	Cross section area

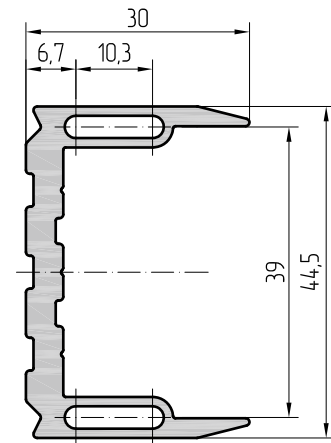
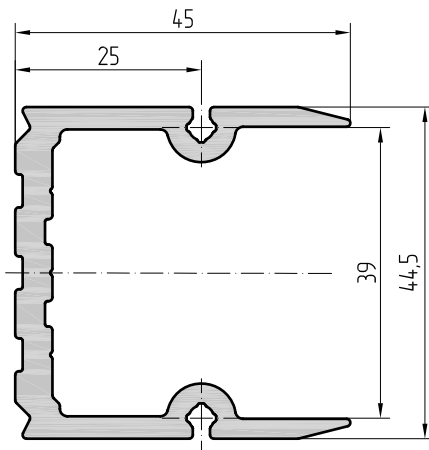

Scale 1:1	Jet nut for transom bar
AYPC.F50.0413	Article
1,212 kg	Theoretical weight 1 m
287,2 mm	External perimeter
4,488 cm <sup>2</sup>	Cross section area

Scale 1:1	Jet nut for transom bar
AYPC.F50.0414	Article
0,847 kg	Theoretical weight 1 m
199,1 mm	External perimeter
3,139 cm <sup>2</sup>	Cross section area

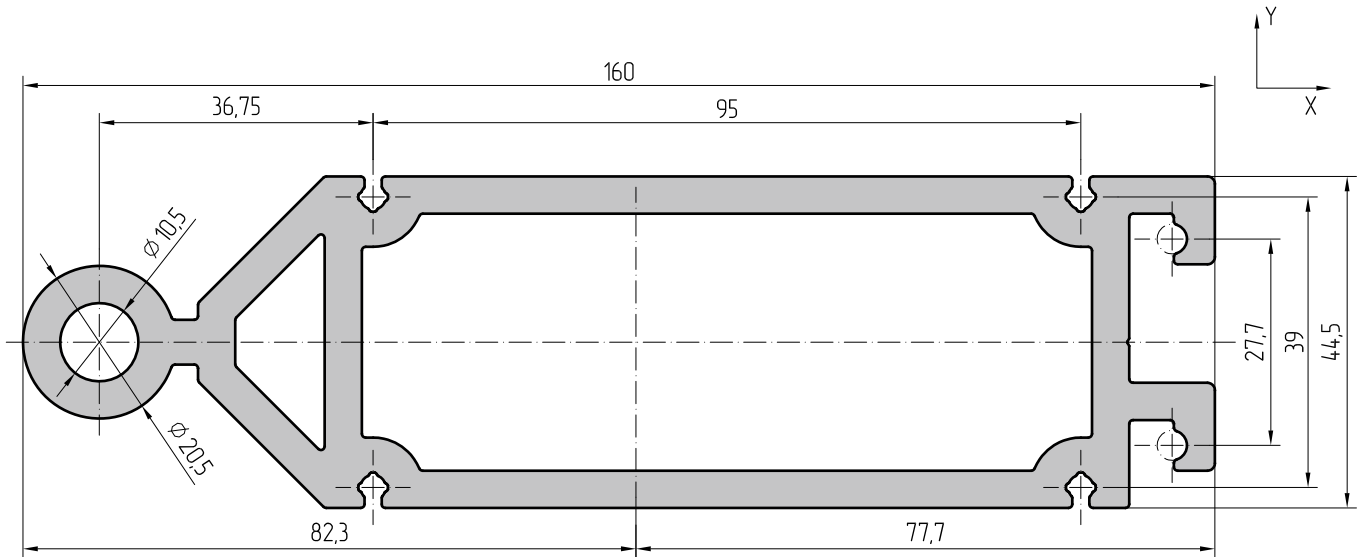

Scale 1:1		Jet nut for mullion curve	
AYPC.F50.0406	Article	Central moments of inertia	
5,862 kg	Theoretical weight 1 m	Jx=54,18 cm <sup>4</sup>	Jy=522,96 cm <sup>4</sup>
488,7 mm	External perimeter	Moments of resistance	
21,711 cm <sup>2</sup>	Cross section area	Wx=24,35 cm <sup>3</sup>	Wy=63,54 cm <sup>3</sup>
		Radius of inertia	
		ix=1,58 cm	iy=4,91 cm

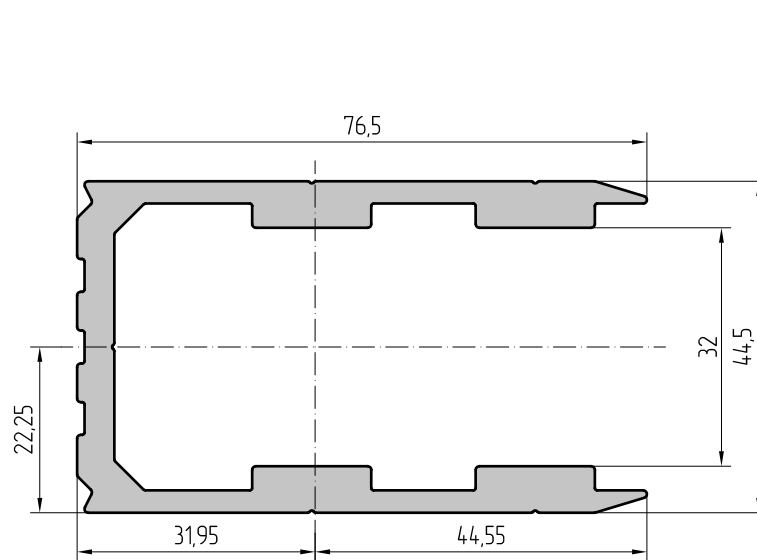

Scale 1:1		Jet nut for mullion curve	
AYPC.F50.0407	Article	Central moments of inertia	
2,250 kg	Theoretical weight 1 m	Jx=27,85 cm <sup>4</sup>	Jy=46,22 cm <sup>4</sup>
4,03,7 mm	External perimeter	Moments of resistance	
8,334 cm <sup>2</sup>	Cross section area	Wx=6,3 cm <sup>3</sup>	Wy=20,8 cm <sup>3</sup>
		Radius of inertia	
		ix=1,83 cm	iy=2,35 cm



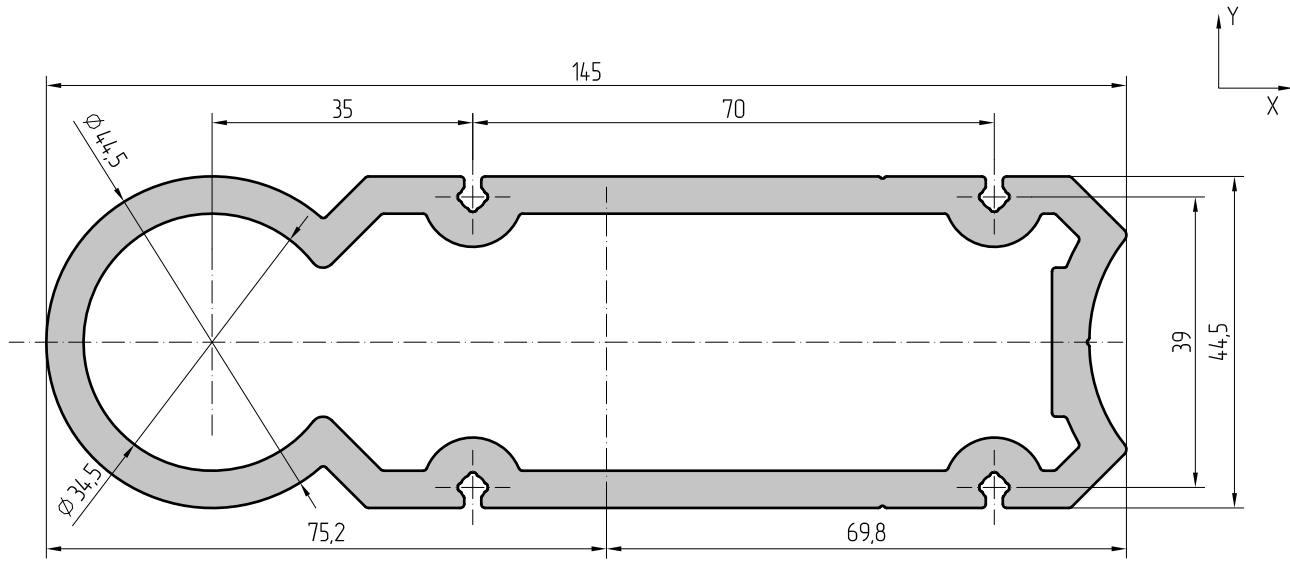

Scale 11		Jet nut for mullion curve	
AYPC.F50.0408	Article	Central moments of inertia	
5,006 kg	Theoretical weight 1 m	Jx=55,62 cm <sup>4</sup>	Jy=383,37 cm <sup>4</sup>
399,3 mm	External perimeter	Moments of resistance	
18,541 cm <sup>2</sup>	Cross section area	Wx=25,00 cm <sup>3</sup>	Wy=50,98 cm <sup>3</sup>
		Radius of inertia	
		ix=1,73 cm	iy=4,55 cm

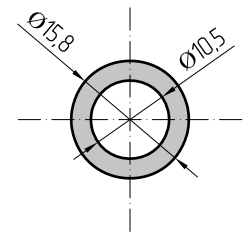
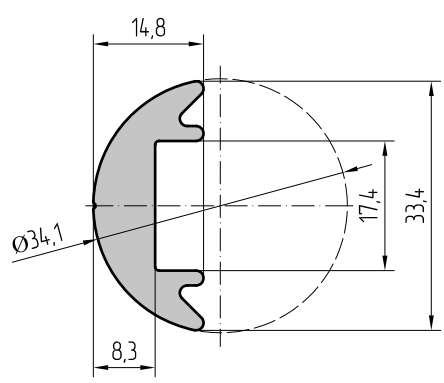

Scale 11		Jet nut (washer)	
AYPC.F50.0409	Article		
0,666 kg	Theoretical weight 1 m		
100,6 mm	External perimeter		
2,467 cm <sup>2</sup>	Cross section area		

Scale 11		Jet nut (bush)	
AYPC.F50.0416	Article		
0,296 kg	Theoretical weight 1 m		
49,6 mm	External perimeter		
1,096 cm <sup>2</sup>	Cross section area		

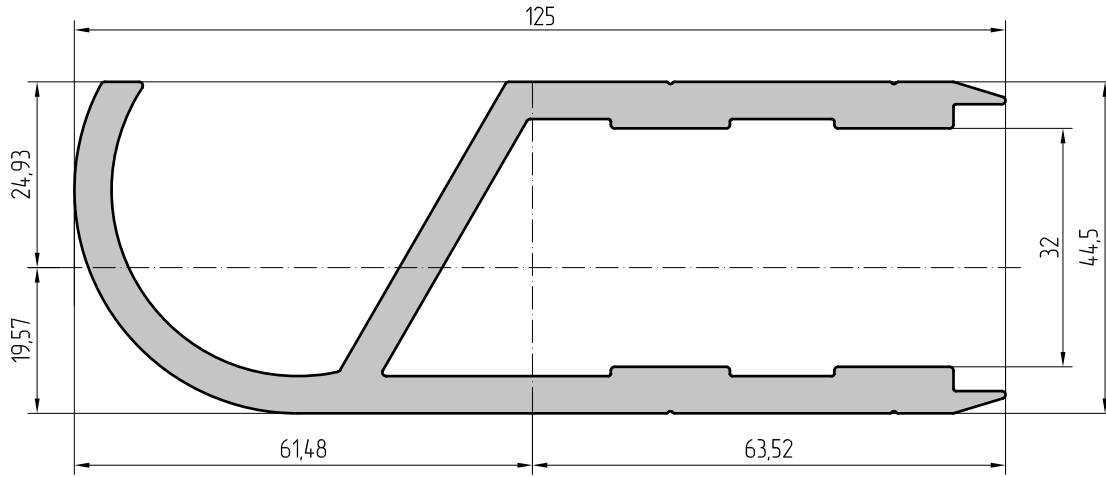

Scale 1:1		Jet nut for transom bar	
AYPC.F50.6005	Article	Central moments of inertia	
3,634 kg	Theoretical weight 1 m	$J_x=39,15 \text{ cm}^4$	$J_y=168,94 \text{ cm}^4$
535,4 mm	External perimeter	Moments of resistance	
13,458 cm <sup>2</sup>	Cross section area	$W_x=15,70 \text{ cm}^3$	$W_y=26,60 \text{ cm}^3$
		Radius of inertia	
		$i_x=1,70 \text{ cm}$	$i_y=3,54 \text{ cm}$

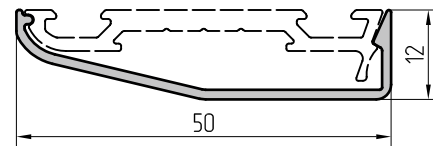
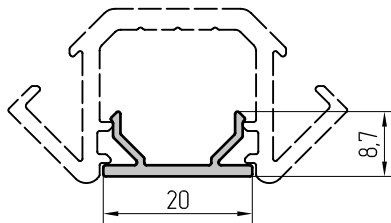

Scale 1:1		Decorative cover cap 8,7 mm	
AYPC.F50.0501	Article		
0,132 kg	Theoretical weight 1 m		
75,4 mm	External perimeter		
0,470 cm <sup>2</sup>	Cross section area		

Scale 1:1		Decorative cover cap for inclined surface 12 mm	
AYPC.F50.0502	Article		
0,230 kg	Theoretical weight 1 m		
133,6 mm	External perimeter		
0,852 cm <sup>2</sup>	Cross section area		

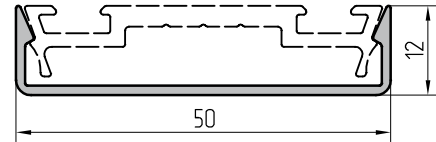
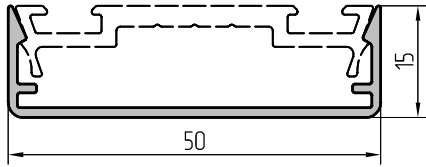

Scale 1:1	Decorative cover cap 15 mm
AYPC.F50.0503	Article
0,286 kg	Theoretical weight 1 m
165,1 mm	External perimeter
1,059 cm <sup>2</sup>	Cross section area

Scale 1:1	Decorative cover cap 12 mm
AYPC.F50.0504	Article
0,251 kg	Theoretical weight 1 m
144,3 mm	External perimeter
0,928 cm <sup>2</sup>	Cross section area



Set together with the clamp bar profile AYPC.F50.0621

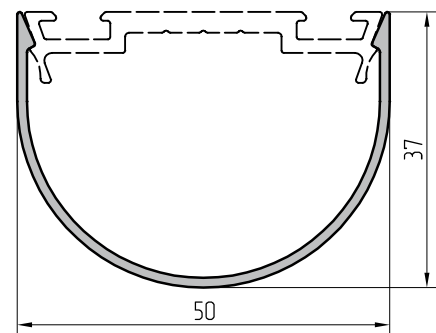
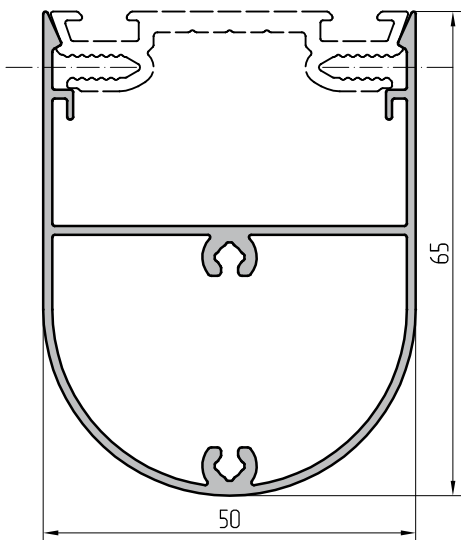

Scale 1:1	Decorative cover cap 37 mm
AYPC.F50.0506	Article
0,359 kg	Theoretical weight 1 m
203,5 mm	External perimeter
1,331 cm <sup>2</sup>	Cross section area

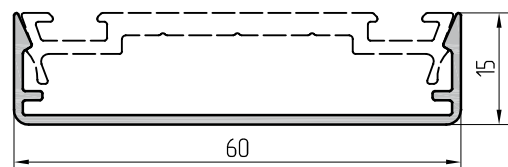

Scale 1:1	Decorative cover cap 65 mm
AYPC.F50.0505	Article
0,827 kg	Theoretical weight 1 m
287,0 mm	External perimeter
3,063 cm <sup>2</sup>	Cross section area

Scale 1:1	Decorative cover cap 15 mm
AYPC.F50.6008	Article
0,321 kg	Theoretical weight 1 m
185,1 mm	External perimeter
1,189 cm <sup>2</sup>	Cross section area



Set together with the clamp bar profile AYP.C.F50.0621

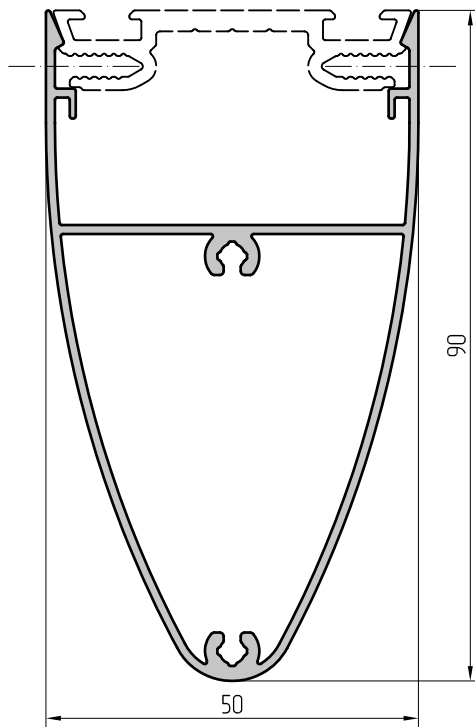

Scale 1:1	Decorative cover cap 95 mm
AYPC.F50.0507	Article
0,939 kg	Theoretical weight 1 m
322,4 mm	External perimeter
3,479 cm <sup>2</sup>	Cross section area



Set together with the clamp bar profile AYP.C.F50.0621

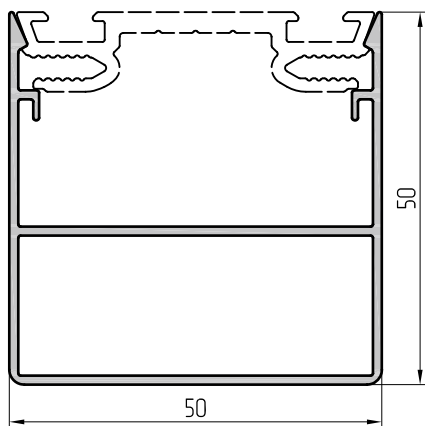

Scale 1:1	Decorative cover cap 50 mm
AYPC.F50.0508	Article
0,670 kg	Theoretical weight 1 m
276,8 mm	External perimeter
2,473 cm <sup>2</sup>	Cross section area



Set together with the clamp bar profile AYP.C.F50.0621

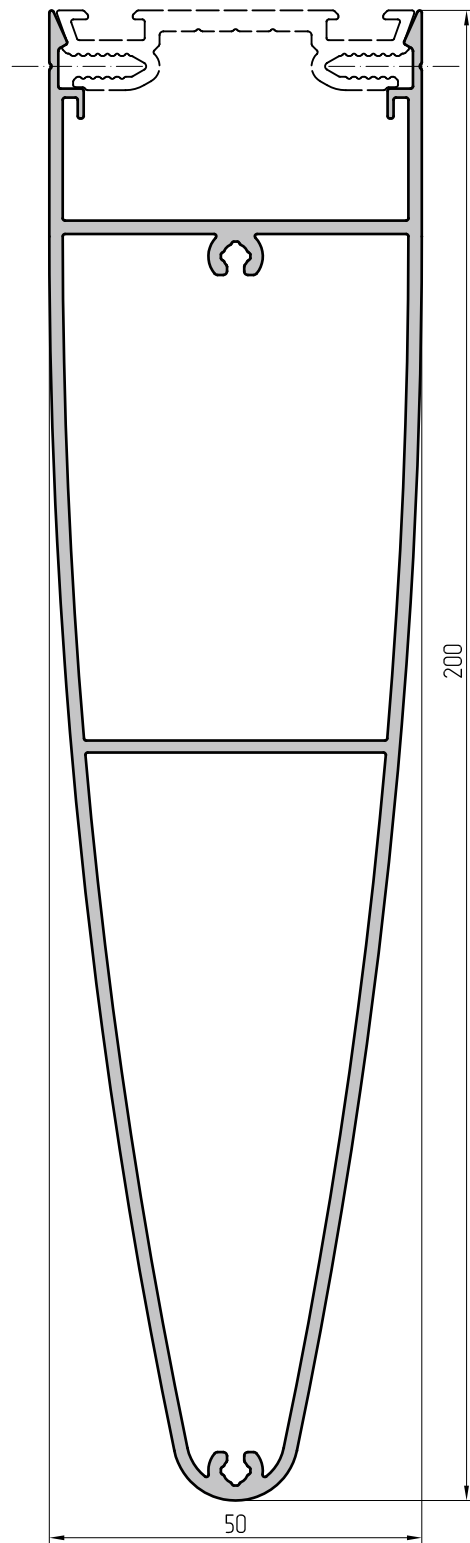

Scale 1:1	Decorative cover cap 200 mm
AYPC.F50.0509	Article
2,515 kg	Theoretical weight 1 m
539,5 mm	External perimeter
9,283 cm <sup>2</sup>	Cross section area



Set together with the clamp bar profile AYPC.F50.0621

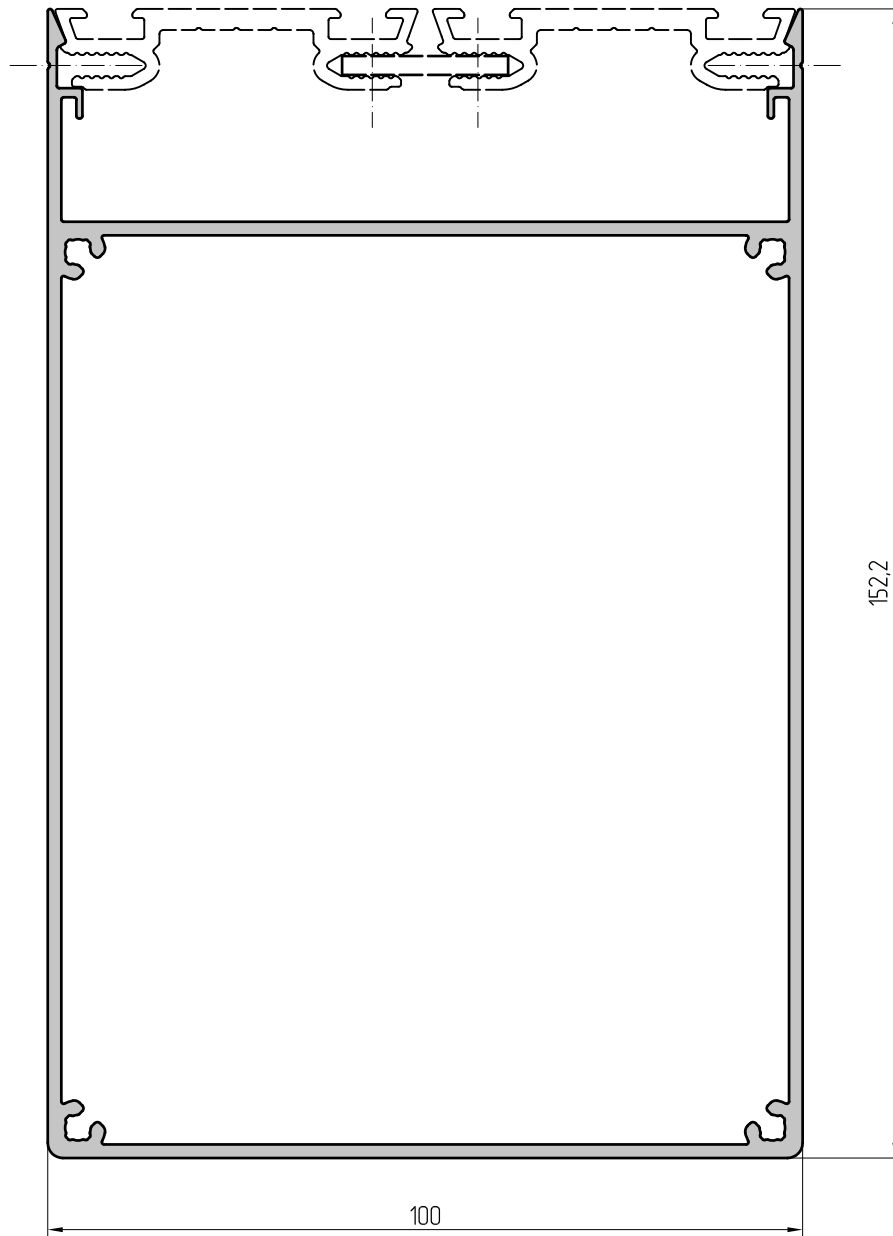

Scale 1:1	Decorative cover cap 152 mm
AYPC.F50.0510	Article
2,570 kg	Theoretical weight 1 m
580,3 mm	External perimeter
9,506 cm <sup>2</sup>	Cross section area

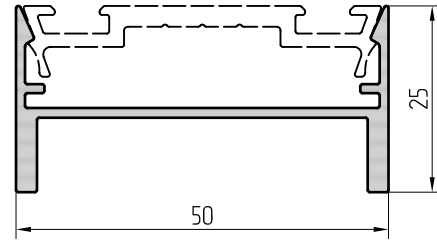
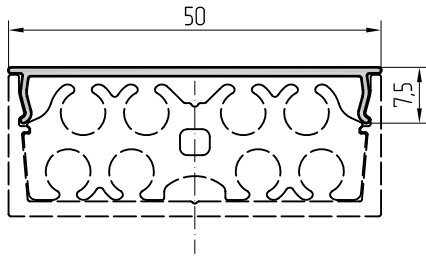

Scale 1:1	Decorative cover cap 7,5 mm	
AYPC.F50.0511	Article	
0,186 kg	Theoretical weight 1 m	
127,4 mm	External perimeter	
0,69 cm <sup>2</sup>	Cross section area	

Scale 1:1	Decorative cover cap 25 mm	
AYPC.F50.0515	Article	
0,442 kg	Theoretical weight 1 m	
206,0 mm	External perimeter	
1,636 cm <sup>2</sup>	Cross section area	



Set together with the clamp bar profile AYPC.F50.0621



Set together with the clamp bar profile AYPC.F50.0621

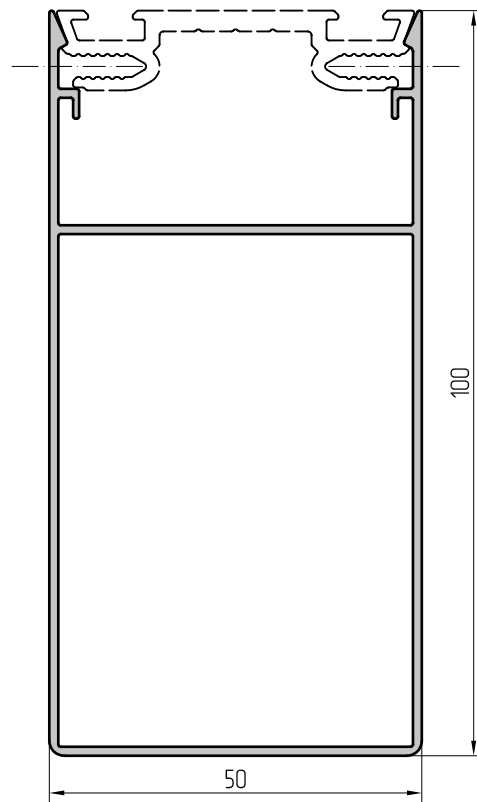
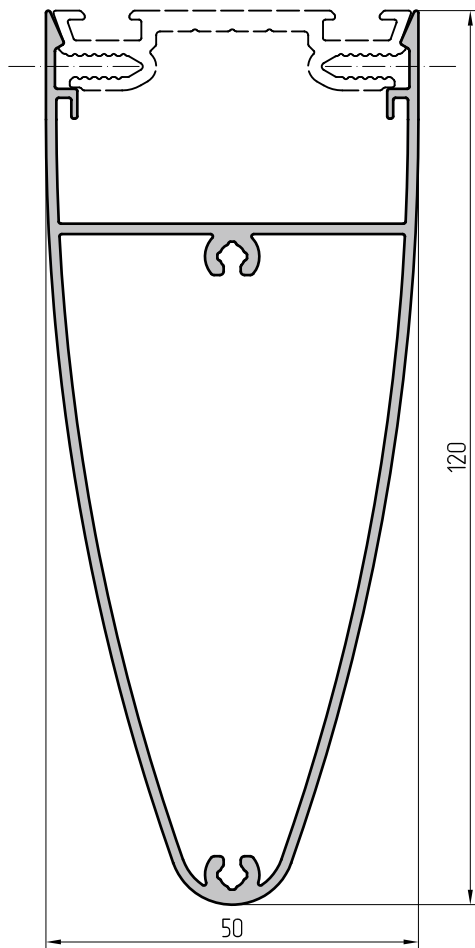

Scale 1:1	Decorative cover cap 120 mm	
AYPC.F50.0520	Article	
1,274 kg	Theoretical weight 1 m	
380,8 mm	External perimeter	
4,718 cm <sup>2</sup>	Cross section area	

Scale 1:1	Decorative cover cap 100 mm	
AYPC.F50.0521	Article	
0,992 kg	Theoretical weight 1 m	
376,7 mm	External perimeter	
3,673 cm <sup>2</sup>	Cross section area	

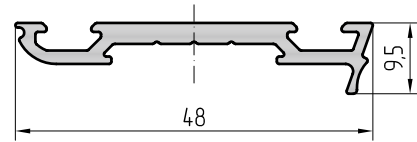
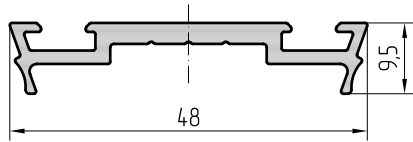

Scale 1:1	Clamp bar profile 9,5 mm
AYPC.F50.0601	Article
0,397 kg	Theoretical weight 1 m
151,2 mm	External perimeter
1,471 cm <sup>2</sup>	Cross section area

Scale 1:1	Clamp bar profile for inclined surface 9,5 mm
AYPC.F50.0602	Article
0,373 kg	Theoretical weight 1 m
141,6 mm	External perimeter
1,383 cm <sup>2</sup>	Cross section area

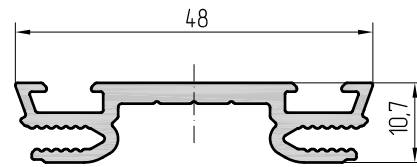
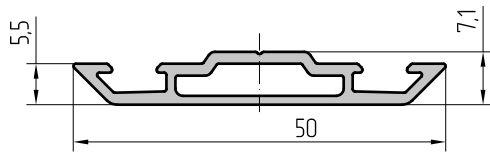

Scale 1:1	Clamp bar profile 5,5 mm
AYPC.F50.0620	Article
0,356 kg	Theoretical weight 1 m
129,2 mm	External perimeter
1,320 cm <sup>2</sup>	Cross section area

Scale 1:1	Clamp bar profile 10,7 mm
AYPC.F50.0621	Article
0,512 kg	Theoretical weight 1 m
195,7 mm	External perimeter
1,893 cm <sup>2</sup>	Cross section area

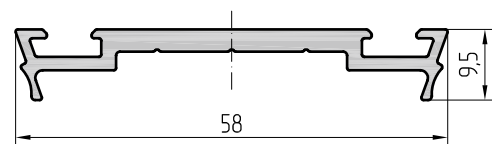
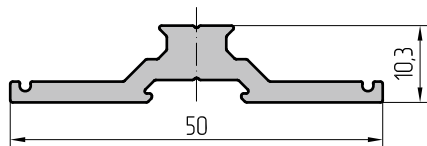

Scale 1:1	Clamp bar profile 10,3 mm
AYPC.F50.0622	Article
0,505 kg	Theoretical weight 1 m
128,7 mm	External perimeter
1,870 cm <sup>2</sup>	Cross section area

Scale 1:1	Clamp bar profile 9,5 mm
AYPC.F50.6009	Article
0,489 kg	Theoretical weight 1 m
170,8 mm	External perimeter
1,183 cm <sup>2</sup>	Cross section area

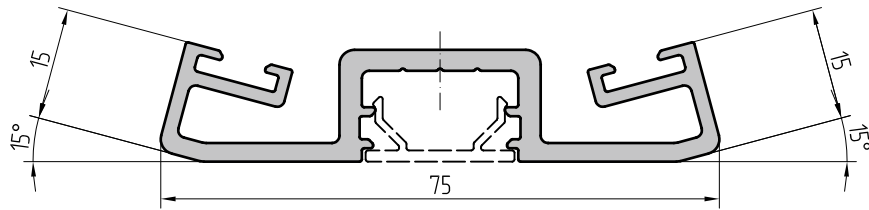

Scale 1:1	Clamp bar profile for bilateral angle +15°
AYPC.F50.0605	Article
1,063 kg	Theoretical weight 1 m
341,7 mm	External perimeter
3,923 cm <sup>2</sup>	Cross section area

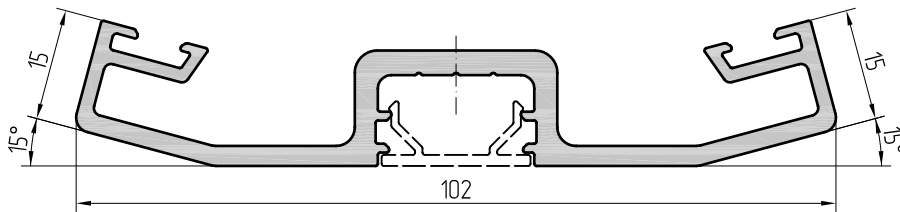

Scale 1:1	Clamp bar profile for bilateral angle +15°
AYPC.F50.0605-01	Article
1,311 kg	Theoretical weight 1 m
389,4 mm	External perimeter
4,854 cm <sup>2</sup>	Cross section area

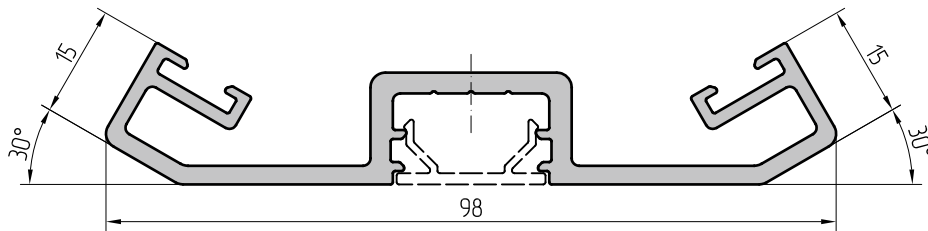

Scale 1:1	Clamp bar profile for bilateral angle +30°
AYPC.F50.0606	Article
1,237 kg	Theoretical weight 1 m
393,1 mm	External perimeter
4,566 cm <sup>2</sup>	Cross section area

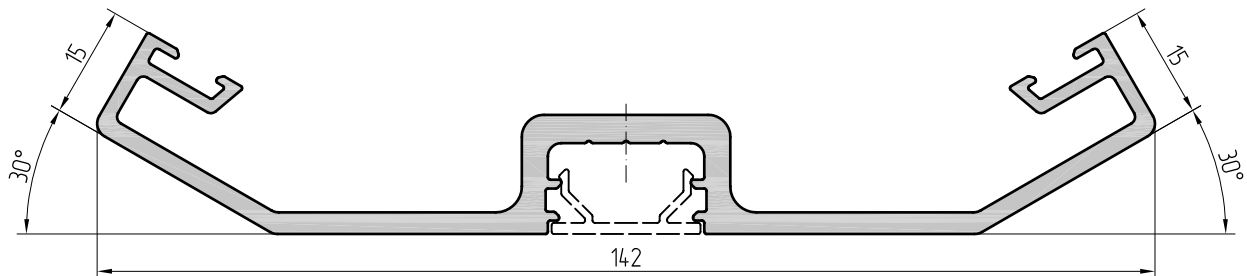

Scale 1:1	Clamp bar profile for bilateral angle +30°
AYPC.F50.0606-01	Article
1,750 kg	Theoretical weight 1 m
481,1 mm	External perimeter
6,481 cm <sup>2</sup>	Cross section area



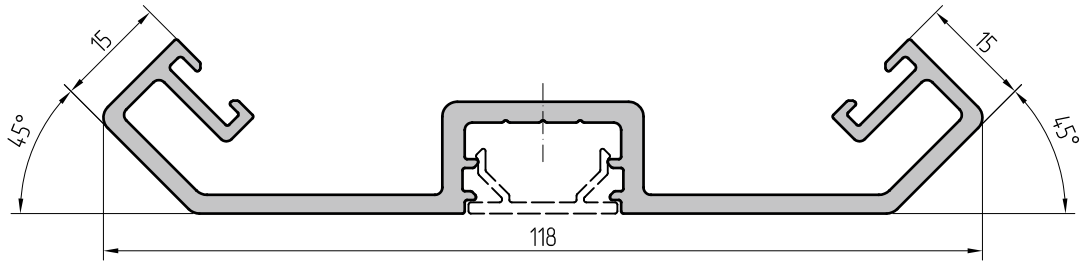

Scale 1:1	Clamp bar profile for bilateral angle +45°
AYPC.F50.0607	Article
1,419 kg	Theoretical weight 1 m
446,6 mm	External perimeter
5,238 cm <sup>2</sup>	Cross section area

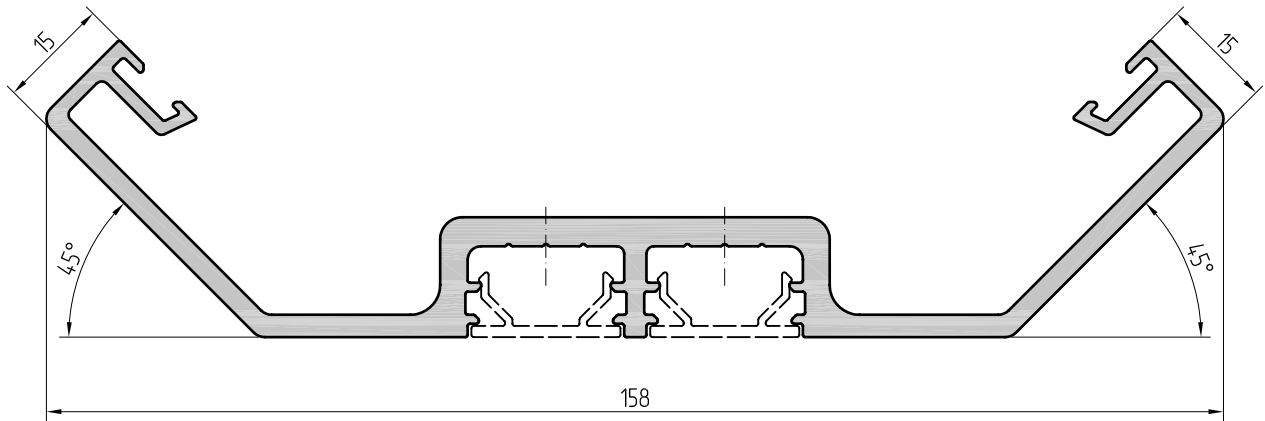

Scale 1:1	Clamp bar profile for bilateral angle +45°
AYPC.F50.0607-01	Article
2,234 kg	Theoretical weight 1 m
579,2 mm	External perimeter
8,274 cm <sup>2</sup>	Cross section area

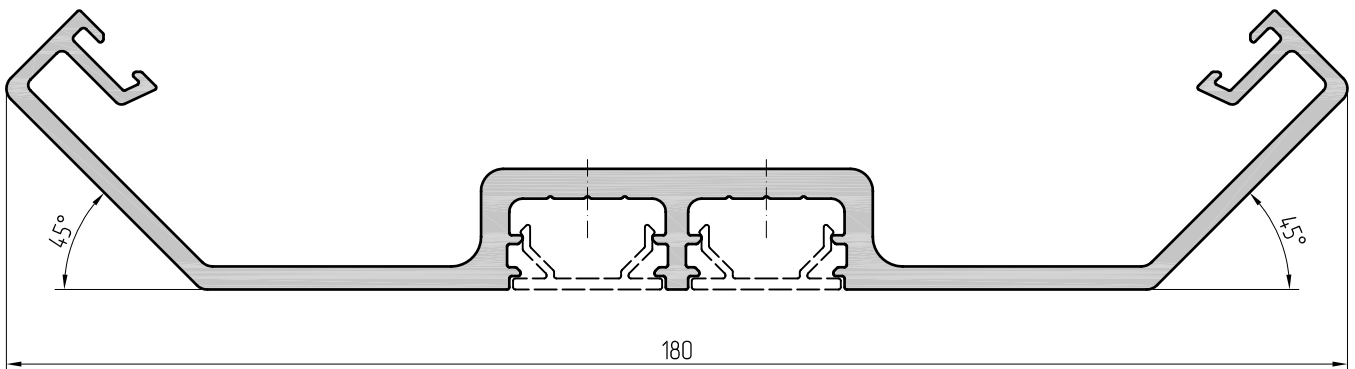

Scale 1:1	Clamp bar profile for bilateral angle +45°
AYPC.F50.0607-02	Артикул профиля
2,429 kg	Теоретическая масса 1 п.м
618,9 mm	Внешний периметр
8,995 cm <sup>2</sup>	Площадь сечения

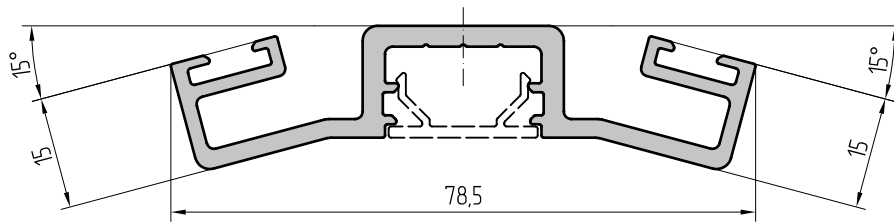

Scale 1:1	Clamp bar profile for bilateral angle $-15^\circ$
AYPC.F50.0608	Article
1,044 kg	Theoretical weight 1 m
335,9 mm	External perimeter
3,851 cm <sup>2</sup>	Cross section area

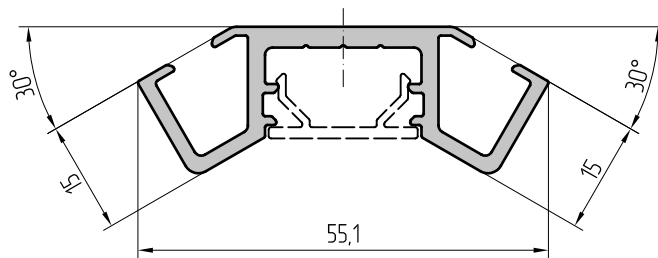

Scale 1:1	Clamp bar profile for bilateral angle $-30^\circ$
AYPC.F50.0609	Article
0,656 kg	Theoretical weight 1 m
235,2 mm	External perimeter
2,422 cm <sup>2</sup>	Cross section area

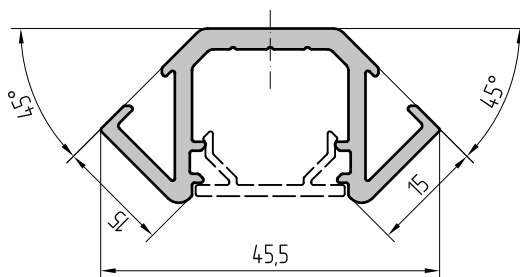

Scale 1:1	Clamp bar profile for bilateral angle $-45^\circ$
AYPC.F50.0610	Article
0,622 kg	Theoretical weight 1 m
209,9 mm	External perimeter
2,294 cm <sup>2</sup>	Cross section area

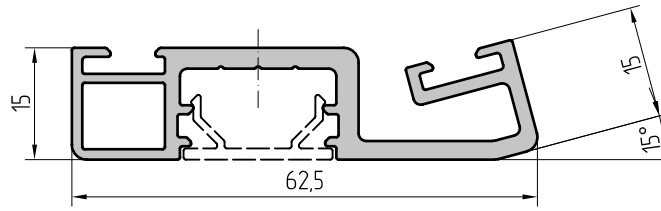

Scale 1:1	Clamp bar profile for unilateral angle +15°
AYPC.F50.0611	Article
0,845 kg	Theoretical weight 1 m
268,1 mm	External perimeter
3,131 cm <sup>2</sup>	Cross section area

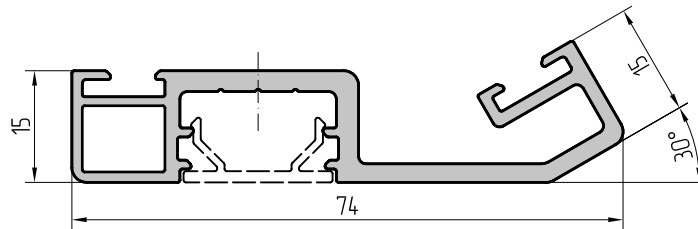

Scale 1:1	Clamp bar profile for unilateral angle +30°
AYPC.F50.0612	Article
0,932 kg	Theoretical weight 1 m
293,8	External perimeter
3,452 cm <sup>2</sup>	Cross section area

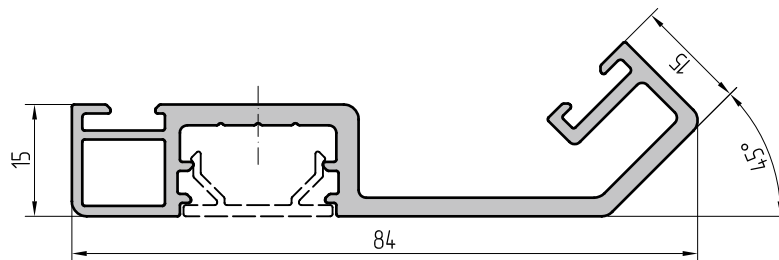

Scale 1:1	Clamp bar profile for unilateral angle +45°
AYPC.F50.0613	Article
1,023 kg	Theoretical weight 1 m
320,5mm	External perimeter
3,788 cm <sup>2</sup>	Cross section area

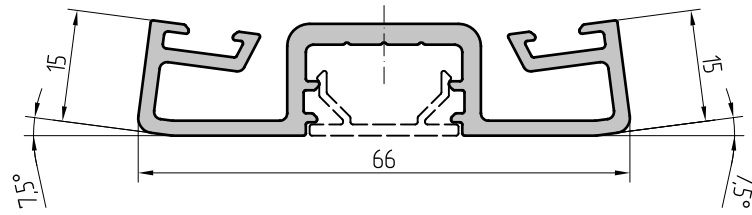

Scale 1:1	Clamp bar profile for bilateral angle +7,5°
AYPC.F50.0614	Article
0,894 kg	Theoretical weight 1 m
318,5 mm	External perimeter
3,313 cm <sup>2</sup>	Cross section area

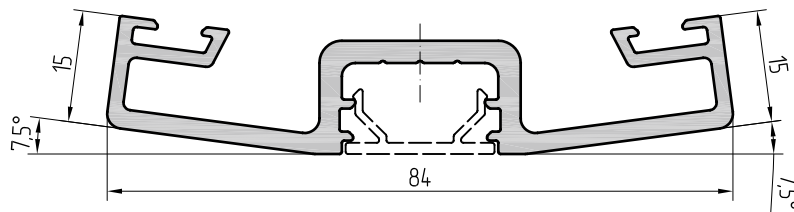

Scale 1:1	Clamp bar profile for bilateral angle +7,5°
AYPC.F50.0614-01	Article
1,138 kg	Theoretical weight 1 m
351,2 mm	External perimeter
4,214 cm <sup>2</sup>	Cross section area

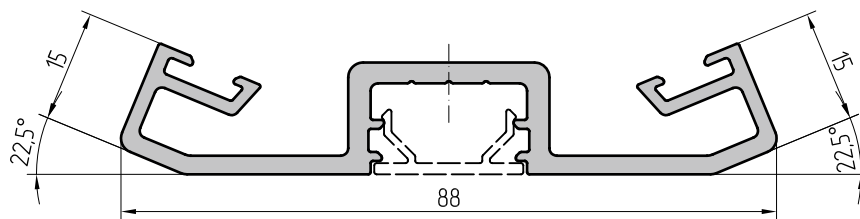

Scale 1:1	Clamp bar profile for bilateral angle +22,5°
AYPC.F50.0615	Article
1,141 kg	Theoretical weight 1 m
364,2 mm	External perimeter
4,227 cm <sup>2</sup>	Cross section area

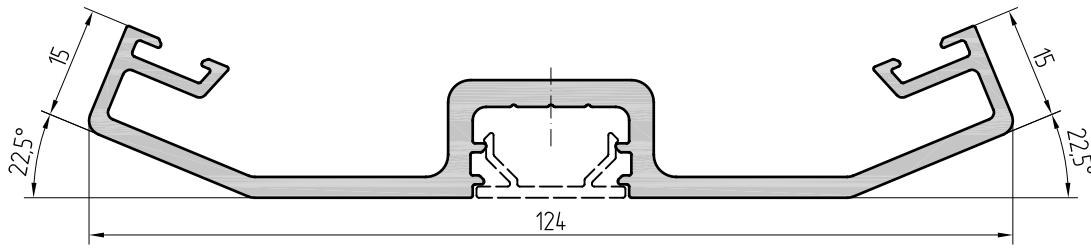

Scale 1:1	Clamp bar profile for bilateral angle +22,5°
AYPC.F50.0615-01	Article
1539 kg	Theoretical weight 1 m
438,0 mm	External perimeter
5,700 cm <sup>2</sup>	Cross section area

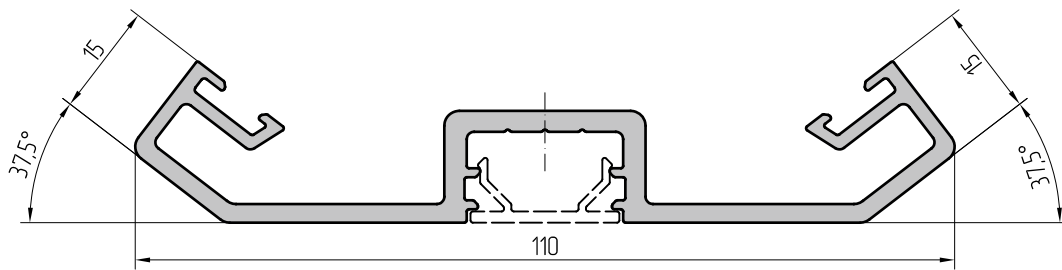

Scale 1:1	Clamp bar profile for bilateral angle +37,5°
AYPC.F50.0616	Article
1322 kg	Theoretical weight 1 m
417,8 mm	External perimeter
4,898 cm <sup>2</sup>	Cross section area

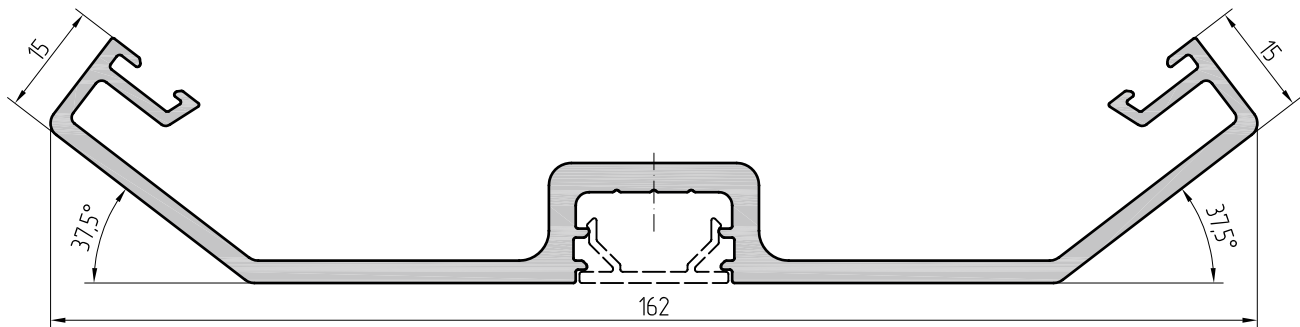

Scale 1:1	Clamp bar profile for bilateral angle +37,5°
AYPC.F50.0616-01	Article
2,004 kg	Theoretical weight 1 m
533,3 mm	External perimeter
7,423 cm <sup>2</sup>	Cross section area

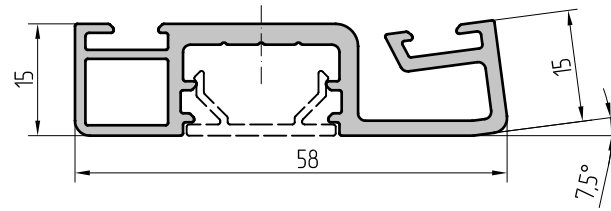

Scale 1:1	Clamp bar profile for unilateral angle +7,5°
AYPC.F50.0617	Article
0,845 kg	Theoretical weight 1 m
268,1 mm	External perimeter
3,131 cm <sup>2</sup>	Cross section area

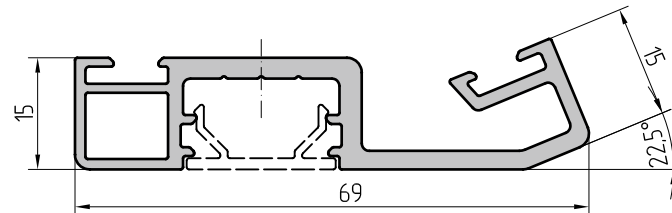

Scale 1:1	Clamp bar profile for unilateral angle +22,5°
AYPC.F50.0618	Article
0,886 kg	Theoretical weight 1 m
318,9	External perimeter
3,283 cm <sup>2</sup>	Cross section area

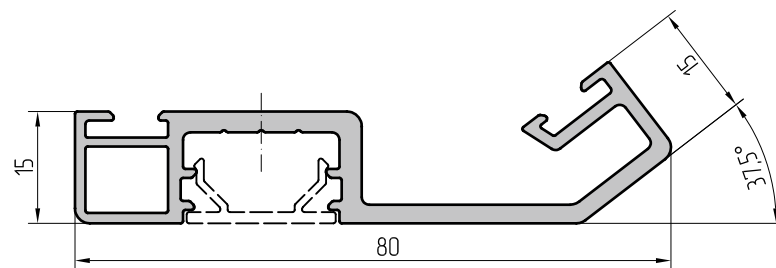

Scale 1:1	Clamp bar profile for unilateral angle +37,5°
AYPC.F50.0619	Article
0,977 kg	Theoretical weight 1 m
345,6mm	External perimeter
3,618 cm <sup>2</sup>	Cross section area

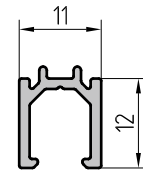
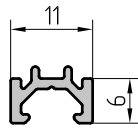

Scale 1:1	Auxiliary profile, distance adapter 6 mm
AYPC.F50.0701	Article
0,095 kg	Theoretical weight 1 m
52,7 mm	External perimeter
0,350 cm <sup>2</sup>	Cross section area

Scale 1:1	Auxiliary profile, distance adapter 12 mm
AYPC.F50.0702	Article
0,140 kg	Theoretical weight 1 m
76,7 mm	External perimeter
0,517 cm <sup>2</sup>	Cross section area

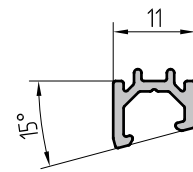
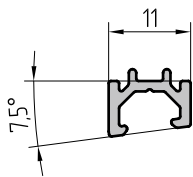

Scale 1:1	Auxiliary profile, angle adapter +7,5°
AYPC.F50.0712	Article
0,100 kg	Theoretical weight 1 m
55,9 mm	External perimeter
0,372 cm <sup>2</sup>	Cross section area

Scale 1:1	Auxiliary profile, angle adapter +15°
AYPC.F50.0705	Article
0,107 kg	Theoretical weight 1 m
59,6 mm	External perimeter
0,397 cm <sup>2</sup>	Cross section area

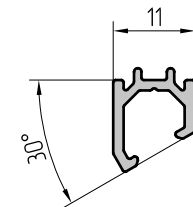
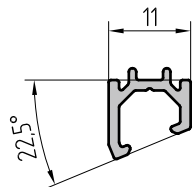

Scale 1:1	Auxiliary profile, angle adapter +22,5°
AYPC.F50.0713	Article
0,115 kg	Theoretical weight 1 m
63,9 mm	External perimeter
0,426 cm <sup>2</sup>	Cross section area

Scale 1:1	Auxiliary profile, angle adapter +30°
AYPC.F50.0706	Article
0,125 kg	Theoretical weight 1 m
68,7 mm	External perimeter
0,460 cm <sup>2</sup>	Cross section area

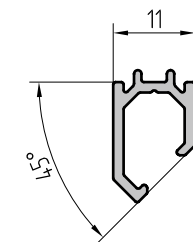
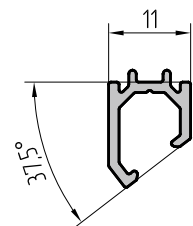

Scale 1:1	Auxiliary profile, angle adapter +37,5°
AYPC.F50.0714	Article
0,135 kg	Theoretical weight 1 m
74,4 mm	External perimeter
0,500 cm <sup>2</sup>	Cross section area

Scale 1:1	Auxiliary profile, angle adapter +45°
AYPC.F50.0707	Article
0,148 kg	Theoretical weight 1 m
81,4 mm	External perimeter
0,548 cm <sup>2</sup>	Cross section area

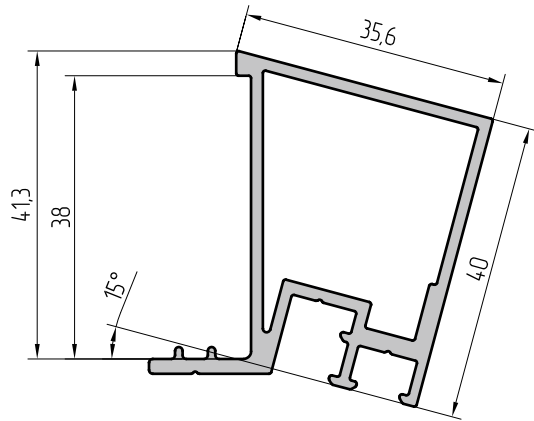

Scale 1:1	Auxiliary profile, angle adapter -15°
AYPC.F50.0708	Article
0,819 kg	Theoretical weight 1 m
214,0 mm	External perimeter
3,021 cm <sup>2</sup>	Cross section area

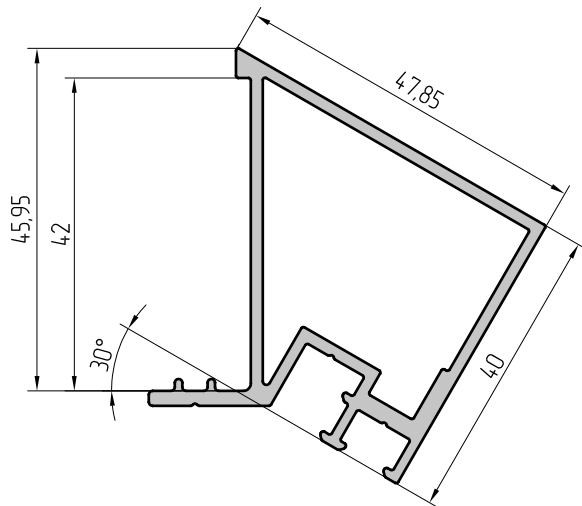

Scale 1:1	Auxiliary profile, angle adapter -30°
AYPC.F50.0709	Article
0,883 kg	Theoretical weight 1 m
229,6 mm	External perimeter
3,259 cm <sup>2</sup>	Cross section area

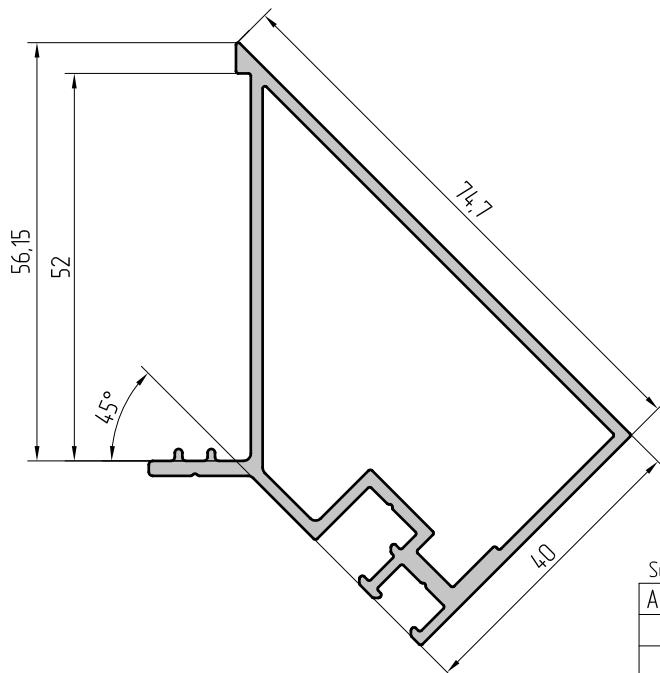

Scale 1:1	Auxiliary profile, angle adapter -45°
AYPC.F50.0710	Article
1,078 kg	Theoretical weight 1 m
276,4 mm	External perimeter
3,977 cm <sup>2</sup>	Cross section area



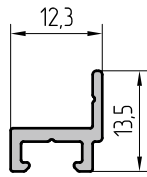

Scale 11	Auxiliary profile, adapter 13,5 mm
AYPC.F50.0711	Article
0,122 kg	Theoretical weight 1 m
61,6 mm	External perimeter
0,451 cm <sup>2</sup>	Cross section area

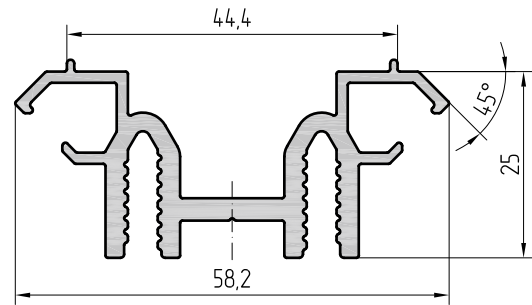

Scale 11	Auxiliary profile, angle adapter +45°
AYPC.F50.0715	Article
0,935 kg	Theoretical weight 1 m
318,0 mm	External perimeter
3,464 cm <sup>2</sup>	Cross section area

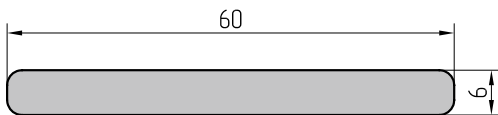

Scale 11	Auxiliary profile, flat bar 60x6 mm
AYPC.F50.0721	Article
0,963 kg	Theoretical weight 1 m
128,6 mm	External perimeter
3,566 cm <sup>2</sup>	Cross section area

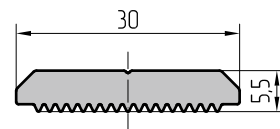

Scale 11	Auxiliary profile, washer 30x5,5 mm
AYPC.F50.0722	Article
0,381 kg	Theoretical weight 1 m
85,2 mm	External perimeter
1,412 cm <sup>2</sup>	Cross section area

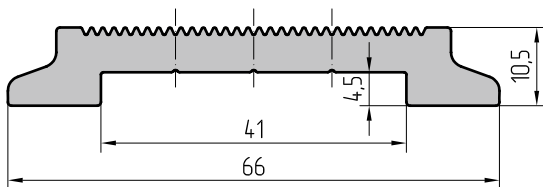

Scale 11	Auxiliary profile, plate 66x10,5 mm
AYPC.F50.0724	Article
1,100 kg	Theoretical weight 1 m
190,8 mm	External perimeter
4,074 cm <sup>2</sup>	Cross section area

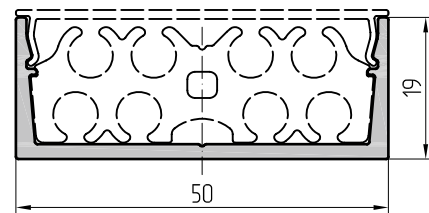

Scale 11	Auxiliary profile, cable channel 20 mm
AYPC.F50.0725	Article
0,450 kg	Theoretical weight 1 m
173,5 mm	External perimeter
1,666 cm <sup>2</sup>	Cross section area

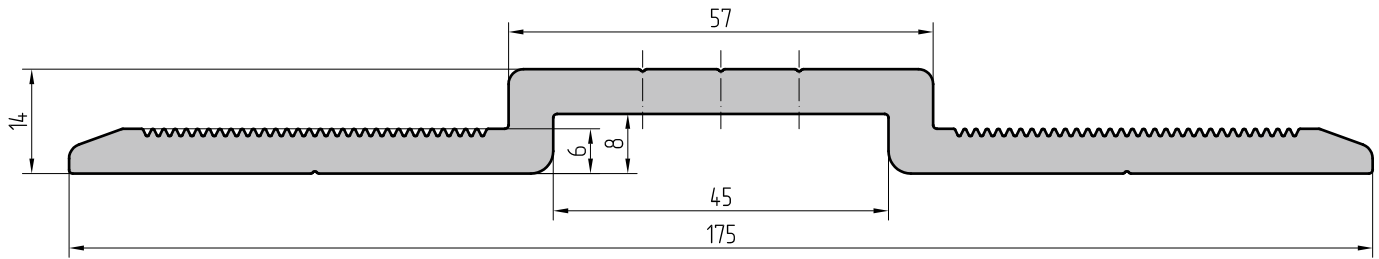

Scale 1:1	Auxiliary profile, plate 170x14 mm
AYPC.F50.0723	Article
2,899 kg	Theoretical weight 1 m
454,6 mm	External perimeter
10,737 cm <sup>2</sup>	Cross section area

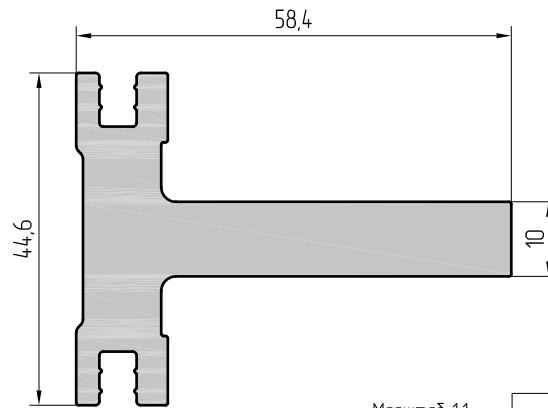

Macramã 1:1	Support profile for glass
AYPC.F50.0818	Article
2,443 kg	Theoretical weight 1 m
236 mm	External perimeter
9,050 cm <sup>2</sup>	Cross section area

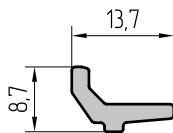

Scale 1:1	Support profile for glass 4-8 mm
AYPC.F50.0801	Article
0,117 kg	Theoretical weight 1 m
39,3 mm	External perimeter
0,431 cm <sup>2</sup>	Cross section area

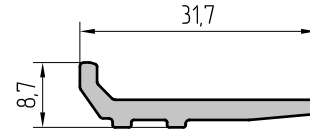
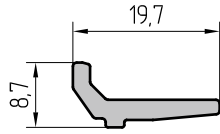

Scale 1:1	Support profile for glass unit 4-8 mm
AYPC.F50.0807	Article
0,116 kg	Theoretical weight 1 m
51,2 mm	External perimeter
0,591 cm <sup>2</sup>	Cross section area

Scale 1:1	Support profile for glass unit 22-26 mm
AYPC.F50.0802	Article
0,255 kg	Theoretical weight 1 m
76,6 mm	External perimeter
0,941 cm <sup>2</sup>	Cross section area

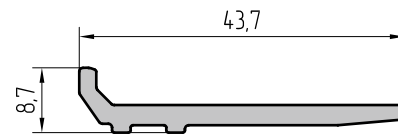
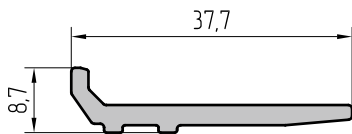

Scale 1:1	Support profile for glass unit 28-32 mm
AYPC.F50.0803	Article
0,299 kg	Theoretical weight 1 m
86,6 mm	External perimeter
1,103 cm <sup>2</sup>	Cross section area

Scale 1:1	Support profile for glass unit 34-38 mm
AYPC.F50.0804	Article
0,343 kg	Theoretical weight 1 m
100,6 mm	External perimeter
1,265 cm <sup>2</sup>	Cross section area

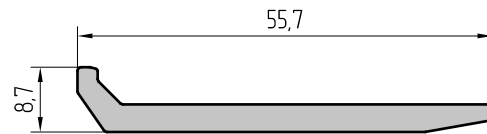
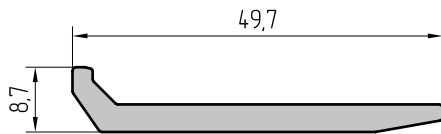

Scale 1:1	Support profile for glass unit 40-44 mm
AYPC.F50.0805	Article
0,500 kg	Theoretical weight 1 m
110,0 mm	External perimeter
1,853 cm <sup>2</sup>	Cross section area

Scale 1:1	Support profile for glass unit 46-50 mm
AYPC.F50.0806	Article
0,560 kg	Theoretical weight 1 m
122,0 mm	External perimeter
2,075 cm <sup>2</sup>	Cross section area

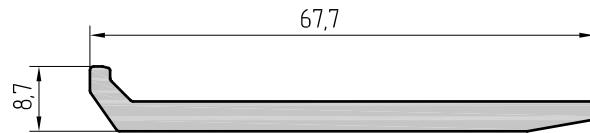
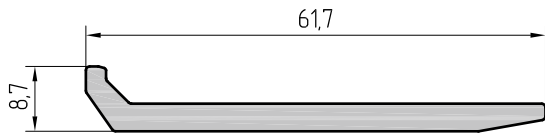

Scale 1:1	Support profile for glass unit 52-56 mm
AYPC.F50.0814	Article
0,620 kg	Theoretical weight 1 m
134,0 mm	External perimeter
2,297 cm <sup>2</sup>	Cross section area

Scale 1:1	Support profile for glass unit 58-62 mm
AYPC.F50.0815	Article
0,730 kg	Theoretical weight 1 m
146,1 mm	External perimeter
2,704 cm <sup>2</sup>	Cross section area

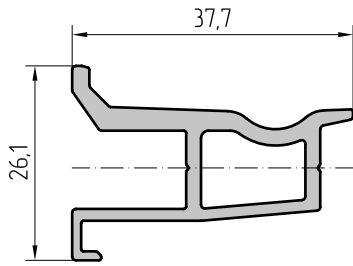

Scale 1:1	Support profile for glass unit 34-38 mm
AYPC.F50.0808	Article
0,561 kg	Theoretical weight 1 m
155,9 mm	External perimeter
2,078 cm <sup>2</sup>	Cross section area



Scale 1:1	Support profile for glass unit 34-38 mm
AYPC.F50.0811	Article
0,246 kg	Theoretical weight 1 m
75,6 mm	External perimeter
0,911 cm <sup>2</sup>	Cross section area

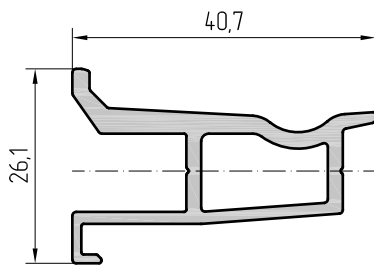

Scale 1:1	Support profile for glass unit 40-44 mm
AYPC.F50.0809	Article
0,597 kg	Theoretical weight 1 m
213,8 mm	External perimeter
2,213 cm <sup>2</sup>	Cross section area

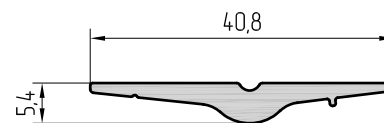

Scale 1:1	Support profile for glass unit 40-44 mm
AYPC.F50.0812	Article
0,290 kg	Theoretical weight 1 m
87,3 mm	External perimeter
1,076 cm <sup>2</sup>	Cross section area

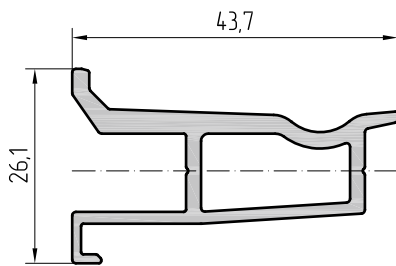

Scale 1:1	Support profile for glass unit 46-50 mm
AYPC.F50.0810	Article
0,634 kg	Theoretical weight 1 m
225,9 mm	External perimeter
2,347 cm <sup>2</sup>	Cross section area

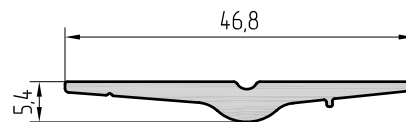

Scale 1:1	Support profile for glass unit 46-50 mm
AYPC.F50.0813	Article
0,332 kg	Theoretical weight 1 m
99,4 mm	External perimeter
1,229 cm <sup>2</sup>	Cross section area

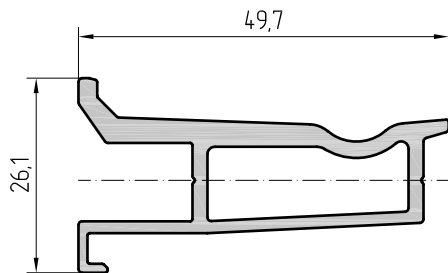

Scale 1:1	Support profile for glass unit 52-56 mm
AYPC.F50.0816	Article
0,746 kg	Theoretical weight 1 m
179,9 mm	External perimeter
2,762 cm <sup>2</sup>	Cross section area

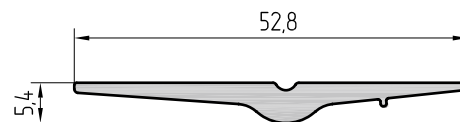

Scale 1:1	Support profile for glass unit 52-56 mm
AYPC.F50.0817	Article
0,360 kg	Theoretical weight 1 m
110,9 mm	External perimeter
1,335 cm <sup>2</sup>	Cross section area

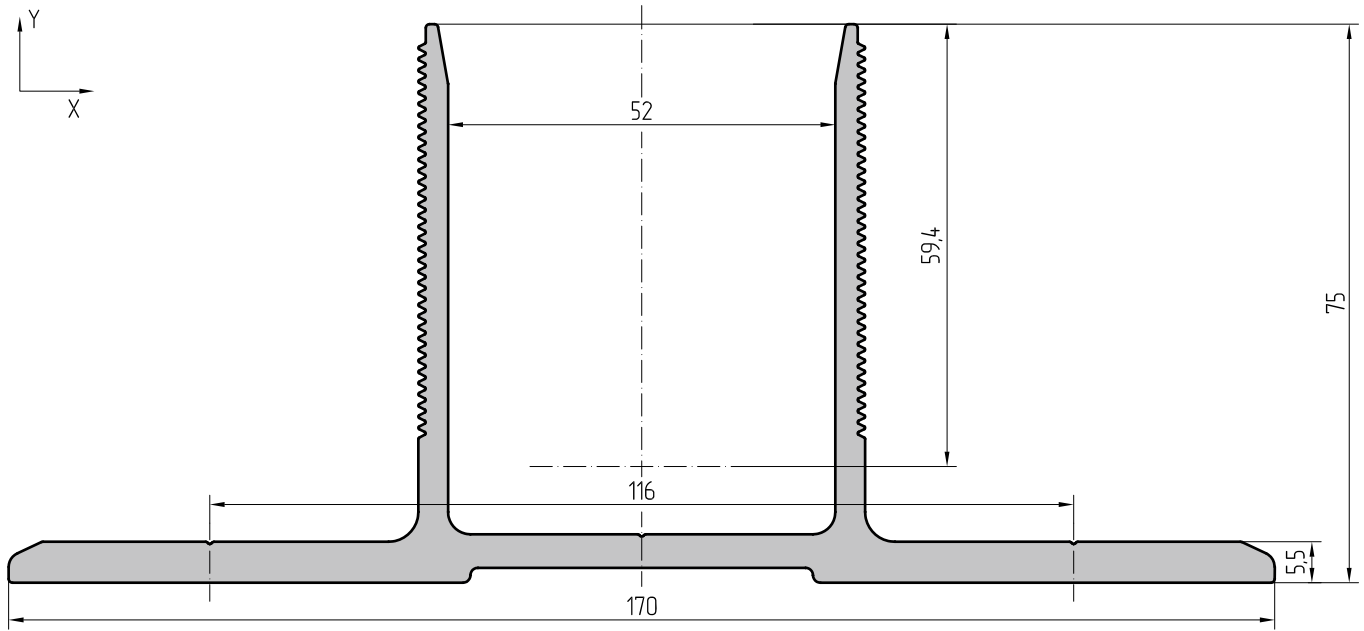

Scale 1:1		Bracket profile 170x75 mm	
AYPC.150.0306	Article	Central moments of inertia	
3,729 kg	Theoretical weight 1 m	Jx=58,77 cm <sup>4</sup>	Jy=256,18 cm <sup>4</sup>
694,7 mm	External perimeter	Moments of resistance	
13,812 cm <sup>2</sup>	Cross section area	Wx=9,89 cm <sup>3</sup>	Wy=30,14 cm <sup>3</sup>

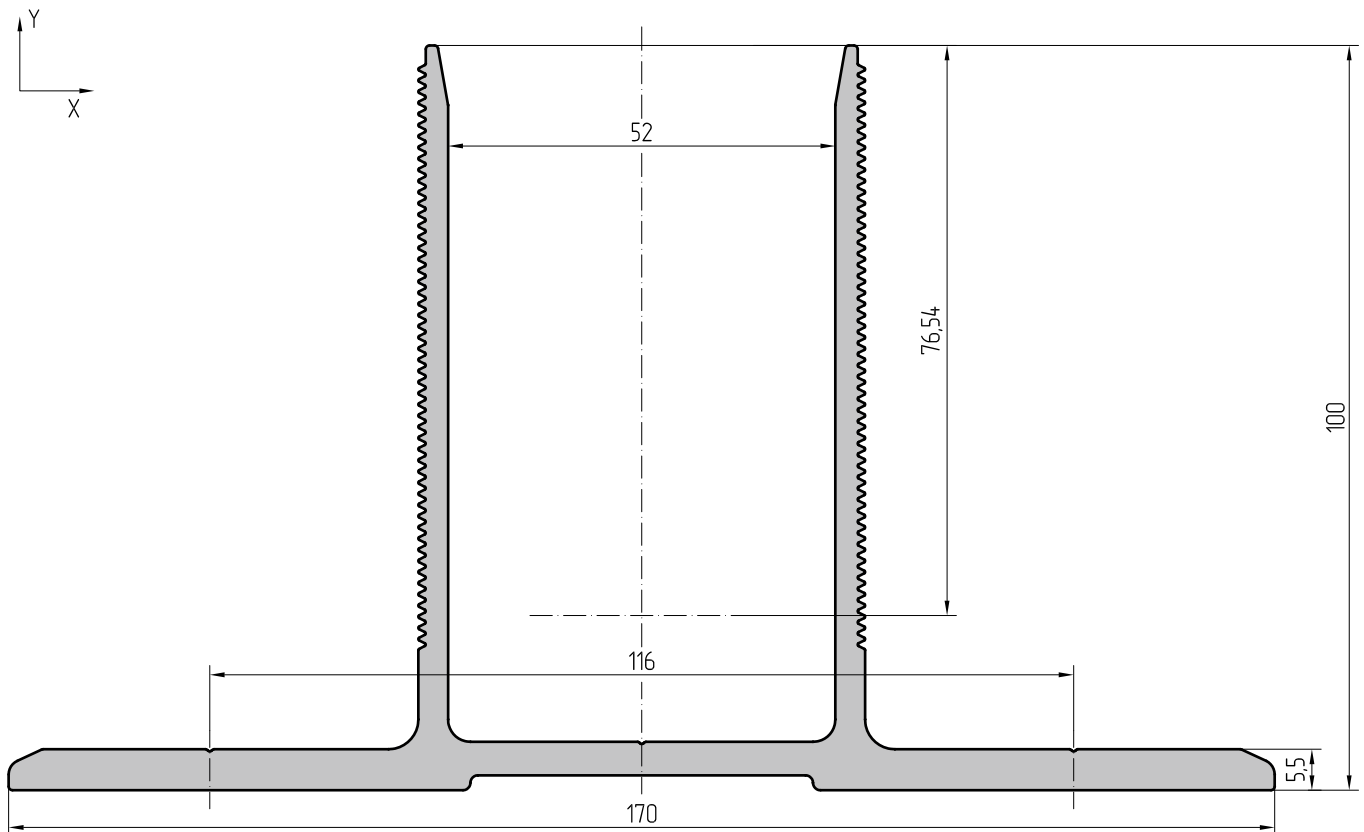

Scale 1:1		Bracket profile 170x100 mm	
AYPC.150.0307	Article	Central moments of inertia	
4,200 kg	Theoretical weight 1 m	Jx=135,65 cm <sup>4</sup>	Jy=269,64 cm <sup>4</sup>
833,2 mm	External perimeter	Moments of resistance	
15,556 cm <sup>2</sup>	Cross section area	Wx=17,97 cm <sup>3</sup>	Wy=31,72 cm <sup>3</sup>

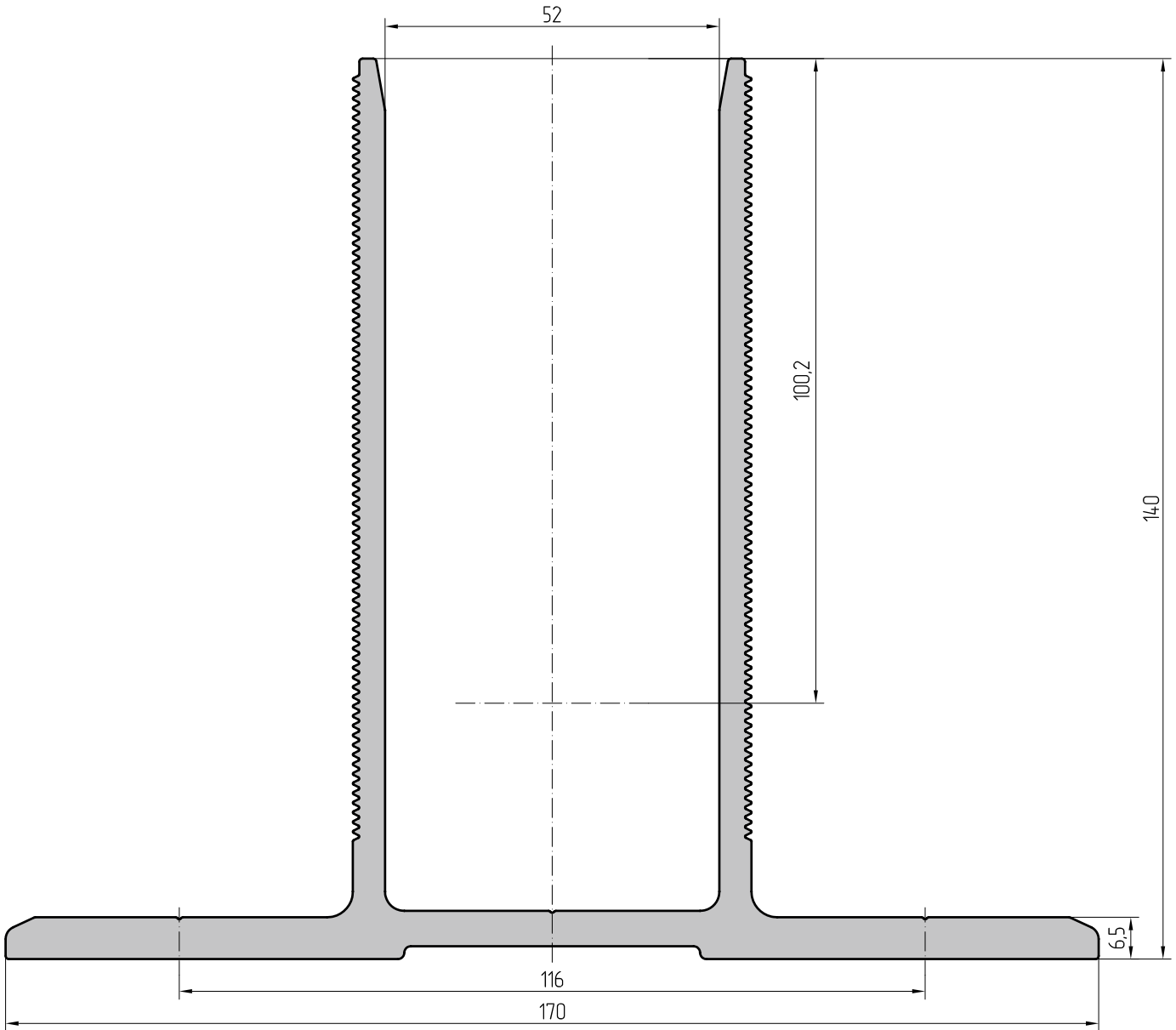
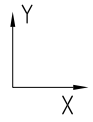

Scale 1:1		Bracket profile 170x140 mm	
AYPC.150.0308	Article	Central moments of inertia	
6,112 kg	Theoretical weight 1 m	$J_x=439,93 \text{ cm}^4$	$J_y=355,65 \text{ cm}^4$
1052,4 mm	External perimeter	Moments of resistance	
22,639 cm <sup>2</sup>	Cross section area	$W_x=43,91 \text{ cm}^3$	$W_y=41,84 \text{ cm}^3$

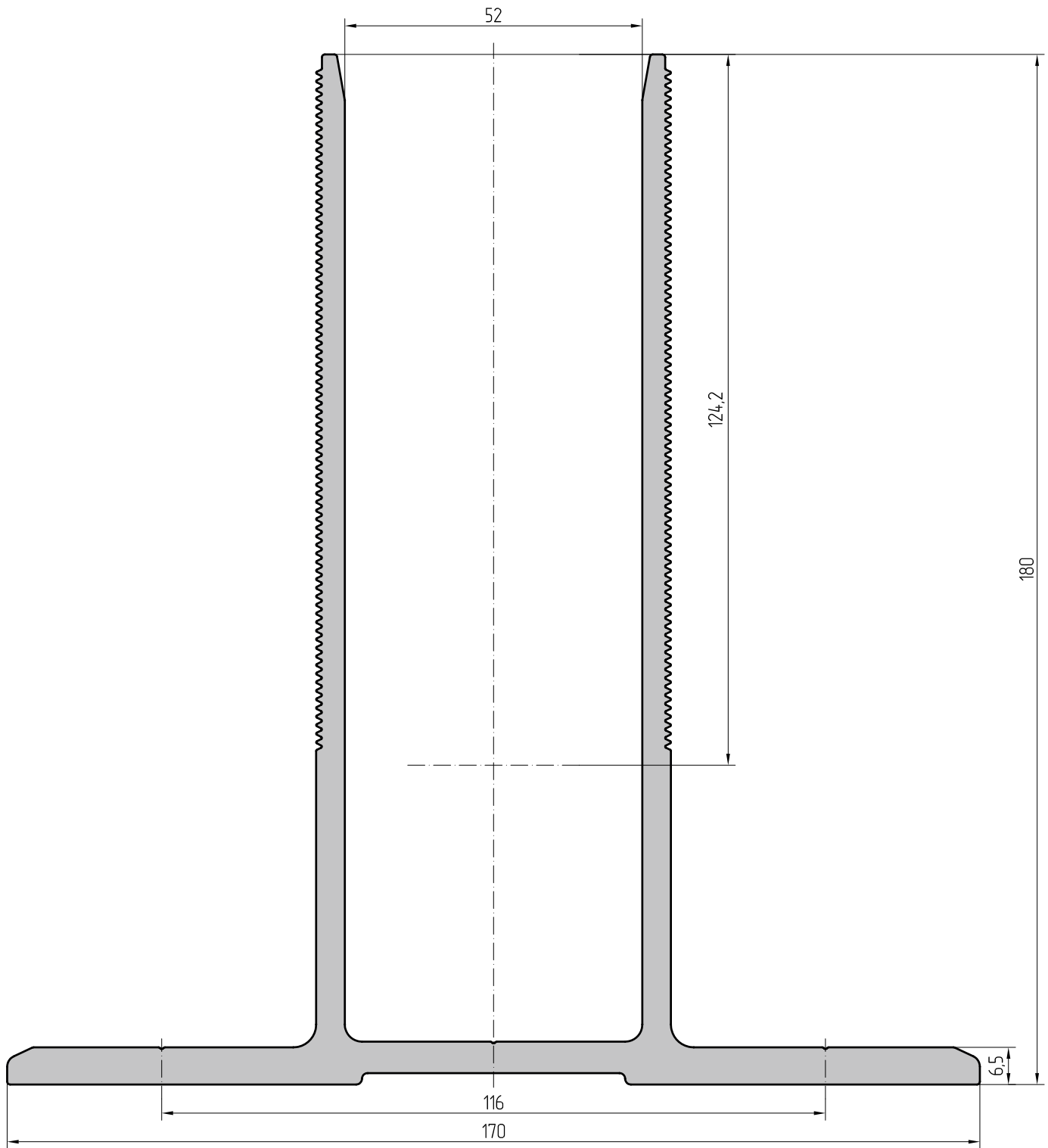
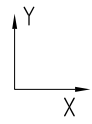

Scale 1:1	Bracket profile 170x180 mm		
AYPC.150.0309	Article	Central moments of inertia	
7,193 kg	Theoretical weight 1 m	Jx=883,86 cm <sup>4</sup>	Jy=388,22 cm <sup>4</sup>
1212,4 mm	External perimeter	Moments of resistance	
26,639 cm <sup>2</sup>	Cross section area	Wx=71,16 cm <sup>3</sup>	Wy=45,67 cm <sup>3</sup>







# REINFORCED PROFILES (1:1)

The chapter is under revision from April 12, 2017.  
Final version will be available on May 01, 2017





**ALUFACH ALT F50**  
CURTAIN WALL  
SYSTEM

# VENTILATION AND MOISTURE REMOVAL

08



Layout of ventilation and moisture removal from the seam of a glass unit for straight transparent part of curtain wall

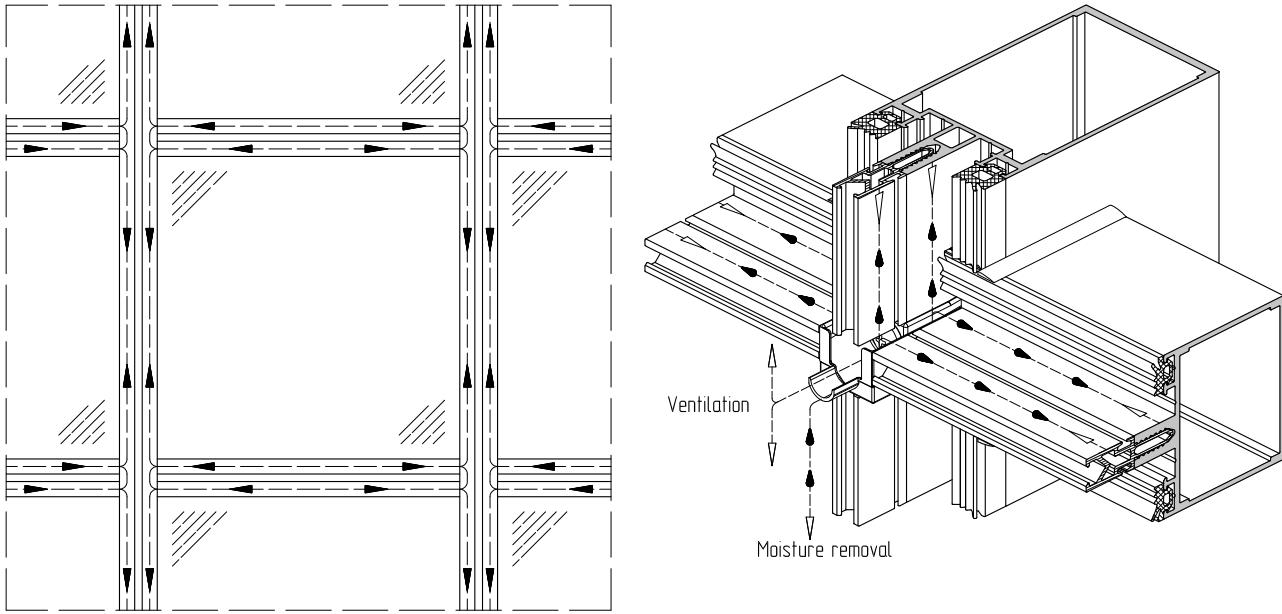

Moisture removal and air circulation is made through special holes in vertical clamp bars.

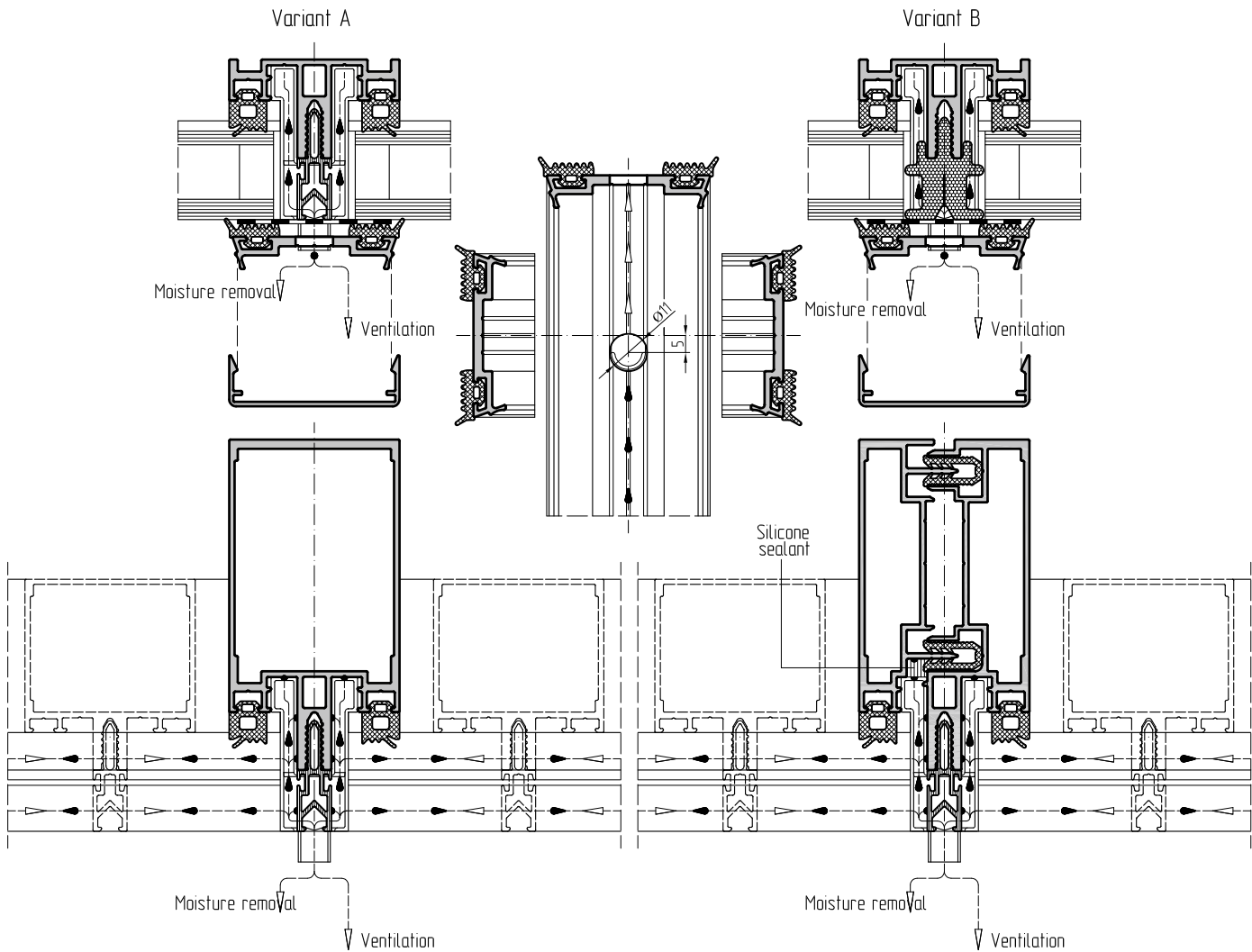

Layout of ventilation and moisture removal from the seam of a glass unit for straight non-transparent part of curtain wall with vapour seal

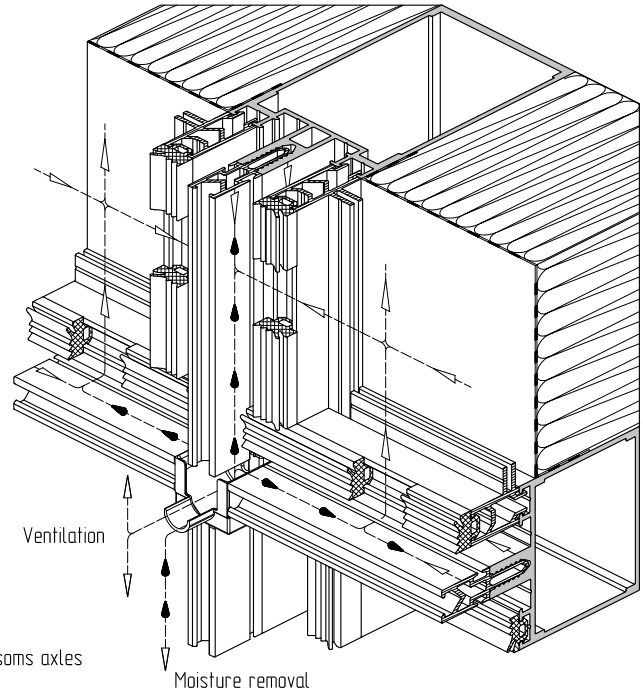
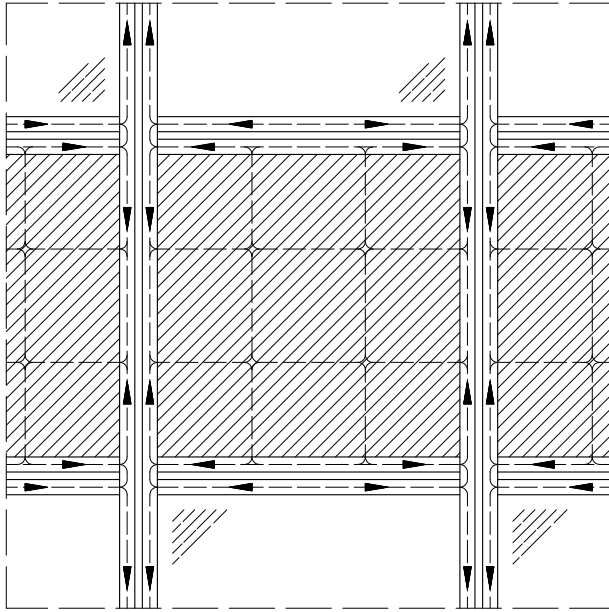

For moisture removal and ventilation make 50 mm long cuts, at a distance of 225 mm from the mullions and transoms axles. The distance between cuts should be 500 mm

Variant A

Variant B

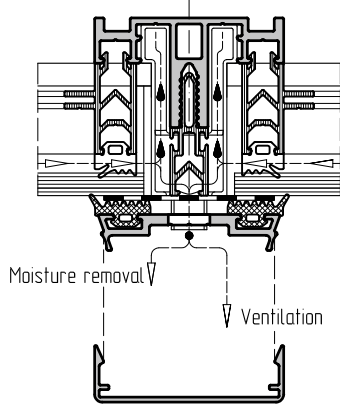

Moisture removal and air circulation is made through special holes in vertical clamp bars.

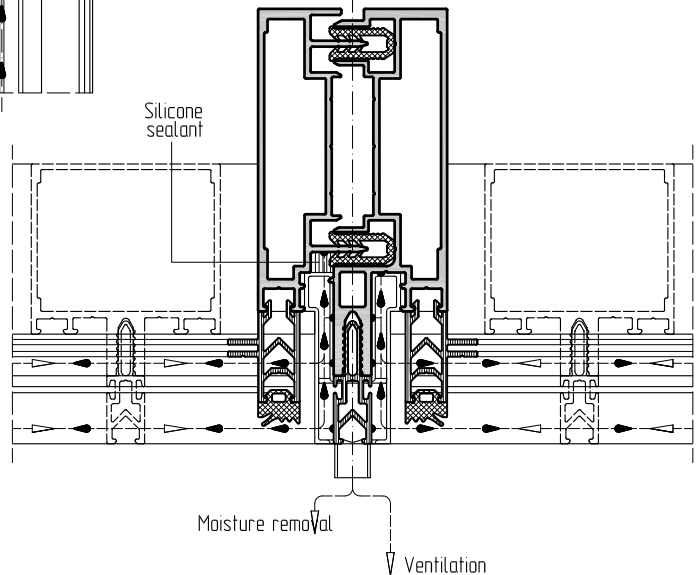
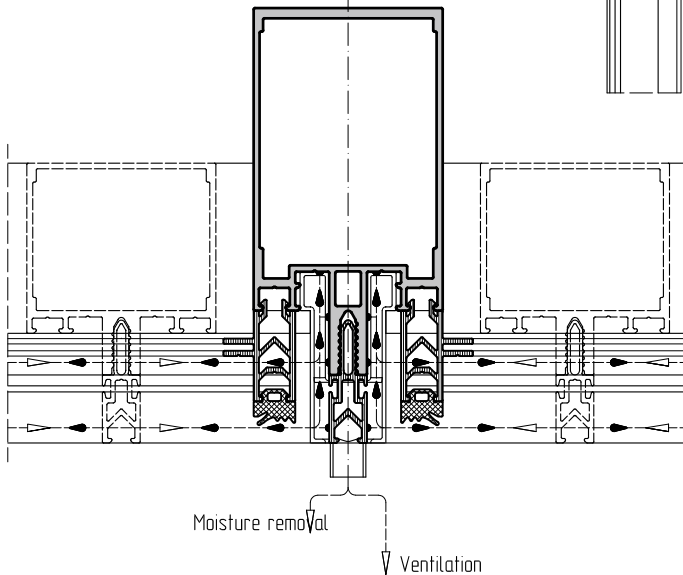
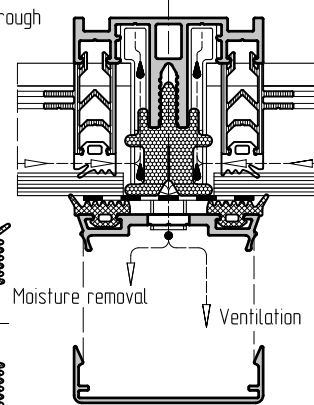
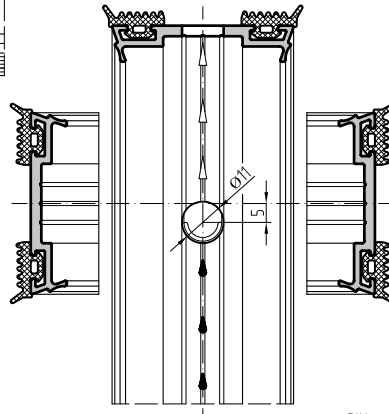

Layout of ventilation and moisture removal from the seam of a glass unit for straight non-transparent part of facade with vapour seal and 1,5 mm aluminium sheet

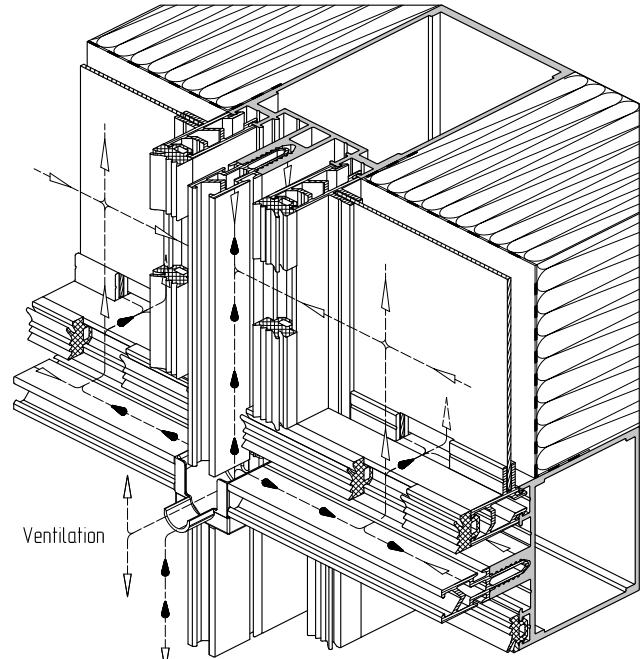
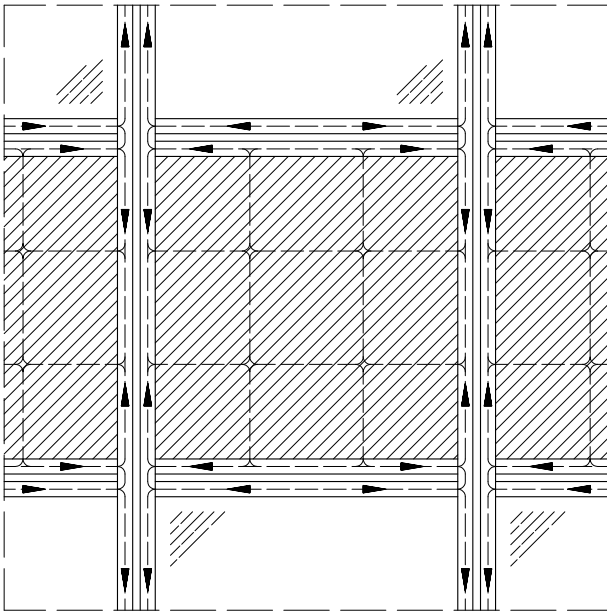

⚠ For moisture removal and ventilation 50 mm long cuts should be made at 225 mm distance from mullions and transoms axles. The distance between cuts should be 500 mm.

Variant A

Variant B

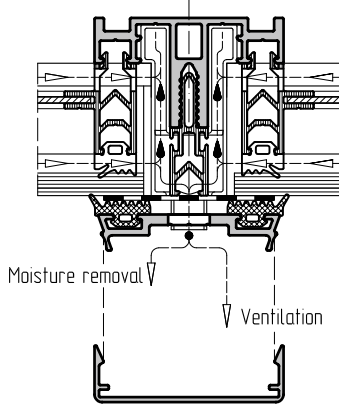

Moisture removal and air circulation is made through holes in vertical clamp bars.

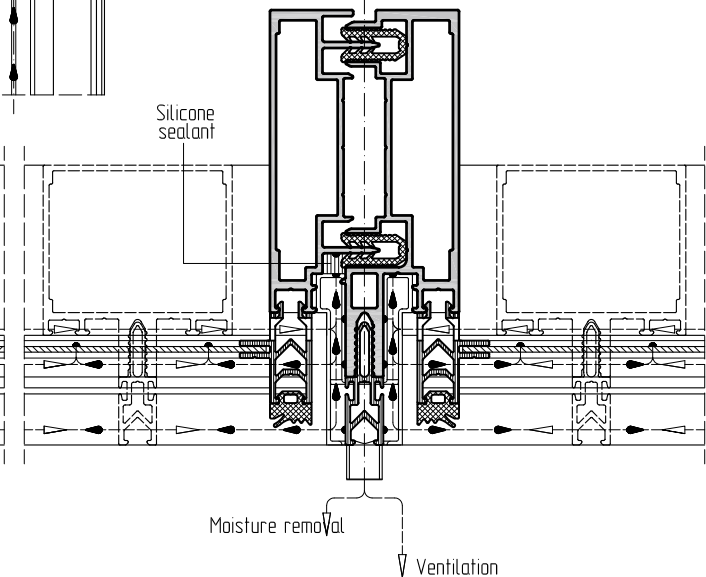
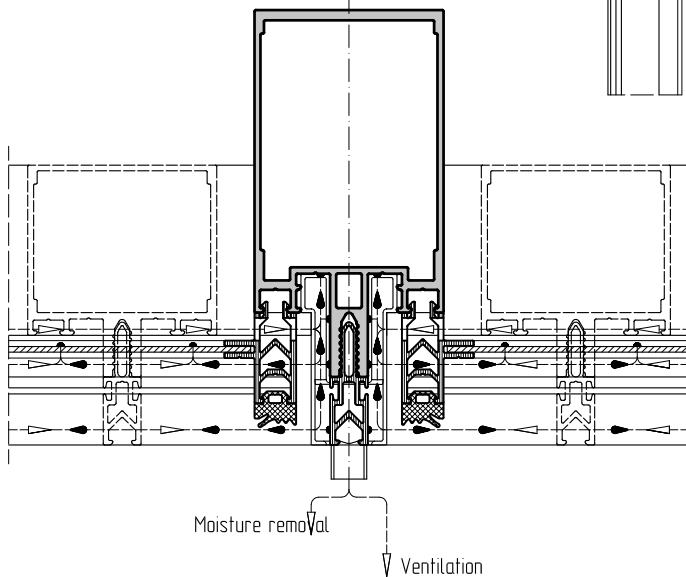
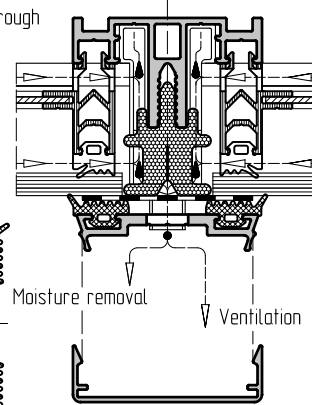
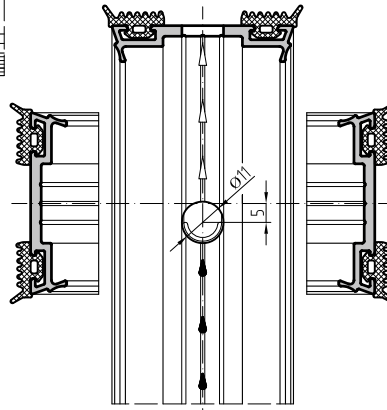

Layout of ventilation and moisture removal from the seam of a glass unit for straight non-transparent part of facade

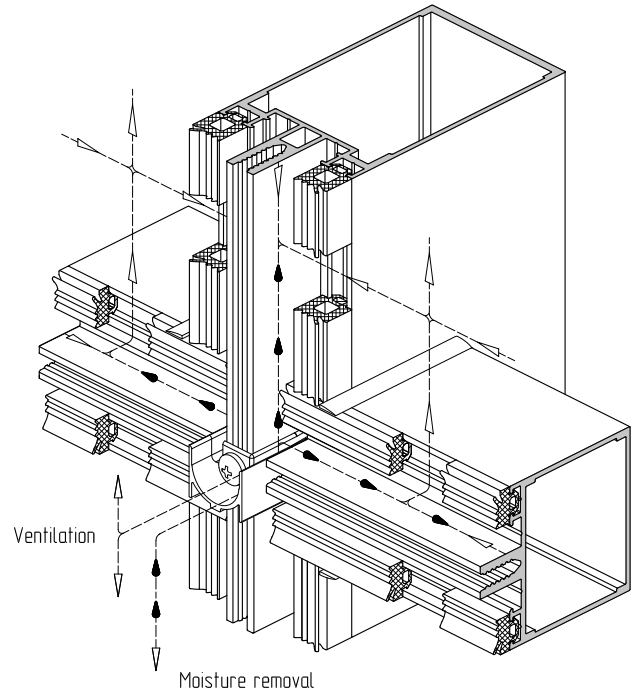
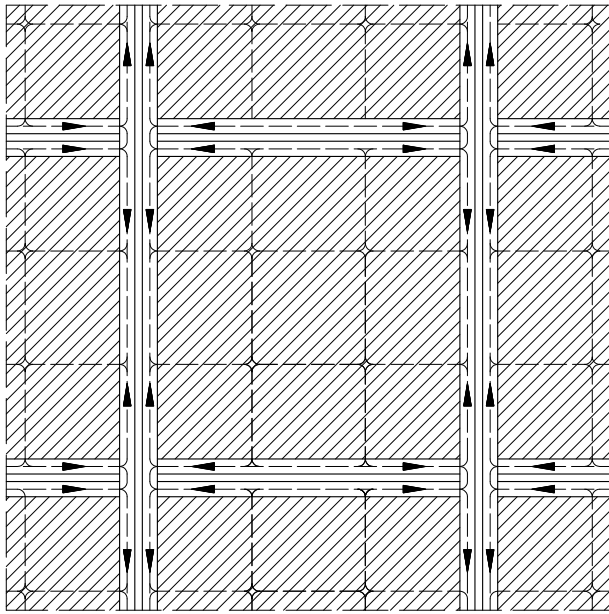

For moisture removal and ventilation 50 mm long cuts should be made at 225 mm distance from mullions and transoms axes. The distance between cuts should be 500 mm.

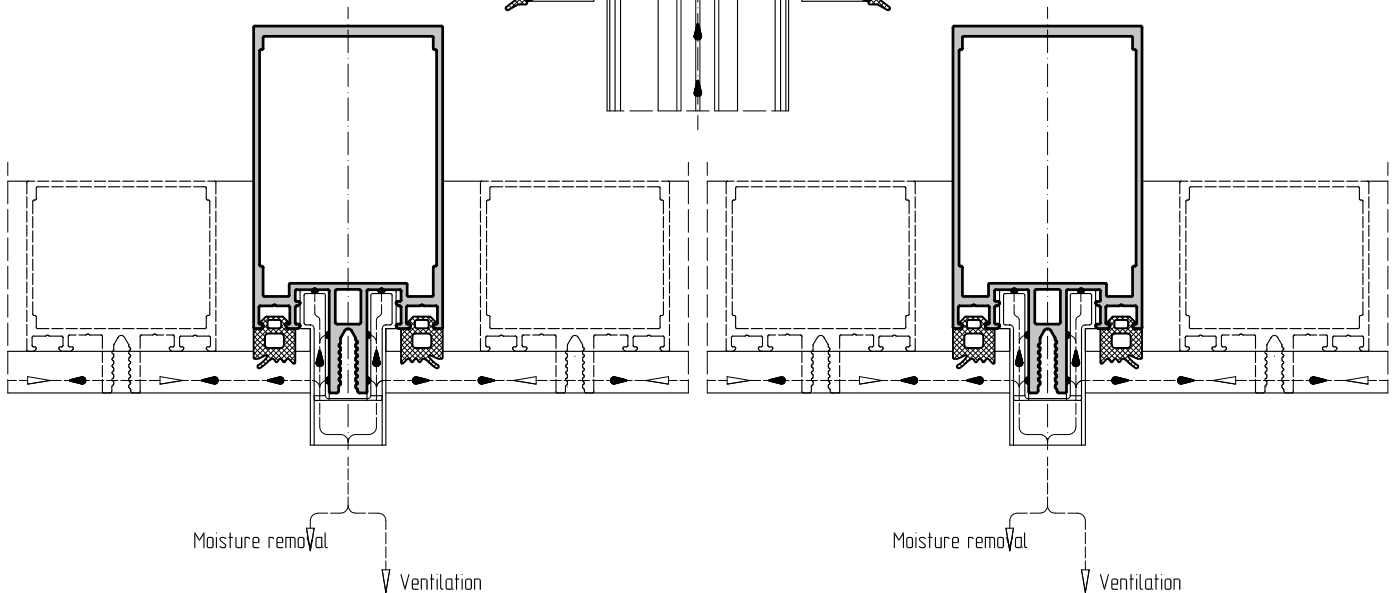
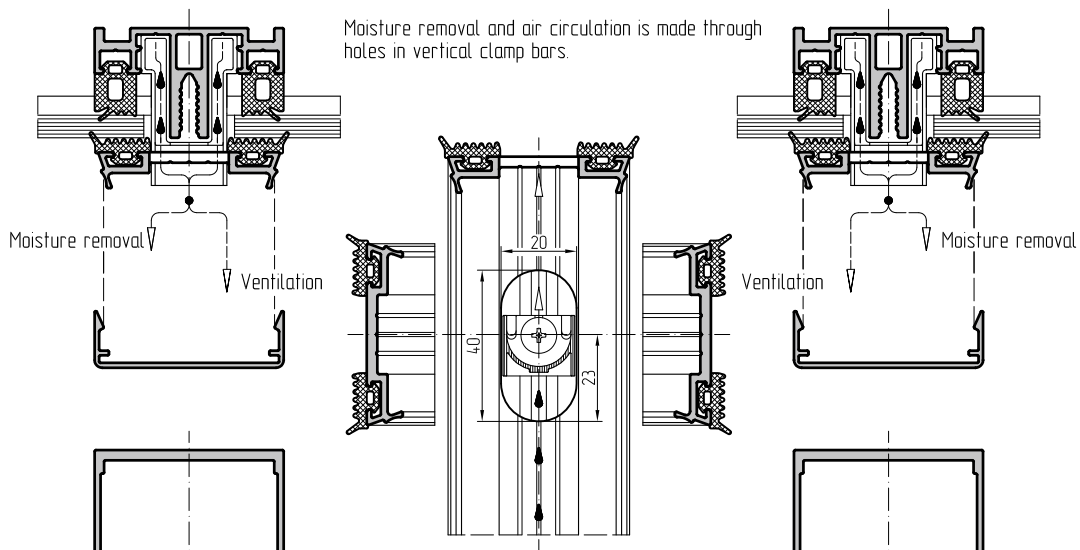



Layout of ventilation and moisture removal from the seam of a glass unit for straight transparent part of curtain wall

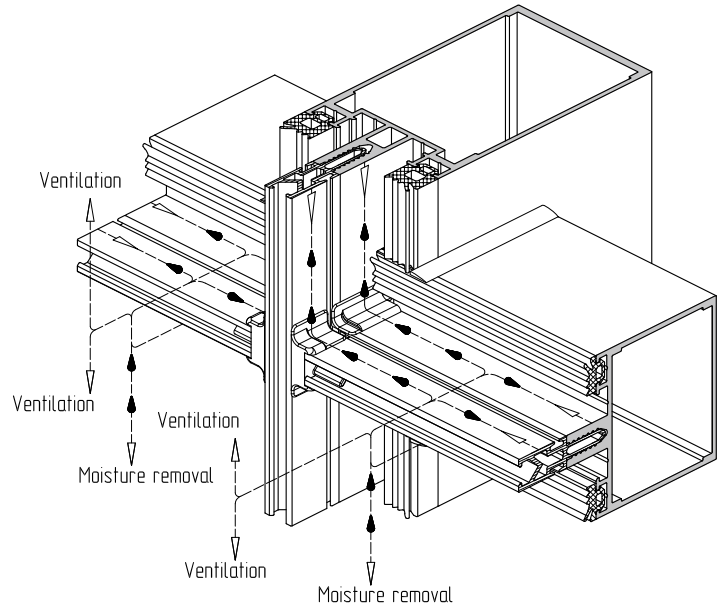
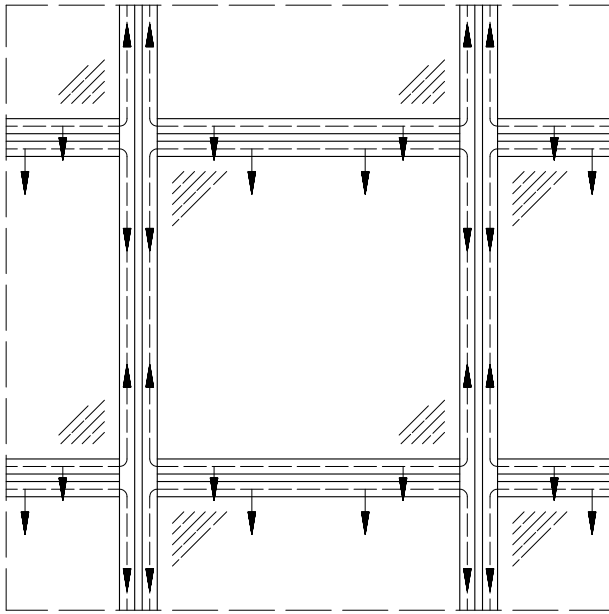

Moisture removal and air circulation is made through special holes in clamp bars and cover caps.

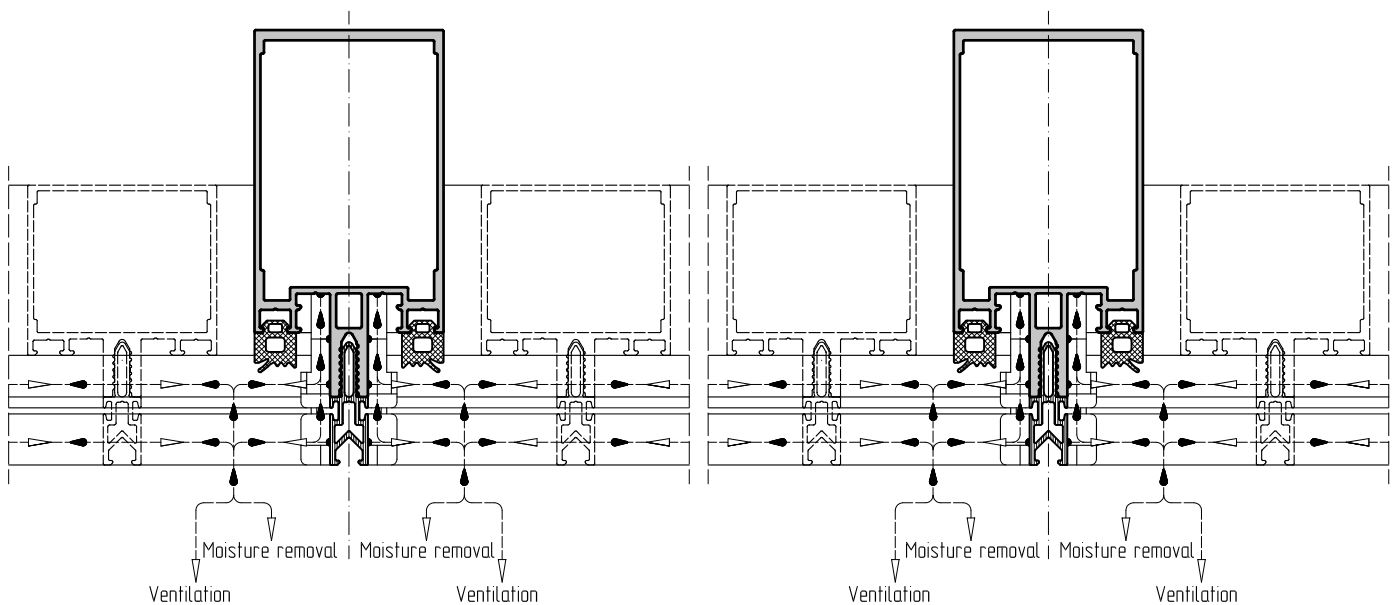
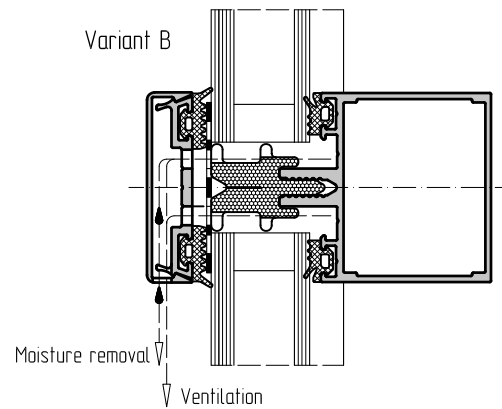
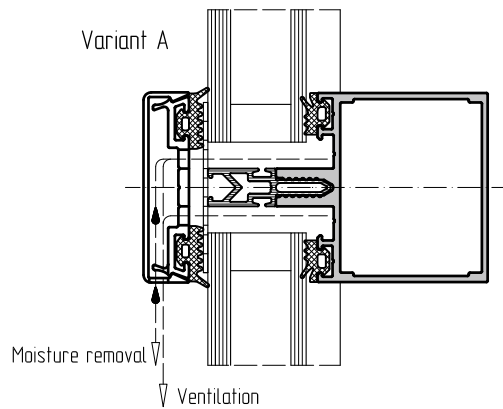

Layout of ventilation and moisture removal from the seam of a glass unit for straight non-transparent part of curtain wall with vapour seal

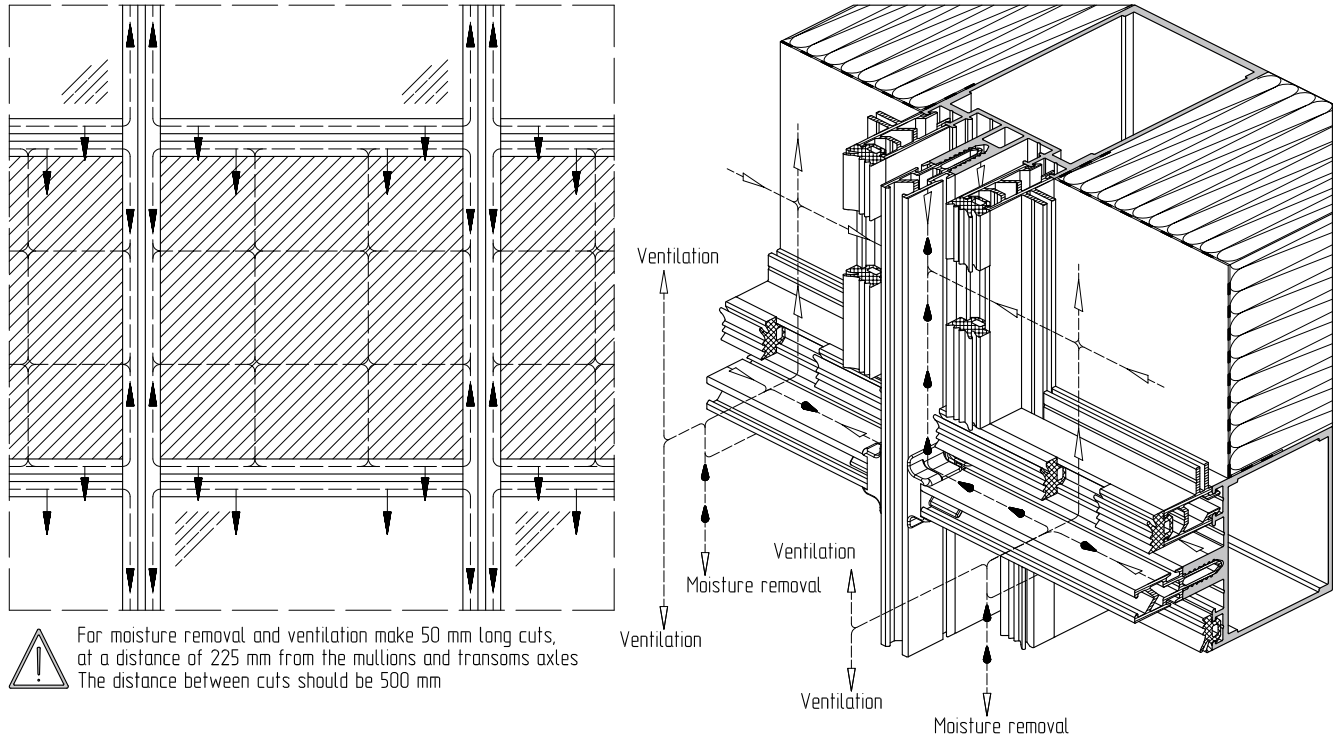

Moisture removal and air circulation is made through special holes in clamp bars and cover caps.

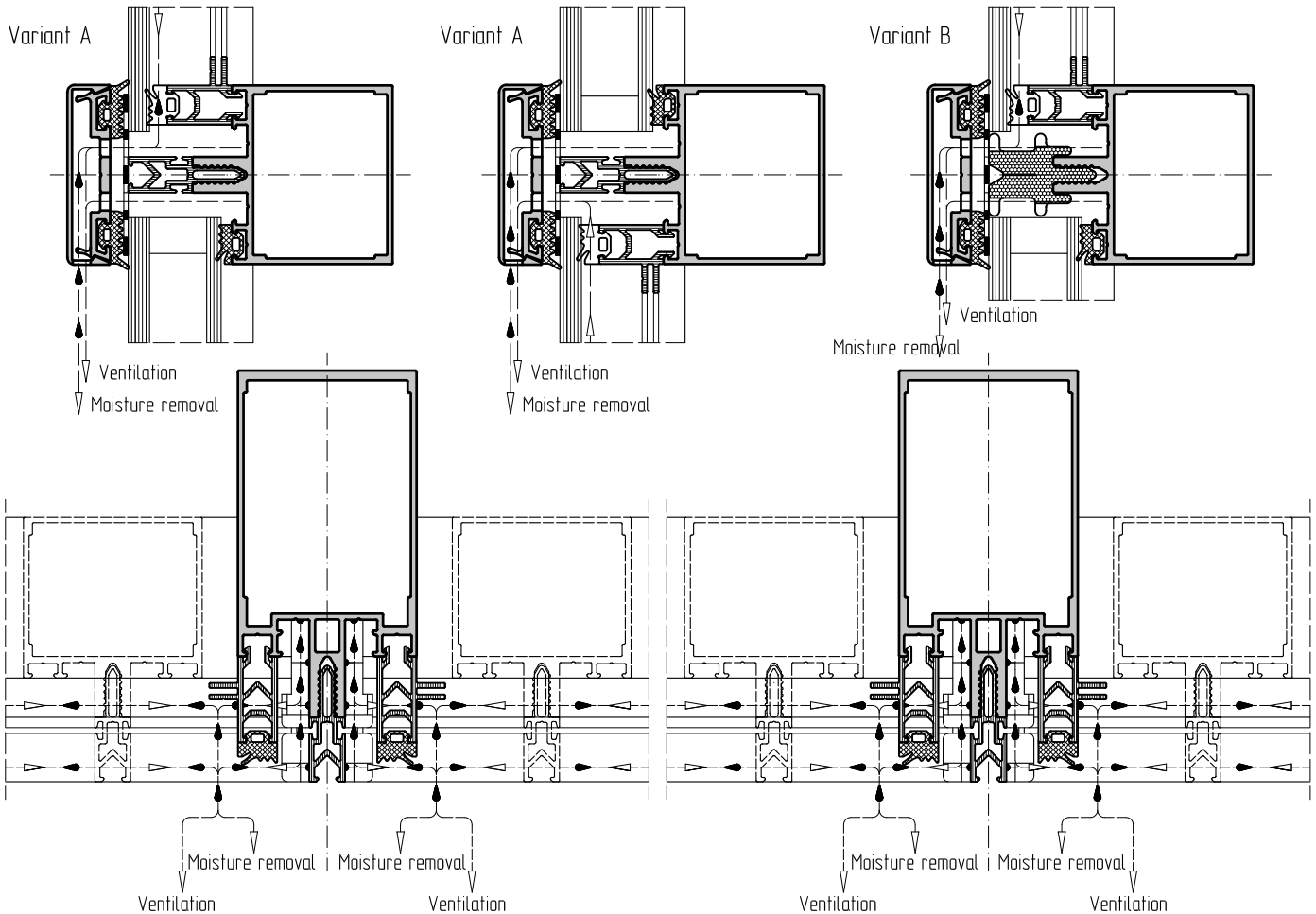

Layout of ventilation and moisture removal from the seam of a glass unit for straight non-transparent part of curtain wall with vapour seal and 1,5 mm aluminium sheet

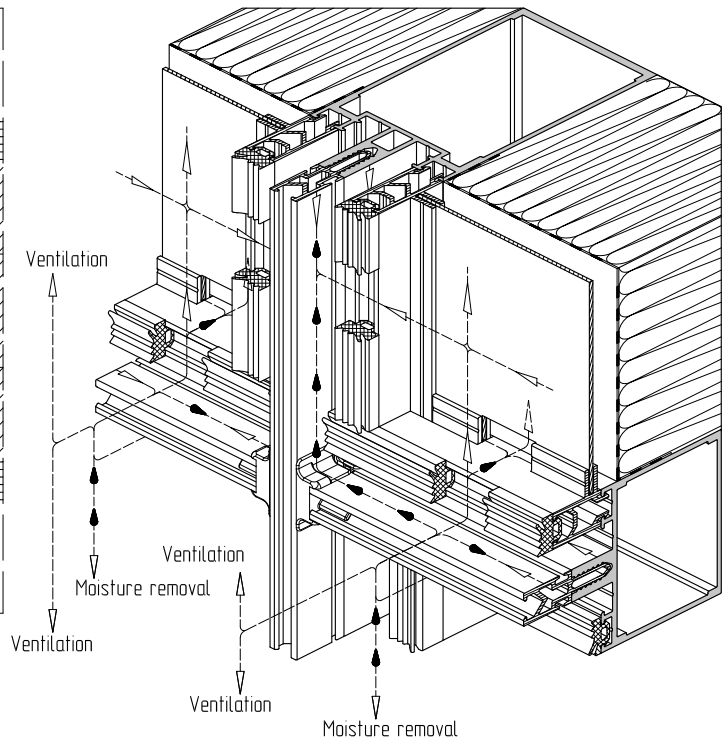
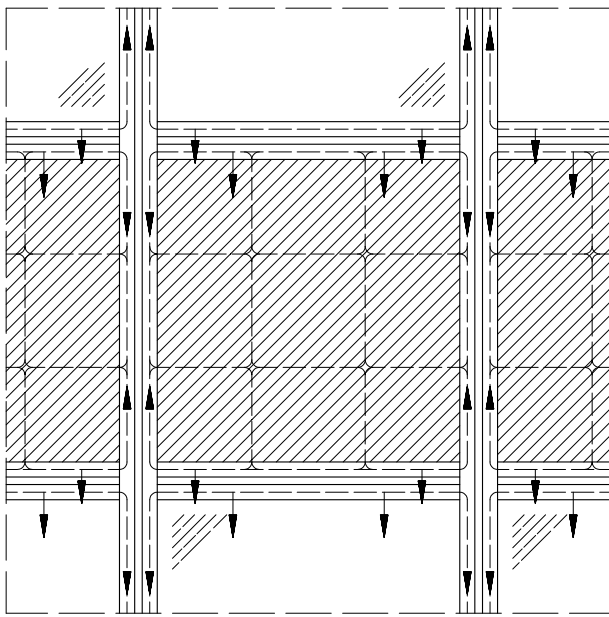

⚠ For moisture removal and ventilation make 50 mm long cuts, at a distance of 225 mm from the mullions and transoms axes. The distance between cuts should be 500 mm

Moisture removal and air circulation is made through special holes in clamp bars and cover caps.

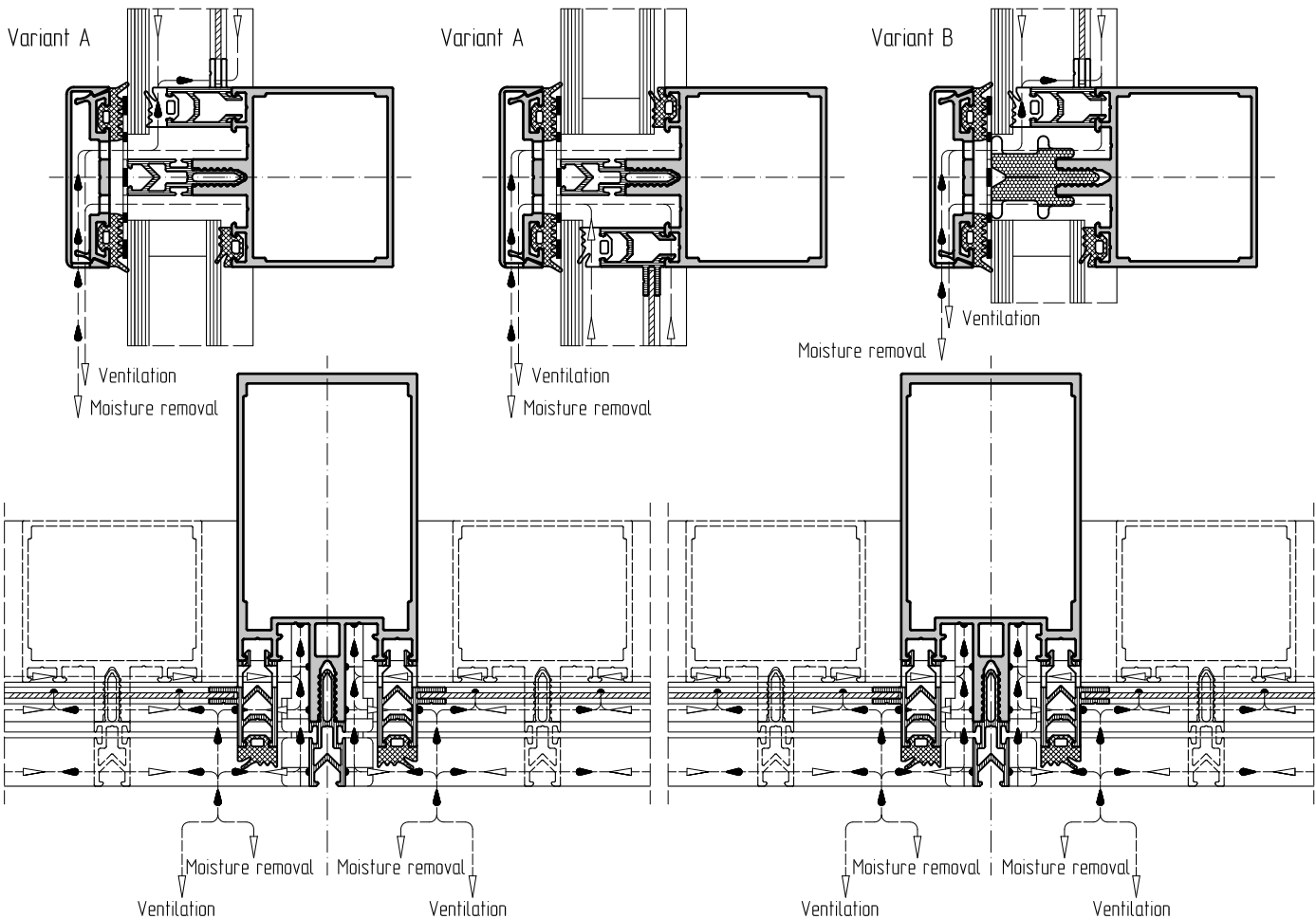

Layout of ventilation and moisture removal from the seam of a glass unit for straight transparent part of facade

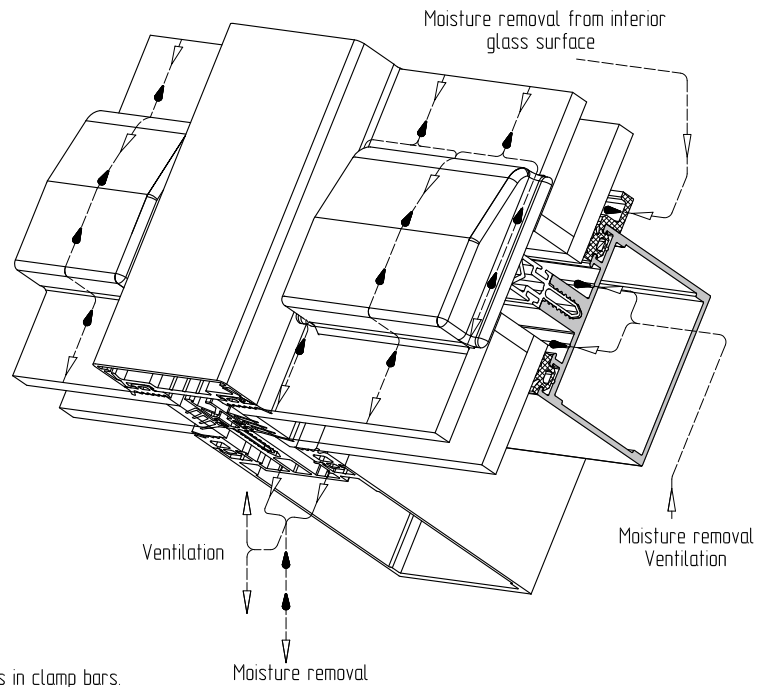
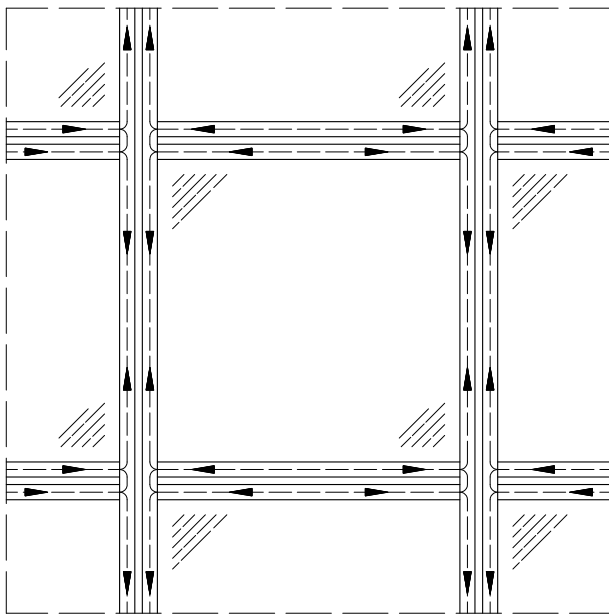

Moisture and condensate removal is made through transom trays and holes in clamp bars.

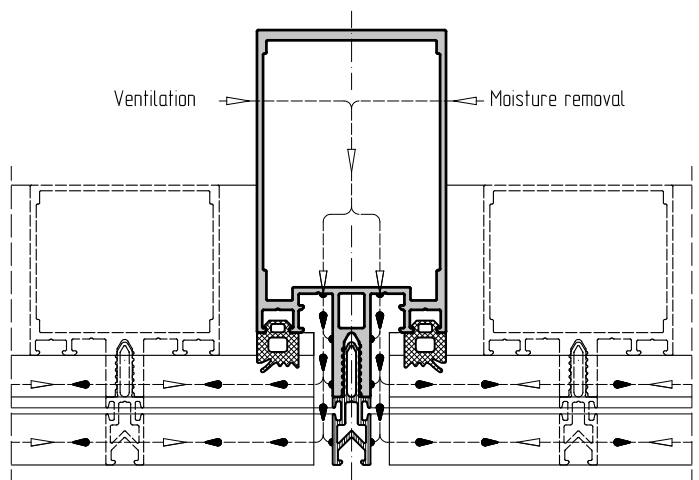
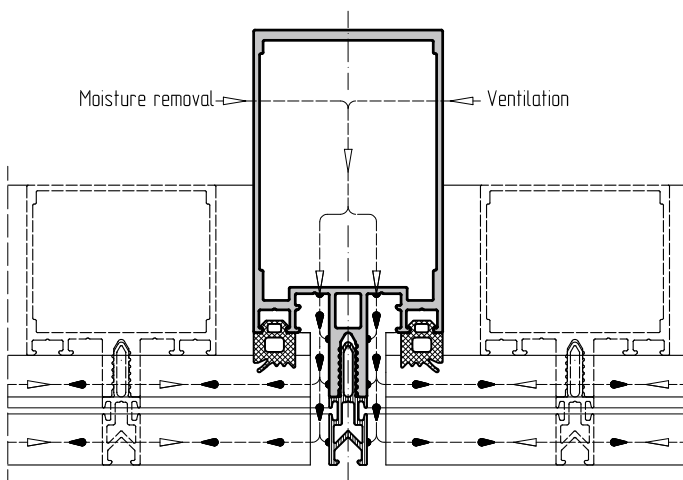
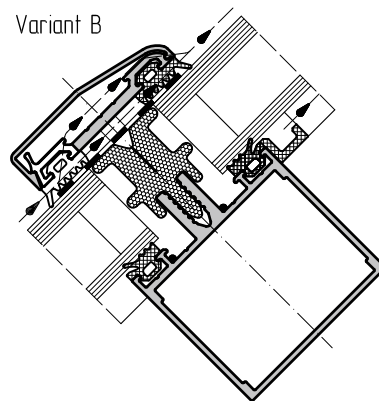
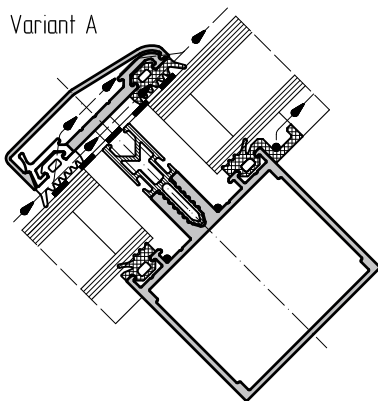

Layout of ventilation and moisture removal from the seam of a glass unit for straight part of facade

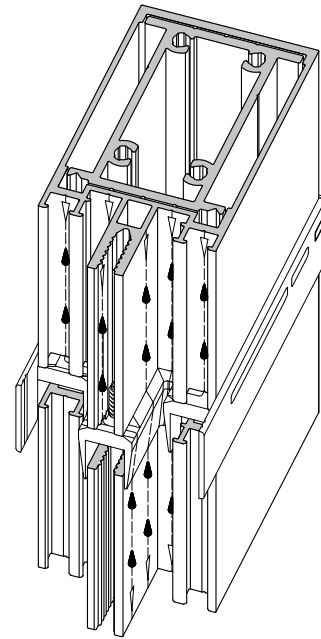
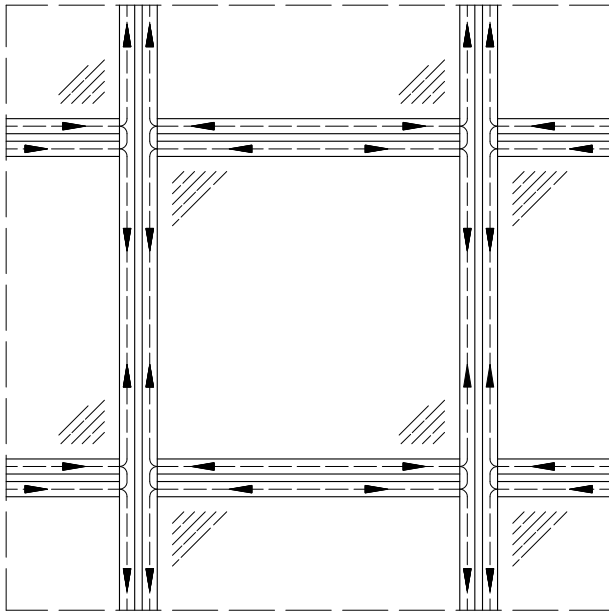

Moisture transfer and air circulation is made at the joint of mullions

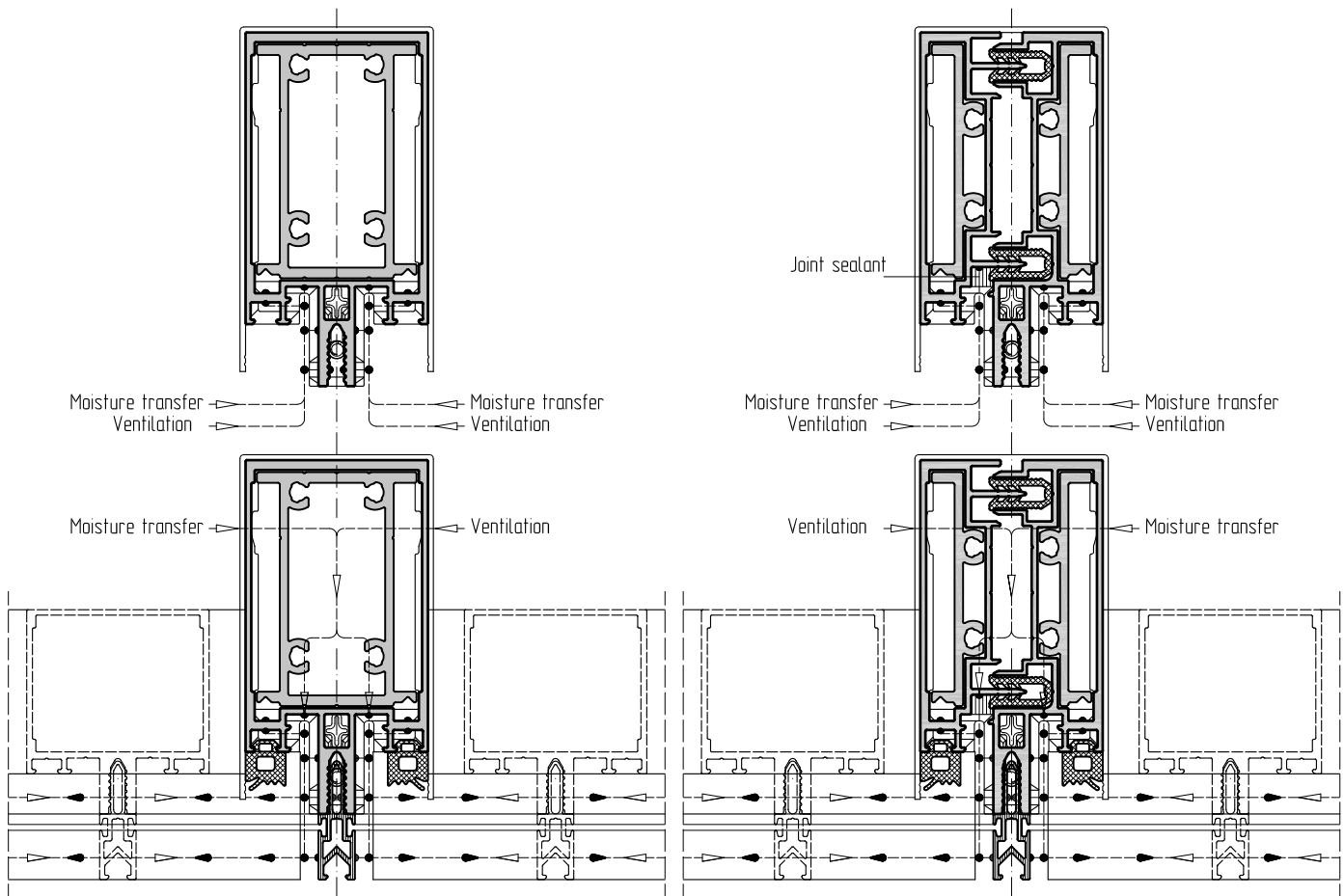

Layout of ventilation and moisture removal from the seam of a glass unit for straight transparent part of facade

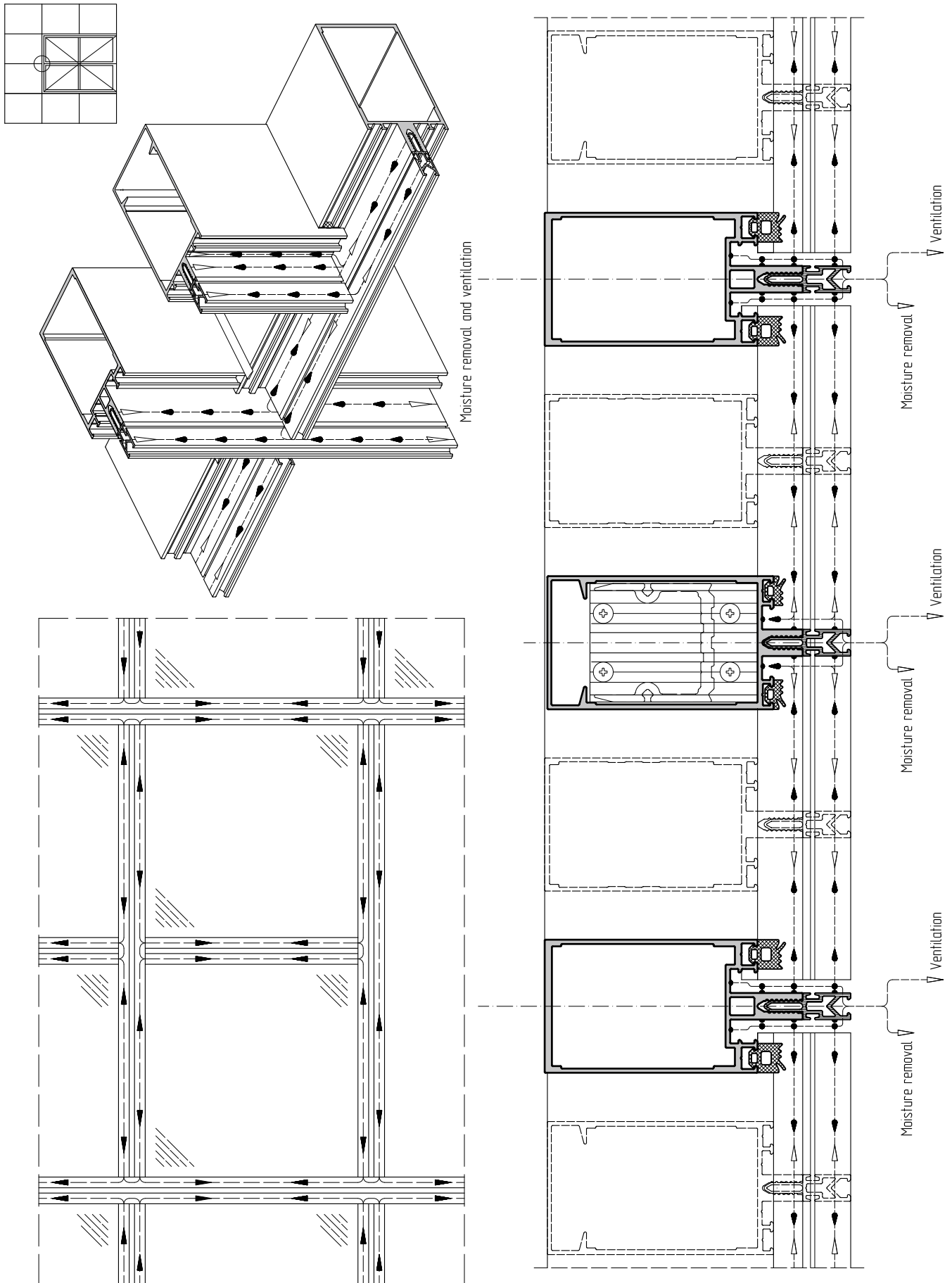

Layout of ventilation and moisture removal from the seam of a glass unit for straight transparent part of facade

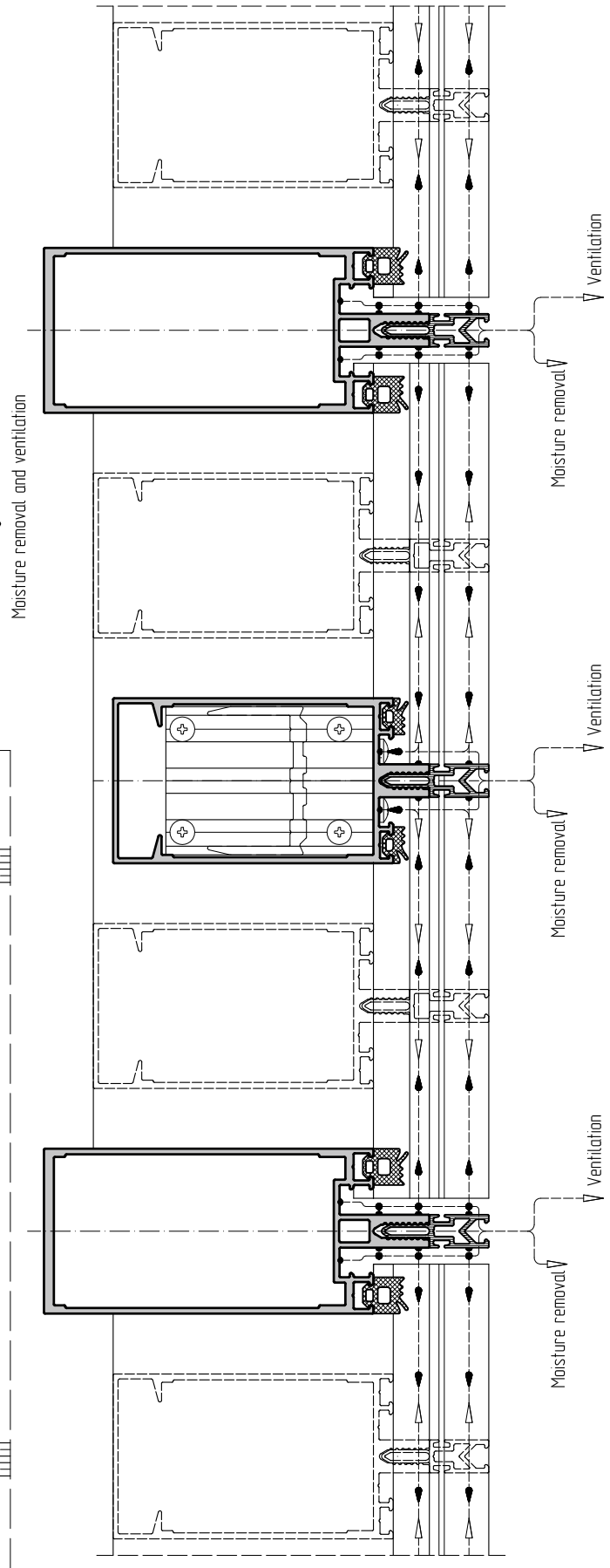
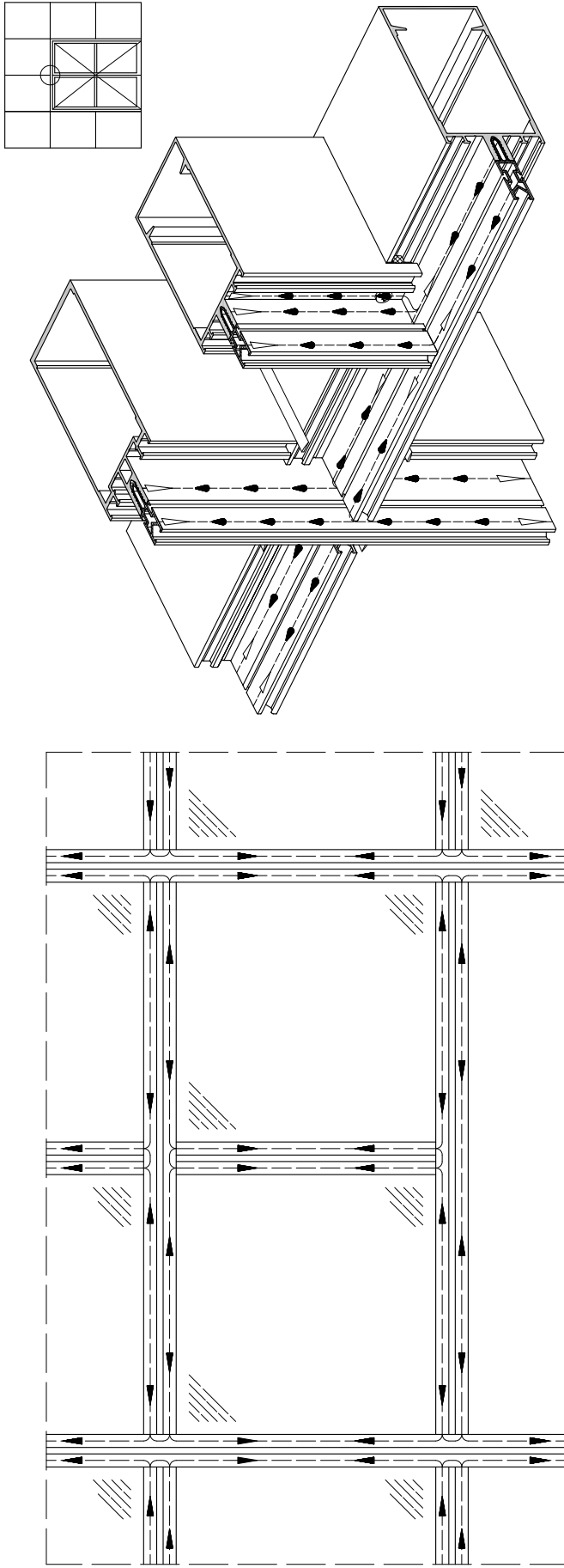

Layout of ventilation and moisture removal from the seam of a glass unit for straight transparent part of facade

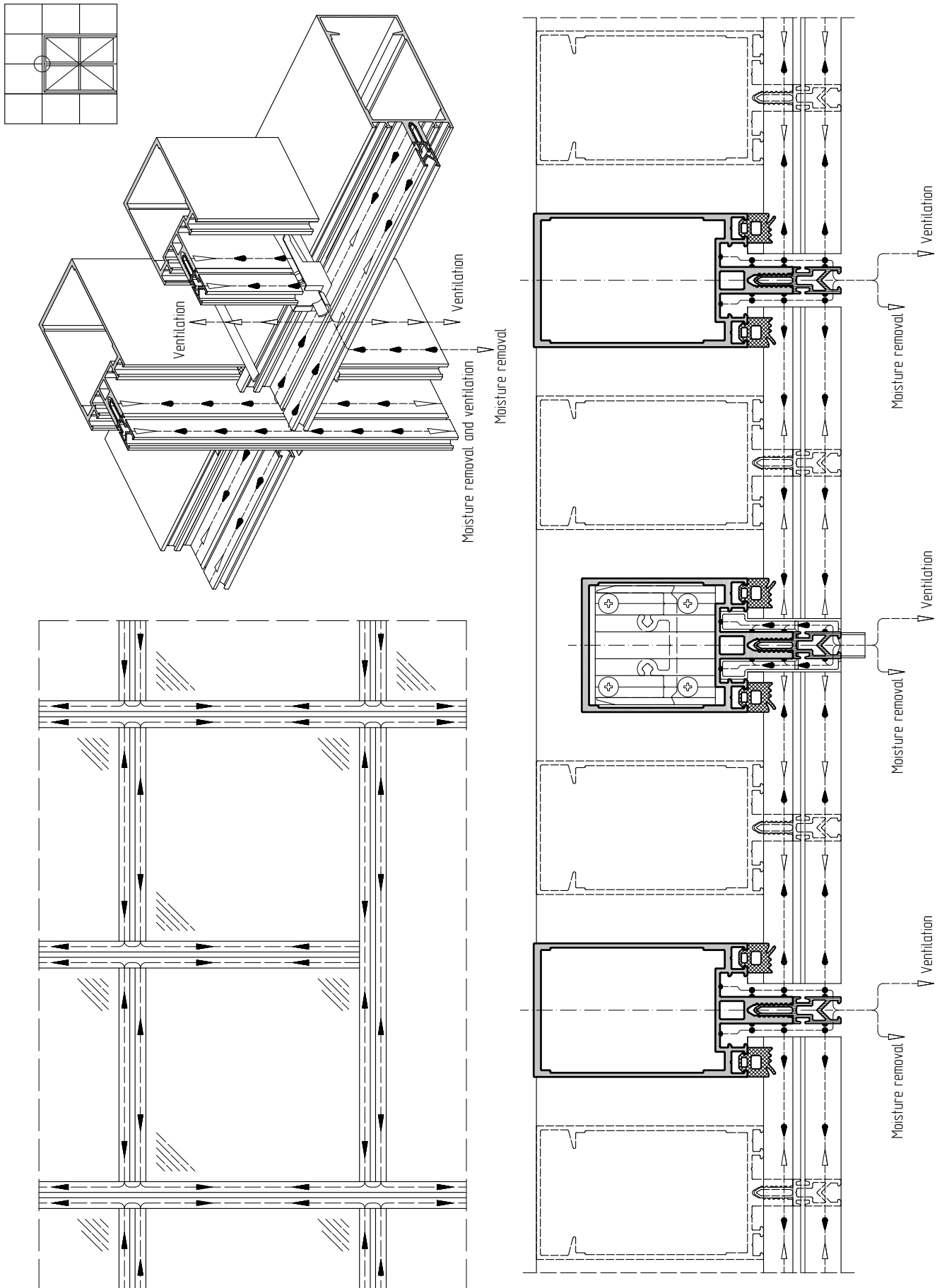



Moisture removal and vapour levelling at the seam zone of a glass unit for straight part of facade

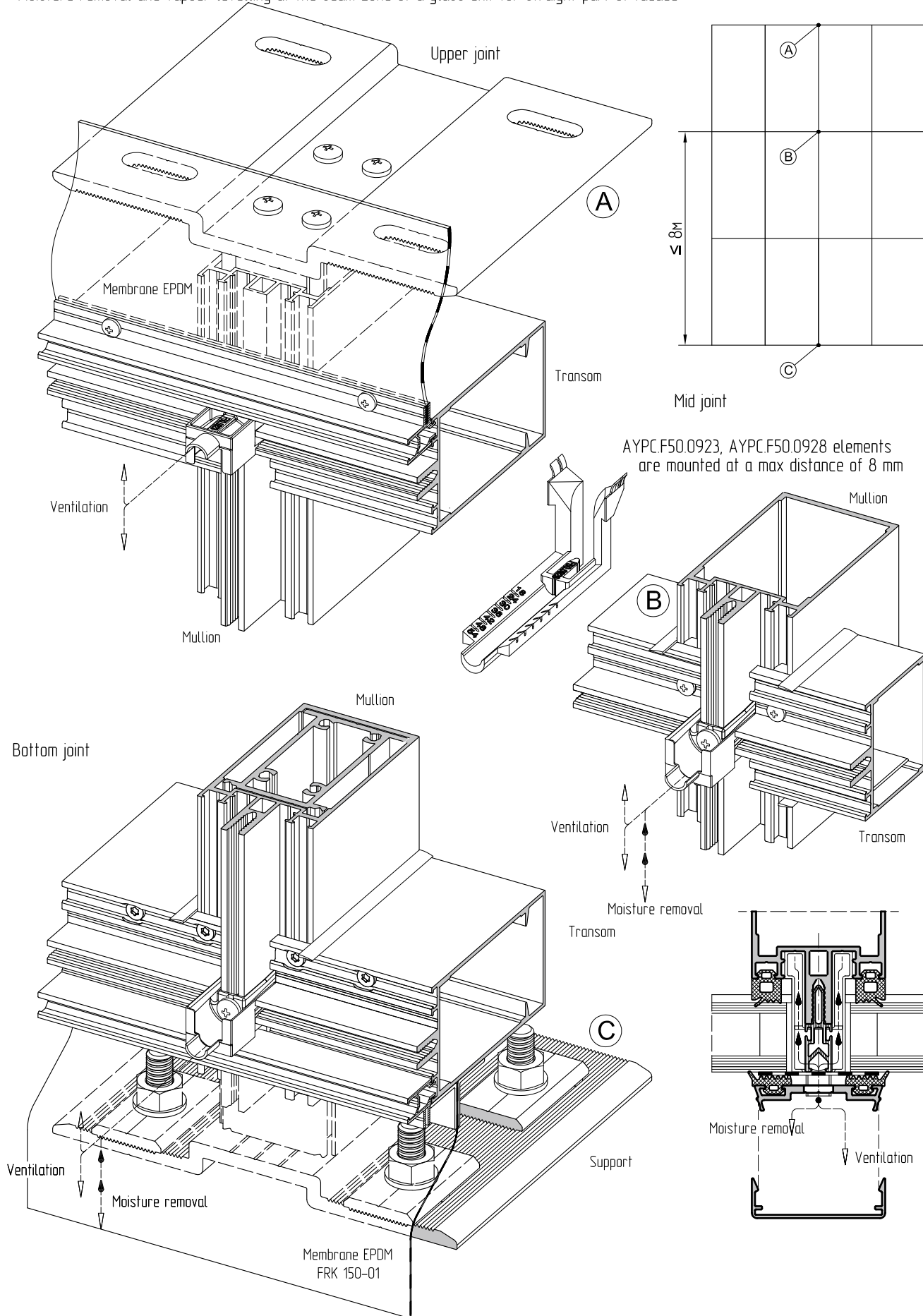





**ALUFACH ALT F50**  
CURTAIN WALL  
SYSTEM

# GLAZING TABLE

09



Curtain wall glazing depending on the type of profiles integrated

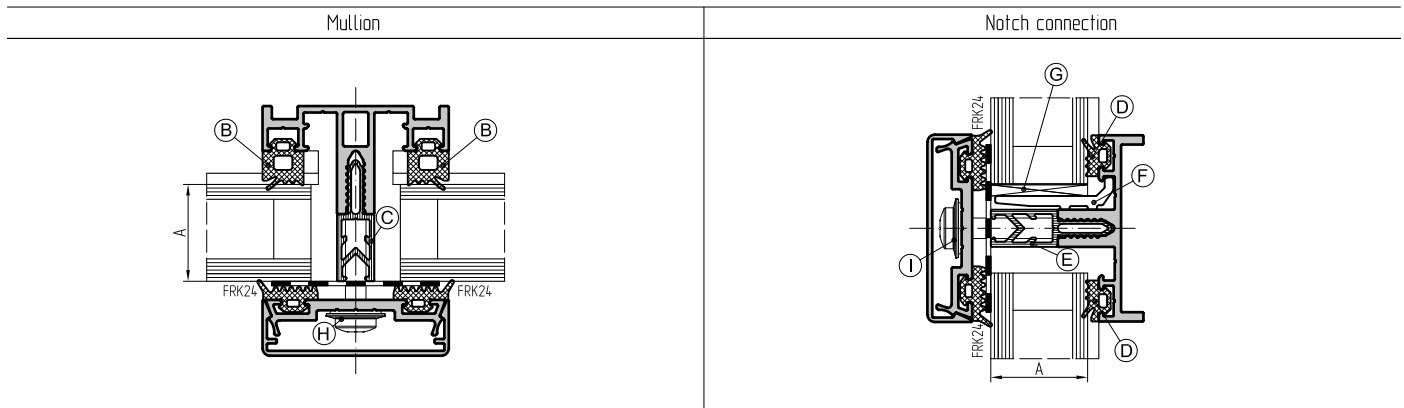

Glazing thickness	Mullion gasket	Mullion thermal break	Notch connection transom gasket	Notch connection transom thermal break	Glass support			Self-tapping screw $\varnothing$ 5,5 DIN 7981		
					bearing	leveling				
A	B	C	D	E	F	G		H/I		
4 mm	FRK19	-	FRK16	-	AYPC.F50.0940	FRK13	1 mm		5,5x22/5,5x22	
5 mm/6 mm	FRK18	-	FRK15	-	AYPC.F50.0940	FRK13	1 mm		5,5x22/5,5x22	
8 mm	FRK17	-	FRK14	-	AYPC.F50.0940	FRK13	1 mm		5,5x22/5,5x22	
22 mm	FRK19	AYPC.F50.0905 AYPC.F50.0908	FRK16	AYPC.F50.0905 AYPC.F50.0908	AYPC.F50.0941	100x26	x1	x2	x3	5,5x38/5,5x38
24 mm	FRK18	AYPC.F50.0905 AYPC.F50.0908	FRK15	AYPC.F50.0905 AYPC.F50.0908	AYPC.F50.0941	100x26	x1	x2	x3	5,5x38/5,5x38
26 mm	FRK17	AYPC.F50.0905 AYPC.F50.0908	FRK14	AYPC.F50.0905 AYPC.F50.0908	AYPC.F50.0941	100x26	x1	x2	x3	5,5x38/5,5x38
28 mm	FRK19	AYPC.F50.0906 AYPC.F50.0909	FRK16	AYPC.F50.0906 AYPC.F50.0909	AYPC.F50.0941-01	100x32	x1	x2	x3	5,5x45/5,5x45
30 mm	FRK18	AYPC.F50.0906 AYPC.F50.0909	FRK15	AYPC.F50.0906 AYPC.F50.0909	AYPC.F50.0941-01	100x32	x1	x2	x3	5,5x45/5,5x45
32 mm	FRK17	AYPC.F50.0906 AYPC.F50.0909	FRK14	AYPC.F50.0906 AYPC.F50.0909	AYPC.F50.0941-01	100x32	x1	x2	x3	5,5x45/5,5x45
34 mm	FRK19	AYPC.F50.0907 AYPC.F50.0910	FRK16	AYPC.F50.0907 AYPC.F50.0910	AYPC.F50.0941-02	100x38	x1	x2	x3	5,5x55/5,5x55
36 mm	FRK18	AYPC.F50.0907 AYPC.F50.0910	FRK15	AYPC.F50.0907 AYPC.F50.0910	AYPC.F50.0941-02	100x38	x1	x2	x3	5,5x55/5,5x55
38 mm	FRK17	AYPC.F50.0907 AYPC.F50.0910	FRK14	AYPC.F50.0907 AYPC.F50.0910	AYPC.F50.0941-02	100x38	x1	x2	x3	5,5x55/5,5x55
40 mm	FRK19	AYPC.F50.0915 AYPC.F50.0911	FRK16	AYPC.F50.0915 AYPC.F50.0911	AYPC.F50.0948-01 AYPC.F50.0949-01 2x8c.5,5x35 ISO 7462	100x44	x1	x2	x3	5,5x60/5,5x60
42 mm	FRK18	AYPC.F50.0915 AYPC.F50.0911	FRK15	AYPC.F50.0915 AYPC.F50.0911		100x44	x1	x2	x3	5,5x60/5,5x60
44 mm	FRK17	AYPC.F50.0915 AYPC.F50.0911	FRK14	AYPC.F50.0915 AYPC.F50.0911	100x44	x1	x2	x3	5,5x60/5,5x60	
46 mm	FRK19	AYPC.F50.0916 AYPC.F50.0912	FRK16	AYPC.F50.0916 AYPC.F50.0912	AYPC.F50.0948-02 AYPC.F50.0949-02 2x8c.5,5x38 DIN 7981	100x50	x1	x2	x3	5,5x65/5,5x65
48 mm	FRK18	AYPC.F50.0916 AYPC.F50.0912	FRK15	AYPC.F50.0916 AYPC.F50.0912		100x50	x1	x2	x3	5,5x65/5,5x65
50 mm	FRK17	AYPC.F50.0916 AYPC.F50.0912	FRK14	AYPC.F50.0916 AYPC.F50.0912	100x50	x1	x2	x3	5,5x65/5,5x65	
52 mm	FRK19	AYPC.F50.0913	FRK16	AYPC.F50.0913	AYPC.F50.0948-03 AYPC.F50.0949-03 2x8c.5,5x45 DIN 7981	100x56	x1	x2	x3	5,5x70/5,5x70
54 mm	FRK18	AYPC.F50.0913	FRK15	AYPC.F50.0913		100x56	x1	x2	x3	5,5x70/5,5x70
56 mm	FRK17	AYPC.F50.0913	FRK14	AYPC.F50.0913		100x56	x1	x2	x3	5,5x70/5,5x70
58 mm	FRK19	AYPC.F50.0914	FRK16	AYPC.F50.0914	AYPC.F50.0952-03	100x62	x1	x2	x3	5,5x75/5,5x75
60 mm	FRK18	AYPC.F50.0914	FRK15	AYPC.F50.0914	AYPC.F50.0952-03	100x62	x1	x2	x3	5,5x75/5,5x75
62 mm	FRK17	AYPC.F50.0914	FRK14	AYPC.F50.0914	AYPC.F50.0952-03	100x62	x1	x2	x3	5,5x75/5,5x75

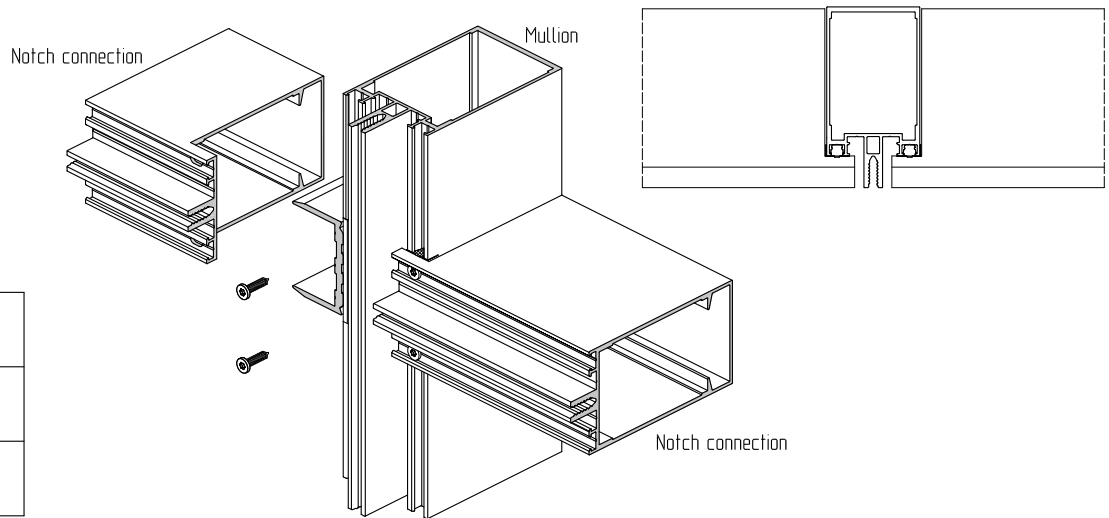

Curtain wall glazing in accordance with the type of profiles integrated

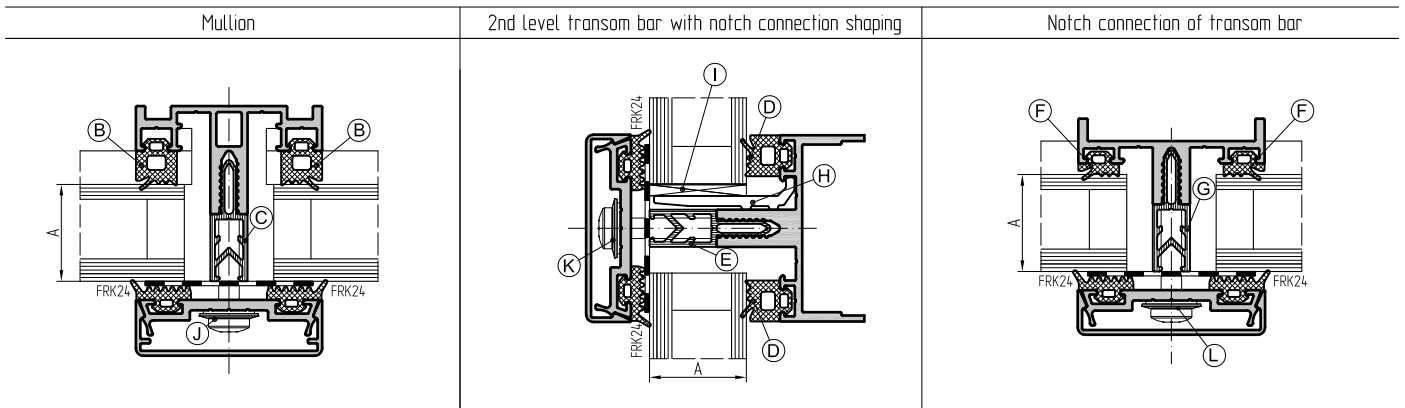

Glazing thickness	Gasket on the mullion	Thermal break on the mullion	Gasket on the 2nd level transom b. n. connection shaping	Thermal break on the 2nd level transom b. n. connection shaping	Gasket on the notch connection transom bar	Thermal break on the notch connection transom bar	Glass support			Self-tapp. screw Ø 5,5 DIN 7981		
							bearing	leveling				
A	B	C	D	E	F	G	H	I	x2	x3	J/K/L	
4 mm	FRK19	-	FRK19	-	FRK16	-	AYPC.F50.0940-01	100x12	x1	x2	x3	x22/x22/x22
5mm/6 mm	FRK18	-	FRK18	-	FRK15	-	AYPC.F50.0940-01	100x12	x1	x2	x3	x22/x22/x22
8 mm	FRK17	-	FRK17	-	FRK14	-	AYPC.F50.0940-01	100x12	x1	x2	x3	x22/x22/x22
22 mm	FRK19	AYPC.F50.0905 AYPC.F50.0908	FRK19	AYPC.F50.0905 AYPC.F50.0908	FRK16	AYPC.F50.0905 AYPC.F50.0908	AYPC.F50.0941-01	100x26	x1	x2	x3	x38/x38/x38
24 mm	FRK18	AYPC.F50.0905 AYPC.F50.0908	FRK18	AYPC.F50.0905 AYPC.F50.0908	FRK15	AYPC.F50.0905 AYPC.F50.0908	AYPC.F50.0941-01	100x26	x1	x2	x3	x38/x38/x38
26 mm	FRK17	AYPC.F50.0905 AYPC.F50.0908	FRK17	AYPC.F50.0905 AYPC.F50.0908	FRK14	AYPC.F50.0905 AYPC.F50.0908	AYPC.F50.0941-01	100x26	x1	x2	x3	x38/x38/x38
28 mm	FRK19	AYPC.F50.0906 AYPC.F50.0909	FRK19	AYPC.F50.0906 AYPC.F50.0909	FRK16	AYPC.F50.0906 AYPC.F50.0909	AYPC.F50.0941-02	100x32	x1	x2	x3	x45/x45/x45
30 mm	FRK18	AYPC.F50.0906 AYPC.F50.0909	FRK18	AYPC.F50.0906 AYPC.F50.0909	FRK15	AYPC.F50.0906 AYPC.F50.0909	AYPC.F50.0941-02	100x32	x1	x2	x3	x45/x45/x45
32 mm	FRK17	AYPC.F50.0906 AYPC.F50.0909	FRK17	AYPC.F50.0906 AYPC.F50.0909	FRK14	AYPC.F50.0906 AYPC.F50.0909	AYPC.F50.0941-02	100x32	x1	x2	x3	x45/x45/x45
34 mm	FRK19	AYPC.F50.0907 AYPC.F50.0910	FRK19	AYPC.F50.0907 AYPC.F50.0910	FRK16	AYPC.F50.0907 AYPC.F50.0910	AYPC.F50.0952	100x38	x1	x2	x3	x55/x55/x55
36 mm	FRK18	AYPC.F50.0907 AYPC.F50.0910	FRK18	AYPC.F50.0907 AYPC.F50.0910	FRK15	AYPC.F50.0907 AYPC.F50.0910	AYPC.F50.0952	100x38	x1	x2	x3	x55/x55/x55
38 mm	FRK17	AYPC.F50.0907 AYPC.F50.0910	FRK17	AYPC.F50.0907 AYPC.F50.0910	FRK14	AYPC.F50.0907 AYPC.F50.0910	AYPC.F50.0952	100x38	x1	x2	x3	x55/x55/x55
40 mm	FRK19	AYPC.F50.0911	FRK19	AYPC.F50.0911	FRK16	AYPC.F50.0911	AYPC.F50.0952-01	100x44	x1	x2	x3	x60/x60/x60
42 mm	FRK18	AYPC.F50.0911	FRK18	AYPC.F50.0911	FRK15	AYPC.F50.0911	AYPC.F50.0952-01	100x44	x1	x2	x3	x60/x60/x60
44 mm	FRK17	AYPC.F50.0911	FRK17	AYPC.F50.0911	FRK14	AYPC.F50.0911	AYPC.F50.0952-01	100x44	x1	x2	x3	x60/x60/x60
46 mm	FRK19	AYPC.F50.0912	FRK19	AYPC.F50.0912	FRK16	AYPC.F50.0912	AYPC.F50.0952-02	100x50	x1	x2	x3	x65/x65/x65
48 mm	FRK18	AYPC.F50.0912	FRK18	AYPC.F50.0912	FRK15	AYPC.F50.0912	AYPC.F50.0952-02	100x50	x1	x2	x3	x65/x65/x65
50 mm	FRK17	AYPC.F50.0912	FRK17	AYPC.F50.0912	FRK14	AYPC.F50.0912	AYPC.F50.0952-02	100x50	x1	x2	x3	x65/x65/x65
52 mm	FRK19	AYPC.F50.0913	FRK19	AYPC.F50.0913	FRK16	AYPC.F50.0913	AYPC.F50.0952-03	100x56	x1	x2	x3	x70/x70/x70
54 mm	FRK18	AYPC.F50.0913	FRK18	AYPC.F50.0913	FRK15	AYPC.F50.0913	AYPC.F50.0952-03	100x56	x1	x2	x3	x70/x70/x70
56 mm	FRK17	AYPC.F50.0913	FRK17	AYPC.F50.0913	FRK14	AYPC.F50.0913	AYPC.F50.0952-03	100x56	x1	x2	x3	x70/x70/x70

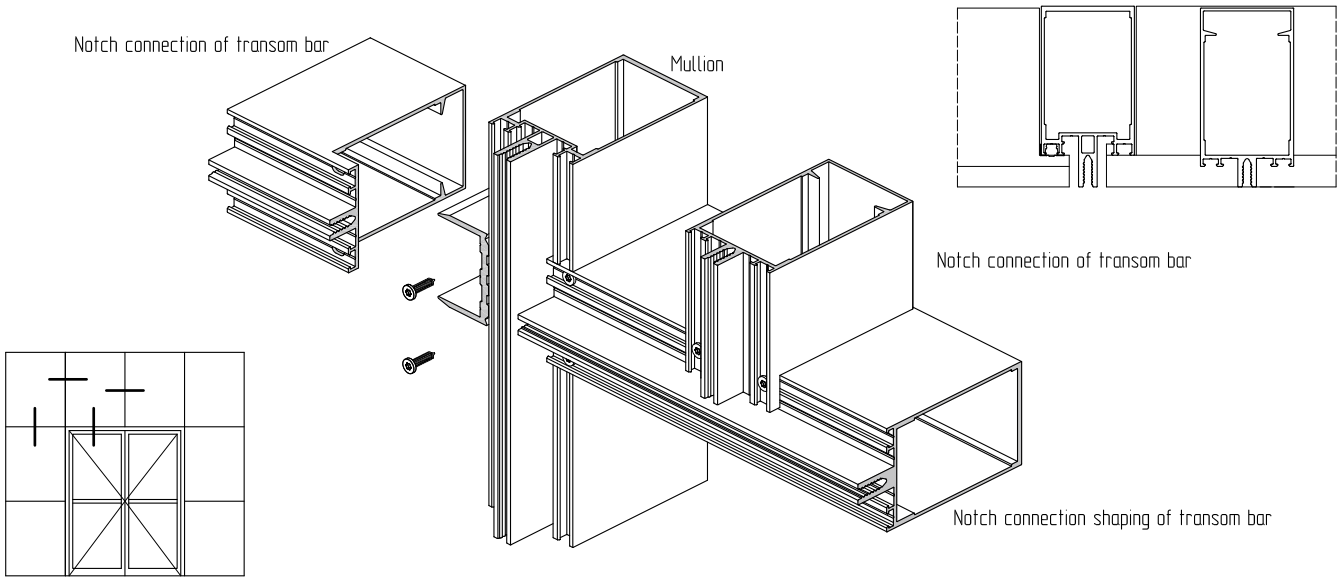

Curtain wall glazing depending on the type of profiles integrated

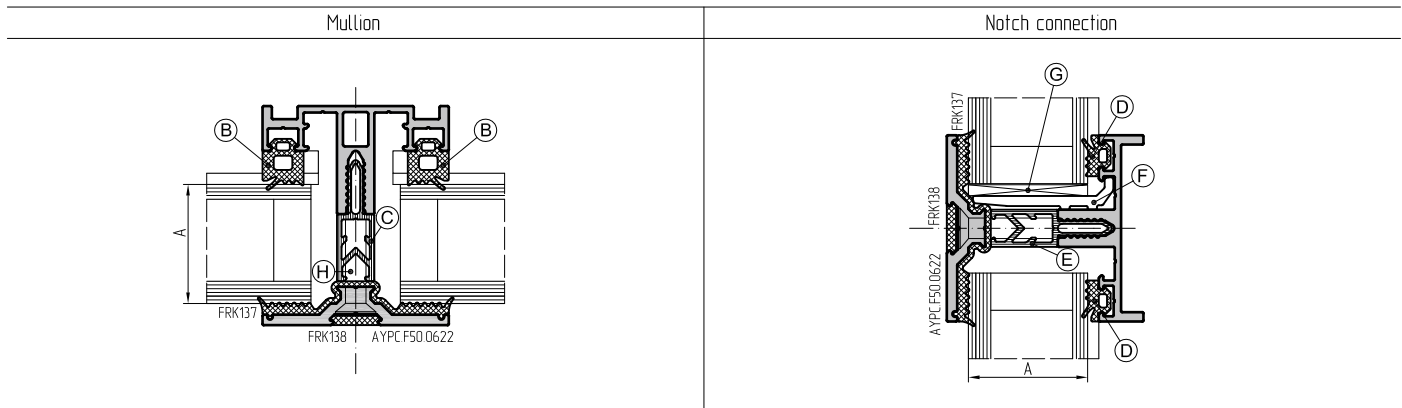

Glazing thickness	Mullion gasket	Mullion thermal break	Notch connection transom gasket	Notch connection transom thermal break	Glass support			Self-tapping screw Ø 5,5 DIN 7982		
					bearing	leveling				
A	B	C	D	E	F	G			H/I	
4 mm	AYPC.F50.0701+FRK19	-	FRK19	-	AYPC.F50.0940-01	FRK13	1 mm			5,5x22/5,5x22
5 mm/6 mm	AYPC.F50.0701+FRK18	-	FRK18	-	AYPC.F50.0940-01	FRK13	1 mm			5,5x22/5,5x22
8 mm	AYPC.F50.0701+FRK17	-	FRK17	-	AYPC.F50.0940-01	FRK13	1 mm			5,5x22/5,5x22
28 mm	FRK19	AYPC.F50.0905 AYPC.F50.0908	FRK16	AYPC.F50.0905 AYPC.F50.0908	AYPC.F50.0941-01	100x32	x1	x2	x3	5,5x38/5,5x38
30 mm	FRK18	AYPC.F50.0905 AYPC.F50.0908	FRK15	AYPC.F50.0905 AYPC.F50.0908	AYPC.F50.0941-01	100x32	x1	x2	x3	5,5x38/5,5x38
32 mm	FRK17	AYPC.F50.0905 AYPC.F50.0908	FRK14	AYPC.F50.0905 AYPC.F50.0908	AYPC.F50.0941-01	100x32	x1	x2	x3	5,5x38/5,5x38
34 mm	FRK19	AYPC.F50.0906 AYPC.F50.0909	FRK16	AYPC.F50.0906 AYPC.F50.0909	AYPC.F50.0941-02	100x38	x1	x2	x3	5,5x45/5,5x45
36 mm	FRK18	AYPC.F50.0906 AYPC.F50.0909	FRK15	AYPC.F50.0906 AYPC.F50.0909	AYPC.F50.0941-02	100x38	x1	x2	x3	5,5x45/5,5x45
38 mm	FRK17	AYPC.F50.0906 AYPC.F50.0909	FRK14	AYPC.F50.0906 AYPC.F50.0909	AYPC.F50.0941-02	100x38	x1	x2	x3	5,5x45/5,5x45
40 mm	FRK19	AYPC.F50.0907 AYPC.F50.0910	FRK16	AYPC.F50.0907 AYPC.F50.0910	AYPC.F50.0948-01 AYPC.F50.0949-01 2xØc 5,5x35 ISO 4762	100x44	x1	x2	x3	5,5x50/5,5x50
42 mm	FRK18	AYPC.F50.0907 AYPC.F50.0910	FRK15	AYPC.F50.0907 AYPC.F50.0910		100x44	x1	x2	x3	5,5x50/5,5x50
44 mm	FRK17	AYPC.F50.0907 AYPC.F50.0910	FRK14	AYPC.F50.0907 AYPC.F50.0910	100x44	x1	x2	x3	5,5x50/5,5x50	
46 mm	FRK19	AYPC.F50.0915 AYPC.F50.0911	FRK16	AYPC.F50.0915 AYPC.F50.0911	AYPC.F50.0948-02 AYPC.F50.0949-02 2xØc 5,5x38 DIN 7981	100x50	x1	x2	x3	5,5x55/5,5x55
48 mm	FRK18	AYPC.F50.0915 AYPC.F50.0911	FRK15	AYPC.F50.0915 AYPC.F50.0911		100x50	x1	x2	x3	5,5x55/5,5x55
50 mm	FRK17	AYPC.F50.0915 AYPC.F50.0911	FRK14	AYPC.F50.0915 AYPC.F50.0911	100x50	x1	x2	x3	5,5x55/5,5x55	
52 mm	FRK19	AYPC.F50.0916 AYPC.F50.0912	FRK16	AYPC.F50.0916 AYPC.F50.0912	AYPC.F50.0948-03 AYPC.F50.0949-03 2xØc 5,5x45 DIN 7981	100x56	x1	x2	x3	5,5x60/5,5x60
54 mm	FRK18	AYPC.F50.0916 AYPC.F50.0912	FRK15	AYPC.F50.0916 AYPC.F50.0912		100x56	x1	x2	x3	5,5x60/5,5x60
56 mm	FRK17	AYPC.F50.0916 AYPC.F50.0912	FRK14	AYPC.F50.0916 AYPC.F50.0912	100x56	x1	x2	x3	5,5x60/5,5x60	

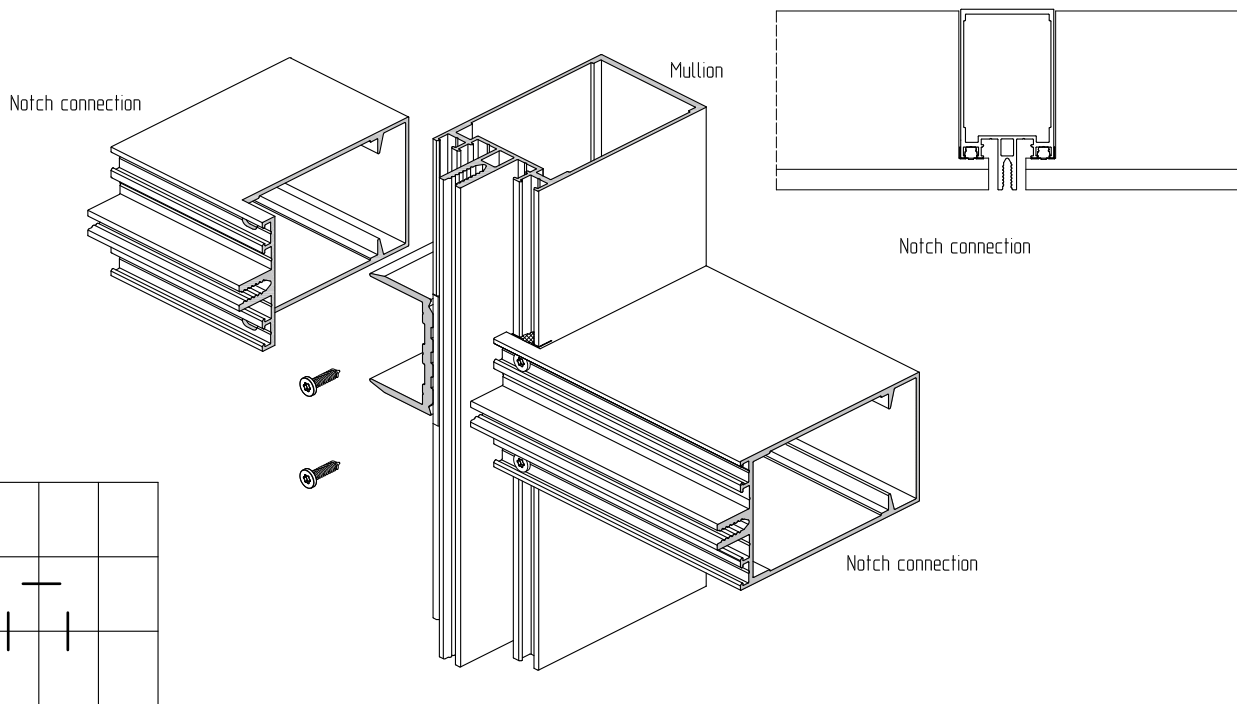

Curtain wall glazing in accordance with the type of profiles integrated

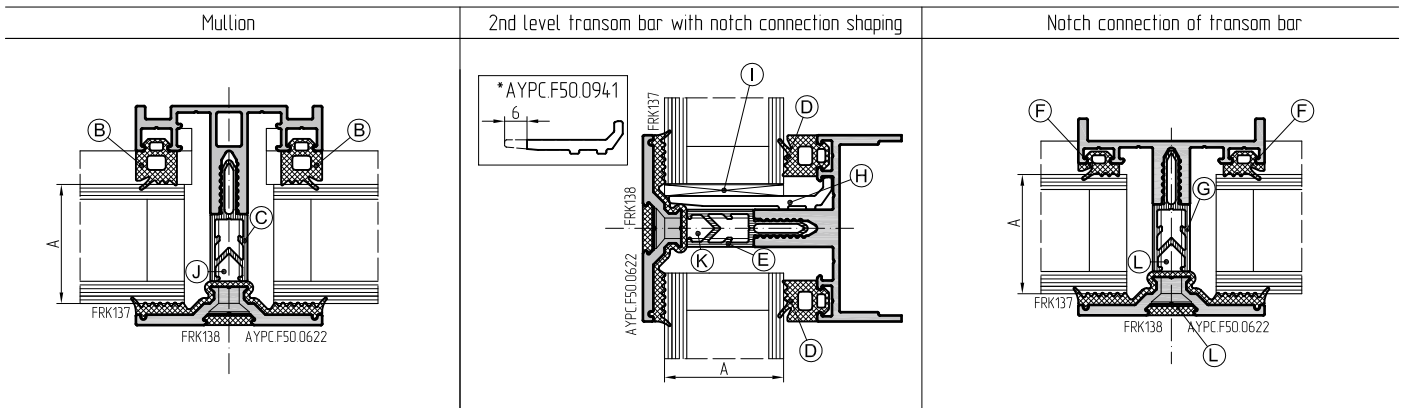

Glazing thickness	Gasket on the mullion	Thermal break on the mullion	Gasket on the 2nd level transom bar n. connection shaping	Thermal break on the 2nd level transom bar n. connection shaping	Gasket on the notch connection transom bar	Thermal break on the notch connection transom bar	Glass support			Self-tapp screw ø 5,5 DIN 7981
							bearing	leveling		
A	B	C	D	E	F	G	H	I	J/K/L	
4 MM	AYPC.F50.0701+FRK19	-	AYPC.F50.0701+FRK19	-	FRK19	-	*AYPC.F50.0941	FRK13	1 MM	x22/x22/x22
5MM/6 MM	AYPC.F50.0701+FRK18	-	AYPC.F50.0701+FRK18	-	FRK18	-	*AYPC.F50.0941	FRK13	1 MM	x22/x22/x22
8 MM	AYPC.F50.0701+FRK17	-	AYPC.F50.0701+FRK17	-	FRK17	-	*AYPC.F50.0941	FRK13	1 MM	x22/x22/x22
28 MM	FRK19	AYPC.F50.0905 AYPC.F50.0908	FRK19	AYPC.F50.0905 AYPC.F50.0908	FRK16	AYPC.F50.0905 AYPC.F50.0908	AYPC.F50.0941-02	100x32	x1 x2 x3	x38/x38/x38
30 MM	FRK18	AYPC.F50.0905 AYPC.F50.0908	FRK18	AYPC.F50.0905 AYPC.F50.0908	FRK15	AYPC.F50.0905 AYPC.F50.0908	AYPC.F50.0941-02	100x32	x1 x2 x3	x38/x38/x38
32 MM	FRK17	AYPC.F50.0905 AYPC.F50.0908	FRK17	AYPC.F50.0905 AYPC.F50.0908	FRK14	AYPC.F50.0905 AYPC.F50.0908	AYPC.F50.0941-02	100x32	x1 x2 x3	x38/x38/x38
34 MM	FRK19	AYPC.F50.0906 AYPC.F50.0909	FRK19	AYPC.F50.0906 AYPC.F50.0909	FRK16	AYPC.F50.0906 AYPC.F50.0909	AYPC.F50.0952	100x38	x1 x2 x3	x45/x45/x45
36 MM	FRK18	AYPC.F50.0906 AYPC.F50.0909	FRK18	AYPC.F50.0906 AYPC.F50.0909	FRK15	AYPC.F50.0906 AYPC.F50.0909	AYPC.F50.0952	100x38	x1 x2 x3	x45/x45/x45
38 MM	FRK17	AYPC.F50.0906 AYPC.F50.0909	FRK17	AYPC.F50.0906 AYPC.F50.0909	FRK14	AYPC.F50.0906 AYPC.F50.0909	AYPC.F50.0952	100x38	x1 x2 x3	x45/x45/x45
40 MM	FRK19	AYPC.F50.0907 AYPC.F50.0910	FRK19	AYPC.F50.0907 AYPC.F50.0910	FRK16	AYPC.F50.0907 AYPC.F50.0910	AYPC.F50.0952-01	100x44	x1 x2 x3	x55/x55/x55
42 MM	FRK18	AYPC.F50.0907 AYPC.F50.0910	FRK18	AYPC.F50.0907 AYPC.F50.0910	FRK15	AYPC.F50.0907 AYPC.F50.0910	AYPC.F50.0952-01	100x44	x1 x2 x3	x55/x55/x55
44 MM	FRK17	AYPC.F50.0907 AYPC.F50.0910	FRK17	AYPC.F50.0907 AYPC.F50.0910	FRK14	AYPC.F50.0907 AYPC.F50.0910	AYPC.F50.0952-01	100x44	x1 x2 x3	x55/x55/x55
46 MM	FRK19	AYPC.F50.0915 AYPC.F50.0911	FRK19	AYPC.F50.0915 AYPC.F50.0911	FRK16	AYPC.F50.0915 AYPC.F50.0911	AYPC.F50.0952-02	100x50	x1 x2 x3	x60/x60/x60
48 MM	FRK18	AYPC.F50.0915 AYPC.F50.0911	FRK18	AYPC.F50.0915 AYPC.F50.0911	FRK15	AYPC.F50.0915 AYPC.F50.0911	AYPC.F50.0952-02	100x50	x1 x2 x3	x60/x60/x60
50 MM	FRK17	AYPC.F50.0915 AYPC.F50.0911	FRK17	AYPC.F50.0915 AYPC.F50.0911	FRK14	AYPC.F50.0915 AYPC.F50.0911	AYPC.F50.0952-02	100x50	x1 x2 x3	x60/x60/x60
52 MM	FRK19	AYPC.F50.0916 AYPC.F50.0912	FRK19	AYPC.F50.0916 AYPC.F50.0912	FRK16	AYPC.F50.0916 AYPC.F50.0912	AYPC.F50.0952-03	100x56	x1 x2 x3	x65/x65/x65
54 MM	FRK18	AYPC.F50.0916 AYPC.F50.0912	FRK18	AYPC.F50.0916 AYPC.F50.0912	FRK15	AYPC.F50.0916 AYPC.F50.0912	AYPC.F50.0952-03	100x56	x1 x2 x3	x65/x65/x65
56 MM	FRK17	AYPC.F50.0916 AYPC.F50.0912	FRK17	AYPC.F50.0916 AYPC.F50.0912	FRK14	AYPC.F50.0916 AYPC.F50.0912	AYPC.F50.0952-03	100x56	x1 x2 x3	x65/x65/x65

Notch connection of transom bar

Mullion

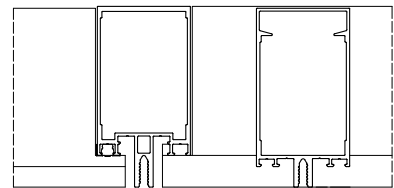

Notch connection of transom bar

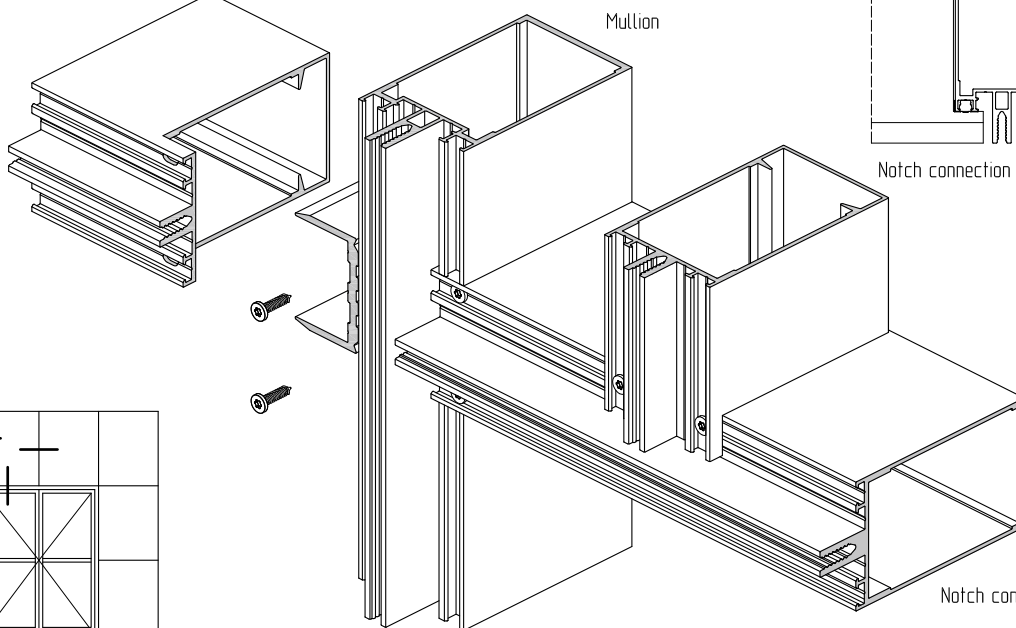
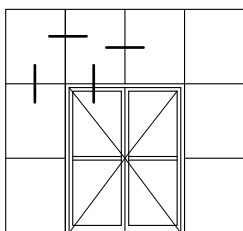

Notch connection shaping of transom bar



Inclined curtain wall glazing

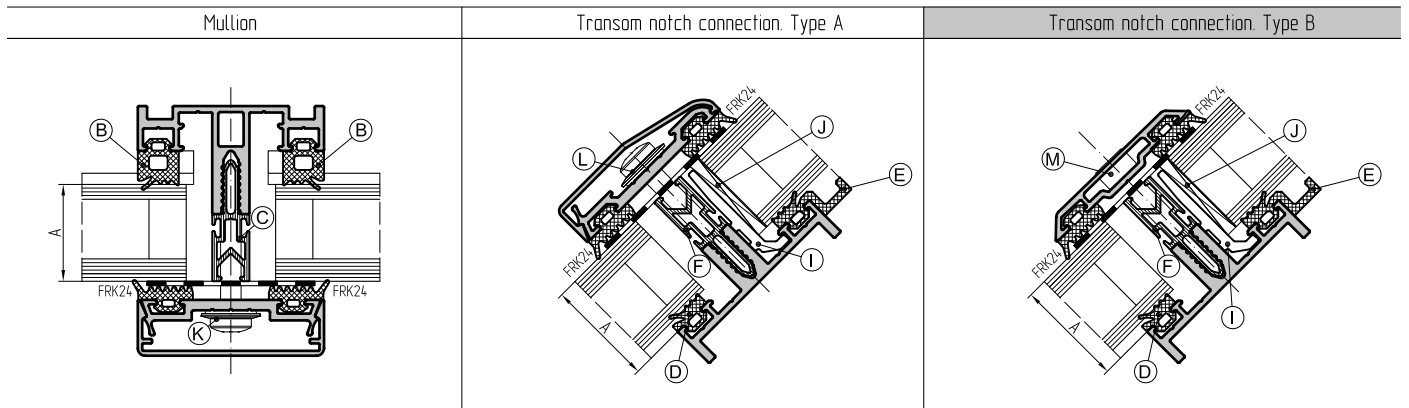

Glazing thickness	Mullion gasket	Mullion thermal break	Notch connection transom gasket Type A	Notch connection transom gasket Type B	Notch connection transom thermal break	Glass support			Type A	Type B		
						bearing	leveling		Self-tapping screw ø 5,5 DIN 7981	Self-tapping screw * ø 5,5 ISO 4762		
A	B	C	D/E	D/E	F	I	J		K/L	K/ M		
4 mm	FRK19	-	FRK16/FRK22	FRK16/FRK22	-	AYPC.F50.0940	FRK13	1 mm		x19/x19	x22/*x22	
6 mm	FRK18	-	FRK15/FRK21	FRK15/FRK21	-	AYPC.F50.0940	FRK13	1 mm		x19/x19	x22/*x22	
8 mm	FRK17	-	FRK14/FRK20	FRK14/FRK20	-	AYPC.F50.0940	FRK13	1 mm		x19/x19	x22/*x22	
22 mm	FRK19	AYPC.F50.0905 AYPC.F50.0908	FRK16/FRK22	FRK16/FRK22	AYPC.F50.0905 AYPC.F50.0908	AYPC.F50.0941	100x26	x1	x2	x3	x38/x38	x38/*x35
24 mm	FRK18	AYPC.F50.0905 AYPC.F50.0908	FRK15/FRK21	FRK15/FRK21	AYPC.F50.0905 AYPC.F50.0908	AYPC.F50.0941	100x26	x1	x2	x3	x38/x38	x38/*x35
26 mm	FRK17	AYPC.F50.0905 AYPC.F50.0908	FRK14/FRK20	FRK14/FRK20	AYPC.F50.0905 AYPC.F50.0908	AYPC.F50.0941	100x26	x1	x2	x3	x38/x38	x38/*x35
28 mm	FRK19	AYPC.F50.0906 AYPC.F50.0909	FRK16/FRK22	FRK16/FRK22	AYPC.F50.0906 AYPC.F50.0909	AYPC.F50.0941-01	100x32	x1	x2	x3	x45/x45	x45/*x42
30 mm	FRK18	AYPC.F50.0906 AYPC.F50.0909	FRK15/FRK21	FRK15/FRK21	AYPC.F50.0906 AYPC.F50.0909	AYPC.F50.0941-01	100x32	x1	x2	x3	x45/x45	x45/*x42
32 mm	FRK17	AYPC.F50.0906 AYPC.F50.0909	FRK14/FRK20	FRK14/FRK20	AYPC.F50.0906 AYPC.F50.0909	AYPC.F50.0941-01	100x32	x1	x2	x3	x45/x45	x45/*x42
34 mm	FRK19	AYPC.F50.0907 AYPC.F50.0910	FRK16/FRK22	FRK16/FRK22	AYPC.F50.0907 AYPC.F50.0910	AYPC.F50.0941-02	100x38	x1	x2	x3	x55/x55	x55/*x48
36 mm	FRK18	AYPC.F50.0907 AYPC.F50.0910	FRK15/FRK21	FRK15/FRK21	AYPC.F50.0907 AYPC.F50.0910	AYPC.F50.0941-02	100x38	x1	x2	x3	x55/x55	x55/*x48
38 mm	FRK17	AYPC.F50.0907 AYPC.F50.0910	FRK14/FRK20	FRK14/FRK20	AYPC.F50.0907 AYPC.F50.0910	AYPC.F50.0941-02	100x38	x1	x2	x3	x55/x55	x55/*x48
40 mm	FRK19	AYPC.F50.0911	FRK16/FRK22	FRK16/FRK22	AYPC.F50.0911	AYPC.F50.0952	100x44	x1	x2	x3	x60/x60	x60/*x55
42 mm	FRK18	AYPC.F50.0911	FRK15/FRK21	FRK15/FRK21	AYPC.F50.0911	AYPC.F50.0952	100x44	x1	x2	x3	x60/x60	x60/*x55
44 mm	FRK17	AYPC.F50.0911	FRK14/FRK20	FRK14/FRK20	AYPC.F50.0911	AYPC.F50.0952	100x44	x1	x2	x3	x60/x60	x60/*x55
46 mm	FRK19	AYPC.F50.0912	FRK16/FRK22	FRK16/FRK22	AYPC.F50.0912	AYPC.F50.0952-01	100x50	x1	x2	x3	x65/x65	x65/*x60
48 mm	FRK18	AYPC.F50.0912	FRK15/FRK21	FRK15/FRK21	AYPC.F50.0912	AYPC.F50.0952-01	100x50	x1	x2	x3	x65/x65	x65/*x60
50 mm	FRK17	AYPC.F50.0912	FRK14/FRK20	FRK14/FRK20	AYPC.F50.0912	AYPC.F50.0952-01	100x50	x1	x2	x3	x65/x65	x65/*x60
52 mm	FRK19	AYPC.F50.0913	FRK16/FRK22	FRK16/FRK22	AYPC.F50.0913	AYPC.F50.0952-02	100x56	x1	x2	x3	x70/x70	x70/*x65
54 mm	FRK18	AYPC.F50.0913	FRK15/FRK21	FRK15/FRK21	AYPC.F50.0913	AYPC.F50.0952-02	100x56	x1	x2	x3	x70/x70	x70/*x65
56 mm	FRK17	AYPC.F50.0913	FRK14/FRK20	FRK14/FRK20	AYPC.F50.0913	AYPC.F50.0952-02	100x56	x1	x2	x3	x70/x70	x70/*x65

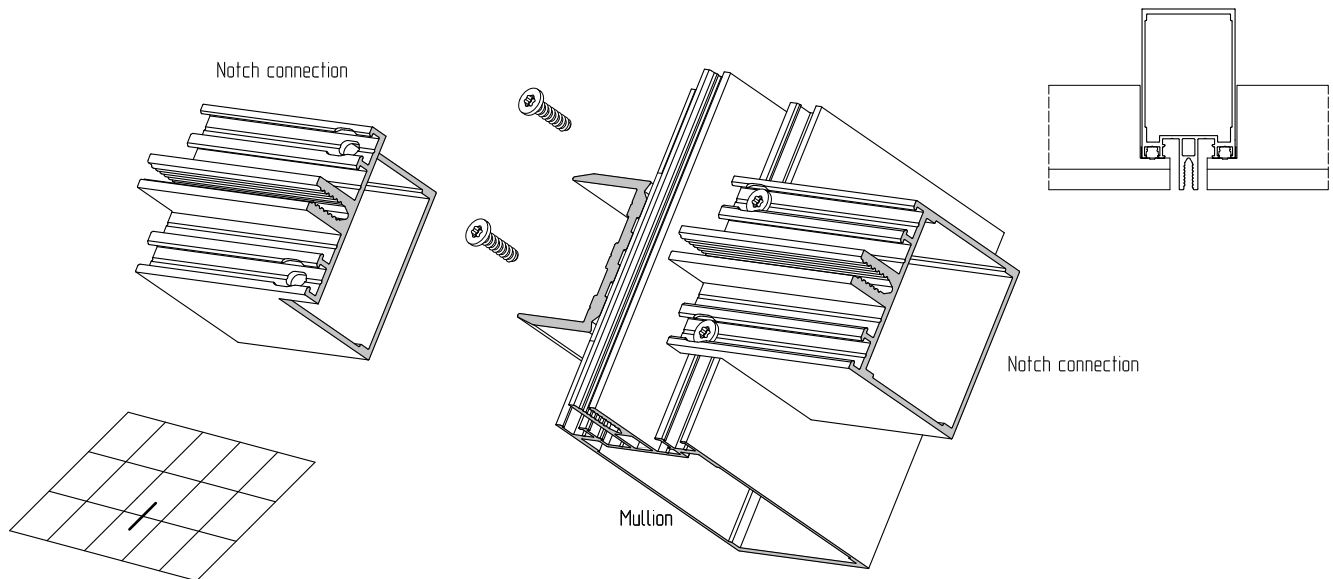

Curtain wall glazing for exterior reversible angles depending on the type of profiles integrated

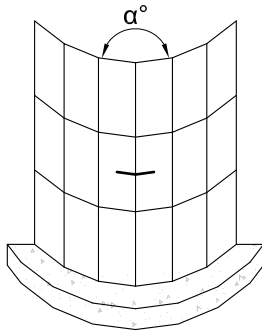

Mullion with reversible angle

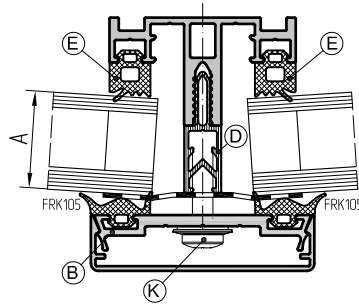

Transom notch connection

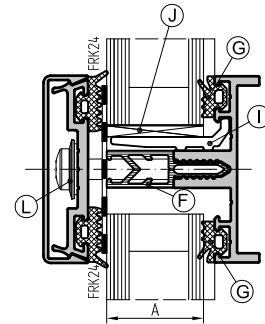

Glass thickness	Angle of turn	Clamping bar	Corner adapter	Thermal break on the mullion	Gasket on the mullion	Thermal break on the transom	Gasket on the transom	Glass support				Self-tapping screw 5,5 DIN 7981	
								bearing		levelling			
A	$\alpha^\circ$	B	C	D	E	F	G	I	J			K/L	
22	172,5°-180°	AYPC.F50.6009	-	AYPC.F50.0905 AYPC.F50.0908	FRK 19	AYPC.F50.0905 AYPC.F50.0908	FRK 16	AYPC.F50.0941	100x26	x1	x2	x3	x38/38
24	172,5°-180°	AYPC.F50.6009	-	AYPC.F50.0905 AYPC.F50.0908	FRK 18	AYPC.F50.0905 AYPC.F50.0908	FRK 15	AYPC.F50.0941	100x26	x1	x2	x3	x38/38
26	172,5°-180°	AYPC.F50.6009	-	AYPC.F50.0905 AYPC.F50.0908	FRK 17	AYPC.F50.0905 AYPC.F50.0908	FRK 14	AYPC.F50.0941	100x26	x1	x2	x3	x38/38
28	172,5°-180°	AYPC.F50.6009	-	AYPC.F50.0906 AYPC.F50.0909	FRK 19	AYPC.F50.0906 AYPC.F50.0909	FRK 16	AYPC.F50.0941-01	100x32	x1	x2	x3	x45/45
30	172,5°-180°	AYPC.F50.6009	-	AYPC.F50.0906 AYPC.F50.0909	FRK 18	AYPC.F50.0906 AYPC.F50.0909	FRK 15	AYPC.F50.0941-01	100x32	x1	x2	x3	x45/45
32	172,5°-180°	AYPC.F50.6009	-	AYPC.F50.0906 AYPC.F50.0909	FRK 17	AYPC.F50.0906 AYPC.F50.0909	FRK 14	AYPC.F50.0941-01	100x32	x1	x2	x3	x45/45
34	172,5°-180°	AYPC.F50.6009	-	AYPC.F50.0907 AYPC.F50.0910	FRK 19	AYPC.F50.0907 AYPC.F50.0910	FRK 16	AYPC.F50.0941-02	100x38	x1	x2	x3	x55/55
36	172,5°-180°	AYPC.F50.6009	-	AYPC.F50.0907 AYPC.F50.0910	FRK 18	AYPC.F50.0907 AYPC.F50.0910	FRK 15	AYPC.F50.0941-02	100x38	x1	x2	x3	x55/55
38	172,5°-180°	AYPC.F50.6009	-	AYPC.F50.0907 AYPC.F50.0910	FRK 17	AYPC.F50.0907 AYPC.F50.0910	FRK 14	AYPC.F50.0941-02	100x38	x1	x2	x3	x55/55
40	172,5°-180°	AYPC.F50.6009	-	AYPC.F50.0915 AYPC.F50.0911	FRK 19	AYPC.F50.0915 AYPC.F50.0911	FRK 16	AYPC.F50.0948-01 AYPC.F50.0949-01	100x44	x1	x2	x3	x60/x60
42	172,5°-180°	AYPC.F50.6009	-	AYPC.F50.0915 AYPC.F50.0911	FRK 18	AYPC.F50.0915 AYPC.F50.0911	FRK 15		100x44	x1	x2	x3	x60/x60
44	172,5°-180°	AYPC.F50.6009	-	AYPC.F50.0915 AYPC.F50.0911	FRK 17	AYPC.F50.0915 AYPC.F50.0911	FRK 14	2x6c5,5x35 ISO 4762	100x44	x1	x2	x3	x60/x60
46	172,5°-180°	AYPC.F50.6009	-	AYPC.F50.0916 AYPC.F50.0912	FRK 19	AYPC.F50.0916 AYPC.F50.0912	FRK 16	AYPC.F50.0948-02 AYPC.F50.0949-02	100x50	x1	x2	x3	x65/x65
48	172,5°-180°	AYPC.F50.6009	-	AYPC.F50.0916 AYPC.F50.0912	FRK 18	AYPC.F50.0916 AYPC.F50.0912	FRK 15		100x50	x1	x2	x3	x65/x65
50	172,5°-180°	AYPC.F50.6009	-	AYPC.F50.0916 AYPC.F50.0912	FRK 17	AYPC.F50.0916 AYPC.F50.0912	FRK 14	2x6c5,5x38 DIN 7981	100x50	x1	x2	x3	x65/x65
52	172,5°-180°	AYPC.F50.6009	-	AYPC.F50.0913	FRK 19	AYPC.F50.0913	FRK 16	AYPC.F50.0948-03 AYPC.F50.0949-03	100x56	x1	x2	x3	x70/x70
54	172,5°-180°	AYPC.F50.6009	-	AYPC.F50.0913	FRK 18	AYPC.F50.0913	FRK 15		100x56	x1	x2	x3	x70/x70
56	172,5°-180°	AYPC.F50.6009	-	AYPC.F50.0913	FRK 17	AYPC.F50.0913	FRK 14	2x6c5,5x45 DIN 7981	100x56	x1	x2	x3	x70/x70
58	172,5°-180°	AYPC.F50.6009	-	AYPC.F50.0914	FRK 19	AYPC.F50.0914	FRK 16	AYPC.F50.0953 AYPC.F50.0952-03	100x62	x1	x2	x3	x80/x80
60	172,5°-180°	AYPC.F50.6009	-	AYPC.F50.0914	FRK 18	AYPC.F50.0914	FRK 15		100x62	x1	x2	x3	x80/x80
62	172,5°-180°	AYPC.F50.6009	-	AYPC.F50.0914	FRK 17	AYPC.F50.0914	FRK 14		100x62	x1	x2	x3	x80/x80

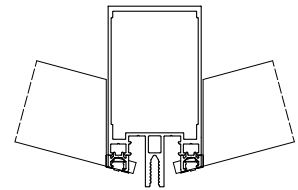
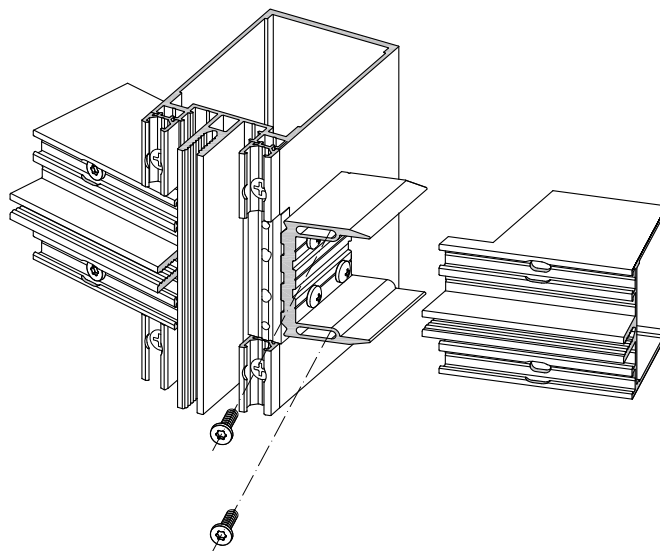

01  
02  
03  
04  
05  
06  
07  
08  
09  
10  
11  
12  
13

Curtain wall glazing for exterior reversible angles depending on the type of profiles integrated

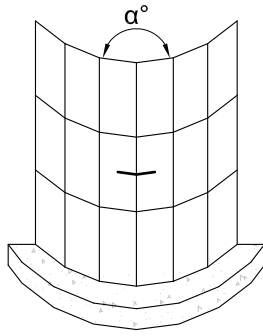

Mullion with reversible angle

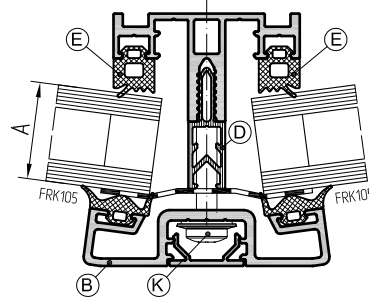

Transom notch connection

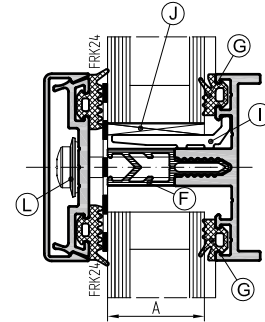

Glass thickness	Angle of turn	Clamping bar	Corner adapter	Thermal break on the mullion	Gasket on the mullion	Thermal break on the transom	Gasket on the transom	Glass support			Self-tapping screw 5,5 DIN 7981		
								bearing	levelling				
A	$\alpha^\circ$	B	C	D	E	F	G	I	J	K/L			
22	165°-172,5°	AYPC.F50.0614	-	AYPC.F50.0905 AYPC.F50.0908	FRK 19	AYPC.F50.0905 AYPC.F50.0908	FRK 16	AYPC.F50.0941	100x26	x1	x2	x3	x38/38
24	165°-172,5°	AYPC.F50.0614	-	AYPC.F50.0905 AYPC.F50.0908	FRK 18	AYPC.F50.0905 AYPC.F50.0908	FRK 15	AYPC.F50.0941	100x26	x1	x2	x3	x38/38
26	165°-172,5°	AYPC.F50.0614	-	AYPC.F50.0905 AYPC.F50.0908	FRK 17	AYPC.F50.0905 AYPC.F50.0908	FRK 14	AYPC.F50.0941	100x26	x1	x2	x3	x38/38
28	165°-172,5°	AYPC.F50.0614	-	AYPC.F50.0906 AYPC.F50.0909	FRK 19	AYPC.F50.0906 AYPC.F50.0909	FRK 16	AYPC.F50.0941-01	100x32	x1	x2	x3	x45/45
30	165°-172,5°	AYPC.F50.0614	-	AYPC.F50.0906 AYPC.F50.0909	FRK 18	AYPC.F50.0906 AYPC.F50.0909	FRK 15	AYPC.F50.0941-01	100x32	x1	x2	x3	x45/45
32	165°-172,5°	AYPC.F50.0614	-	AYPC.F50.0906 AYPC.F50.0909	FRK 17	AYPC.F50.0906 AYPC.F50.0909	FRK 14	AYPC.F50.0941-01	100x32	x1	x2	x3	x45/45
34	165°-172,5°	AYPC.F50.0614	-	AYPC.F50.0907 AYPC.F50.0910	FRK 19	AYPC.F50.0907 AYPC.F50.0910	FRK 16	AYPC.F50.0941-02	100x38	x1	x2	x3	x55/55
36	165°-172,5°	AYPC.F50.0614	-	AYPC.F50.0907 AYPC.F50.0910	FRK 18	AYPC.F50.0907 AYPC.F50.0910	FRK 15	AYPC.F50.0941-02	100x38	x1	x2	x3	x55/55
38	165°-172,5°	AYPC.F50.0614	-	AYPC.F50.0907 AYPC.F50.0910	FRK 17	AYPC.F50.0907 AYPC.F50.0910	FRK 14	AYPC.F50.0941-02	100x38	x1	x2	x3	x55/55
40	165°-172,5°	AYPC.F50.0614	-	AYPC.F50.0915 AYPC.F50.0911	FRK 19	AYPC.F50.0915 AYPC.F50.0911	FRK 16	AYPC.F50.0948-01 AYPC.F50.0949-01	100x44	x1	x2	x3	x60/x60
42	165°-172,5°	AYPC.F50.0614	-	AYPC.F50.0915 AYPC.F50.0911	FRK 18	AYPC.F50.0915 AYPC.F50.0911	FRK 15		100x44	x1	x2	x3	x60/x60
44	165°-172,5°	AYPC.F50.0614	-	AYPC.F50.0915 AYPC.F50.0911	FRK 17	AYPC.F50.0915 AYPC.F50.0911	FRK 14	2x6c5,5x35 ISO 4762	100x44	x1	x2	x3	x60/x60
46	165°-172,5°	AYPC.F50.0614	-	AYPC.F50.0916 AYPC.F50.0912	FRK 19	AYPC.F50.0916 AYPC.F50.0912	FRK 16	AYPC.F50.0948-02 AYPC.F50.0949-02	100x50	x1	x2	x3	x65/x65
48	165°-172,5°	AYPC.F50.0614	-	AYPC.F50.0916 AYPC.F50.0912	FRK 18	AYPC.F50.0916 AYPC.F50.0912	FRK 15		100x50	x1	x2	x3	x65/x65
50	165°-172,5°	AYPC.F50.0614	-	AYPC.F50.0916 AYPC.F50.0912	FRK 17	AYPC.F50.0916 AYPC.F50.0912	FRK 14	2x6c5,5x38 DIN 7981	100x50	x1	x2	x3	x65/x65
52	165°-172,5°	AYPC.F50.0614	-	AYPC.F50.0913	FRK 19	AYPC.F50.0913	FRK 16	AYPC.F50.0948-03 AYPC.F50.0949-03	100x56	x1	x2	x3	x70/x70
54	165°-172,5°	AYPC.F50.0614	-	AYPC.F50.0913	FRK 18	AYPC.F50.0913	FRK 15		100x56	x1	x2	x3	x70/x70
	165°-172,5°	AYPC.F50.0614-01	-	AYPC.F50.0913	FRK 17	AYPC.F50.0913	FRK 14		100x56	x1	x2	x3	x70/x70
58	165°-172,5°	AYPC.F50.0614	-	AYPC.F50.0914	FRK 19	AYPC.F50.0914	FRK 16	AYPC.F50.0953 AYPC.F50.0952-03	100x62	x1	x2	x3	x80/x80
	165°-172,5°	AYPC.F50.0614-01	-	AYPC.F50.0914	FRK 18	AYPC.F50.0914	FRK 15		100x62	x1	x2	x3	x80/x80
62	165°-172,5°	AYPC.F50.0614	-	AYPC.F50.0914	FRK 17	AYPC.F50.0914	FRK 14		100x62	x1	x2	x3	x80/x80
	165°-172,5°	AYPC.F50.0614-01	-	AYPC.F50.0914	FRK 17	AYPC.F50.0914	FRK 14	100x62	x1	x2	x3	x80/x80	

Curtain wall glazing for exterior reversible angles depending on the type of profiles integrated

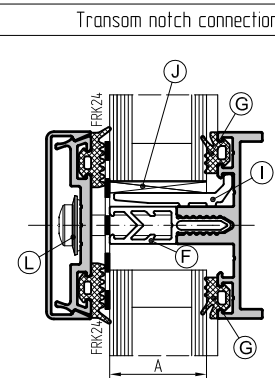
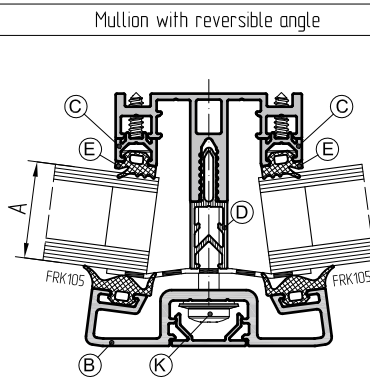
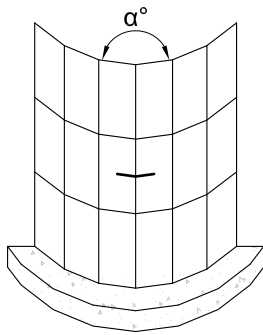

Glass thickness	Angle of turn	Clamping bar	Corner adapter +7,5°	Thermal break on the mullion	Gasket on the mullion	Thermal break on the transom	Gasket on the transom	Glass support				Self-tapping screw 5,5 DIN 7981	
								bearing		levelling			
A	$\alpha^\circ$	B	C	D	E	F	G	I	J			K/L	
22	157,5°-172,5°	AYPC.F50.0614	AYPC.F50.0712	AYPC.F50.0905 AYPC.F50.0908	FRK 16	AYPC.F50.0905 AYPC.F50.0908	FRK 16	AYPC.F50.0941	100x26	x1	x2	x3	x38/38
24	157,5°-172,5°	AYPC.F50.0614	AYPC.F50.0712	AYPC.F50.0905 AYPC.F50.0908	FRK 15	AYPC.F50.0905 AYPC.F50.0908	FRK 15	AYPC.F50.0941	100x26	x1	x2	x3	x38/38
26	157,5°-172,5°	AYPC.F50.0614	AYPC.F50.0712	AYPC.F50.0905 AYPC.F50.0908	FRK 14	AYPC.F50.0905 AYPC.F50.0908	FRK 14	AYPC.F50.0941	100x26	x1	x2	x3	x38/38
28	157,5°-172,5°	AYPC.F50.0614	AYPC.F50.0712	AYPC.F50.0906 AYPC.F50.0909	FRK 16	AYPC.F50.0906 AYPC.F50.0909	FRK 16	AYPC.F50.0941-01	100x32	x1	x2	x3	x45/45
30	157,5°-172,5°	AYPC.F50.0614	AYPC.F50.0712	AYPC.F50.0906 AYPC.F50.0909	FRK 15	AYPC.F50.0906 AYPC.F50.0909	FRK 15	AYPC.F50.0941-01	100x32	x1	x2	x3	x45/45
32	157,5°-172,5°	AYPC.F50.0614	AYPC.F50.0712	AYPC.F50.0906 AYPC.F50.0909	FRK 14	AYPC.F50.0906 AYPC.F50.0909	FRK 14	AYPC.F50.0941-01	100x32	x1	x2	x3	x45/45
34	157,5°-172,5°	AYPC.F50.0614	AYPC.F50.0712	AYPC.F50.0907 AYPC.F50.0910	FRK 16	AYPC.F50.0907 AYPC.F50.0910	FRK 16	AYPC.F50.0941-02	100x38	x1	x2	x3	x55/55
	157,5°-172,5°	AYPC.F50.0614-01	AYPC.F50.0712	AYPC.F50.0907 AYPC.F50.0910	FRK 15	AYPC.F50.0907 AYPC.F50.0910	FRK 15	AYPC.F50.0941-02	100x38	x1	x2	x3	
36	157,5°-172,5°	AYPC.F50.0614	AYPC.F50.0712	AYPC.F50.0907 AYPC.F50.0910	FRK 14	AYPC.F50.0907 AYPC.F50.0910	FRK 14	AYPC.F50.0941-02	100x38	x1	x2	x3	x55/55
	157,5°-172,5°	AYPC.F50.0614-01	AYPC.F50.0712	AYPC.F50.0907 AYPC.F50.0910	FRK 16	AYPC.F50.0907 AYPC.F50.0910	FRK 16	AYPC.F50.0941-02	100x38	x1	x2	x3	
38	157,5°-172,5°	AYPC.F50.0614	AYPC.F50.0712	AYPC.F50.0915 AYPC.F50.0911	FRK 16	AYPC.F50.0915 AYPC.F50.0911	FRK 16	AYPC.F50.0948-01 AYPC.F50.0949-01 2x8c5,5x35 ISO 4762	100x44	x1	x2	x3	x60/x60
	157,5°-172,5°	AYPC.F50.0614-01	AYPC.F50.0712	AYPC.F50.0915 AYPC.F50.0911	FRK 15	AYPC.F50.0915 AYPC.F50.0911	FRK 15		100x44	x1	x2	x3	
42	157,5°-172,5°	AYPC.F50.0614	AYPC.F50.0712	AYPC.F50.0916 AYPC.F50.0912	FRK 16	AYPC.F50.0916 AYPC.F50.0912	FRK 16	AYPC.F50.0948-02 AYPC.F50.0949-02 2x8c5,5x38 DIN 7981	100x44	x1	x2	x3	x60/x60
	157,5°-172,5°	AYPC.F50.0614-01	AYPC.F50.0712	AYPC.F50.0916 AYPC.F50.0912	FRK 14	AYPC.F50.0916 AYPC.F50.0912	FRK 14		100x44	x1	x2	x3	
44	157,5°-172,5°	AYPC.F50.0614	AYPC.F50.0712	AYPC.F50.0916 AYPC.F50.0912	FRK 15	AYPC.F50.0916 AYPC.F50.0912	FRK 15	AYPC.F50.0948-02 AYPC.F50.0949-02 2x8c5,5x38 DIN 7981	100x50	x1	x2	x3	x65/x65
	157,5°-172,5°	AYPC.F50.0614-01	AYPC.F50.0712	AYPC.F50.0916 AYPC.F50.0912	FRK 14	AYPC.F50.0916 AYPC.F50.0912	FRK 14		100x50	x1	x2	x3	
46	157,5°-172,5°	AYPC.F50.0614	AYPC.F50.0712	AYPC.F50.0913	FRK 16	AYPC.F50.0913	FRK 16	AYPC.F50.0948-03 AYPC.F50.0949-03 2x8c5,5x45 DIN 7981	100x50	x1	x2	x3	x65/x65
	157,5°-172,5°	AYPC.F50.0614-01	AYPC.F50.0712	AYPC.F50.0913	FRK 15	AYPC.F50.0913	FRK 15		100x50	x1	x2	x3	
48	157,5°-172,5°	AYPC.F50.0614	AYPC.F50.0712	AYPC.F50.0913	FRK 14	AYPC.F50.0913	FRK 14	AYPC.F50.0948-03 AYPC.F50.0949-03 2x8c5,5x45 DIN 7981	100x56	x1	x2	x3	x70/x70
	157,5°-172,5°	AYPC.F50.0614-01	AYPC.F50.0712	AYPC.F50.0913	FRK 15	AYPC.F50.0913	FRK 15		100x56	x1	x2	x3	
50	157,5°-172,5°	AYPC.F50.0614	AYPC.F50.0712	AYPC.F50.0913	FRK 14	AYPC.F50.0913	FRK 14	AYPC.F50.0948-03 AYPC.F50.0949-03 2x8c5,5x45 DIN 7981	100x56	x1	x2	x3	x70/x70
	157,5°-172,5°	AYPC.F50.0614-01	AYPC.F50.0712	AYPC.F50.0913	FRK 15	AYPC.F50.0913	FRK 15		100x56	x1	x2	x3	
52	157,5°-172,5°	AYPC.F50.0614	AYPC.F50.0712	AYPC.F50.0914	FRK 16	AYPC.F50.0914	FRK 16	AYPC.F50.0953 AYPC.F50.0952-03	100x62	x1	x2	x3	x80/x80
	157,5°-172,5°	AYPC.F50.0614-01	AYPC.F50.0712	AYPC.F50.0914	FRK 15	AYPC.F50.0914	FRK 15		100x62	x1	x2	x3	
54	157,5°-172,5°	AYPC.F50.0614	AYPC.F50.0712	AYPC.F50.0914	FRK 14	AYPC.F50.0914	FRK 14	AYPC.F50.0953 AYPC.F50.0952-03	100x62	x1	x2	x3	x80/x80
	157,5°-172,5°	AYPC.F50.0614-01	AYPC.F50.0712	AYPC.F50.0914	FRK 15	AYPC.F50.0914	FRK 15		100x62	x1	x2	x3	
56	157,5°-172,5°	AYPC.F50.0614	AYPC.F50.0712	AYPC.F50.0914	FRK 14	AYPC.F50.0914	FRK 14	AYPC.F50.0953 AYPC.F50.0952-03	100x62	x1	x2	x3	x80/x80
58	157,5°-172,5°	AYPC.F50.0614-01	AYPC.F50.0712	AYPC.F50.0914	FRK 16	AYPC.F50.0914	FRK 16	AYPC.F50.0953 AYPC.F50.0952-03	100x62	x1	x2	x3	x80/x80
60	157,5°-172,5°	AYPC.F50.0614-01	AYPC.F50.0712	AYPC.F50.0914	FRK 15	AYPC.F50.0914	FRK 15	AYPC.F50.0953 AYPC.F50.0952-03	100x62	x1	x2	x3	x80/x80
62	157,5°-172,5°	AYPC.F50.0614-01	AYPC.F50.0712	AYPC.F50.0914	FRK 14	AYPC.F50.0914	FRK 14	AYPC.F50.0953 AYPC.F50.0952-03	100x62	x1	x2	x3	x80/x80

Curtain wall glazing for exterior reversible angles depending on the type of profiles integrated

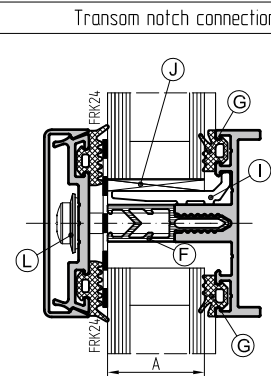
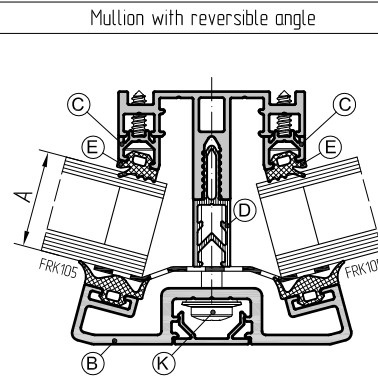
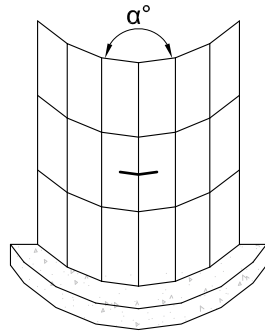

Glass thickness	Angle of turn	Clamping bar	Corner adapter +15°	Thermal break on the mullion	Gasket on the mullion	Thermal break on the transom	Gasket on the transom	Glass support			Self-tapping screw 5,5 DIN 7981		
								bearing	levelling				
A	$\alpha$	B	C	D	E	F	G	I	J	K/L			
22	150°-157,5°	AYPC.F50.0605	AYPC.F50.0705	AYPC.F50.0905 AYPC.F50.0908	FRK 16	AYPC.F50.0905 AYPC.F50.0908	FRK 16	AYPC.F50.0941	100x26	x1	x2	x3	x38/38
	142,5°-150°	AYPC.F50.0605-01	AYPC.F50.0705										
24	150°-157,5°	AYPC.F50.0605	AYPC.F50.0705	AYPC.F50.0905 AYPC.F50.0908	FRK 15	AYPC.F50.0905 AYPC.F50.0908	FRK 15	AYPC.F50.0941	100x26	x1	x2	x3	x38/38
	142,5°-150°	AYPC.F50.0605-01	AYPC.F50.0705										
26	150°-157,5°	AYPC.F50.0605	AYPC.F50.0705	AYPC.F50.0905 AYPC.F50.0908	FRK 14	AYPC.F50.0905 AYPC.F50.0908	FRK 14	AYPC.F50.0941	100x26	x1	x2	x3	x38/38
	142,5°-150°	AYPC.F50.0605-01	AYPC.F50.0705										
28	150°-157,5°	AYPC.F50.0605	AYPC.F50.0705	AYPC.F50.0906 AYPC.F50.0909	FRK 16	AYPC.F50.0906 AYPC.F50.0909	FRK 16	AYPC.F50.0941-01	100x32	x1	x2	x3	x45/45
	142,5°-150°	AYPC.F50.0605-01	AYPC.F50.0705										
30	150°-157,5°	AYPC.F50.0605	AYPC.F50.0705	AYPC.F50.0906 AYPC.F50.0909	FRK 15	AYPC.F50.0906 AYPC.F50.0909	FRK 15	AYPC.F50.0941-01	100x32	x1	x2	x3	x45/45
	142,5°-150°	AYPC.F50.0605-01	AYPC.F50.0705										
32	150°-157,5°	AYPC.F50.0605	AYPC.F50.0705	AYPC.F50.0906 AYPC.F50.0909	FRK 14	AYPC.F50.0906 AYPC.F50.0909	FRK 14	AYPC.F50.0941-01	100x32	x1	x2	x3	x45/45
	142,5°-150°	AYPC.F50.0605-01	AYPC.F50.0705										
34	150°-157,5°	AYPC.F50.0605-01	AYPC.F50.0705	AYPC.F50.0907 AYPC.F50.0910	FRK 16	AYPC.F50.0907 AYPC.F50.0910	FRK 16	AYPC.F50.0941-02	100x38	x1	x2	x3	x55/55
36	142,5°-150°	AYPC.F50.0605-01	AYPC.F50.0705	AYPC.F50.0907 AYPC.F50.0910	FRK 15	AYPC.F50.0907 AYPC.F50.0910	FRK 15	AYPC.F50.0941-02	100x38	x1	x2	x3	x55/55
38	150°-157,5°	AYPC.F50.0605-01	AYPC.F50.0705	AYPC.F50.0907 AYPC.F50.0910	FRK 14	AYPC.F50.0907 AYPC.F50.0910	FRK 14	AYPC.F50.0941-02	100x38	x1	x2	x3	x55/55
40	142,5°-150°	AYPC.F50.0605-01	AYPC.F50.0705	AYPC.F50.0915 AYPC.F50.0911	FRK 16	AYPC.F50.0915 AYPC.F50.0911	FRK 16	AYPC.F50.0948-01 AYPC.F50.0949-01 2x6c5,5x35 ISO 4762	100x44	x1	x2	x3	x60/x60
42	150°-157,5°	AYPC.F50.0605-01	AYPC.F50.0705	AYPC.F50.0915 AYPC.F50.0911	FRK 15	AYPC.F50.0915 AYPC.F50.0911	FRK 15		100x44	x1	x2	x3	x60/x60
44	142,5°-150°	AYPC.F50.0605-01	AYPC.F50.0705	AYPC.F50.0915 AYPC.F50.0911	FRK 14	AYPC.F50.0915 AYPC.F50.0911	FRK 14	100x44	x1	x2	x3	x60/x60	
46	150°-157,5°	AYPC.F50.0605-01	AYPC.F50.0705	AYPC.F50.0916 AYPC.F50.0912	FRK 16	AYPC.F50.0916 AYPC.F50.0912	FRK 16	AYPC.F50.0948-02 AYPC.F50.0949-02 2x6c5,5x38 DIN 7981	100x50	x1	x2	x3	x65/x65
48	142,5°-150°	AYPC.F50.0605-01	AYPC.F50.0705	AYPC.F50.0916 AYPC.F50.0912	FRK 15	AYPC.F50.0916 AYPC.F50.0912	FRK 15		100x50	x1	x2	x3	x65/x65
50	142,5°-150°	AYPC.F50.0605-01	AYPC.F50.0705	AYPC.F50.0916 AYPC.F50.0912	FRK 14	AYPC.F50.0916 AYPC.F50.0912	FRK 14	100x50	x1	x2	x3	x65/x65	
52	150°-157,5°	AYPC.F50.0605-01	AYPC.F50.0705	AYPC.F50.0913	FRK 16	AYPC.F50.0913	FRK 16	AYPC.F50.0948-03 AYPC.F50.0949-03 2x6c5,5x45 DIN 7981	100x56	x1	x2	x3	x70/x70
54	142,5°-150°	AYPC.F50.0605-01	AYPC.F50.0705	AYPC.F50.0913	FRK 15	AYPC.F50.0913	FRK 15		100x56	x1	x2	x3	x70/x70
56	150°-157,5°	AYPC.F50.0605-01	AYPC.F50.0705	AYPC.F50.0913	FRK 14	AYPC.F50.0913	FRK 14	100x56	x1	x2	x3	x70/x70	
58	142,5°-150°	AYPC.F50.0605-01	AYPC.F50.0705	AYPC.F50.0914	FRK 16	AYPC.F50.0914	FRK 16	AYPC.F50.0953 AYPC.F50.0952-03	100x62	x1	x2	x3	x80/x80
60	150°-157,5°	AYPC.F50.0605-01	AYPC.F50.0705	AYPC.F50.0914	FRK 15	AYPC.F50.0914	FRK 15		100x62	x1	x2	x3	x80/x80
62	142,5°-150°	AYPC.F50.0605-01	AYPC.F50.0705	AYPC.F50.0914	FRK 14	AYPC.F50.0914	FRK 14	100x62	x1	x2	x3	x80/x80	



Curtain wall glazing for exterior reversible angles depending on the type of profiles integrated

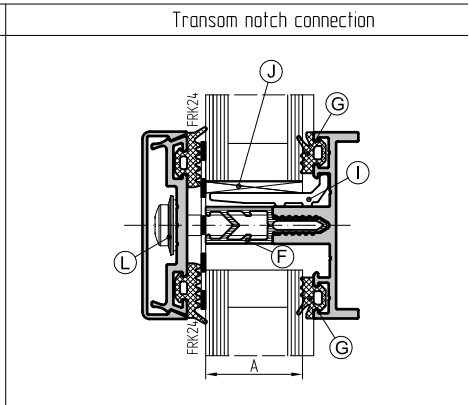
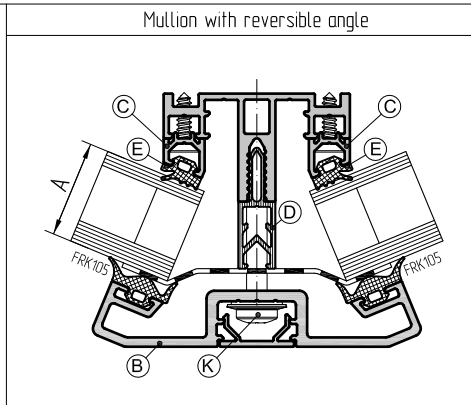
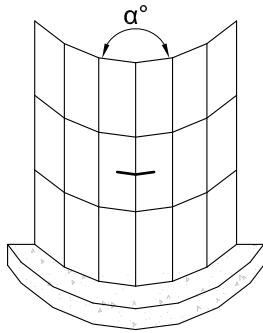

Glass thickness	Angle of turn	Clamping bar	Corner adapter +22,5°	Thermal break on the mullion	Gasket on the mullion	Thermal break on the transom	Gasket on the transom	Glass support				Self-tapping screw 5,5 DIN 7981	
								bearing		levelling			
A	α°	B	C	D	E	F	G	I	J			K/L	
22	127,5°-142,5°	AYPC.F50.0615	AYPC.F50.0713	AYPC.F50.0905 AYPC.F50.0908	FRK 16	AYPC.F50.0905 AYPC.F50.0908	FRK 16	AYPC.F50.0941	100x26	x1	x2	x3	x38/38
24	127,5°-142,5°	AYPC.F50.0615	AYPC.F50.0713	AYPC.F50.0905 AYPC.F50.0908	FRK 15	AYPC.F50.0905 AYPC.F50.0908	FRK 15	AYPC.F50.0941	100x26	x1	x2	x3	x38/38
26	127,5°-142,5°	AYPC.F50.0615	AYPC.F50.0713	AYPC.F50.0905 AYPC.F50.0908	FRK 14	AYPC.F50.0905 AYPC.F50.0908	FRK 14	AYPC.F50.0941	100x26	x1	x2	x3	x38/38
28	127,5°-142,5°	AYPC.F50.0615	AYPC.F50.0713	AYPC.F50.0906 AYPC.F50.0909	FRK 16	AYPC.F50.0906 AYPC.F50.0909	FRK 16	AYPC.F50.0941-01	100x32	x1	x2	x3	x45/45
30	127,5°-142,5°	AYPC.F50.0615	AYPC.F50.0713	AYPC.F50.0906 AYPC.F50.0909	FRK 15	AYPC.F50.0906 AYPC.F50.0909	FRK 15	AYPC.F50.0941-01	100x32	x1	x2	x3	x45/45
32	127,5°-142,5°	AYPC.F50.0615	AYPC.F50.0713	AYPC.F50.0906 AYPC.F50.0909	FRK 14	AYPC.F50.0906 AYPC.F50.0909	FRK 14	AYPC.F50.0941-01	100x32	x1	x2	x3	x45/45
34	139°-142,5°	AYPC.F50.0615	AYPC.F50.0713	AYPC.F50.0907 AYPC.F50.0910	FRK 16	AYPC.F50.0907 AYPC.F50.0910	FRK 16	AYPC.F50.0941-02	100x38	x1	x2	x3	x55/55
		127,5°-139°	AYPC.F50.0615-01										
36	139°-142,5°	AYPC.F50.0615	AYPC.F50.0713	AYPC.F50.0907 AYPC.F50.0910	FRK 15	AYPC.F50.0907 AYPC.F50.0910	FRK 15	AYPC.F50.0941-02	100x38	x1	x2	x3	x55/55
		127,5°-139°	AYPC.F50.0615-01										
38	139°-142,5°	AYPC.F50.0615	AYPC.F50.0713	AYPC.F50.0907 AYPC.F50.0910	FRK 14	AYPC.F50.0907 AYPC.F50.0910	FRK 14	AYPC.F50.0941-02	100x38	x1	x2	x3	x55/55
		127,5°-139°	AYPC.F50.0615-01										
40	127,5°-142,5°	AYPC.F50.0615-01	AYPC.F50.0713	AYPC.F50.0915 AYPC.F50.0911	FRK 16	AYPC.F50.0915 AYPC.F50.0911	FRK 16	AYPC.F50.0948-01 AYPC.F50.0949-01	100x44	x1	x2	x3	x60/x60
42	127,5°-142,5°	AYPC.F50.0615-01	AYPC.F50.0713	AYPC.F50.0915 AYPC.F50.0911	FRK 15	AYPC.F50.0915 AYPC.F50.0911	FRK 15		2x6c5,5x35 ISO 4762	100x44	x1	x2	x3
44	127,5°-142,5°	AYPC.F50.0615-01	AYPC.F50.0713	AYPC.F50.0915 AYPC.F50.0911	FRK 14	AYPC.F50.0915 AYPC.F50.0911	FRK 14	AYPC.F50.0948-02 AYPC.F50.0949-02	100x44	x1	x2	x3	x60/x60
46	127,5°-142,5°	AYPC.F50.0615-01	AYPC.F50.0713	AYPC.F50.0916 AYPC.F50.0912	FRK 16	AYPC.F50.0916 AYPC.F50.0912	FRK 16		2x6c5,5x38 DIN 7981	100x50	x1	x2	x3
48	127,5°-142,5°	AYPC.F50.0615-01	AYPC.F50.0713	AYPC.F50.0916 AYPC.F50.0912	FRK 15	AYPC.F50.0916 AYPC.F50.0912	FRK 15	AYPC.F50.0948-03 AYPC.F50.0949-03	100x50	x1	x2	x3	x65/x65
50	127,5°-142,5°	AYPC.F50.0615-01	AYPC.F50.0713	AYPC.F50.0916 AYPC.F50.0912	FRK 14	AYPC.F50.0916 AYPC.F50.0912	FRK 14		2x6c5,5x45 DIN 7981	100x50	x1	x2	x3
52	127,5°-142,5°	AYPC.F50.0615-01	AYPC.F50.0713	AYPC.F50.0913	FRK 16	AYPC.F50.0913	FRK 16	AYPC.F50.0948-03 AYPC.F50.0949-03	100x56	x1	x2	x3	x70/x70
54	127,5°-142,5°	AYPC.F50.0615-01	AYPC.F50.0713	AYPC.F50.0913	FRK 15	AYPC.F50.0913	FRK 15		2x6c5,5x45 DIN 7981	100x56	x1	x2	x3
56	127,5°-142,5°	AYPC.F50.0615-01	AYPC.F50.0713	AYPC.F50.0913	FRK 14	AYPC.F50.0913	FRK 14	AYPC.F50.0953 AYPC.F50.0952-03	100x62	x1	x2	x3	x80/x80
58	127,5°-142,5°	AYPC.F50.0615-01	AYPC.F50.0713	AYPC.F50.0914	FRK 16	AYPC.F50.0914	FRK 16		2x6c5,5x45 DIN 7981	100x62	x1	x2	x3
60	127,5°-142,5°	AYPC.F50.0615-01	AYPC.F50.0713	AYPC.F50.0914	FRK 15	AYPC.F50.0914	FRK 15	AYPC.F50.0953 AYPC.F50.0952-03	100x62	x1	x2	x3	x80/x80
62	127,5°-142,5°	AYPC.F50.0615-01	AYPC.F50.0713	AYPC.F50.0914	FRK 14	AYPC.F50.0914	FRK 14		2x6c5,5x45 DIN 7981	100x62	x1	x2	x3

Curtain wall glazing for exterior reversible angles depending on type of profiles integrated

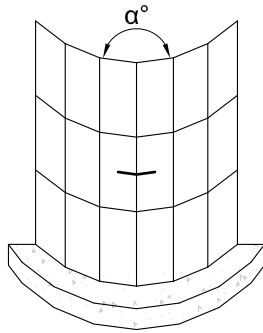

Mullion with reversible angle of return

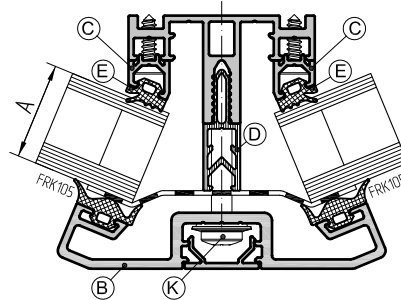

Transom notch connection

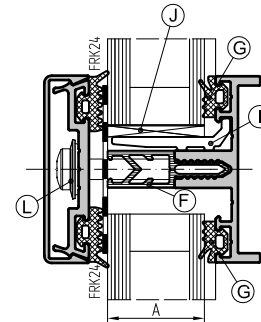

Glass thickness	Angle of return	Clamping bar	Corner adapter +30°	Thermal break on the mullion	Gasket on the mullion	Thermal break on the transom	Gasket on the transom-bar	Support for glass unit			Self-tapping screw 5,5 DIN 7981		
								bearing	levelling				
A	$\alpha^\circ$	B	C	D	E	F	G	I	J		K/L		
22	112,5°-127,5°	AYPC.F50.0606	AYPC.F50.0706	AYPC.F50.0905 AYPC.F50.0908	FRK 16	AYPC.F50.0905 AYPC.F50.0908	FRK 16	AYPC.F50.0941	100x26	x1	x2	x3	x38/38
24	112,5°-127,5°	AYPC.F50.0606	AYPC.F50.0706	AYPC.F50.0905 AYPC.F50.0908	FRK 15	AYPC.F50.0905 AYPC.F50.0908	FRK 15	AYPC.F50.0941	100x26	x1	x2	x3	x38/38
26	112,5°-127,5°	AYPC.F50.0606	AYPC.F50.0706	AYPC.F50.0905 AYPC.F50.0908	FRK 14	AYPC.F50.0905 AYPC.F50.0908	FRK 14	AYPC.F50.0941	100x26	x1	x2	x3	x38/38
28	112,5°-127,5°	AYPC.F50.0606	AYPC.F50.0706	AYPC.F50.0906 AYPC.F50.0909	FRK 16	AYPC.F50.0906 AYPC.F50.0909	FRK 16	AYPC.F50.0941-01	100x32	x1	x2	x3	x45/45
30	112,5°-127,5°	AYPC.F50.0606	AYPC.F50.0706	AYPC.F50.0906 AYPC.F50.0909	FRK 15	AYPC.F50.0906 AYPC.F50.0909	FRK 15	AYPC.F50.0941-01	100x32	x1	x2	x3	x45/45
32	112,5°-127,5°	AYPC.F50.0606	AYPC.F50.0706	AYPC.F50.0906 AYPC.F50.0909	FRK 14	AYPC.F50.0906 AYPC.F50.0909	FRK 14	AYPC.F50.0941-01	100x32	x1	x2	x3	x45/45
34	120°-127,5°	AYPC.F50.0606	AYPC.F50.0706	AYPC.F50.0907 AYPC.F50.0910	FRK 16	AYPC.F50.0907 AYPC.F50.0910	FRK 16	AYPC.F50.0941-02	100x38	x1	x2	x3	x55/55
	112,5°-120°	AYPC.F50.0606-01	AYPC.F50.0706										x50/55
36	120°-127,5°	AYPC.F50.0606	AYPC.F50.0706	AYPC.F50.0907 AYPC.F50.0910	FRK 15	AYPC.F50.0907 AYPC.F50.0910	FRK 15	AYPC.F50.0941-02	100x38	x1	x2	x3	x55/55
	112,5°-120°	AYPC.F50.0606-01	AYPC.F50.0706										x50/55
38	120°-127,5°	AYPC.F50.0606	AYPC.F50.0706	AYPC.F50.0907 AYPC.F50.0910	FRK 14	AYPC.F50.0907 AYPC.F50.0910	FRK 14	AYPC.F50.0941-02	100x38	x1	x2	x3	x55/55
	112,5°-120°	AYPC.F50.0606-01	AYPC.F50.0706										x50/55
40	112,5°-127,5°	AYPC.F50.0606-01	AYPC.F50.0706	AYPC.F50.0915 AYPC.F50.0911	FRK 16	AYPC.F50.0915 AYPC.F50.0911	FRK 16	AYPC.F50.0948-01 AYPC.F50.0949-01 2x6c5,5x35 ISO 4762	100x44	x1	x2	x3	x60/x60
42	112,5°-127,5°	AYPC.F50.0606-01	AYPC.F50.0706	AYPC.F50.0915 AYPC.F50.0911	FRK 15	AYPC.F50.0915 AYPC.F50.0911	FRK 15		100x44	x1	x2	x3	x60/x60
44	112,5°-127,5°	AYPC.F50.0606-01	AYPC.F50.0706	AYPC.F50.0915 AYPC.F50.0911	FRK 14	AYPC.F50.0915 AYPC.F50.0911	FRK 14	AYPC.F50.0948-02 AYPC.F50.0949-02 2x6c5,5x38 DIN 7981	100x44	x1	x2	x3	x60/x60
46	112,5°-127,5°	AYPC.F50.0606-01	AYPC.F50.0706	AYPC.F50.0916 AYPC.F50.0912	FRK 16	AYPC.F50.0916 AYPC.F50.0912	FRK 16		100x50	x1	x2	x3	x65/x65
48	112,5°-127,5°	AYPC.F50.0606-01	AYPC.F50.0706	AYPC.F50.0916 AYPC.F50.0912	FRK 15	AYPC.F50.0916 AYPC.F50.0912	FRK 15	AYPC.F50.0948-03 AYPC.F50.0949-03 2x6c5,5x45 DIN 7981	100x50	x1	x2	x3	x65/x65
50	112,5°-127,5°	AYPC.F50.0606-01	AYPC.F50.0706	AYPC.F50.0916 AYPC.F50.0912	FRK 14	AYPC.F50.0916 AYPC.F50.0912	FRK 14		100x50	x1	x2	x3	x65/x65
52	112,5°-127,5°	AYPC.F50.0606-01	AYPC.F50.0706	AYPC.F50.0913	FRK 16	AYPC.F50.0913	FRK 16	AYPC.F50.0948-03 AYPC.F50.0949-03 2x6c5,5x45 DIN 7981	100x56	x1	x2	x3	x70/x70
54	112,5°-127,5°	AYPC.F50.0606-01	AYPC.F50.0706	AYPC.F50.0913	FRK 15	AYPC.F50.0913	FRK 15		100x56	x1	x2	x3	x70/x70
56	112,5°-127,5°	AYPC.F50.0606-01	AYPC.F50.0706	AYPC.F50.0913	FRK 14	AYPC.F50.0913	FRK 14	AYPC.F50.0953 AYPC.F50.0952-03	100x56	x1	x2	x3	x70/x70
58	112,5°-127,5°	AYPC.F50.0606-01	AYPC.F50.0706	AYPC.F50.0914	FRK 16	AYPC.F50.0914	FRK 16		100x62	x1	x2	x3	x80/x80
60	112,5°-127,5°	AYPC.F50.0606-01	AYPC.F50.0706	AYPC.F50.0914	FRK 15	AYPC.F50.0914	FRK 15	AYPC.F50.0953 AYPC.F50.0952-03	100x62	x1	x2	x3	x80/x80
62	112,5°-127,5°	AYPC.F50.0606-01	AYPC.F50.0706	AYPC.F50.0914	FRK 14	AYPC.F50.0914	FRK 14		100x62	x1	x2	x3	x80/x80

Curtain wall glazing for exterior reversible angles depending on type of profiles integrated

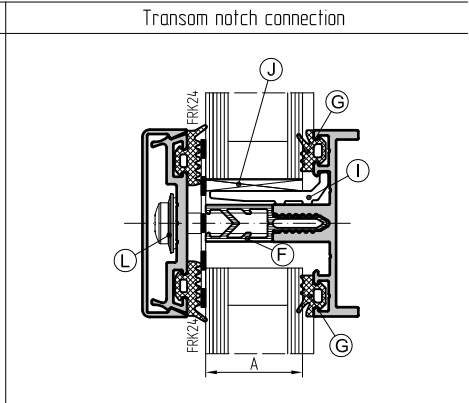
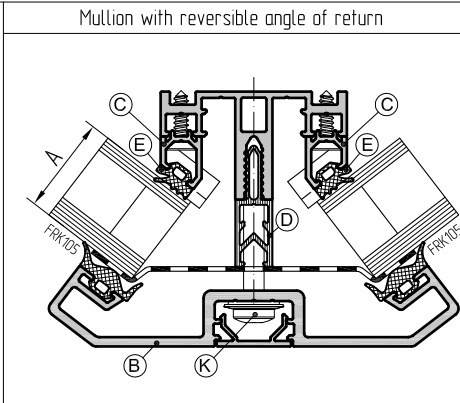
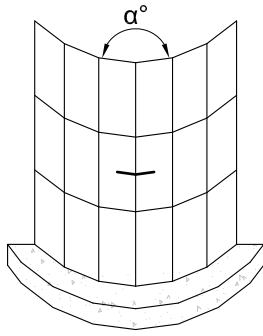

Glass thickness	Angle of turn	Clamping bar	Corner adapter +37,5°	Thermal break on the mullion	Gasket on the mullion	Thermal break on the transom	Gasket on the transom-bar	Support for glass unit				Self-tapping screw 5,5 DIN 7981	
								bearing		levelling			
A	α°	B	C	D	E	F	G	I	J			K/L	
22	97,5°-112,5°	AYPC.F50.0616	AYPC.F50.0714	AYPC.F50.0905 AYPC.F50.0908	FRK 16	AYPC.F50.0905 AYPC.F50.0908	FRK 16	AYPC.F50.0941	100x26	x1	x2	x3	x38/38
24	97,5°-112,5°	AYPC.F50.0616	AYPC.F50.0714	AYPC.F50.0905 AYPC.F50.0908	FRK 15	AYPC.F50.0905 AYPC.F50.0908	FRK 15	AYPC.F50.0941	100x26	x1	x2	x3	x38/38
26	97,5°-112,5°	AYPC.F50.0616	AYPC.F50.0714	AYPC.F50.0905 AYPC.F50.0908	FRK 14	AYPC.F50.0905 AYPC.F50.0908	FRK 14	AYPC.F50.0941	100x26	x1	x2	x3	x38/38
28	97,5°-112,5°	AYPC.F50.0616	AYPC.F50.0714	AYPC.F50.0906 AYPC.F50.0909	FRK 16	AYPC.F50.0906 AYPC.F50.0909	FRK 16	AYPC.F50.0941-01	100x32	x1	x2	x3	x45/45
30	97,5°-112,5°	AYPC.F50.0616	AYPC.F50.0714	AYPC.F50.0906 AYPC.F50.0909	FRK 15	AYPC.F50.0906 AYPC.F50.0909	FRK 15	AYPC.F50.0941-01	100x32	x1	x2	x3	x45/45
32	97,5°-112,5°	AYPC.F50.0616	AYPC.F50.0714	AYPC.F50.0906 AYPC.F50.0909	FRK 14	AYPC.F50.0906 AYPC.F50.0909	FRK 14	AYPC.F50.0941-01	100x32	x1	x2	x3	x45/45
34	97,5°-112,5°	AYPC.F50.0616-01	AYPC.F50.0714	AYPC.F50.0906 AYPC.F50.0909	FRK 16	AYPC.F50.0907 AYPC.F50.0910	FRK 16	AYPC.F50.0941-02	100x38	x1	x2	x3	x50/55
36	97,5°-112,5°	AYPC.F50.0616-01	AYPC.F50.0714	AYPC.F50.0906 AYPC.F50.0909	FRK 15	AYPC.F50.0907 AYPC.F50.0910	FRK 15	AYPC.F50.0941-02	100x38	x1	x2	x3	x50/55
38	97,5°-112,5°	AYPC.F50.0616-01	AYPC.F50.0714	AYPC.F50.0906 AYPC.F50.0909	FRK 14	AYPC.F50.0907 AYPC.F50.0910	FRK 14	AYPC.F50.0941-02	100x38	x1	x2	x3	x50/55
40	97,5°-112,5°	AYPC.F50.0616-01	AYPC.F50.0714	AYPC.F50.0907 AYPC.F50.0910	FRK 16	AYPC.F50.0915 AYPC.F50.0911	FRK 16	AYPC.F50.0948-01 AYPC.F50.0949-01	100x44	x1	x2	x3	x55/x60
42	97,5°-112,5°	AYPC.F50.0616-01	AYPC.F50.0714	AYPC.F50.0907 AYPC.F50.0910	FRK 15	AYPC.F50.0915 AYPC.F50.0911	FRK 15		2xhc5,5x35 ISO 4762	100x44	x1	x2	x3
44	97,5°-112,5°	AYPC.F50.0616-01	AYPC.F50.0714	AYPC.F50.0907 AYPC.F50.0910	FRK 14	AYPC.F50.0915 AYPC.F50.0911	FRK 14	AYPC.F50.0948-02 AYPC.F50.0949-02	100x44	x1	x2	x3	x55/x60
46	97,5°-112,5°	AYPC.F50.0616-01	AYPC.F50.0714	AYPC.F50.0916 AYPC.F50.0912	FRK 16	AYPC.F50.0916 AYPC.F50.0912	FRK 16		2xhc5,5x38 DIN 7981	100x50	x1	x2	x3
48	97,5°-112,5°	AYPC.F50.0616-01	AYPC.F50.0714	AYPC.F50.0916 AYPC.F50.0912	FRK 15	AYPC.F50.0916 AYPC.F50.0912	FRK 15	AYPC.F50.0948-03 AYPC.F50.0949-03	100x50	x1	x2	x3	x65/x65
50	97,5°-112,5°	AYPC.F50.0616-01	AYPC.F50.0714	AYPC.F50.0916 AYPC.F50.0912	FRK 14	AYPC.F50.0916 AYPC.F50.0912	FRK 14		2xhc5,5x45 DIN 7981	100x50	x1	x2	x3
52	97,5°-112,5°	AYPC.F50.0616-01	AYPC.F50.0714	AYPC.F50.0913	FRK 16	AYPC.F50.0913	FRK 16	AYPC.F50.0953 AYPC.F50.0952-03	100x56	x1	x2	x3	x70/x70
54	97,5°-112,5°	AYPC.F50.0616-01	AYPC.F50.0714	AYPC.F50.0913	FRK 15	AYPC.F50.0913	FRK 15		100x56	x1	x2	x3	x70/x70
56	97,5°-112,5°	AYPC.F50.0616-01	AYPC.F50.0714	AYPC.F50.0913	FRK 14	AYPC.F50.0913	FRK 14	100x56	x1	x2	x3	x70/x70	
58	97,5°-112,5°	AYPC.F50.0616-01	AYPC.F50.0714	AYPC.F50.0914	FRK 16	AYPC.F50.0914	FRK 16	100x62	x1	x2	x3	x80/x80	
60	97,5°-112,5°	AYPC.F50.0616-01	AYPC.F50.0714	AYPC.F50.0914	FRK 15	AYPC.F50.0914	FRK 15	100x62	x1	x2	x3	x80/x80	
62	97,5°-112,5°	AYPC.F50.0616-01	AYPC.F50.0714	AYPC.F50.0914	FRK 14	AYPC.F50.0914	FRK 14	100x62	x1	x2	x3	x80/x80	



Curtain wall glazing for exterior reversible angles depending on type of profiles integrated

Mullion with reversible angle of return

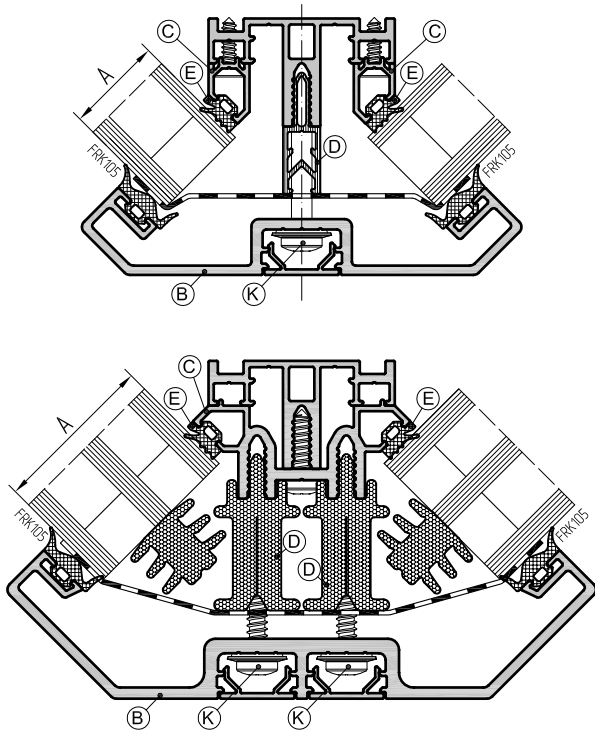

Transom notch connection

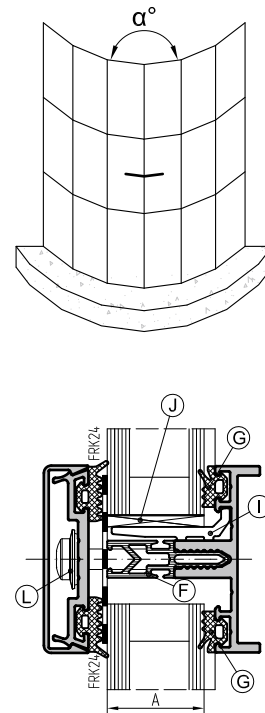

Glass thickness	Angle of turn	Clamping bar	Corner adapter +45°	Thermal break on the mullion	Gasket on the mullion	Thermal break on the transom	Gasket on the transom-bar	Support for glass unit			Self-tapping screw 5.5 DIN 7981		
								bearing	levelling				
A	$\alpha^\circ$	B	C	D	E	F	G	I	J	K/L			
22	90°-97,5°	AYPC.F50.0607	AYPC.F50.0707	AYPC.F50.0905 AYPC.F50.0908	FRK 16	AYPC.F50.0905 AYPC.F50.0905	FRK 16	AYPC.F50.0941	100x26	x1	x2	x3	x45/38
24	90°-97,5°	AYPC.F50.0607	AYPC.F50.0707	AYPC.F50.0905 AYPC.F50.0908	FRK 15	AYPC.F50.0905 AYPC.F50.0908	FRK 15	AYPC.F50.0941	100x26	x1	x2	x3	x45/38
26	90°-97,5°	AYPC.F50.0607	AYPC.F50.0707	AYPC.F50.0905 AYPC.F50.0908	FRK 14	AYPC.F50.0905 AYPC.F50.0908	FRK 14	AYPC.F50.0941	100x26	x1	x2	x3	x45/38
28	90°-97,5°	AYPC.F50.0607	AYPC.F50.0707	AYPC.F50.0906 AYPC.F50.0909	FRK 16	AYPC.F50.0906 AYPC.F50.0909	FRK 16	AYPC.F50.0941-01	100x32	x1	x2	x3	x50/45
30	90°-97,5°	AYPC.F50.0607	AYPC.F50.0707	AYPC.F50.0906 AYPC.F50.0909	FRK 15	AYPC.F50.0906 AYPC.F50.0909	FRK 15	AYPC.F50.0941-01	100x32	x1	x2	x3	x50/45
32	90°-97,5°	AYPC.F50.0607	AYPC.F50.0707	AYPC.F50.0906 AYPC.F50.0909	FRK 14	AYPC.F50.0906 AYPC.F50.0909	FRK 14	AYPC.F50.0941-01	100x32	x1	x2	x3	x50/45
34	90°-97,5°	AYPC.F50.0607-01	AYPC.F50.0715	AYPC.F50.0906 AYPC.F50.0909	FRK 16	AYPC.F50.0907 AYPC.F50.0910	FRK 16	AYPC.F50.0941-02	100x38	x1	x2	x3	x50/55
36	90°-97,5°	AYPC.F50.0607-01	AYPC.F50.0715	AYPC.F50.0906 AYPC.F50.0909	FRK 15	AYPC.F50.0907 AYPC.F50.0910	FRK 15	AYPC.F50.0941-02	100x38	x1	x2	x3	x50/55
38	90°-97,5°	AYPC.F50.0607-01	AYPC.F50.0715	AYPC.F50.0906 AYPC.F50.0909	FRK 14	AYPC.F50.0907 AYPC.F50.0910	FRK 14	AYPC.F50.0941-02	100x38	x1	x2	x3	x50/55
40	90°-97,5°	AYPC.F50.0607-01	AYPC.F50.0715	AYPC.F50.0907 AYPC.F50.0910	FRK 16	AYPC.F50.0915 AYPC.F50.0911	FRK 16	AYPC.F50.0948-01 AYPC.F50.0949-01 2xØc5,5x35 ISO 4762	100x44	x1	x2	x3	x55/x60
42	90°-97,5°	AYPC.F50.0607-01	AYPC.F50.0715	AYPC.F50.0907 AYPC.F50.0910	FRK 15	AYPC.F50.0915 AYPC.F50.0911	FRK 15		100x44	x1	x2	x3	x55/x60
44	90°-97,5°	AYPC.F50.0607-01	AYPC.F50.0715	AYPC.F50.0907 AYPC.F50.0910	FRK 14	AYPC.F50.0915 AYPC.F50.0911	FRK 14		100x44	x1	x2	x3	x55/x60
46	90°-97,5°	AYPC.F50.0607-01	AYPC.F50.0715	AYPC.F50.0915 AYPC.F50.0911	FRK 16	AYPC.F50.0916 AYPC.F50.0912	FRK 16	AYPC.F50.0948-02 AYPC.F50.0949-02 2xØc5,5x38 DIN 7981	100x50	x1	x2	x3	x65/x65
48	90°-97,5°	AYPC.F50.0607-01	AYPC.F50.0715	AYPC.F50.0915 AYPC.F50.0911	FRK 15	AYPC.F50.0916 AYPC.F50.0912	FRK 15		100x50	x1	x2	x3	x65/x65
50	90°-97,5°	AYPC.F50.0607-01	AYPC.F50.0715	AYPC.F50.0915 AYPC.F50.0911	FRK 14	AYPC.F50.0916 AYPC.F50.0912	FRK 14	AYPC.F50.0948-03 AYPC.F50.0949-03 2xØc5,5x45 DIN 7981	100x50	x1	x2	x3	x65/x65
52	90°-97,5°	AYPC.F50.0607-02	AYPC.F50.0715	AYPC.F50.0907 AYPC.F50.0910	FRK 16	AYPC.F50.0913	FRK 16		100x56	x1	x2	x3	x60/x70
54	90°-97,5°	AYPC.F50.0607-02	AYPC.F50.0715	AYPC.F50.0907 AYPC.F50.0910	FRK 15	AYPC.F50.0913	FRK 15		100x56	x1	x2	x3	x60/x70
56	90°-97,5°	AYPC.F50.0607-02	AYPC.F50.0715	AYPC.F50.0907 AYPC.F50.0910	FRK 14	AYPC.F50.0913	FRK 14	AYPC.F50.0953 AYPC.F50.0952-03	100x56	x1	x2	x3	x60/x70
58	90°-97,5°	AYPC.F50.0607-02	AYPC.F50.0715	AYPC.F50.0915 AYPC.F50.0911	FRK 16	AYPC.F50.0914	FRK 16		100x62	x1	x2	x3	x70/x80
60	90°-97,5°	AYPC.F50.0607-02	AYPC.F50.0715	AYPC.F50.0915 AYPC.F50.0911	FRK 15	AYPC.F50.0914	FRK 15		100x62	x1	x2	x3	x70/x80
62	90°-97,5°	AYPC.F50.0607-02	AYPC.F50.0715	AYPC.F50.0915 AYPC.F50.0911	FRK 14	AYPC.F50.0914	FRK 14	100x62	x1	x2	x3	x70/x80	

Curtain wall glazing for exterior reversible angles depending on type of profiles integrated

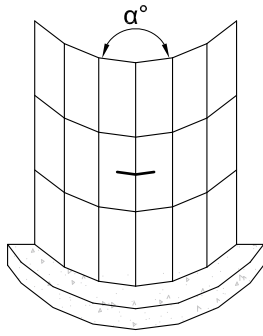

Mullion with reversible angle of return

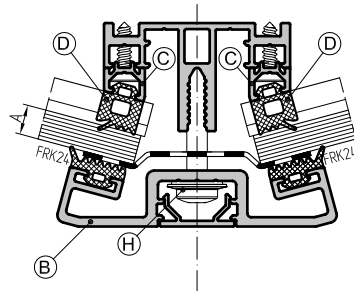

Transom notch connection

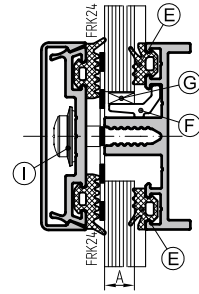

Glass thickness	Angle of return	Clamping bar	Corner adapter	Gasket on the mullion	Gasket on the transom-bar notch connection	Support for glass unit		Self-tapping screw Ø 5,5 DIN 7981		
						bearing	levelling			
A	$\alpha^\circ$	B	C	D	E	F	G	H/I		
4 mm	127,5°-1805°	AYPC.F50.6009	-	FRK19	FRK16	AYPC.F50.0940	FRK13	1 mm	x25/x22	
5mm/6 mm	127,5°-1805°	AYPC.F50.6009	-	FRK18	FRK15	AYPC.F50.0940	FRK13	1 mm	x25/x22	
8 mm	127,5°-1805°	AYPC.F50.6009	-	FRK17	FRK14	AYPC.F50.0940	FRK13	1 mm	x25/x22	
4 mm	157,5°-172,5°	AYPC.F50.0614	AYPC.F50.0712	+7,5°	FRK19	FRK16	AYPC.F50.0940	FRK13	1 mm	x25/x22
5mm/6 mm	157,5°-172,5°	AYPC.F50.0614	AYPC.F50.0712	+7,5°	FRK18	FRK15	AYPC.F50.0940	FRK13	1 mm	x25/x22
8 mm	157,5°-172,5°	AYPC.F50.0614	AYPC.F50.0712	+7,5°	FRK17	FRK14	AYPC.F50.0940	FRK13	1 mm	x25/x22
4 mm	142,5°-157,5°	AYPC.F50.0605	AYPC.F50.0705	+15°	FRK19	FRK16	AYPC.F50.0940	FRK13	1 mm	x25/x22
5mm/6 mm	142,5°-157,5°	AYPC.F50.0605	AYPC.F50.0705	+15°	FRK18	FRK15	AYPC.F50.0940	FRK13	1 mm	x25/x22
8 mm	142,5°-157,5°	AYPC.F50.0605	AYPC.F50.0705	+15°	FRK17	FRK14	AYPC.F50.0940	FRK13	1 mm	x25/x22
4 mm	127,5°-142,5°	AYPC.F50.0615	AYPC.F50.0713	+22,5°	FRK19	FRK16	AYPC.F50.0940	FRK13	1 mm	x25/x22
5mm/6 mm	127,5°-142,5°	AYPC.F50.0615	AYPC.F50.0713	+22,5°	FRK18	FRK15	AYPC.F50.0940	FRK13	1 mm	x25/x22
8 mm	127,5°-142,5°	AYPC.F50.0615	AYPC.F50.0713	+22,5°	FRK17	FRK14	AYPC.F50.0940	FRK13	1 mm	x25/x22
4 mm	112,5°-127,5°	AYPC.F50.0606	AYPC.F50.0706	+30°	FRK19	FRK16	AYPC.F50.0940	FRK13	1 mm	x25/x22
5mm/6 mm	112,5°-127,5°	AYPC.F50.0606	AYPC.F50.0706	+30°	FRK18	FRK15	AYPC.F50.0940	FRK13	1 mm	x25/x22
8 mm	112,5°-127,5°	AYPC.F50.0606	AYPC.F50.0706	+30°	FRK17	FRK14	AYPC.F50.0940	FRK13	1 mm	x25/x22
4 mm	97,5°-112,5°	AYPC.F50.0616	AYPC.F50.0714	+37,5°	FRK19	FRK16	AYPC.F50.0940	FRK13	1 mm	x25/x22
5mm/6 mm	97,5°-112,5°	AYPC.F50.0616	AYPC.F50.0714	+37,5°	FRK18	FRK15	AYPC.F50.0940	FRK13	1 mm	x25/x22
8 mm	97,5°-112,5°	AYPC.F50.0616	AYPC.F50.0714	+37,5°	FRK17	FRK14	AYPC.F50.0940	FRK13	1 mm	x25/x22
4 mm	90°-97,5°	AYPC.F50.0607	AYPC.F50.0707	+45°	FRK19	FRK16	AYPC.F50.0940	FRK13	1 mm	x25/x22
5mm/6 mm	90°-97,5°	AYPC.F50.0607	AYPC.F50.0707	+45°	FRK18	FRK15	AYPC.F50.0940	FRK13	1 mm	x25/x22
8 mm	90°-97,5°	AYPC.F50.0607	AYPC.F50.0707	+45°	FRK17	FRK14	AYPC.F50.0940	FRK13	1 mm	x25/x22

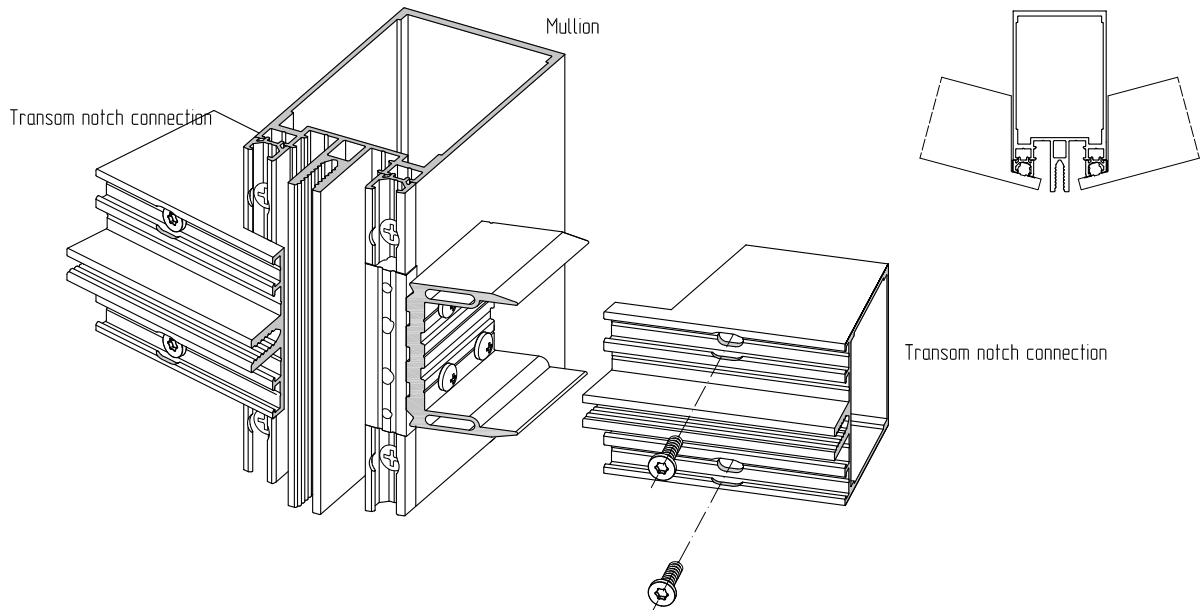

Installation of window unit with W72.0108 frame to translucent curtain wall construction

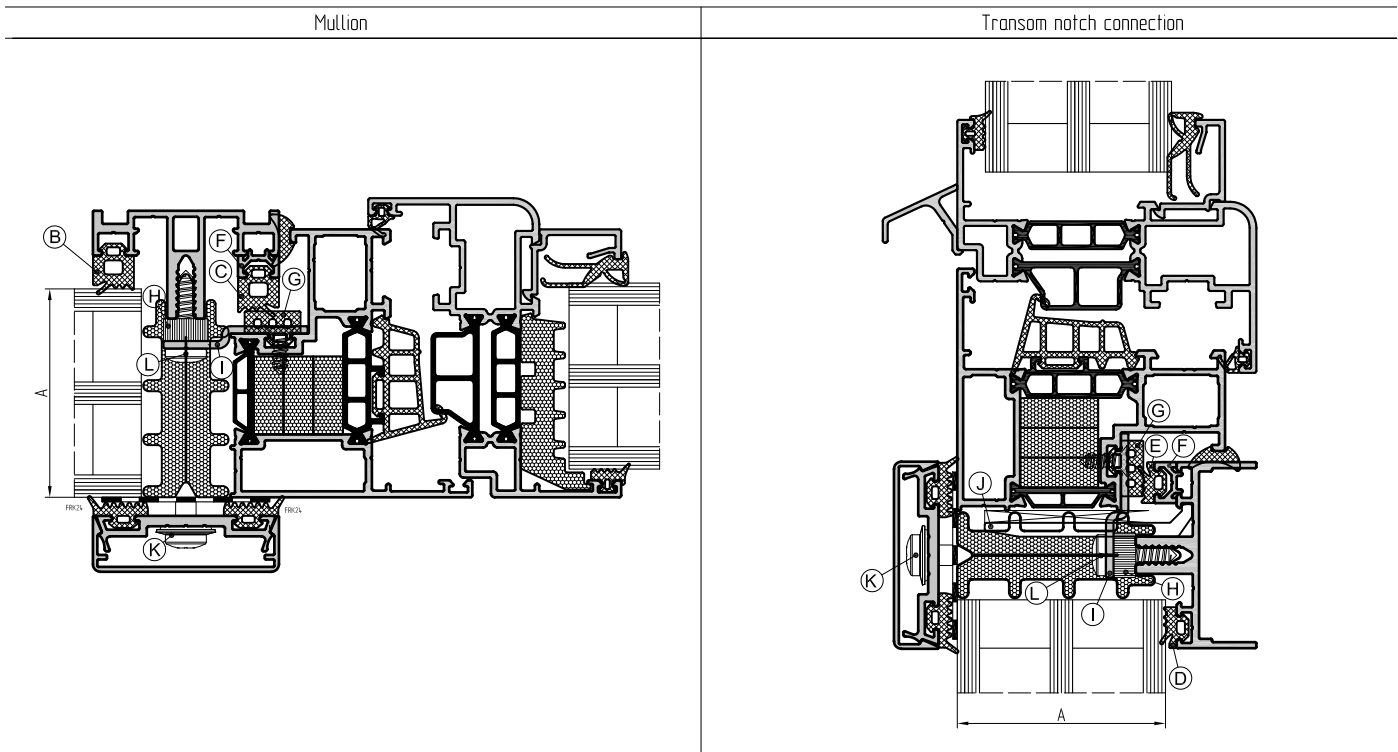

Glass thickness	Gasket on the mullion	Gasket on the mullion	Gasket on the transom bar	Gasket on the transom bar	Distance adapter	Gasket on the frame	Support for clamp	Clamp	Bearing support	Self-tapping screw $\varnothing$ 5,5 DIN 7981	
	A	B	C	D		E				F	G
40 mm	FRK19	FRK17	FRK16	FRK14	-	-	-	-	AYPC.F50.0941-02	x60	-
42 mm	FRK18	FRK17	FRK15	FRK14	-	-	-	-	AYPC.F50.0941-02	x60	-
44 mm	FRK17	FRK17	FRK14	FRK14	-	-	-	-	AYPC.F50.0941-02	x60	-
46 mm	FRK19	FRK19	FRK16	FRK16	-	FRK129	-	AYPC.W72.0951	AYPC.F50.0952	x65	x16
48 mm	FRK18	FRK18	FRK15	FRK15	-	FRK128	-	AYPC.W72.0951	AYPC.F50.0952	x65	x16
50 mm	FRK17	FRK17	FRK14	FRK14	-	FRK127	-	AYPC.W72.0951	AYPC.F50.0952	x65	x16
52 mm	FRK19	FRK19	FRK16	FRK16	AYPC.F50.0701	FRK129	1 x AYPC.F50.1945	AYPC.W72.0951	AYPC.F50.0952-01	x75	x22
54 mm	FRK18	FRK18	FRK15	FRK15	AYPC.F50.0701	FRK128	1 x AYPC.F50.1945	AYPC.W72.0951	AYPC.F50.0952-01	x75	x22
56 mm	FRK17	FRK17	FRK14	FRK14	AYPC.F50.0701	FRK127	1 x AYPC.F50.1945	AYPC.W72.0951	AYPC.F50.0952-01	x75	x22
58 mm	FRK19	FRK19	FRK16	FRK16	AYPC.F50.0702	FRK129	2 x AYPC.F50.1945	AYPC.W72.0951	AYPC.F50.0952-02	x80	x25
60 mm	FRK18	FRK18	FRK15	FRK15	AYPC.F50.0702	FRK128	2 x AYPC.F50.1945	AYPC.W72.0951	AYPC.F50.0952-02	x80	x25
62 mm	FRK17	FRK17	FRK14	FRK14	AYPC.F50.0702	FRK127	2 x AYPC.F50.1945	AYPC.W72.0951	AYPC.F50.0952-02	x80	x25

Window fixation to mullion-transom case with the width of 40-44 mm is made with help of self-tapping 4,2x13 DIN 7981 from the hardware groove.

01  
02  
03  
04  
05  
06  
07  
08  
09  
10  
11  
12  
13

Installation of window unit with W72.0108 frame to curtain wall construction

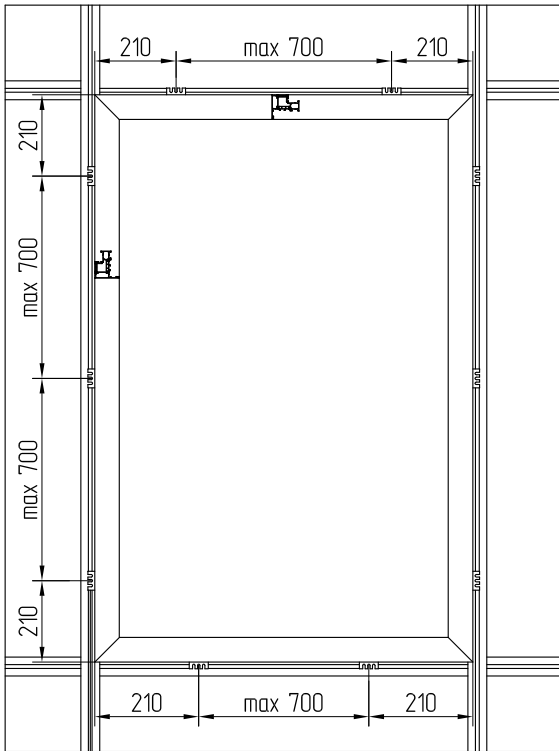

Processing of AYPC.W72.0108 for mounting of AYPC.W72.0951 clamp

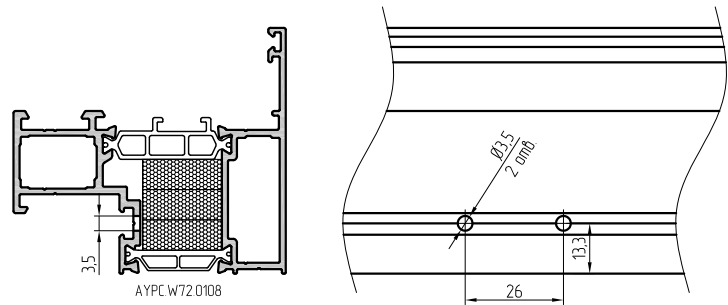

Mounting of AYPC.W72.0951 clamp

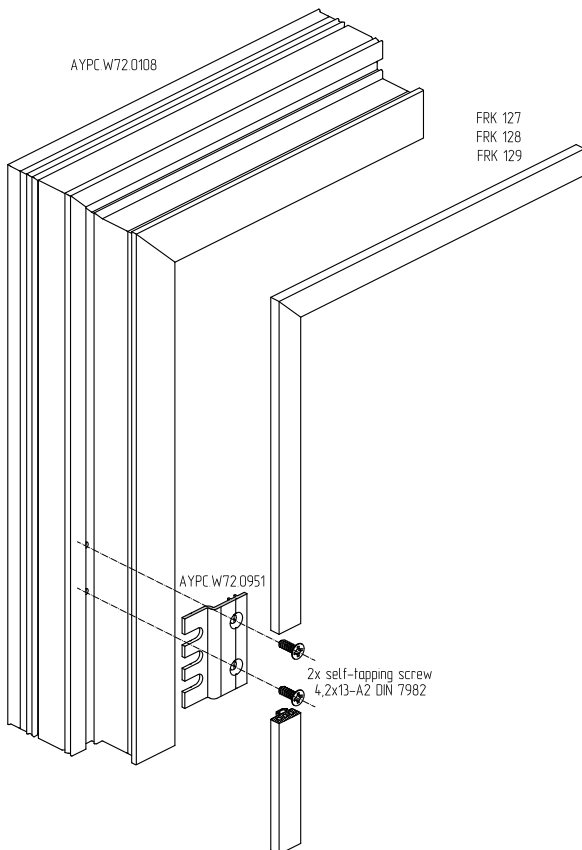

Fixation of window to mullion-transom framework

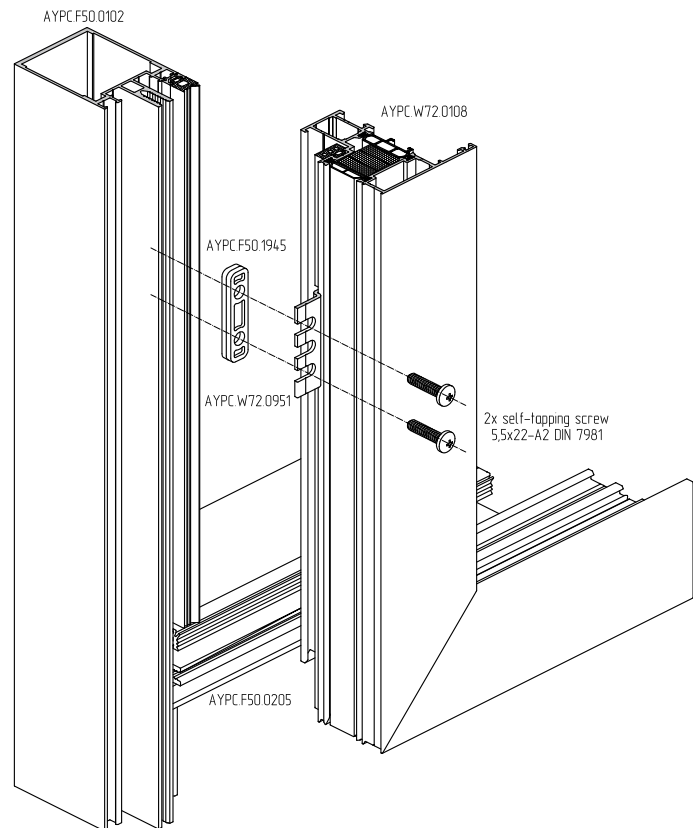

Curtain wall glazing with mounting distance inserts depending on type of profile integrated

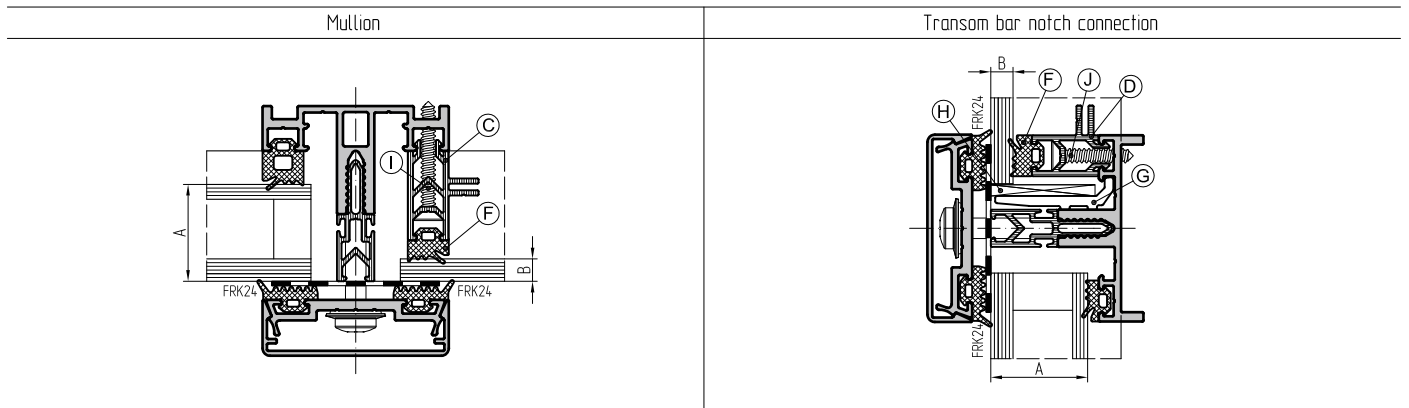

Glass thickness A	Glass thickness B	Distance profile on the mullion C	Distance profile on the transom notch connection D	Gasket on the distance profiles F	Support for glass			Self-tapping screw ø 3,9 DIN7982 I/J/K
					Bearing G	Levelling H		
22-26 mm	4 mm	AYPC.F50.0902	AYPC.F50.0901	FRK16	AYPC.F50.0941	100x26	x1 x2 x3	x32/x25/x25
	6 mm	AYPC.F50.0902	AYPC.F50.0901	FRK15	AYPC.F50.0941	100x26	x1 x2 x3	x32/x25/x25
	8 mm	AYPC.F50.0902	AYPC.F50.0901	FRK14	AYPC.F50.0941	100x26	x1 x2 x3	x32/x25/x25
28-32 mm	4 mm	AYPC.F50.0903	AYPC.F50.0902	FRK16	AYPC.F50.0941-01	100x32	x1 x2 x3	x38/x32/x32
	6 mm	AYPC.F50.0903	AYPC.F50.0902	FRK15	AYPC.F50.0941-01	100x32	x1 x2 x3	x38/x32/x32
	8 mm	AYPC.F50.0903	AYPC.F50.0902	FRK14	AYPC.F50.0941-01	100x32	x1 x2 x3	x38/x32/x32
34-38 mm	4 mm	AYPC.F50.0903	AYPC.F50.0902	FRK19	AYPC.F50.0941-02	100x38	x1 x2 x3	x38/x32/x32
	6 mm	AYPC.F50.0903	AYPC.F50.0902	FRK18	AYPC.F50.0941-02	100x38	x1 x2 x3	x38/x32/x32
	8 mm	AYPC.F50.0903	AYPC.F50.0902	FRK17	AYPC.F50.0941-02	100x38	x1 x2 x3	x38/x32/x32
40-44 mm	4 mm	AYPC.F50.0902+AYPC.F50.0901	AYPC.F50.0901+AYPC.F50.0901	FRK16	AYPC.F50.0952	100x44	x1 x2 x3	x50/x45/x45
	6 mm			FRK15	AYPC.F50.0952	100x44	x1 x2 x3	x50/x45/x45
	8 mm			FRK14	AYPC.F50.0952	100x44	x1 x2 x3	x50/x45/x45
46-50 mm	4 mm	AYPC.F50.0902+AYPC.F50.0901	AYPC.F50.0901+AYPC.F50.0901	FRK19	AYPC.F50.0952-01	100x50	x1 x2 x3	x50/x45/x45
	6 mm			FRK18	AYPC.F50.0952-01	100x50	x1 x2 x3	x50/x45/x45
	8 mm			FRK17	AYPC.F50.0952-01	100x50	x1 x2 x3	x50/x45/x45
52-56 mm	4 mm	AYPC.F50.0903+AYPC.F50.0902	AYPC.F50.0902+AYPC.F50.0902	FRK16	AYPC.F50.0952-02	100x56	x1 x2 x3	x60/x60/x60
	6 mm			FRK15	AYPC.F50.0952-02	100x56	x1 x2 x3	x60/x60/x60
	8 mm			FRK14	AYPC.F50.0952-02	100x56	x1 x2 x3	x60/x60/x60
58-62 mm	4 mm	AYPC.F50.0903+AYPC.F50.0902	AYPC.F50.0902+AYPC.F50.0902	FRK19	AYPC.F50.0952-03	100x62	x1 x2 x3	x60/x60/x60
	6 mm			FRK18	AYPC.F50.0952-03	100x62	x1 x2 x3	x60/x60/x60
	8 mm			FRK17	AYPC.F50.0952-03	100x62	x1 x2 x3	x60/x60/x60

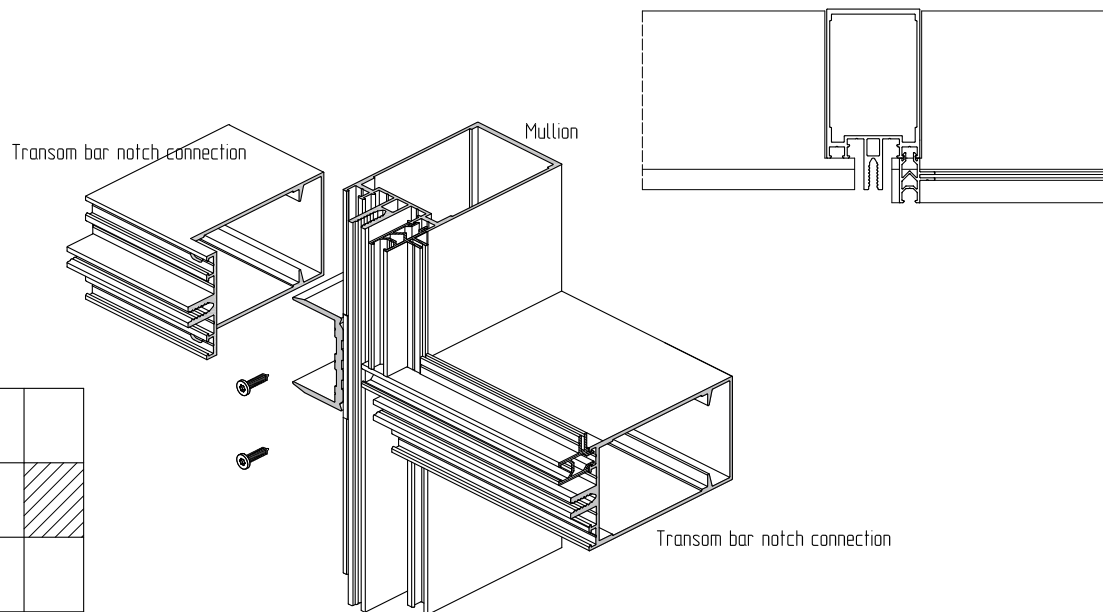

Curtain wall glazing with mounting distance inserts depending on type of profile integrated

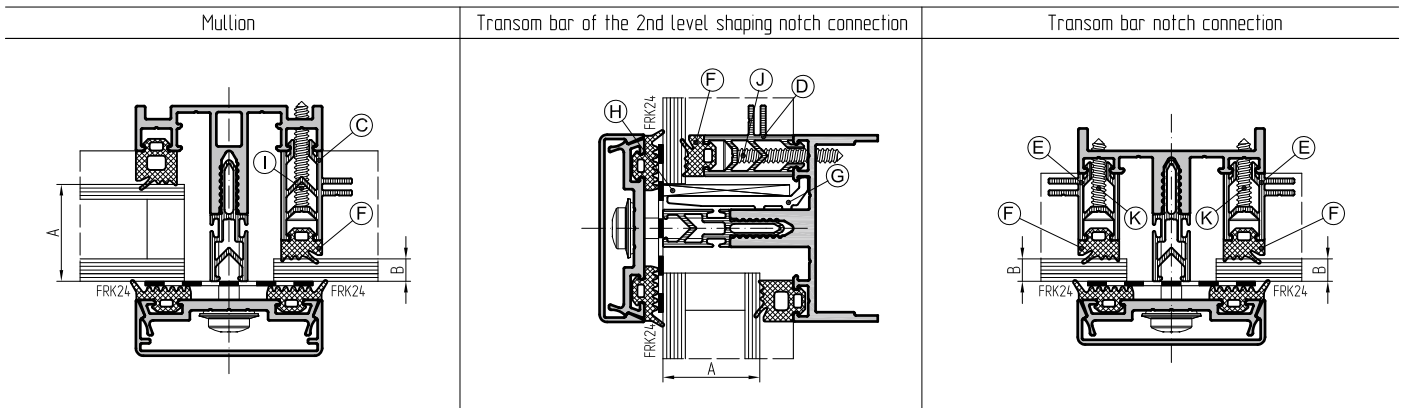

Glass thickness	Glass thickness	Distance profile on the mullion	Distance profile on the transom bar of 2nd level shaping notch connection	Distance profile on the transom bar notch connection	Gasket on the distance profiles	Support for glass		Self-tapping screw $\varnothing$ 3,9 DIN7982	
						Bearing	Levelling		
A	B	C	D	E	F	G	H	I/J/K	
22-26 mm	4 mm	AYPC.F50.0902	AYPC.F50.0902	AYPC.F50.0901	FRK16	AYPC.F50.0941-01	100x32	x1 x2 x3	x32/x32/x25
	6 mm	AYPC.F50.0902	AYPC.F50.0902	AYPC.F50.0901	FRK15	AYPC.F50.0941-01	100x32	x1 x2 x3	x32/x32/x25
	8 mm	AYPC.F50.0902	AYPC.F50.0902	AYPC.F50.0901	FRK14	AYPC.F50.0941-01	100x32	x1 x2 x3	x32/x32/x25
28-32 mm	4 mm	AYPC.F50.0903	AYPC.F50.0903	AYPC.F50.0902	FRK16	AYPC.F50.0941-02	100x38	x1 x2 x3	x38/x38/x32
	6 mm	AYPC.F50.0903	AYPC.F50.0903	AYPC.F50.0902	FRK15	AYPC.F50.0941-02	100x38	x1 x2 x3	x38/x38/x32
	8 mm	AYPC.F50.0903	AYPC.F50.0903	AYPC.F50.0902	FRK14	AYPC.F50.0941-02	100x38	x1 x2 x3	x38/x38/x32
34-38 mm	4 mm	AYPC.F50.0903	AYPC.F50.0903	AYPC.F50.0902	FRK19	AYPC.F50.0952	100x44	x1 x2 x3	x38/x38/x32
	6 mm	AYPC.F50.0903	AYPC.F50.0903	AYPC.F50.0902	FRK18	AYPC.F50.0952	100x44	x1 x2 x3	x38/x38/x32
	8 mm	AYPC.F50.0903	AYPC.F50.0903	AYPC.F50.0902	FRK17	AYPC.F50.0952	100x44	x1 x2 x3	x38/x38/x32
40-44 mm	4 mm	AYPC.F50.0902	AYPC.F50.0902	AYPC.F50.0901	FRK16	AYPC.F50.0952-01	100x50	x1 x2 x3	x50/x50/x45
	6 mm	+	+	+	FRK15	AYPC.F50.0952-01	100x50	x1 x2 x3	x50/x50/x45
	8 mm	AYPC.F50.0901	AYPC.F50.0901	AYPC.F50.0901	FRK14	AYPC.F50.0952-01	100x50	x1 x2 x3	x50/x50/x45
46-50 mm	4 mm	AYPC.F50.0902	AYPC.F50.0902	AYPC.F50.0901	FRK19	AYPC.F50.0952-02	100x56	x1 x2 x3	x50/x50/x45
	6 mm	+	+	+	FRK18	AYPC.F50.0952-02	100x56	x1 x2 x3	x50/x50/x45
	8 mm	AYPC.F50.0901	AYPC.F50.0901	AYPC.F50.0901	FRK17	AYPC.F50.0952-02	100x56	x1 x2 x3	x50/x50/x45
52-56 mm	4 mm	AYPC.F50.0903	AYPC.F50.0903	AYPC.F50.0902	FRK16	AYPC.F50.0952-03	100x62	x1 x2 x3	x60/x60/x60
	6 mm	+	+	+	FRK15	AYPC.F50.0952-03	100x62	x1 x2 x3	x60/x60/x60
	8 mm	AYPC.F50.0902	AYPC.F50.0902	AYPC.F50.0902	FRK14	AYPC.F50.0952-03	100x62	x1 x2 x3	x60/x60/x60

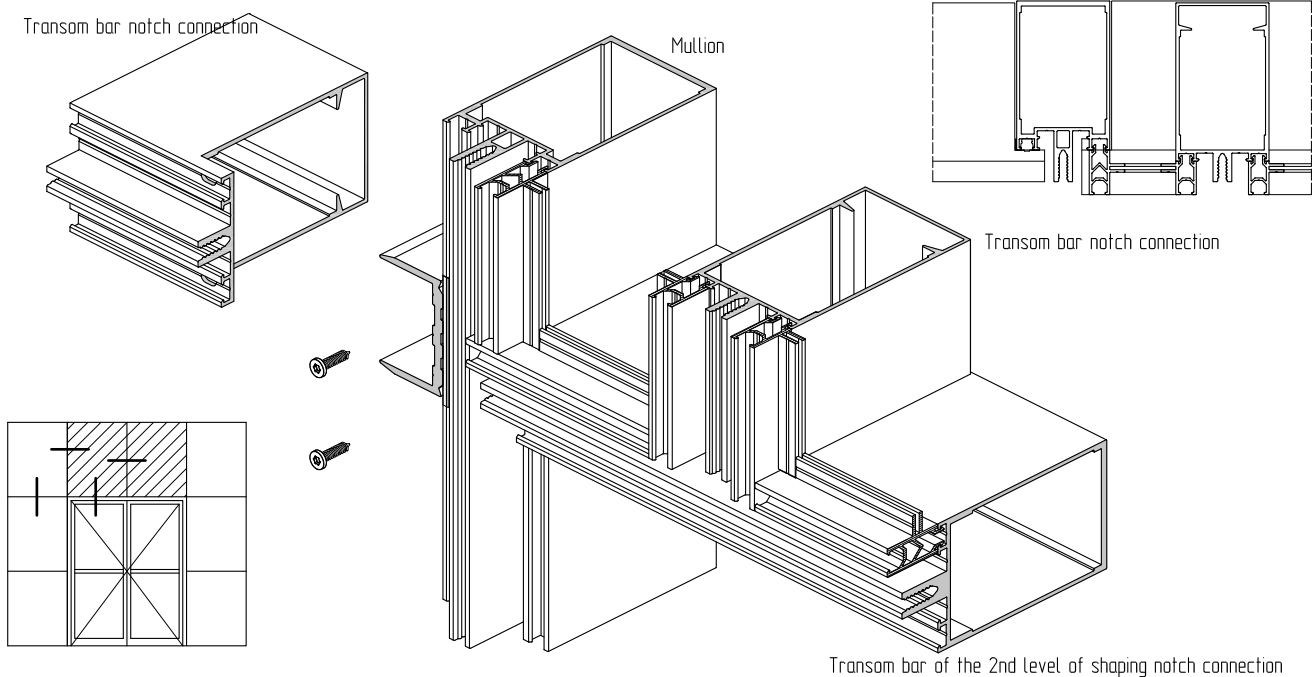

Curtain wall glazing with mounting distance insert for exterior reversible angles depending on type of profile intergration

Mullion with reversible angle  $\alpha = 7,5^\circ/15^\circ/22,5^\circ/30^\circ/37,5^\circ/45^\circ$

Transom bar notch connection

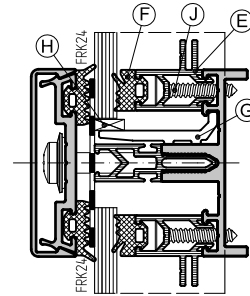
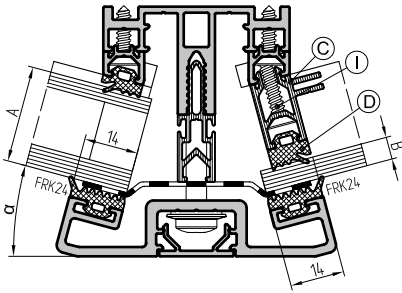

Glass thickness	Glass thickness	Distance profile on the mullion with reversible angle 15°/30°/45°	Gasket on the distance profile of mullion with reversible angle 15°/30°/45°	Distance profile on the transom bar notch connection	Gasket on the distance profile of transom bar notch	Support for glass		Self-tapping screw $\varnothing$ 3,9 DIN7982
						Bearing	Levelling	
A	B	C	D	E	F	G	H	I/J
22-26 mm	4 mm	AYPC.F50.0901	FRK16	AYPC.F50.0901	FRK16	AYPC.F50.0941	100x26 x1 x2 x3	x32/x32
	6 mm	AYPC.F50.0901	FRK15	AYPC.F50.0901	FRK15	AYPC.F50.0941	100x26 x1 x2 x3	x32/x32
	8 mm	AYPC.F50.0901	FRK14	AYPC.F50.0901	FRK14	AYPC.F50.0941	100x26 x1 x2 x3	x32/x32
28-32 mm	4 mm	AYPC.F50.0902	FRK16	AYPC.F50.0902	FRK16	AYPC.F50.0941-01	100x32 x1 x2 x3	x32/x32
	6 mm	AYPC.F50.0902	FRK15	AYPC.F50.0902	FRK15	AYPC.F50.0941-01	100x32 x1 x2 x3	x32/x32
	8 mm	AYPC.F50.0902	FRK14	AYPC.F50.0902	FRK14	AYPC.F50.0941-01	100x32 x1 x2 x3	x32/x32
34-38 mm	4 mm	AYPC.F50.0903	FRK16	AYPC.F50.0903	FRK16	AYPC.F50.0941-02	100x38 x1 x2 x3	x38/x38
	6 mm	AYPC.F50.0903	FRK15	AYPC.F50.0903	FRK15	AYPC.F50.0941-02	100x38 x1 x2 x3	x38/x38
	8 mm	AYPC.F50.0903	FRK14	AYPC.F50.0903	FRK14	AYPC.F50.0941-02	100x38 x1 x2 x3	x38/x38
40-44 mm	4 mm	AYPC.F50.0901	FRK16	AYPC.F50.0901	FRK16	AYPC.F50.0952	100x44 x1 x2 x3	x45/x45
	6 mm	+	FRK15	+	FRK15	AYPC.F50.0952	100x44 x1 x2 x3	x45/x45
	8 mm	AYPC.F50.0901	FRK14	AYPC.F50.0901	FRK14	AYPC.F50.0952	100x44 x1 x2 x3	x45/x45
46-50 mm	4 mm	AYPC.F50.0901	FRK19	AYPC.F50.0901	FRK19	AYPC.F50.0952-01	100x50 x1 x2 x3	x45/x45
	6 mm	+	FRK18	+	FRK18	AYPC.F50.0952-01	100x50 x1 x2 x3	x45/x45
	8 mm	AYPC.F50.0901	FRK17	AYPC.F50.0901	FRK17	AYPC.F50.0952-01	100x50 x1 x2 x3	x45/x45
52-56 mm	4 mm	AYPC.F50.0902	FRK16	AYPC.F50.0902	FRK16	AYPC.F50.0952-02	100x56 x1 x2 x3	x60/x60
	6 mm	+	FRK15	+	FRK15	AYPC.F50.0952-02	100x56 x1 x2 x3	x60/x60
	8 mm	AYPC.F50.0902	FRK14	AYPC.F50.0902	FRK14	AYPC.F50.0952-02	100x56 x1 x2 x3	x60/x60
58-62 mm	4 mm	AYPC.F50.0902	FRK19	AYPC.F50.0902	FRK19	AYPC.F50.0952-03	100x62 x1 x2 x3	x60/x60
	6 mm	+	FRK18	+	FRK18	AYPC.F50.0952-03	100x62 x1 x2 x3	x60/x60
	8 mm	AYPC.F50.0902	FRK17	AYPC.F50.0902	FRK17	AYPC.F50.0952-03	100x62 x1 x2 x3	x60/x60

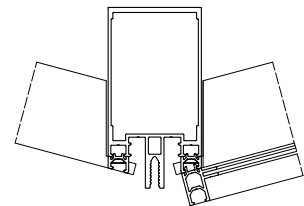
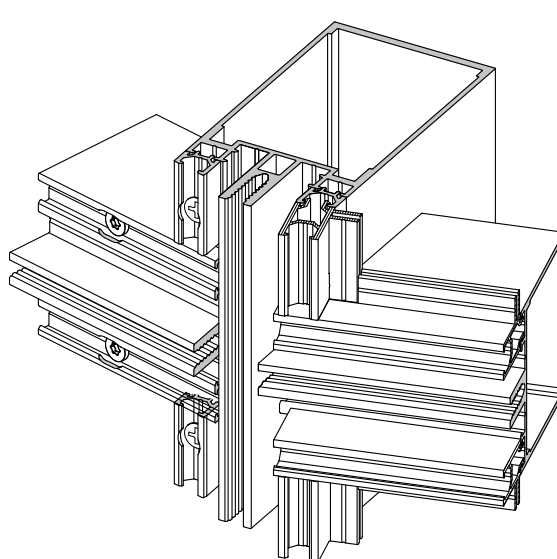
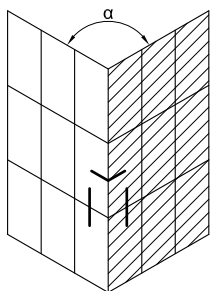







**ALUFACH ALT F50**  
CURTAIN WALL  
SYSTEM

# SECTIONS AND JOINT SOLUTIONS

10



Scale 1:1

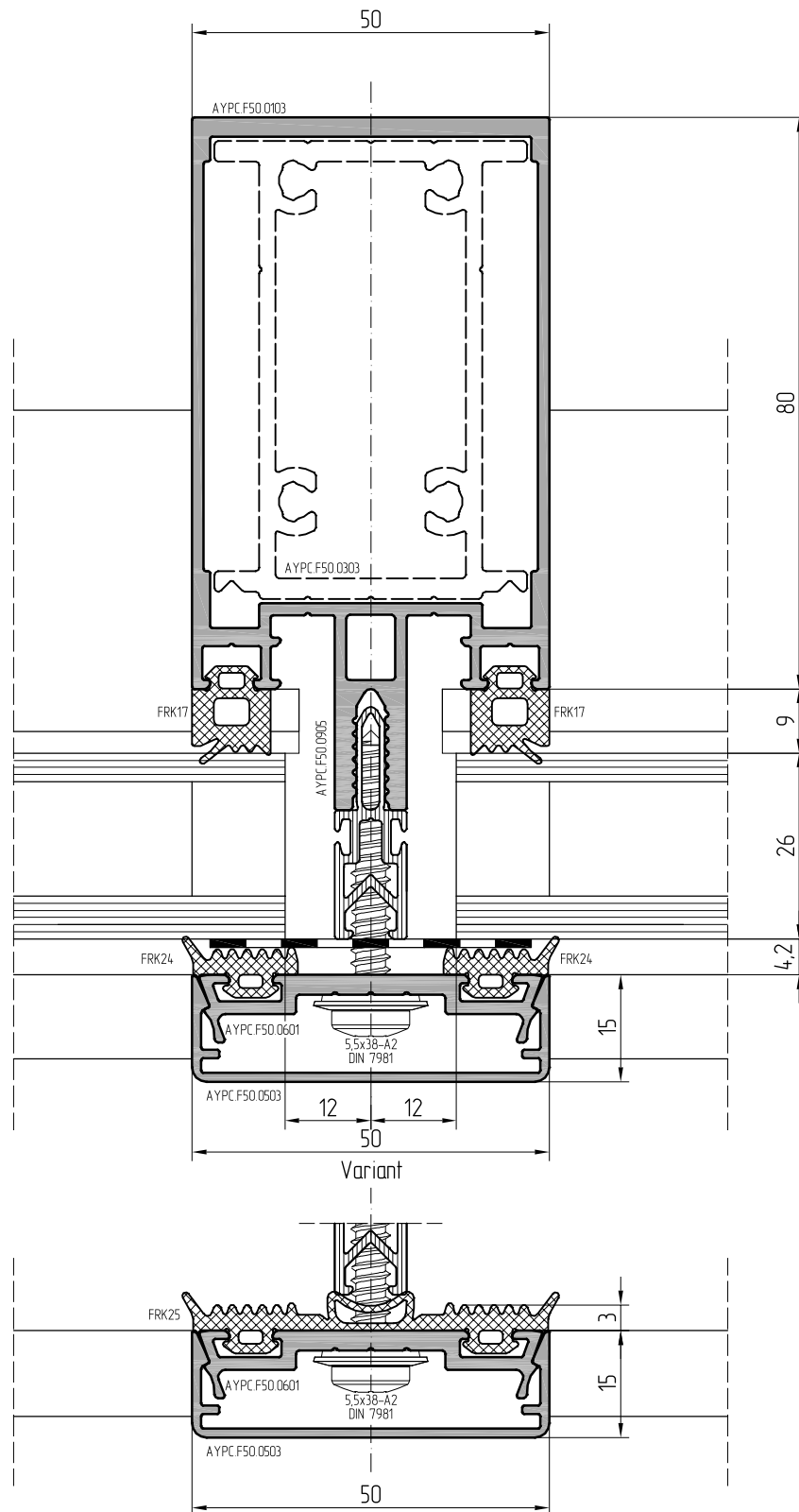
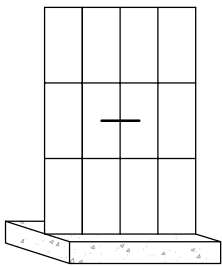

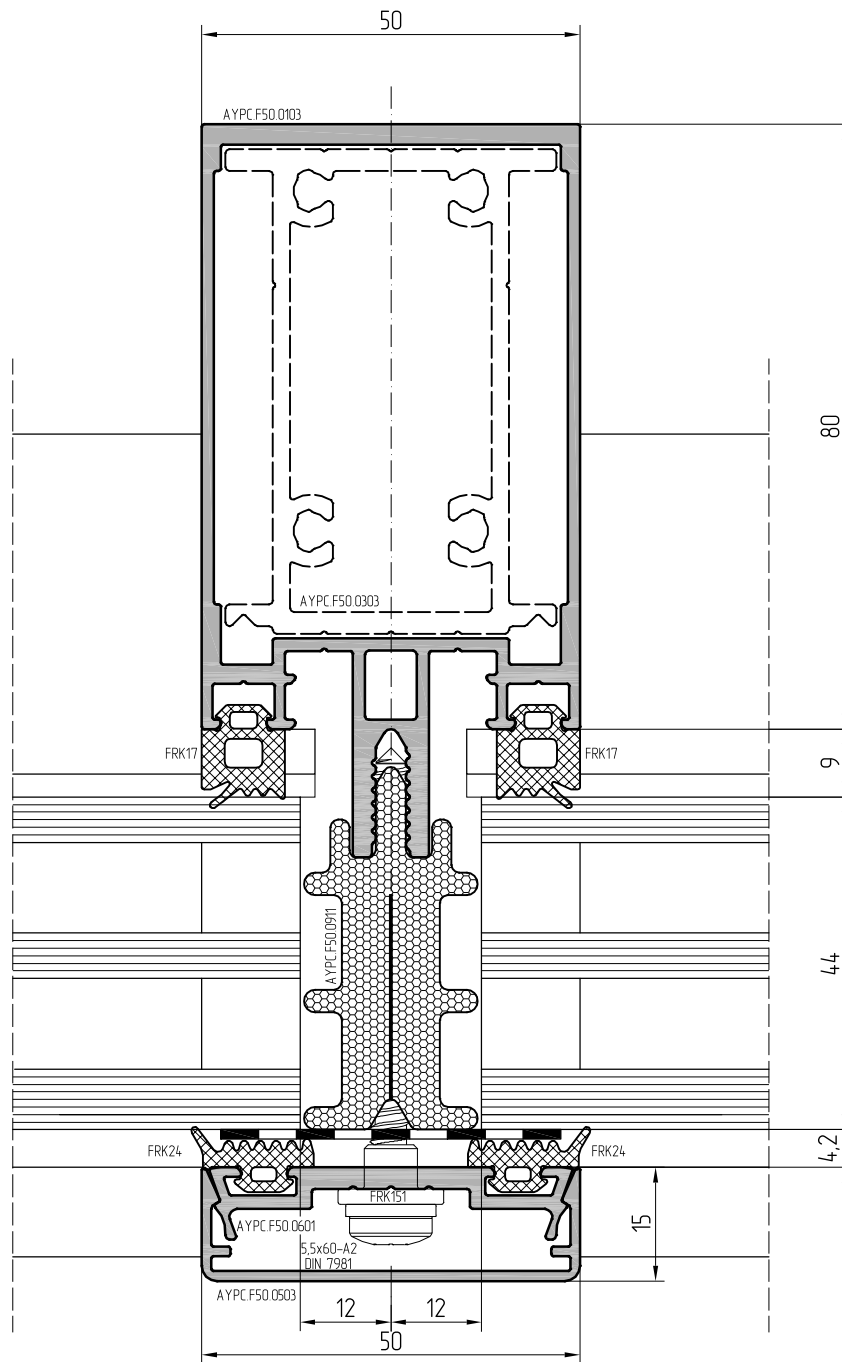
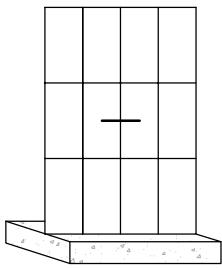



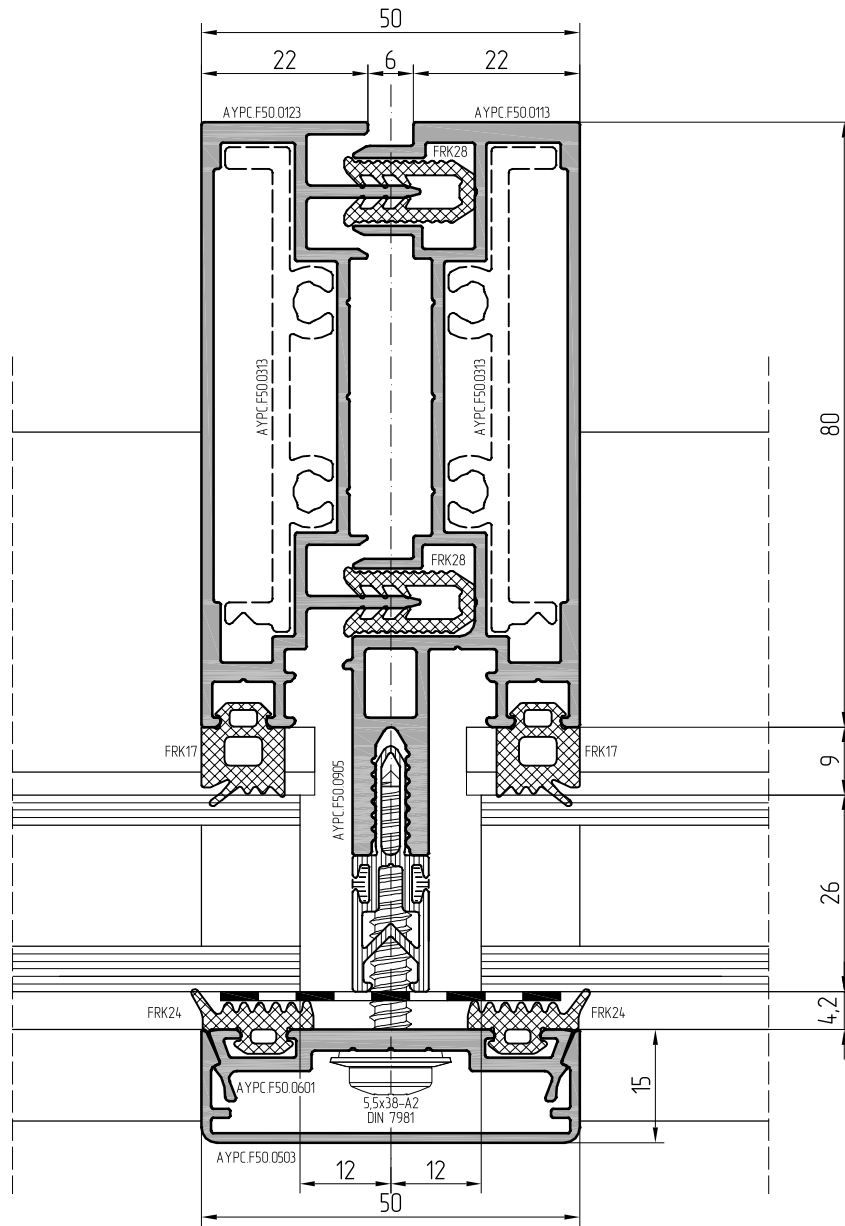
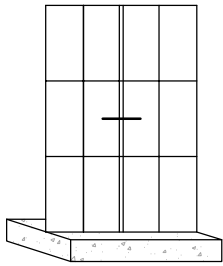

Variant

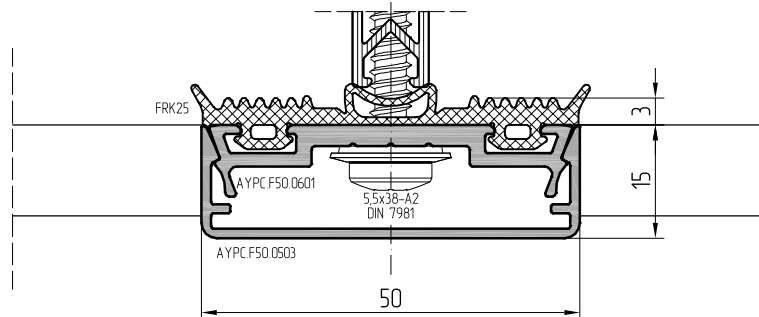

Option

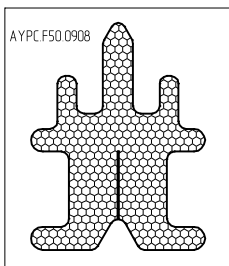

Scale 1:1

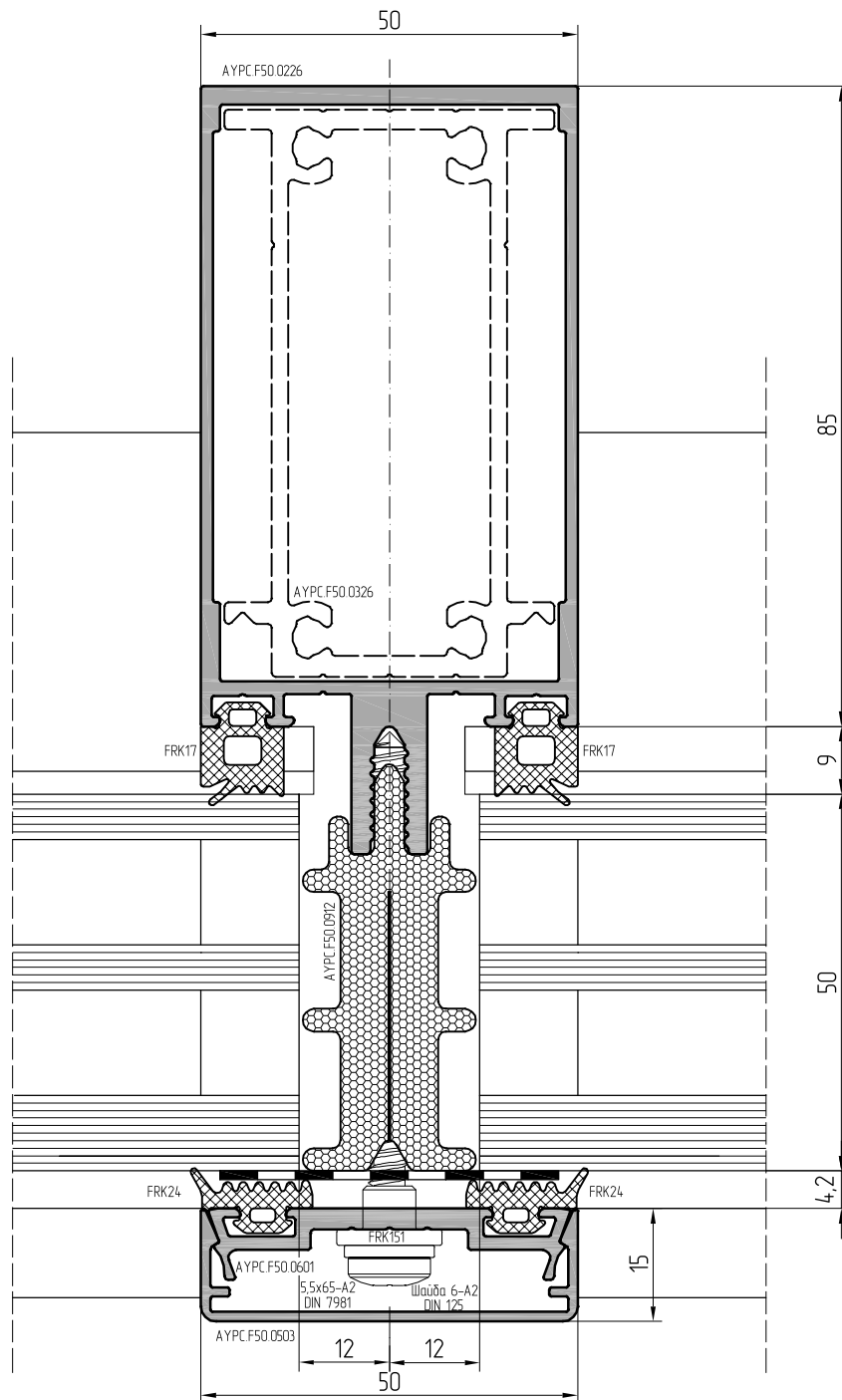
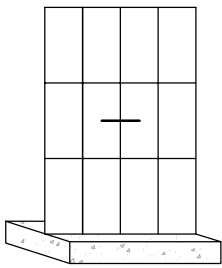

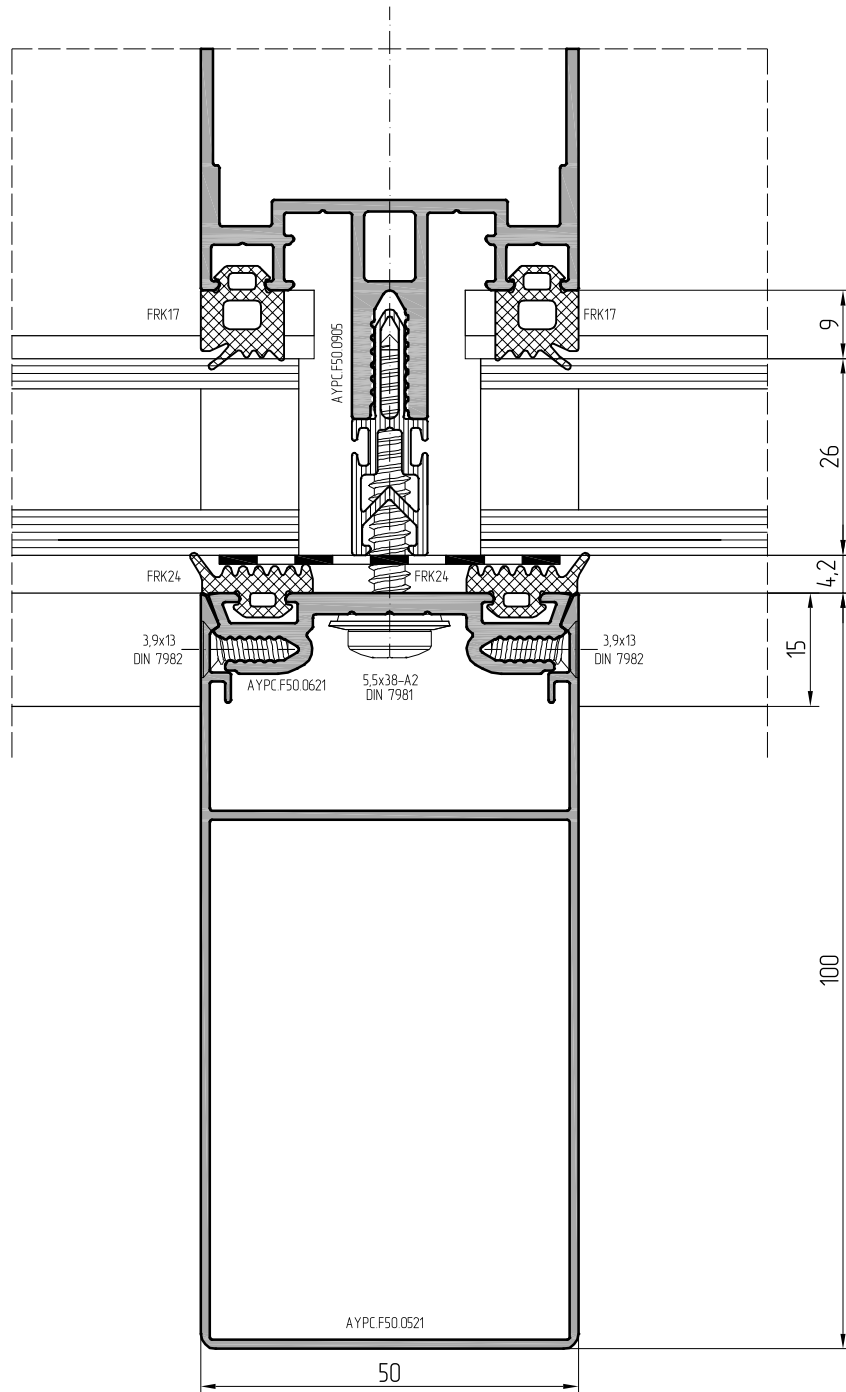
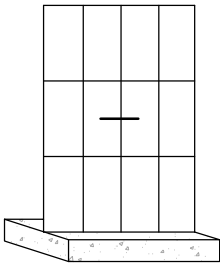

Option

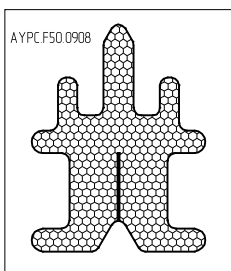



Scale 1:1

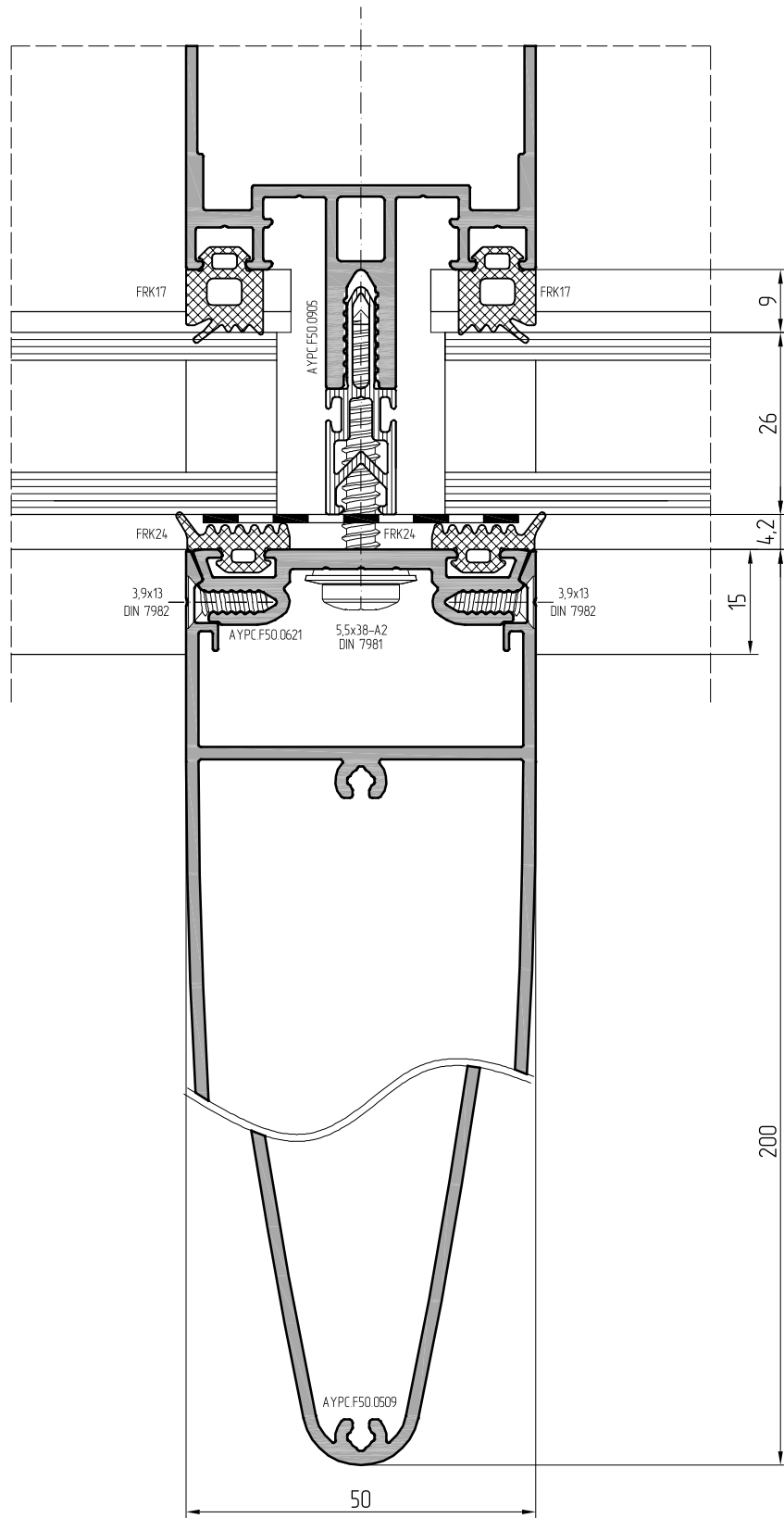
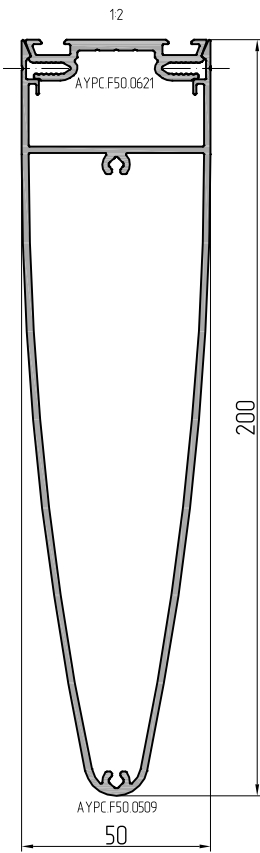
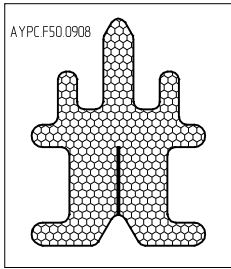
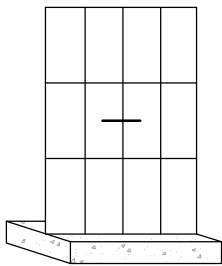

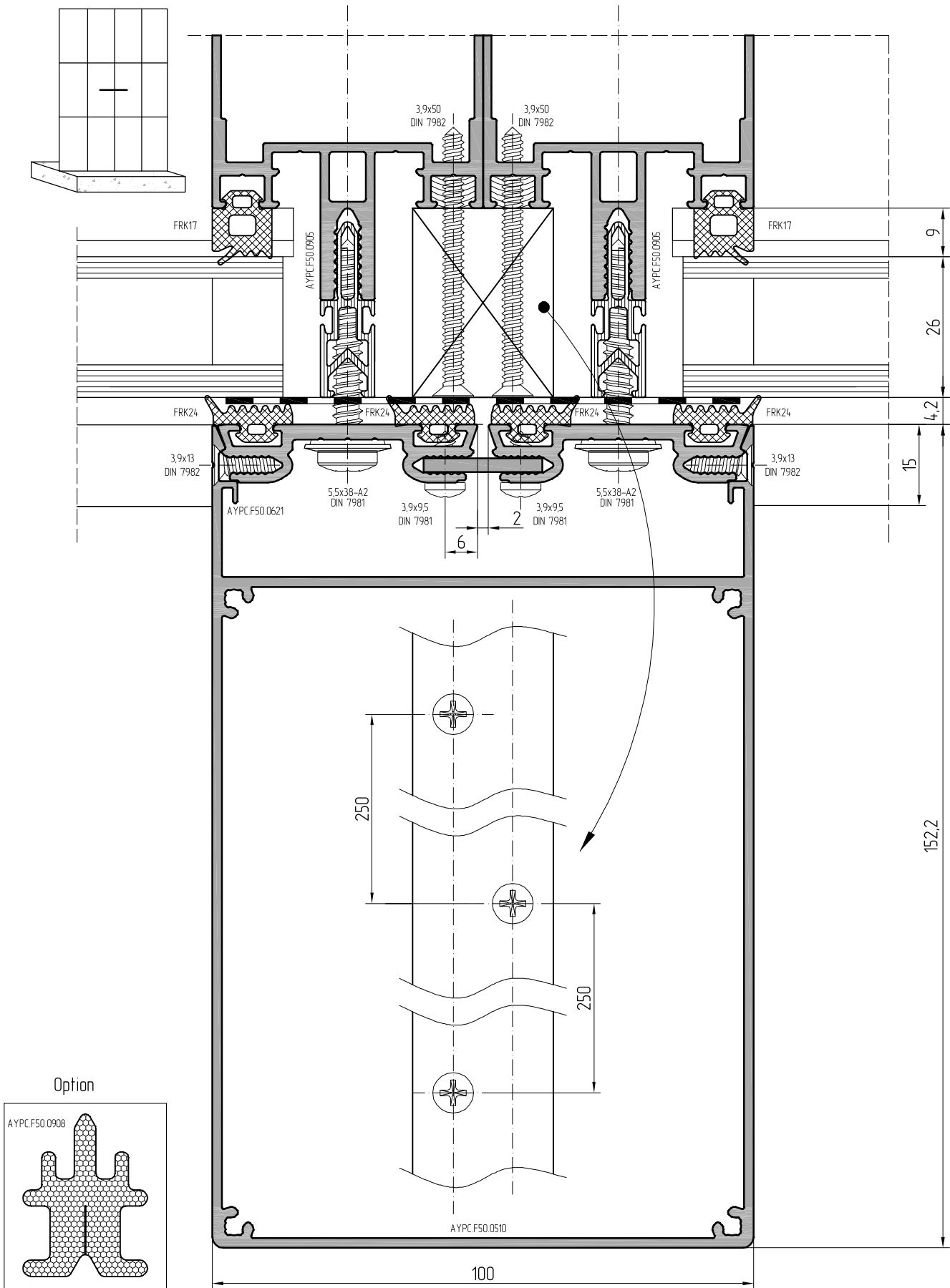

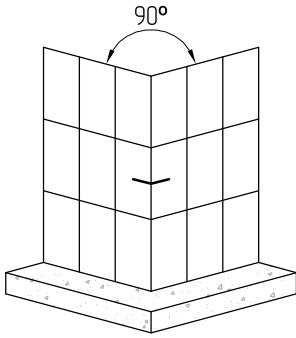

Corner cover strip					
Article	Infill unit thickness	Width L, mm	Length m	For mullion	For mullion
AYPC.F50.0992	22-26 mm	62	6,0	AYPC.F50.0102	AYPC.F50.0101
AYPC.F50.0992-01	28-32 mm	68	6,0	AYPC.F50.0102	AYPC.F50.0101
AYPC.F50.0992-02	34-38 mm	74	6,0	AYPC.F50.0102	AYPC.F50.0101
AYPC.F50.0992-03	40-44 mm	80	6,0	AYPC.F50.0102	AYPC.F50.0101
AYPC.F50.0992-04	46-50 mm	86	6,0	AYPC.F50.0102	AYPC.F50.0101
AYPC.F50.0992-05	52-56 mm	92	6,0	AYPC.F50.0102	AYPC.F50.0101

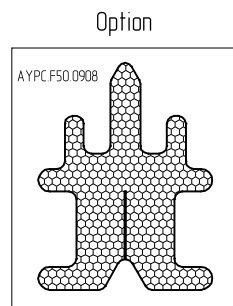
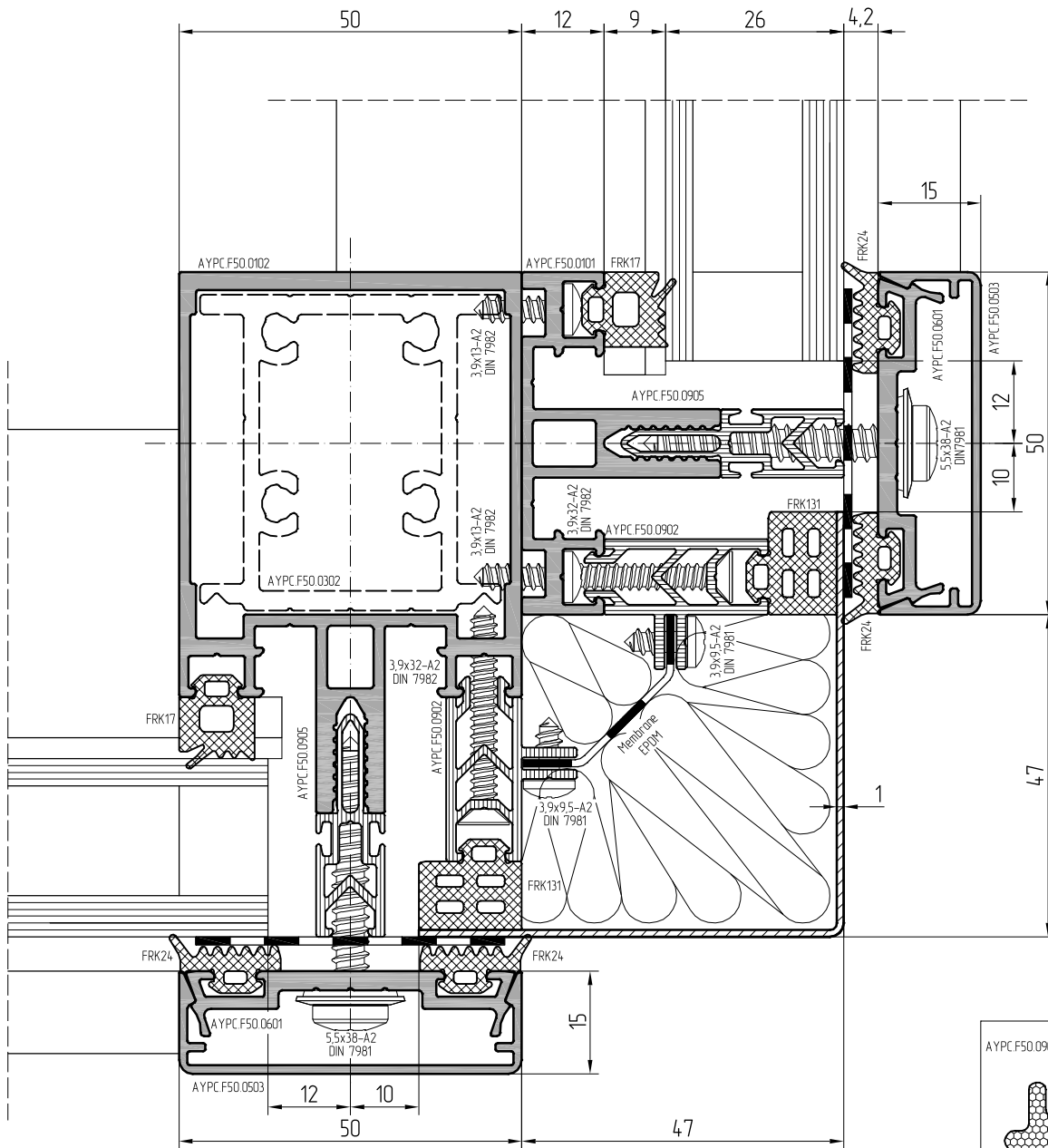

01  
02  
03  
04  
05  
06  
07  
08  
09  
10  
11  
12  
13

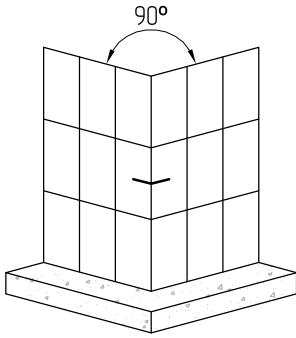

Corner cover strip				
Article	Infill unit thickness	Width L, mm	Length m	For mullion
AYPC.F50.0992-03	22-26 mm	80	6,0	AYPC.F50.0109
AYPC.F50.0992-04	28-32 mm	86	6,0	AYPC.F50.0109
AYPC.F50.0992-05	34-38 mm	92	6,0	AYPC.F50.0109
AYPC.F50.0992-06	40-44 mm	98	6,0	AYPC.F50.0109
AYPC.F50.0992-07	46-50 mm	104	6,0	AYPC.F50.0109
AYPC.F50.0992-08	52-56 mm	110	6,0	AYPC.F50.0109

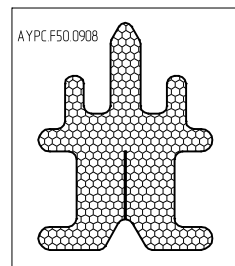
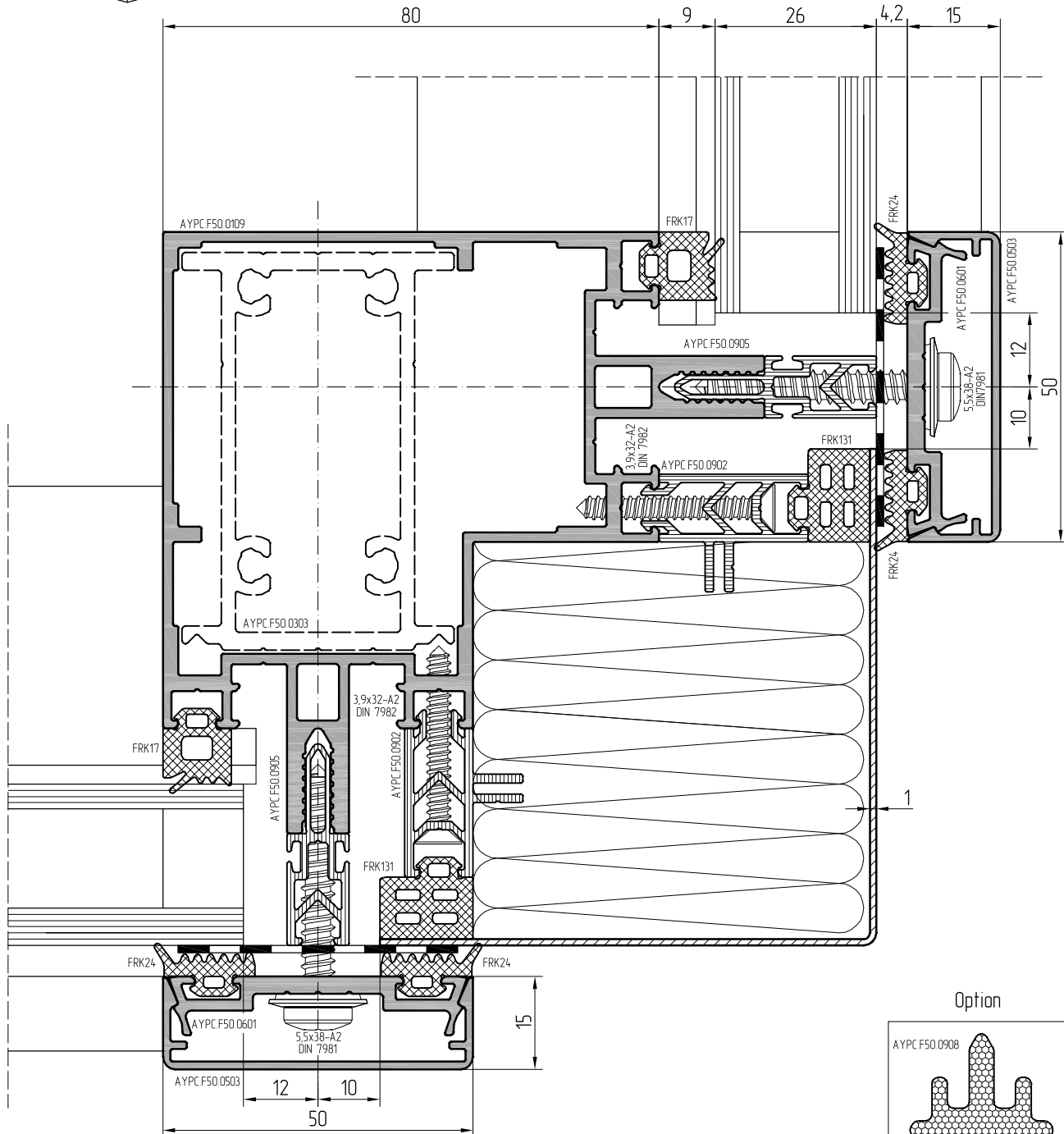

Scale 1:1

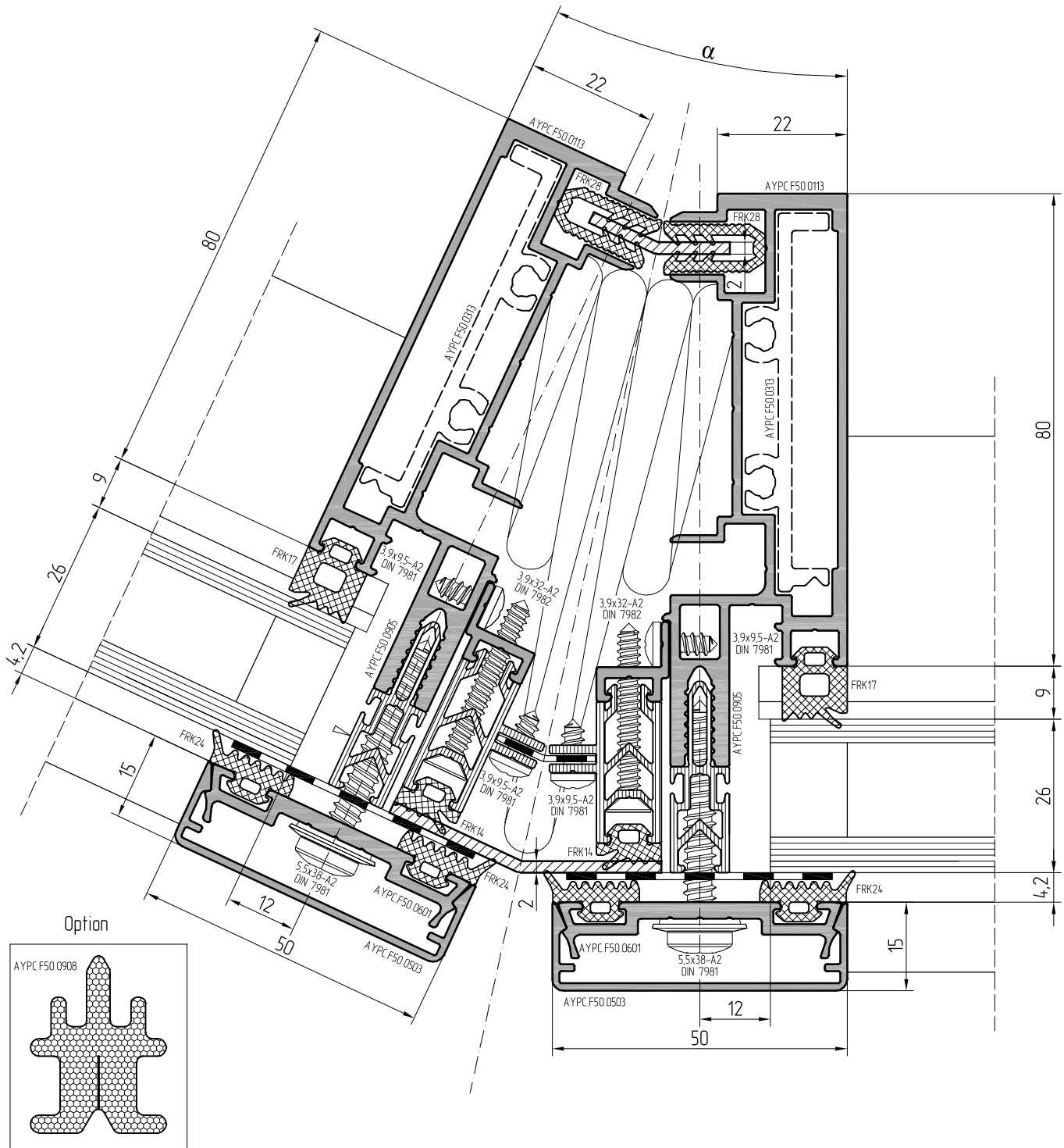
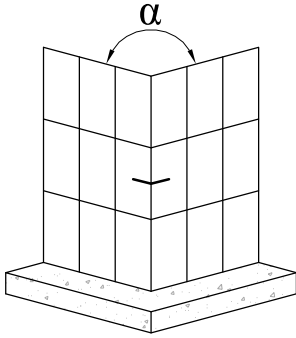

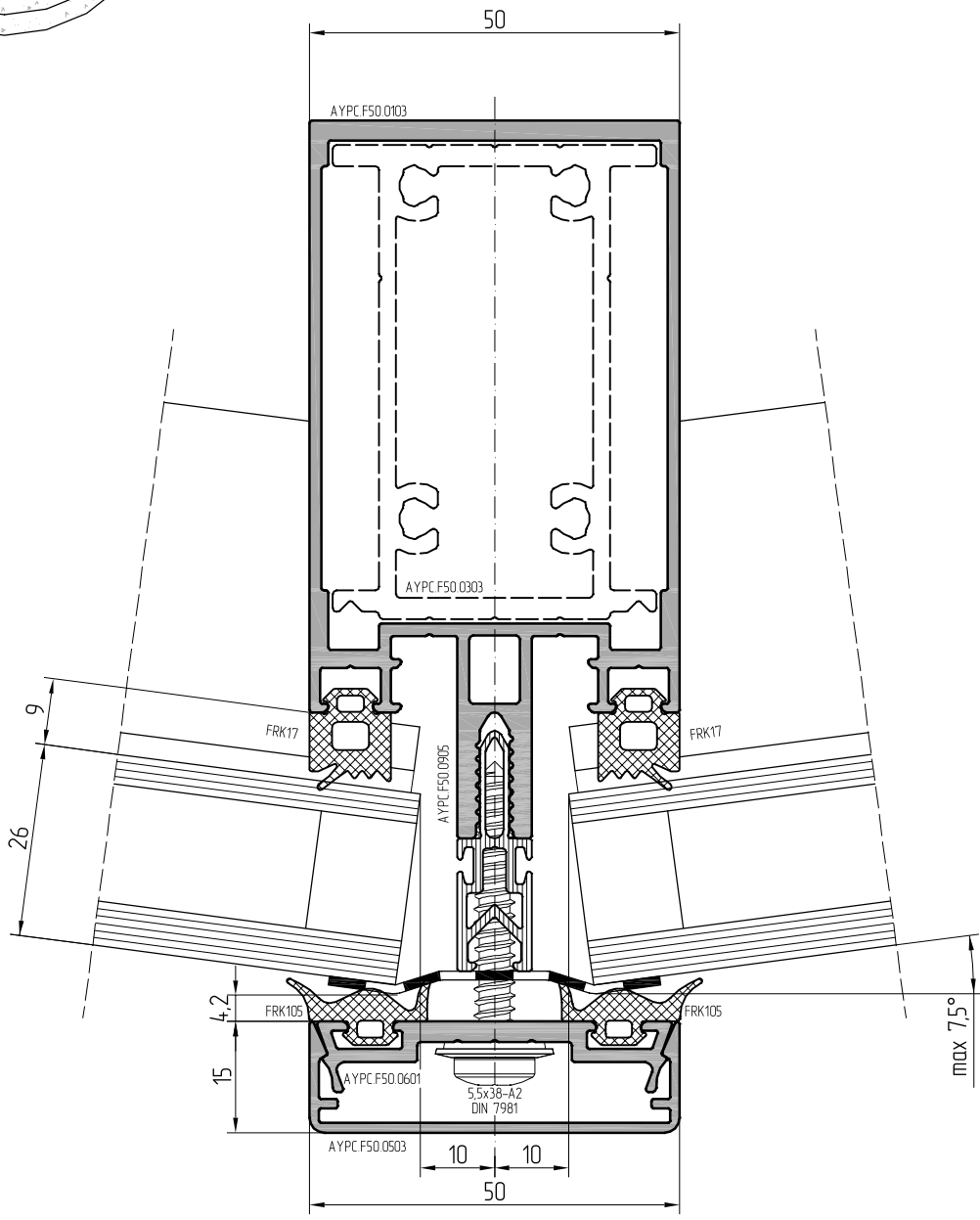
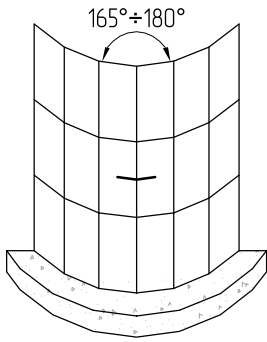

Option

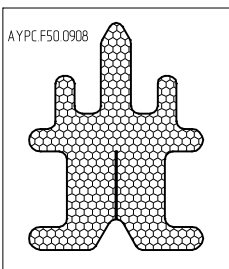

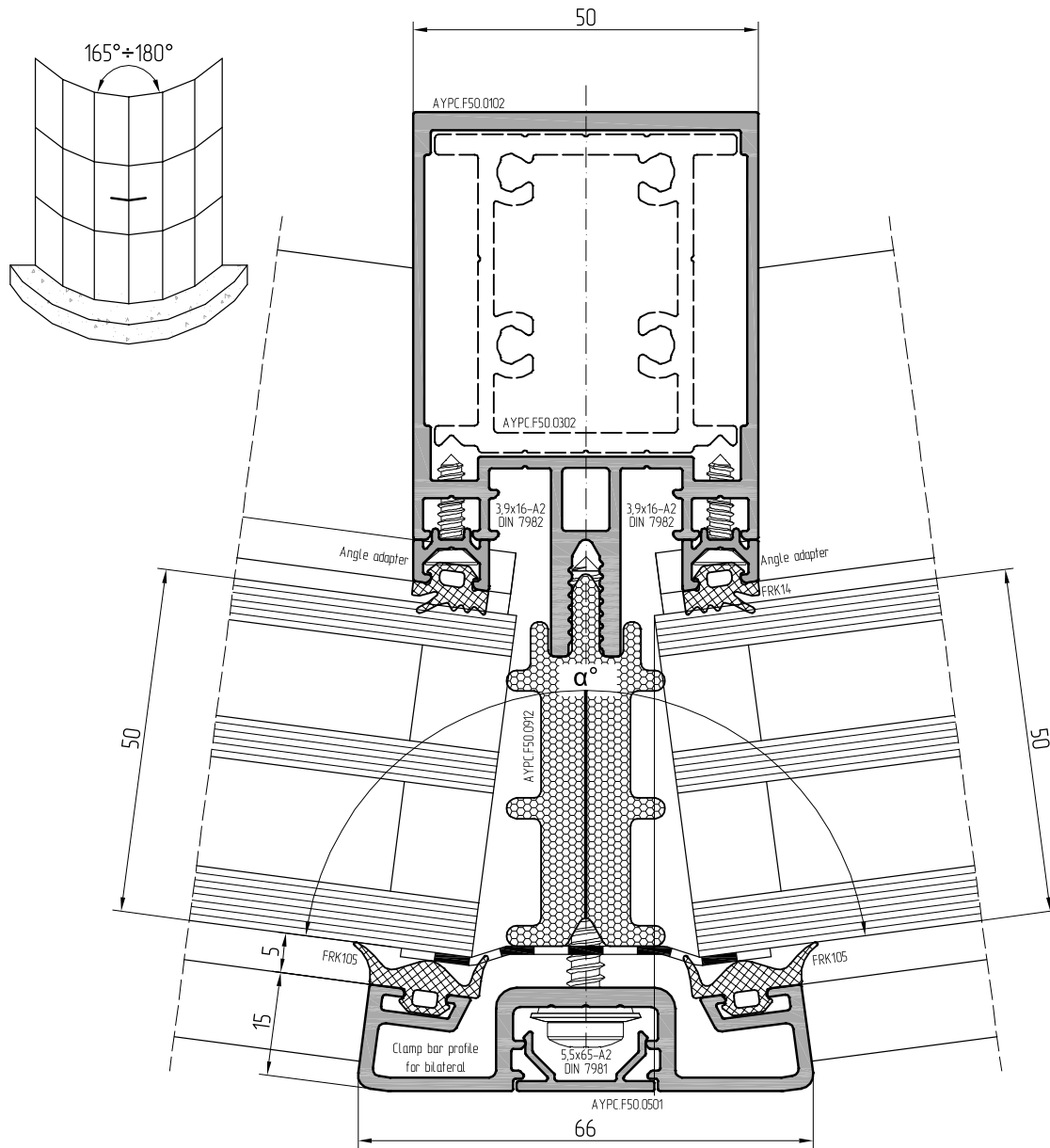

Dimension A, mm	22 - 26		28 - 32		34 - 38		40 - 44		46 - 50		52 - 56		58 - 62	
Angle $\alpha$ , °	Clamp bar profile for bilateral	Angle adapter	Clamp bar profile for bilateral	Angle adapter	Clamp bar profile for bilateral	Angle adapter	Clamp bar profile for bilateral	Angle adapter	Clamp bar profile for bilateral	Angle adapter	Clamp bar profile for bilateral	Angle adapter	Clamp bar profile for bilateral	Angle adapter
90 - 97,5	AYPC F50.0607	AYPC F50.0707	AYPC F50.0607	AYPC F50.0707	AYPC F50.0607-01	AYPC F50.0715	AYPC F50.0607-01	AYPC F50.0715	AYPC F50.0607-01	AYPC F50.0715	AYPC F50.0607-02	AYPC F50.0715	AYPC F50.0607-01	AYPC F50.0715
97,5 - 112,5	AYPC F50.0616	AYPC F50.0714	AYPC F50.0616	AYPC F50.0714	AYPC F50.0616-01	AYPC F50.0714	AYPC F50.0616-01	AYPC F50.0714	AYPC F50.0616-01	AYPC F50.0714	AYPC F50.0616-01	AYPC F50.0714	AYPC F50.0616-01	AYPC F50.0714
112,5 - 120	AYPC F50.0606	AYPC F50.0706	AYPC F50.0606	AYPC F50.0706	AYPC F50.0606-01	AYPC F50.0706	AYPC F50.0606-01	AYPC F50.0706	AYPC F50.0606-01	AYPC F50.0706	AYPC F50.0606-01	AYPC F50.0706	AYPC F50.0606-01	AYPC F50.0706
120 - 127,5	AYPC F50.0606	AYPC F50.0706	AYPC F50.0606	AYPC F50.0706	AYPC F50.0606	AYPC F50.0706	AYPC F50.0606-01	AYPC F50.0706	AYPC F50.0606-01	AYPC F50.0706	AYPC F50.0606-01	AYPC F50.0706	AYPC F50.0606-01	AYPC F50.0706
127,5 - 139	AYPC F50.0615	AYPC F50.0713	AYPC F50.0615	AYPC F50.0713	AYPC F50.0615-01	AYPC F50.0713	AYPC F50.0615-01	AYPC F50.0713	AYPC F50.0615-01	AYPC F50.0713	AYPC F50.0615-01	AYPC F50.0713	AYPC F50.0615-01	AYPC F50.0713
139 - 142,5	AYPC F50.0615	AYPC F50.0713	AYPC F50.0615	AYPC F50.0713	AYPC F50.0615	AYPC F50.0713	AYPC F50.0615-01	AYPC F50.0713	AYPC F50.0615-01	AYPC F50.0713	AYPC F50.0615-01	AYPC F50.0713	AYPC F50.0615-01	AYPC F50.0713
142,5 - 150	AYPC F50.0605-01	AYPC F50.0705	AYPC F50.0605-01	AYPC F50.0705	AYPC F50.0605-01	AYPC F50.0705	AYPC F50.0605-01	AYPC F50.0705	AYPC F50.0605-01	AYPC F50.0705	AYPC F50.0605-01	AYPC F50.0705	AYPC F50.0605-01	AYPC F50.0705
150 - 157,5	AYPC F50.0605	AYPC F50.0705	AYPC F50.0605	AYPC F50.0705	AYPC F50.0605-01	AYPC F50.0705	AYPC F50.0605-01	AYPC F50.0705	AYPC F50.0605-01	AYPC F50.0705	AYPC F50.0605-01	AYPC F50.0705	AYPC F50.0605-01	AYPC F50.0705
157,5 - 165	AYPC F50.0614	AYPC F50.0712	AYPC F50.0614	AYPC F50.0712	AYPC F50.0614-01	AYPC F50.0712	AYPC F50.0614-01	AYPC F50.0712	AYPC F50.0614-01	AYPC F50.0712	AYPC F50.0614-01	AYPC F50.0712	AYPC F50.0614-01	AYPC F50.0712
165 - 169	AYPC F50.0614	-	AYPC F50.0614	-	AYPC F50.0614	-	AYPC F50.0614	-	AYPC F50.0614	-	AYPC F50.0614-01	-	AYPC F50.0614-01	-
	AYPC F50.0614	AYPC F50.0712	AYPC F50.0614	AYPC F50.0712	AYPC F50.0614	AYPC F50.0712	AYPC F50.0614	AYPC F50.0712	AYPC F50.0614	AYPC F50.0712	AYPC F50.0614	AYPC F50.0712	AYPC F50.0614-01	AYPC F50.0712
169 - 172,5	AYPC F50.0614	-	AYPC F50.0614	-	AYPC F50.0614	-	AYPC F50.0614	-	AYPC F50.0614	-	AYPC F50.0614	-	AYPC F50.0614	-
	AYPC F50.0614	AYPC F50.0712	AYPC F50.0614	AYPC F50.0712	AYPC F50.0614	AYPC F50.0712	AYPC F50.0614	AYPC F50.0712	AYPC F50.0614	AYPC F50.0712	AYPC F50.0614	AYPC F50.0712	AYPC F50.0614-01	AYPC F50.0712
172,5 - 180	AYPC F50.6009	-	AYPC F50.6009	-	AYPC F50.6009	-	AYPC F50.6009	-	AYPC F50.6009	-	AYPC F50.6009	-	AYPC F50.6009	-

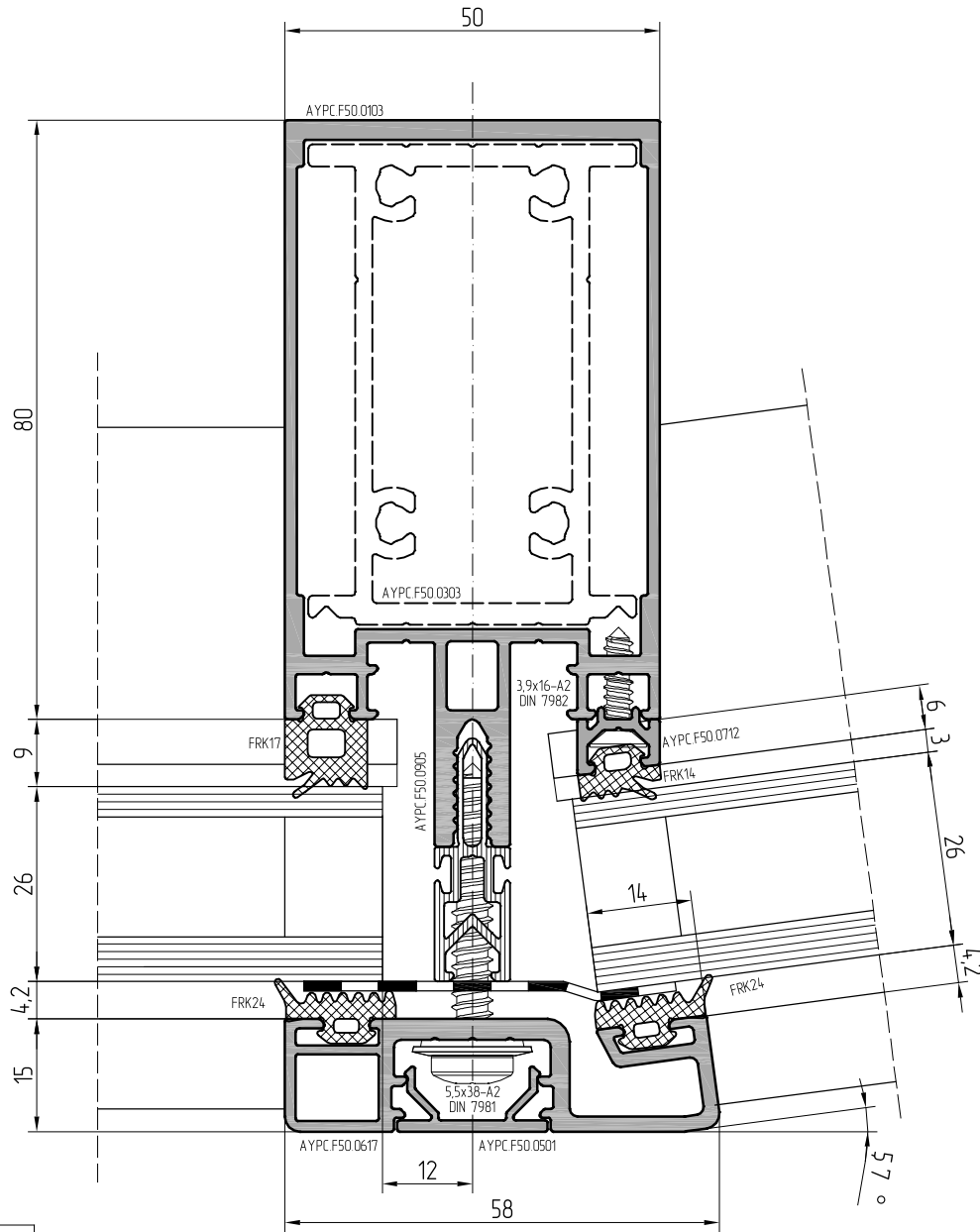
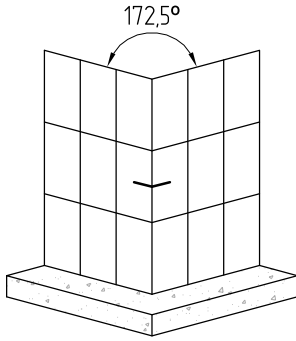

Option

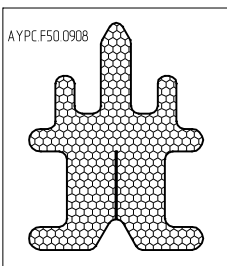



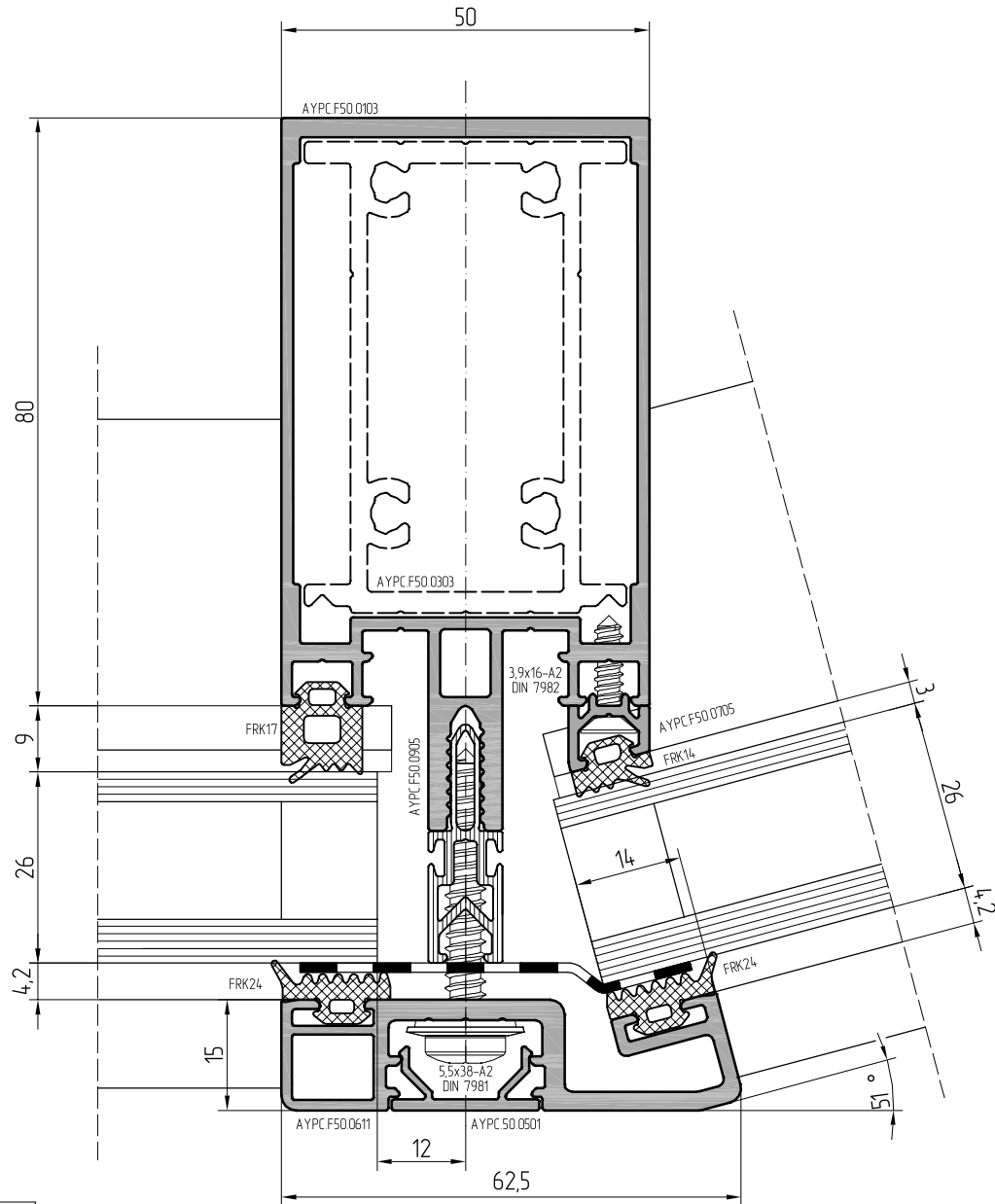
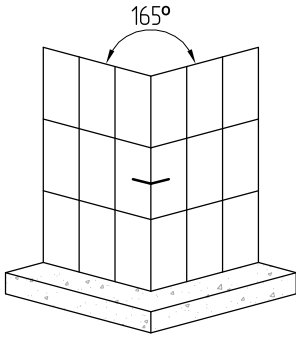

Option

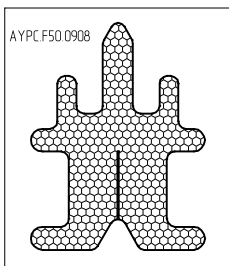

- 01
- 02
- 03
- 04
- 05
- 06
- 07
- 08
- 09
- 10
- 11
- 12
- 13

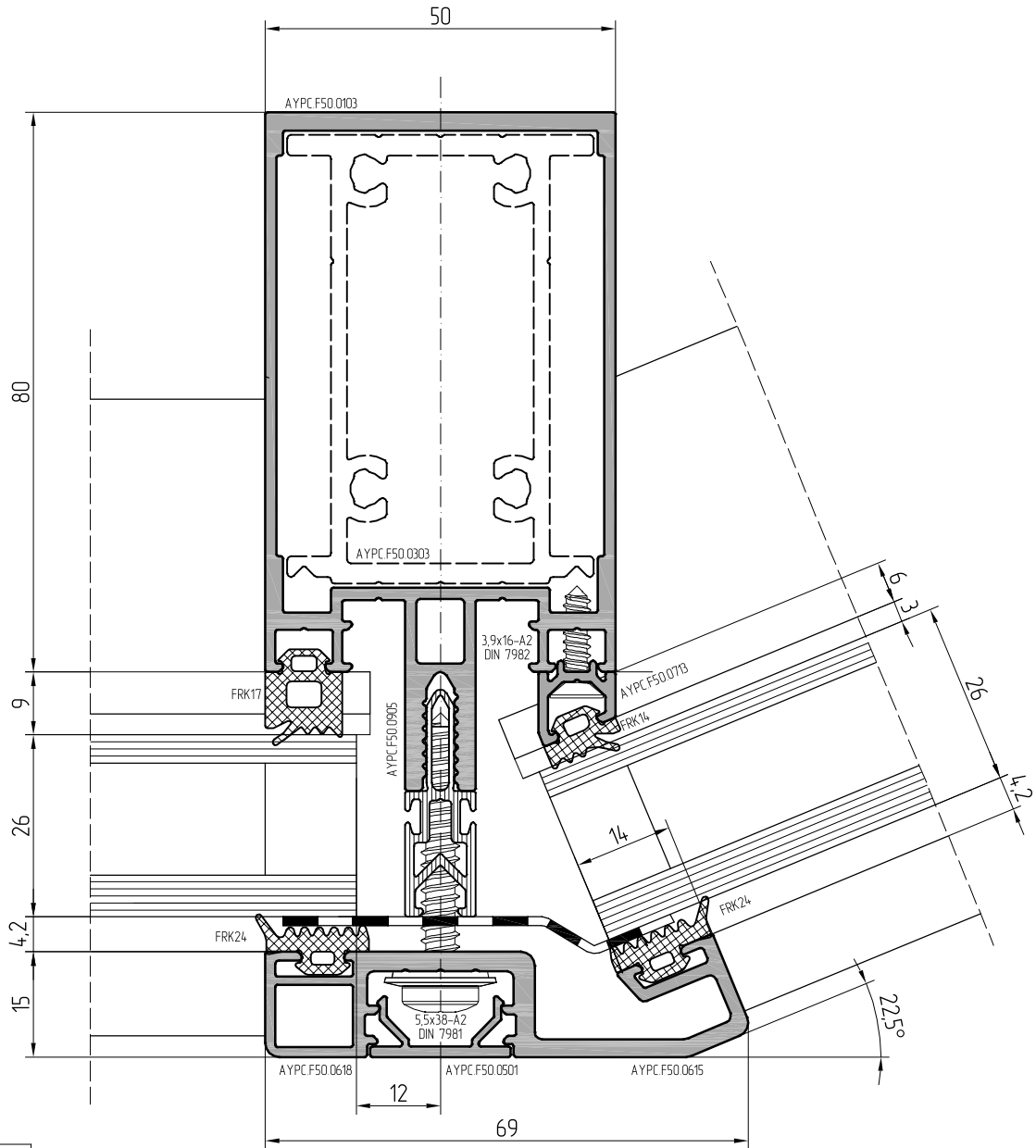
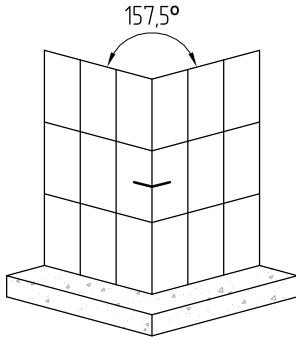

Option

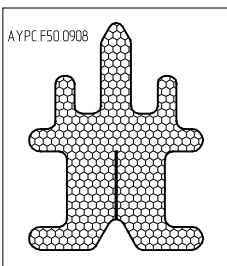

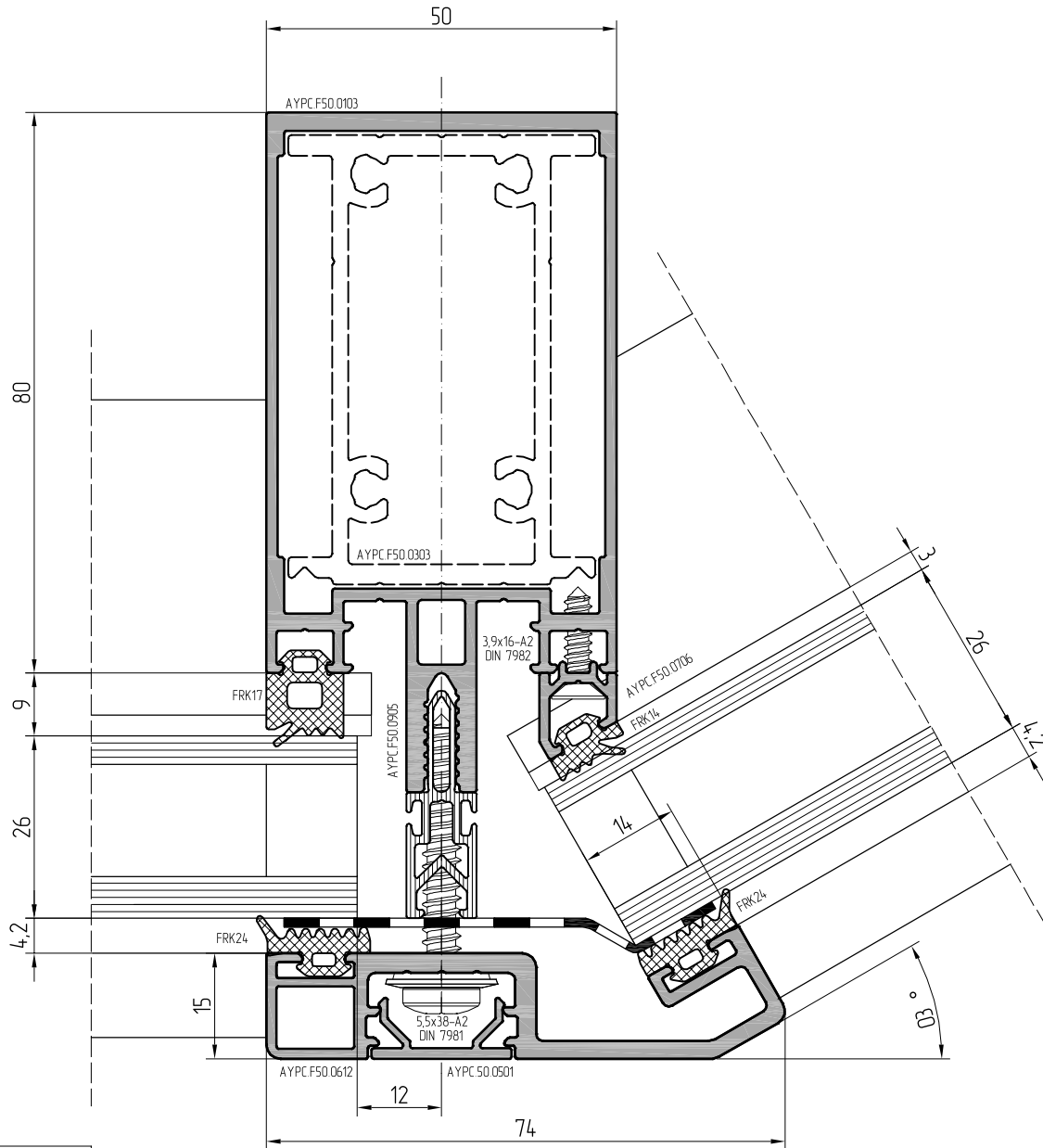
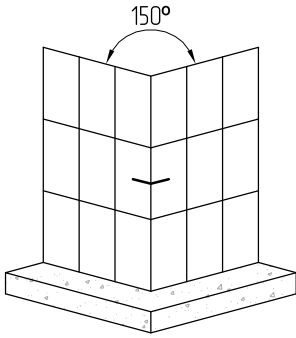

Option

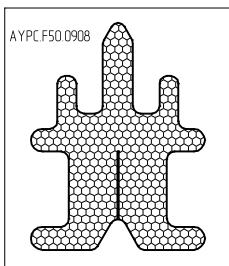

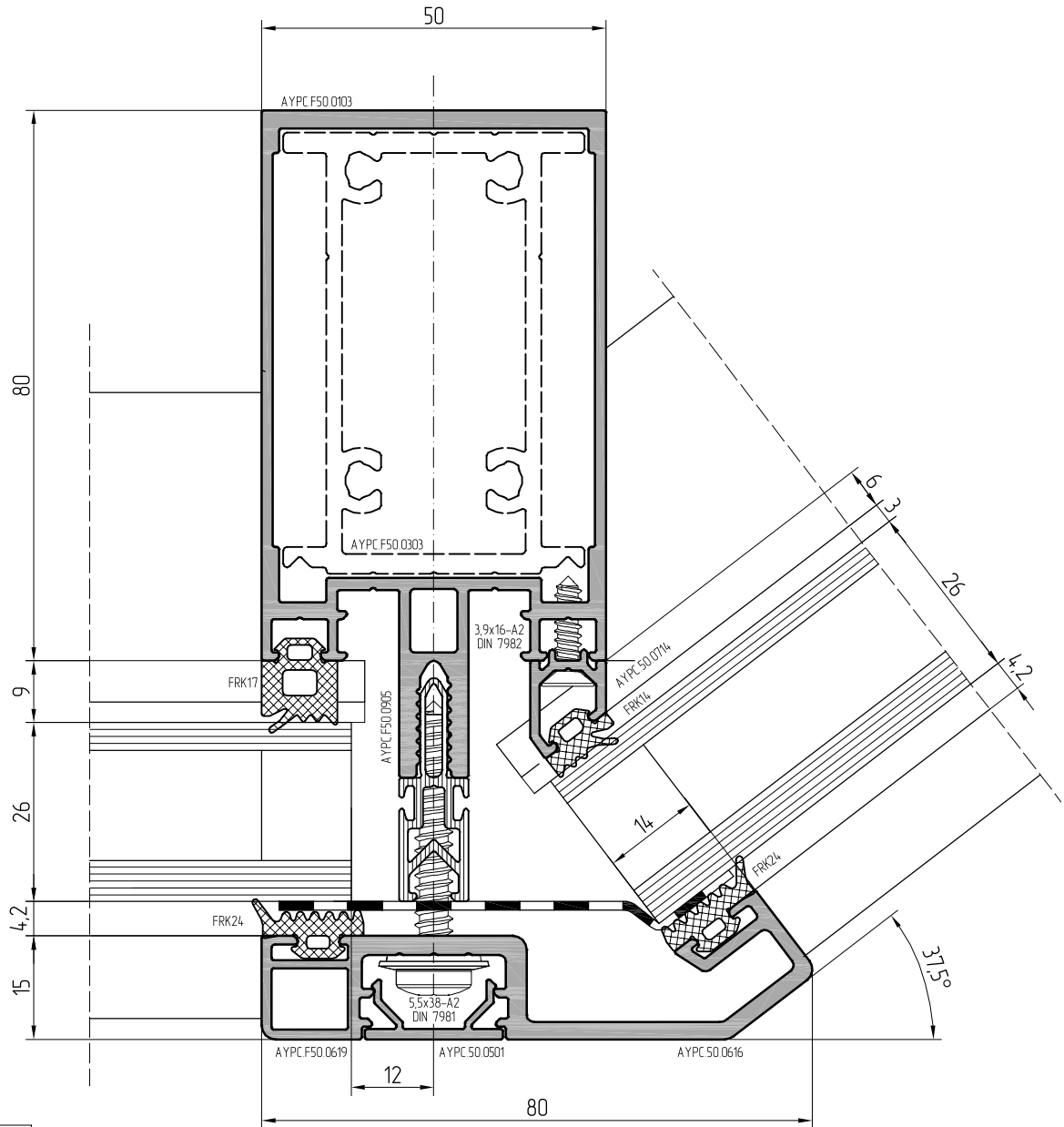
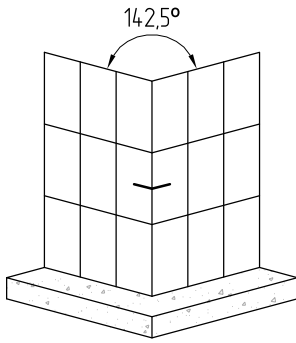

Option

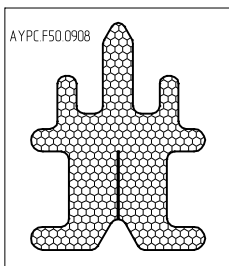

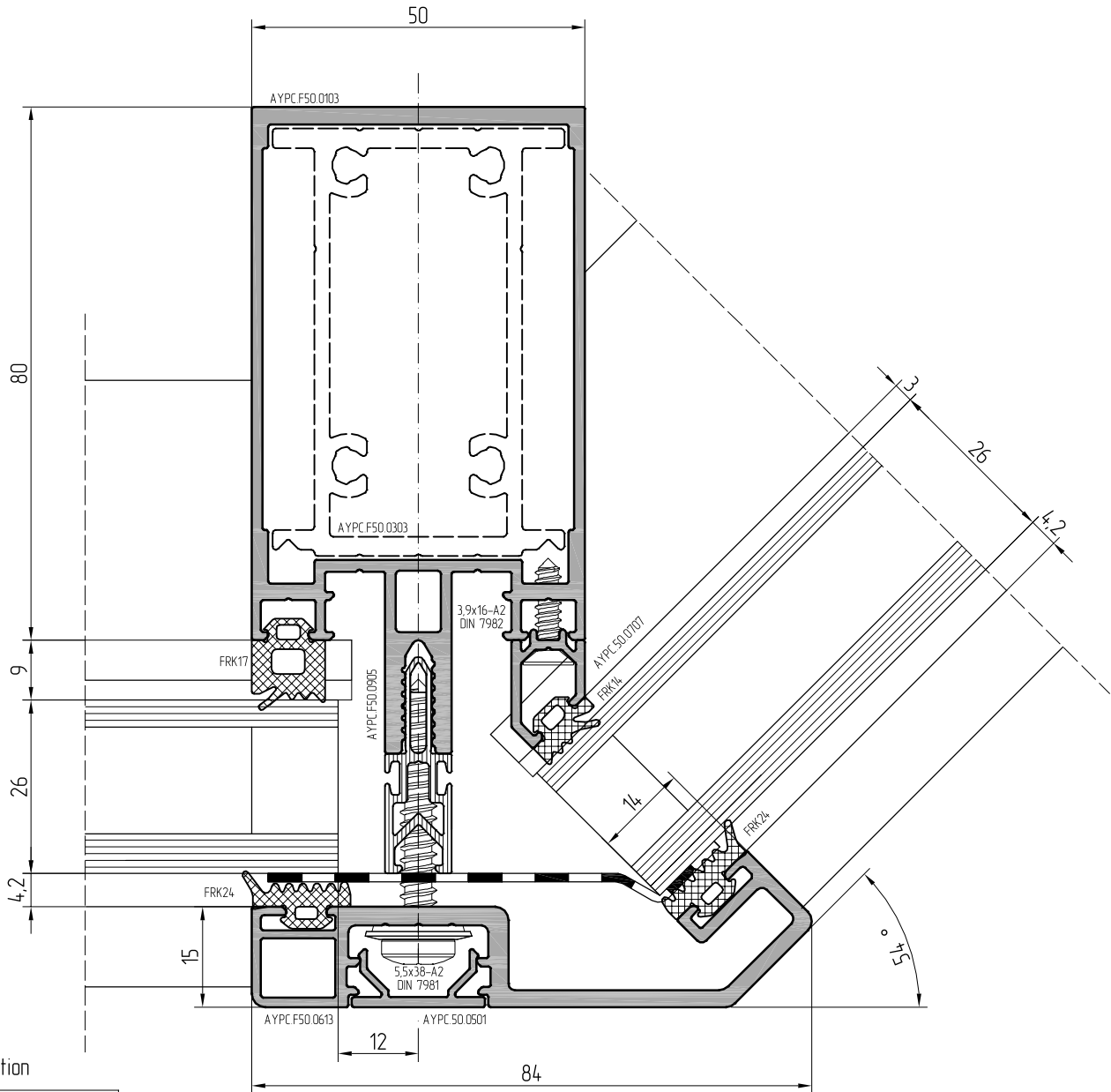
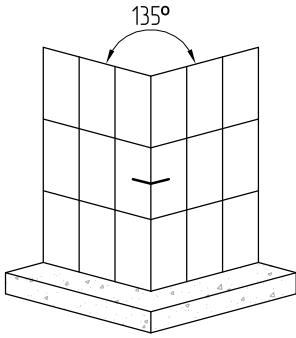

Option

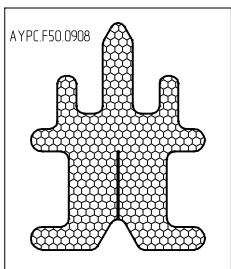

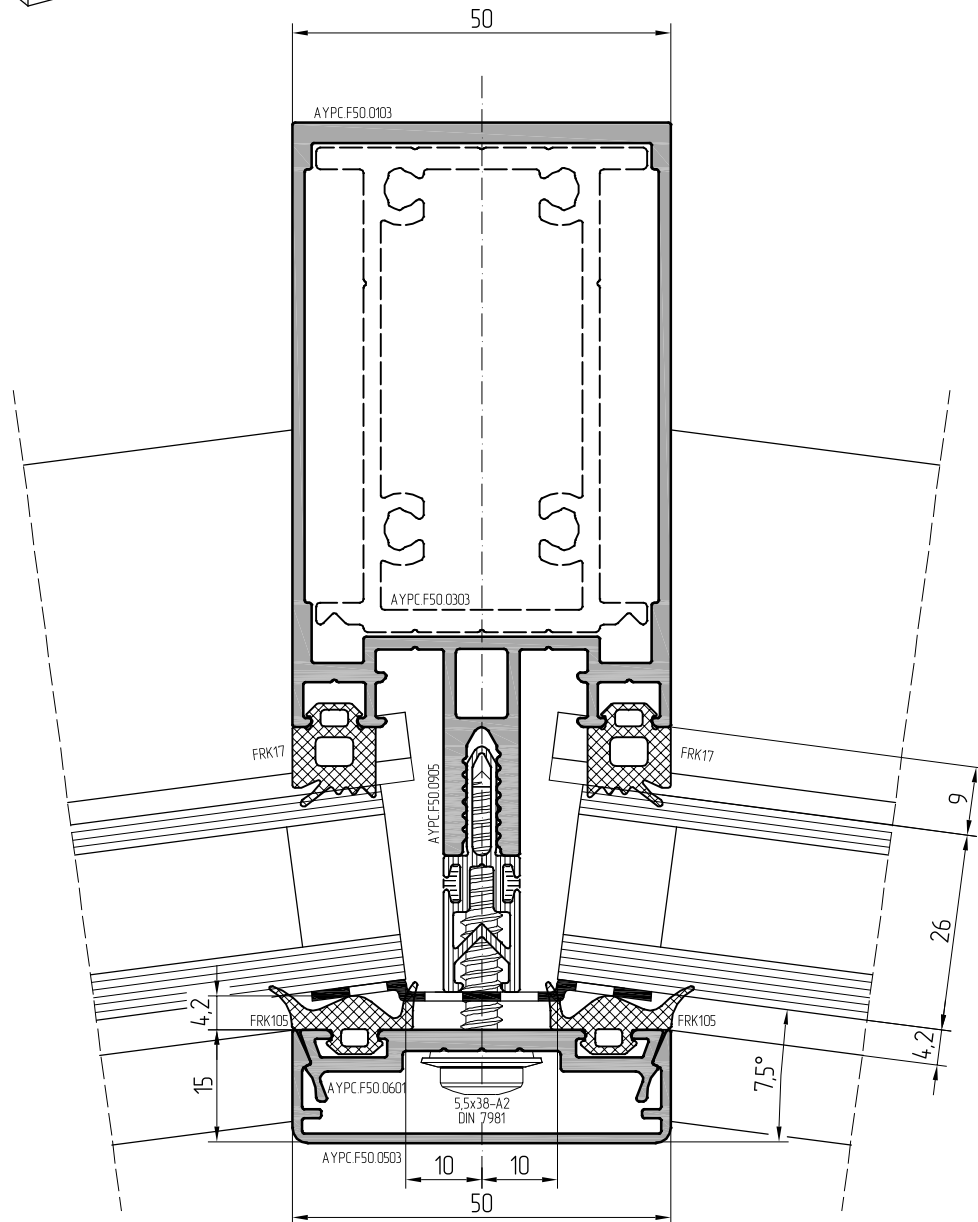
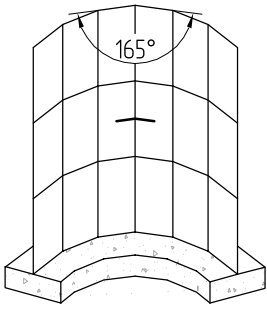

Option

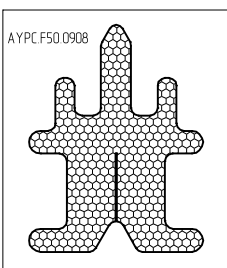

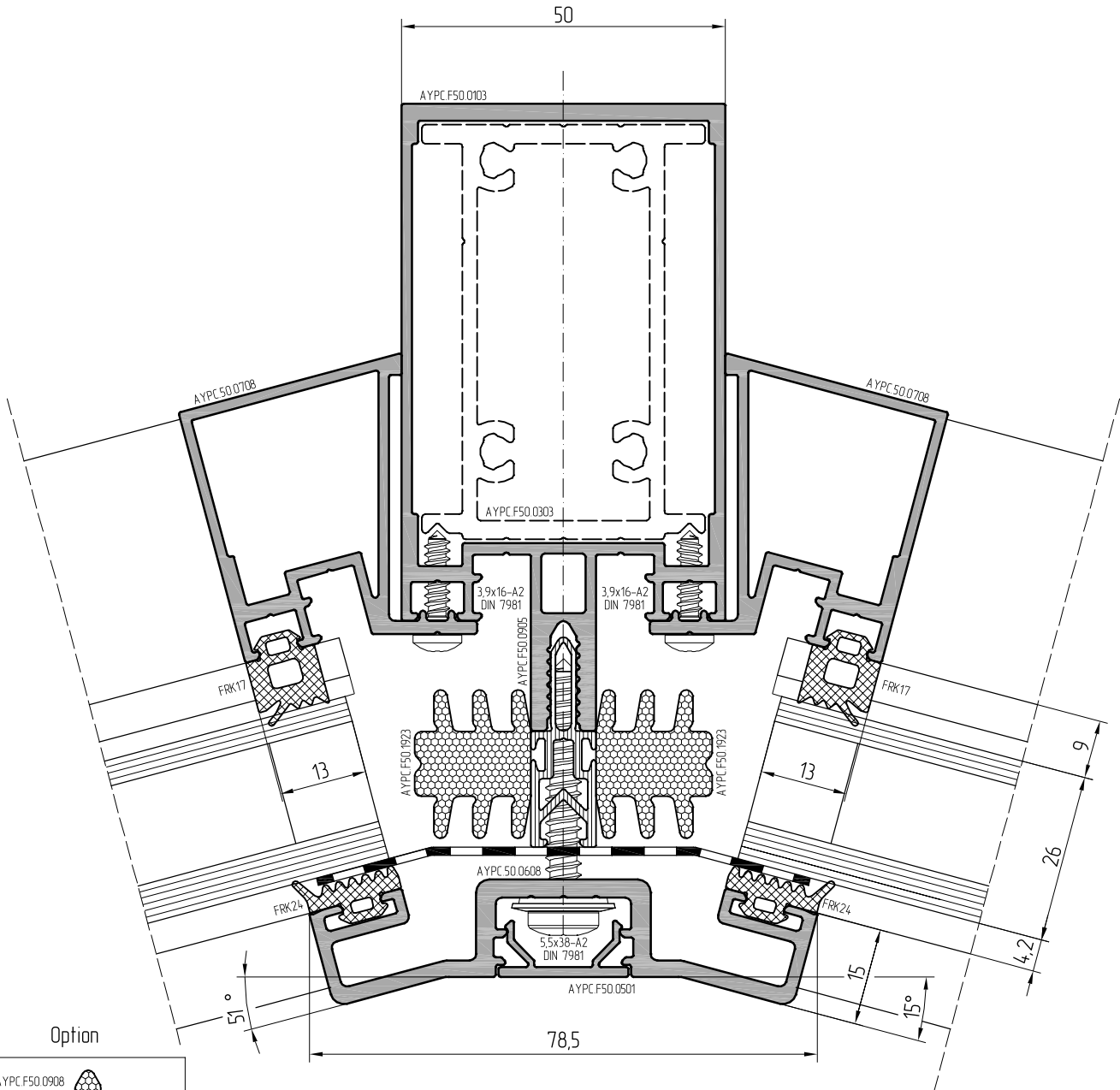
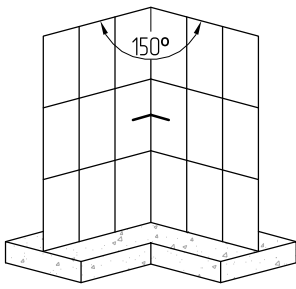

Option

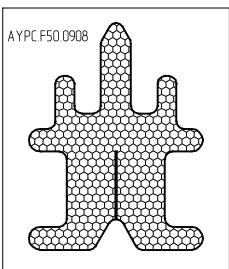

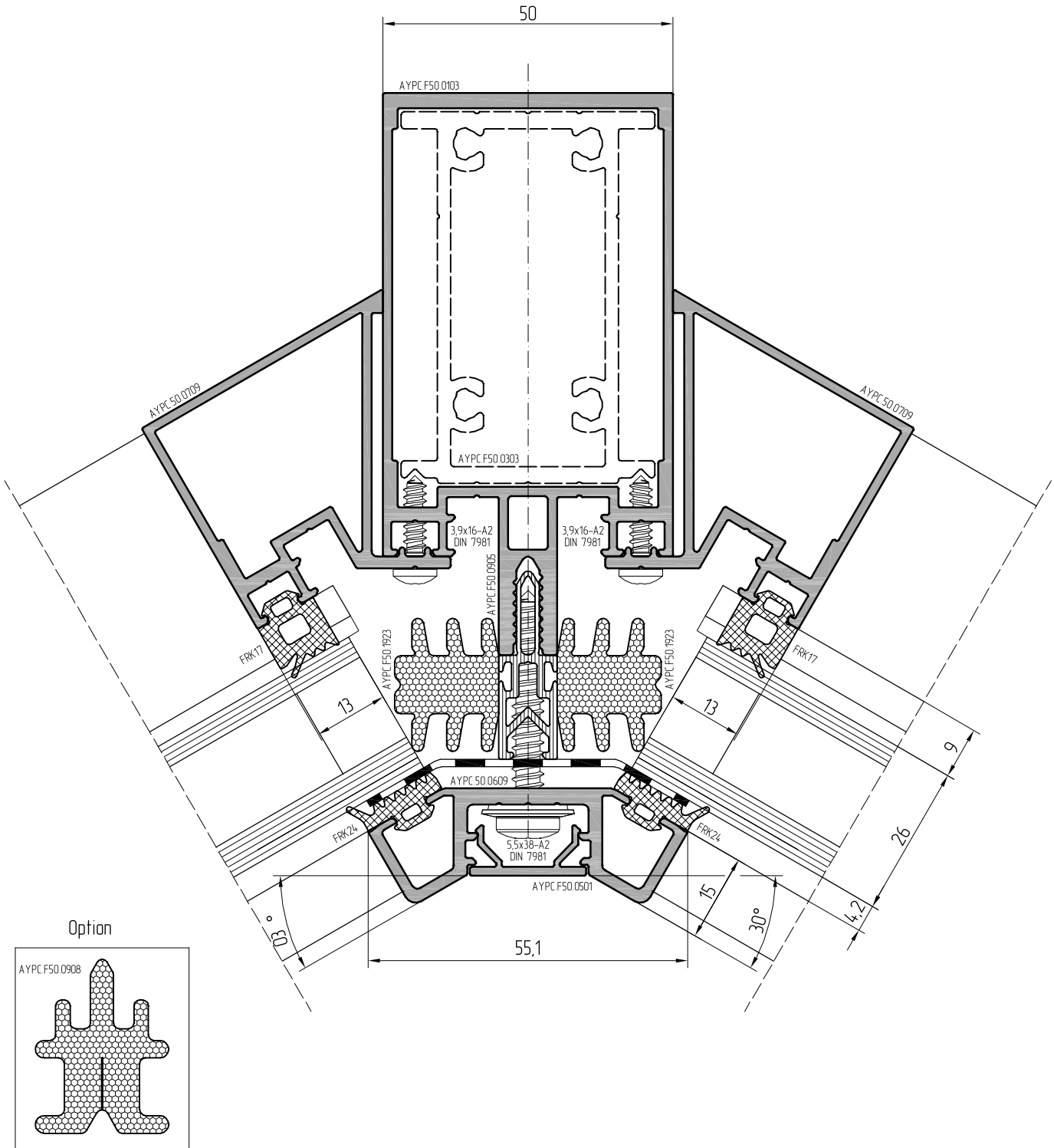
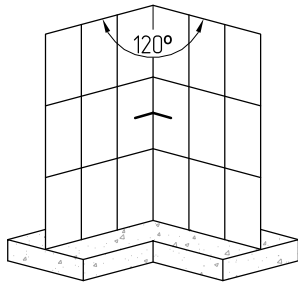



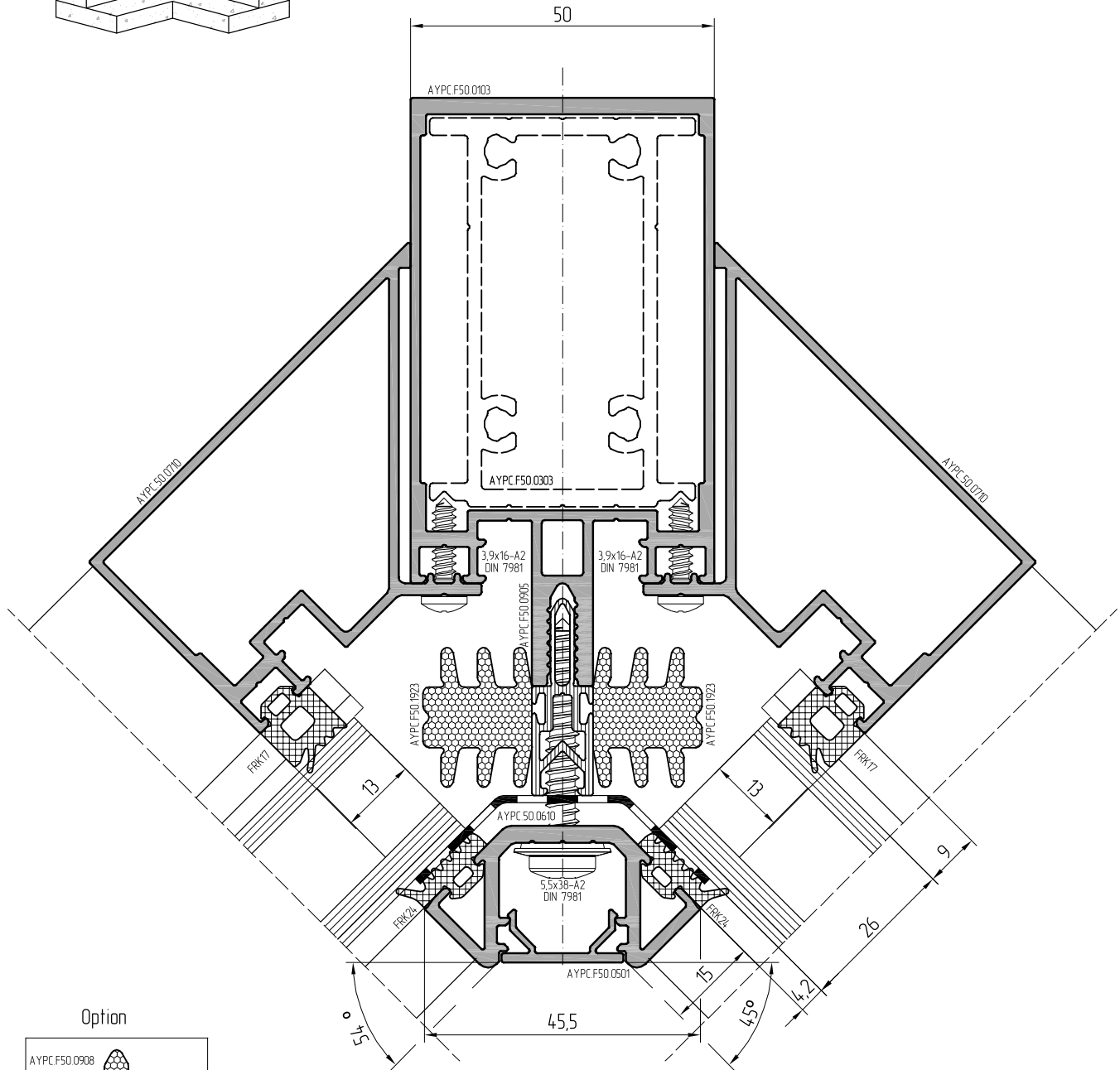
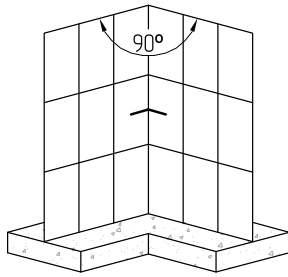

Option

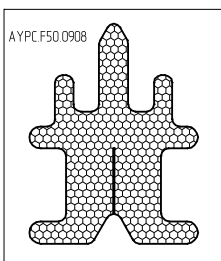

- 01
- 02
- 03
- 04
- 05
- 06
- 07
- 08
- 09
- 10
- 11
- 12
- 13

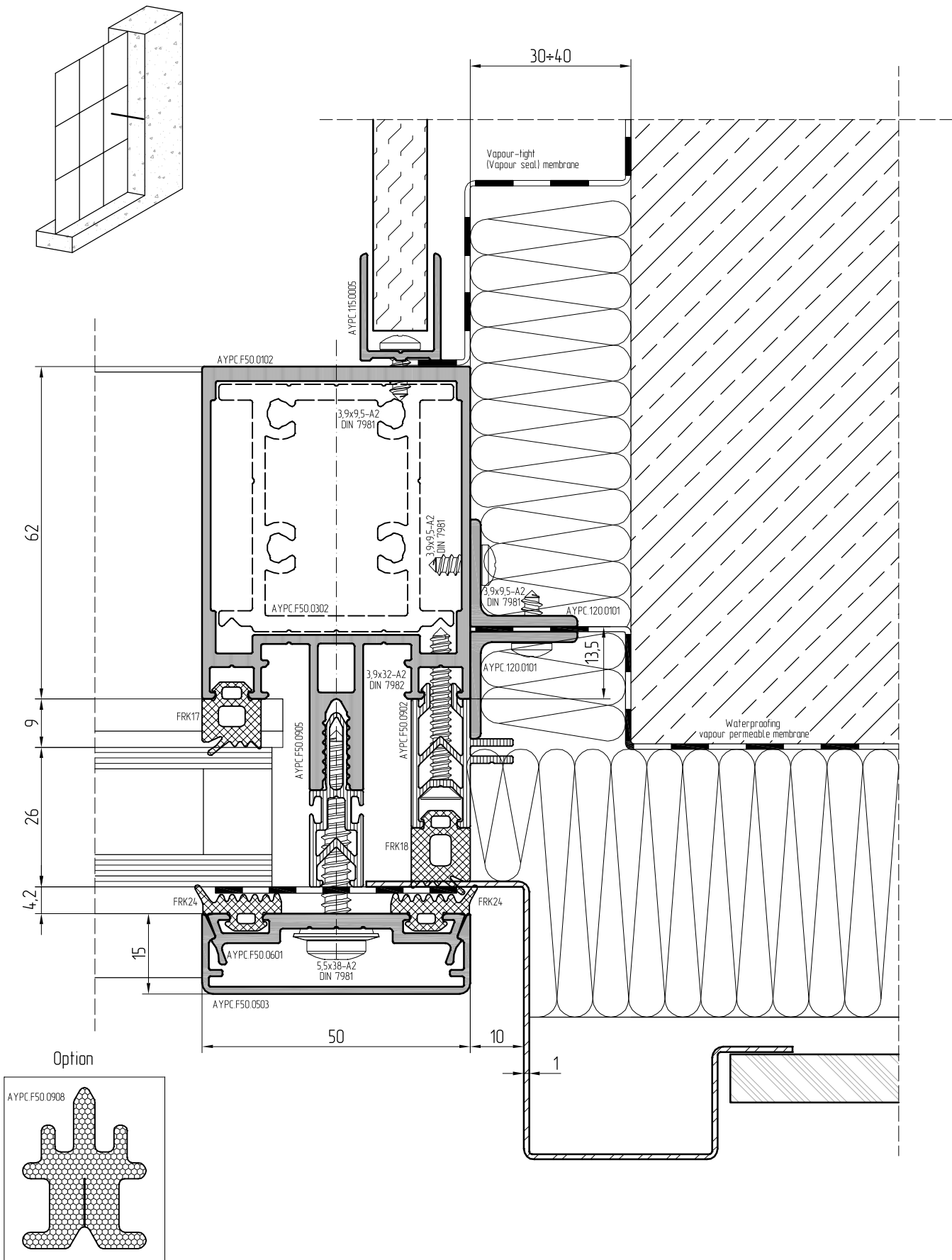

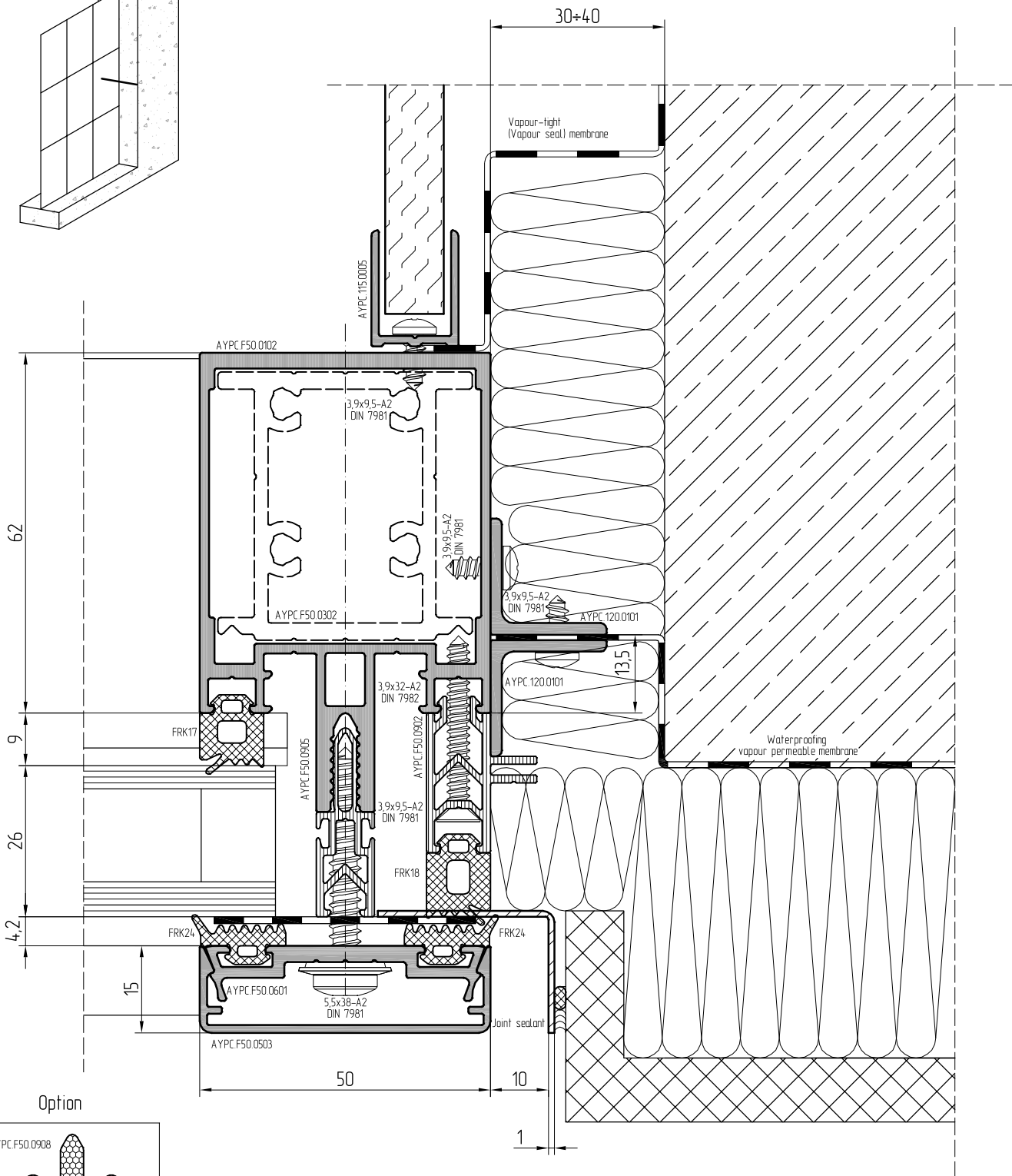
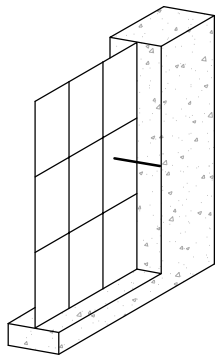

Option

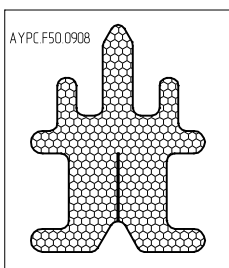

- 01
- 02
- 03
- 04
- 05
- 06
- 07
- 08
- 09
- 10
- 11
- 12
- 13

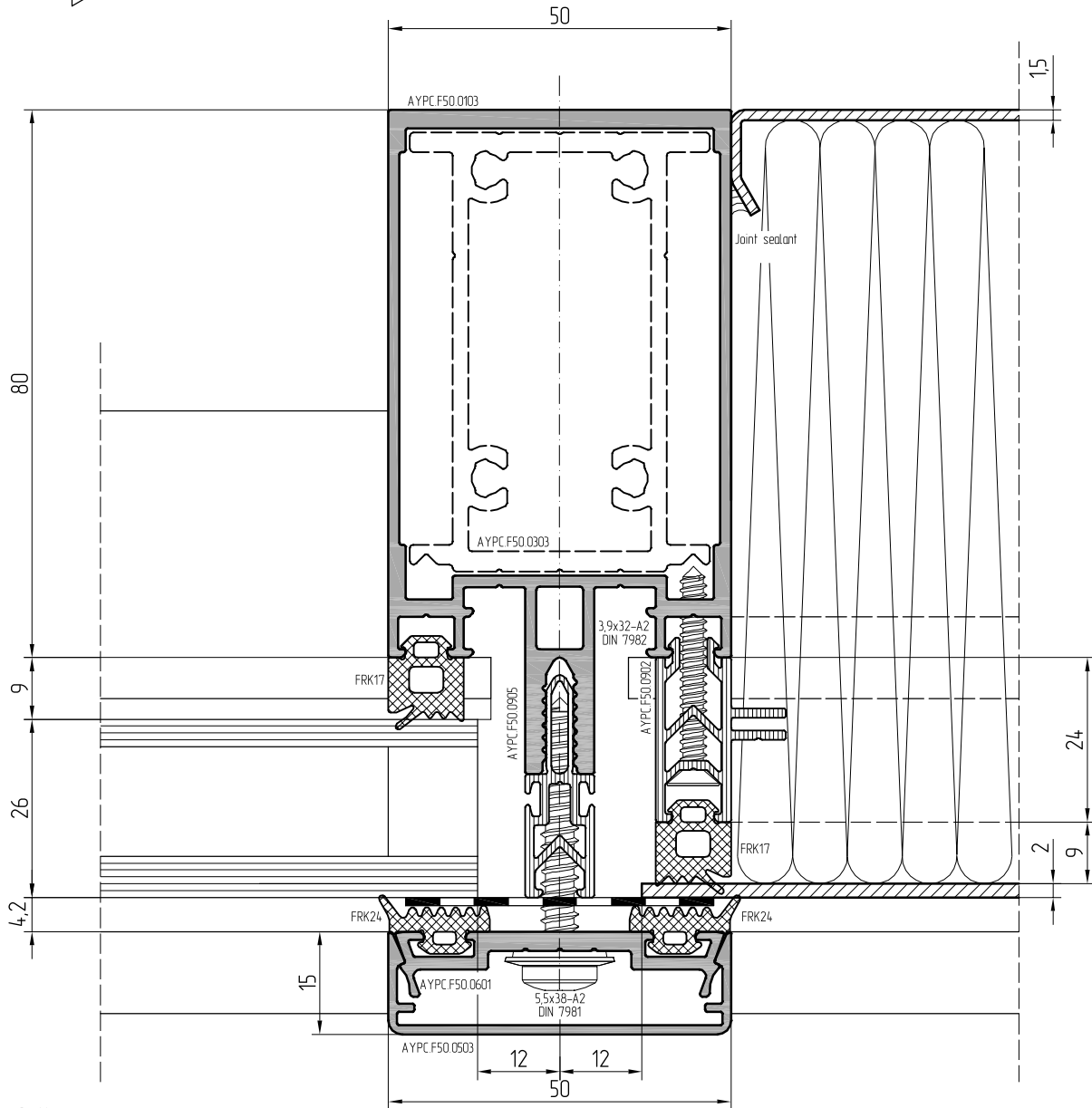
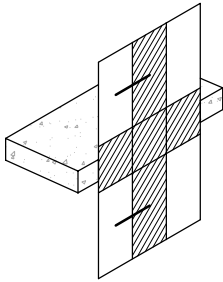

Option

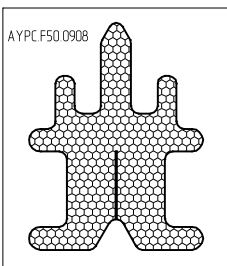

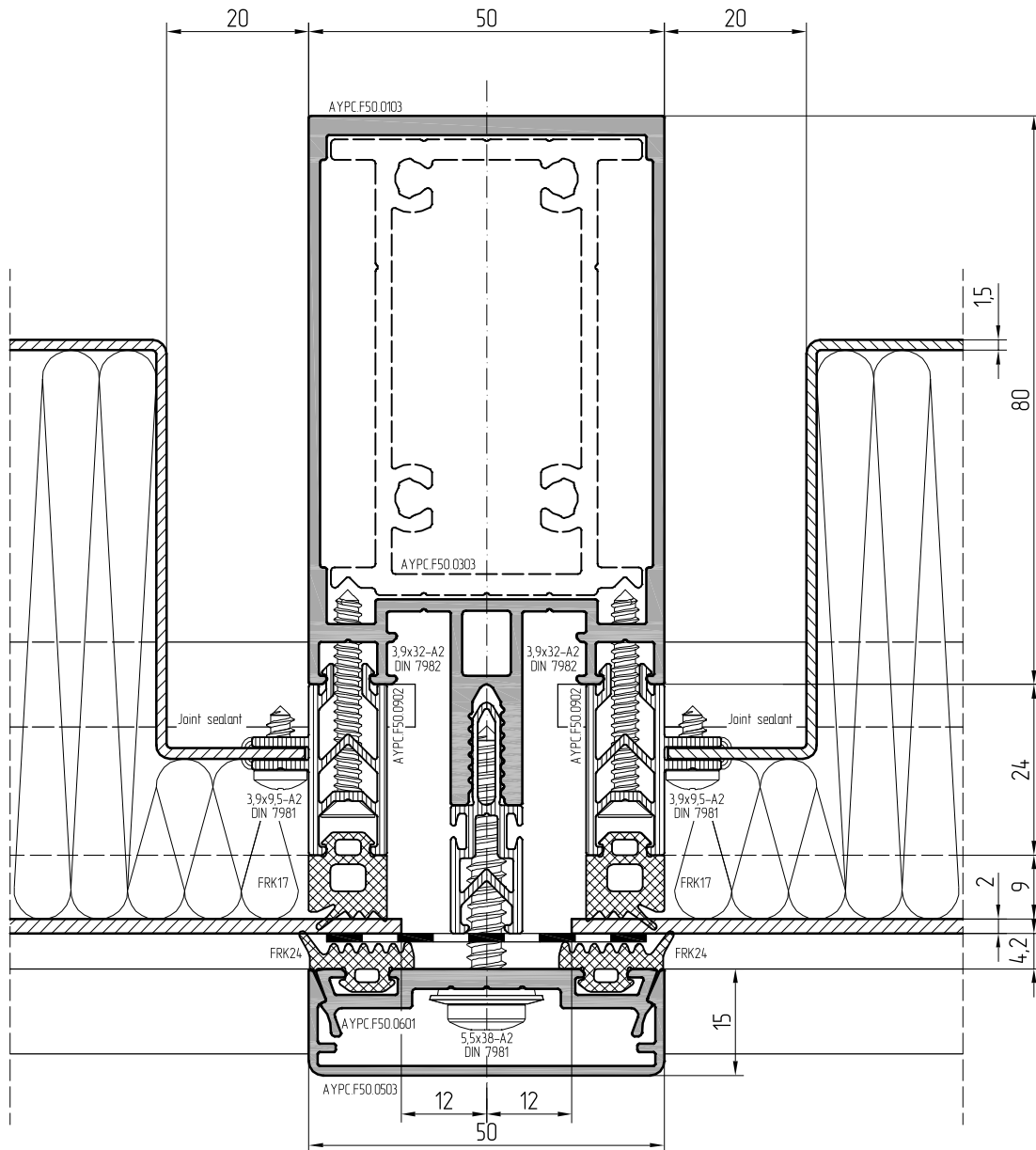
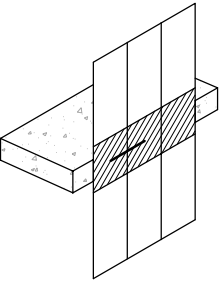

Option

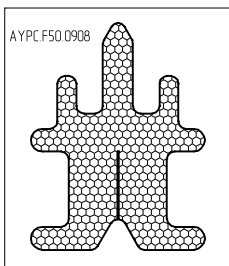

- 01
- 02
- 03
- 04
- 05
- 06
- 07
- 08
- 09
- 10
- 11
- 12
- 13



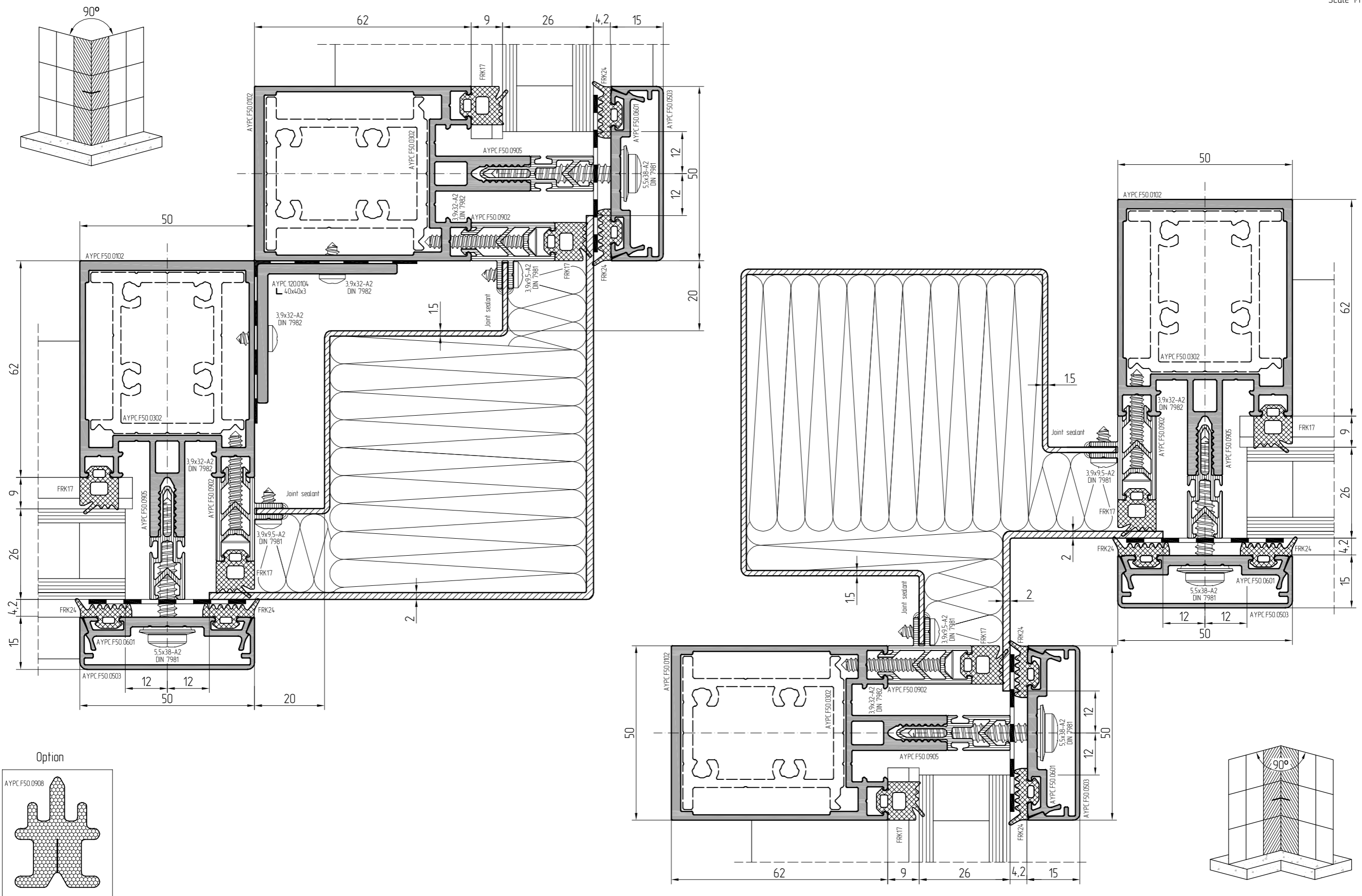





Scale 1:1

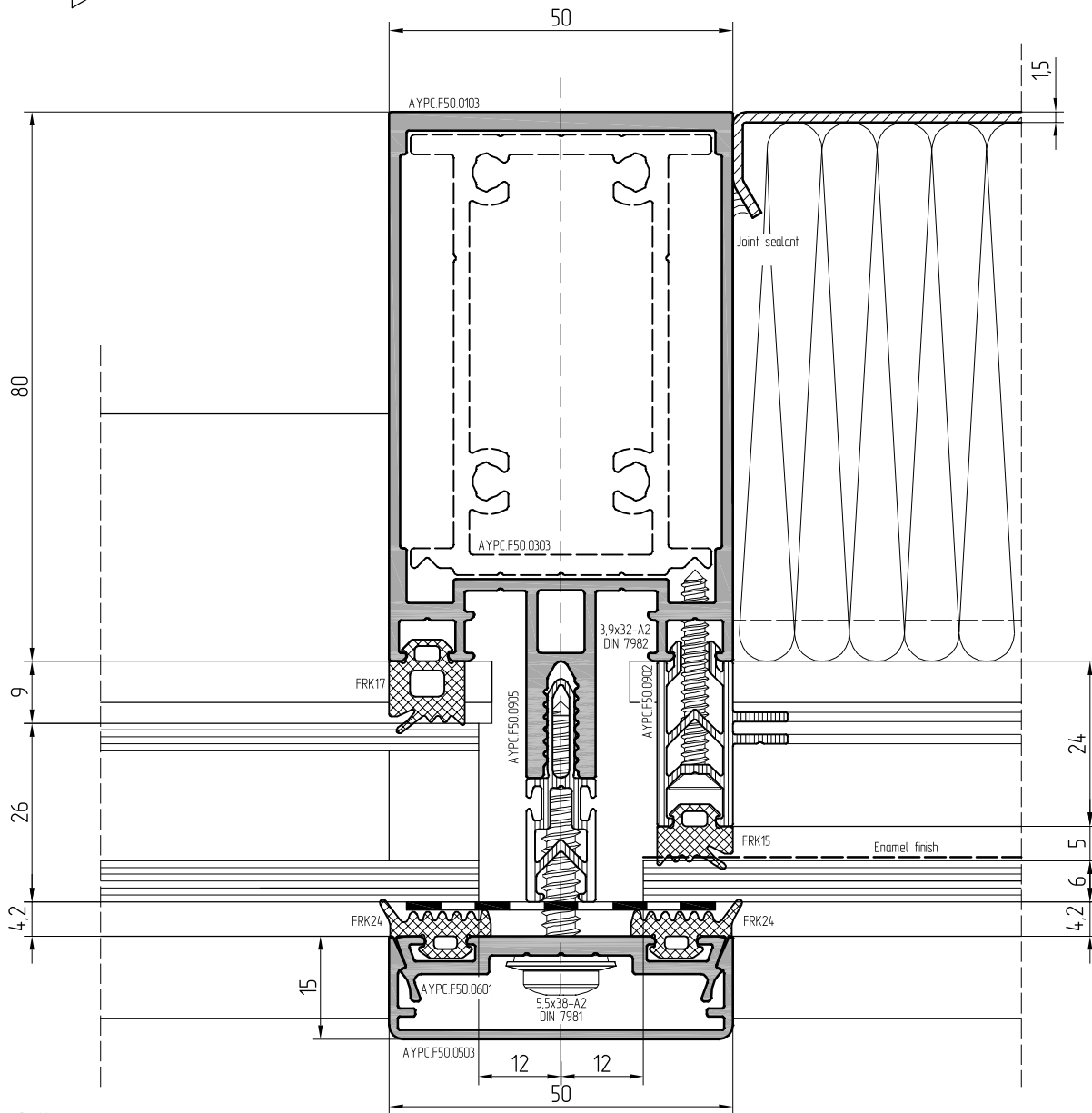
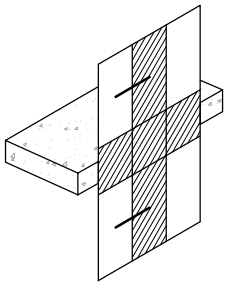

Option

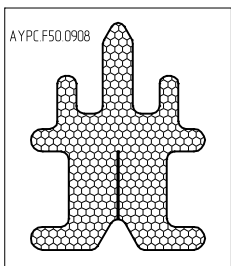

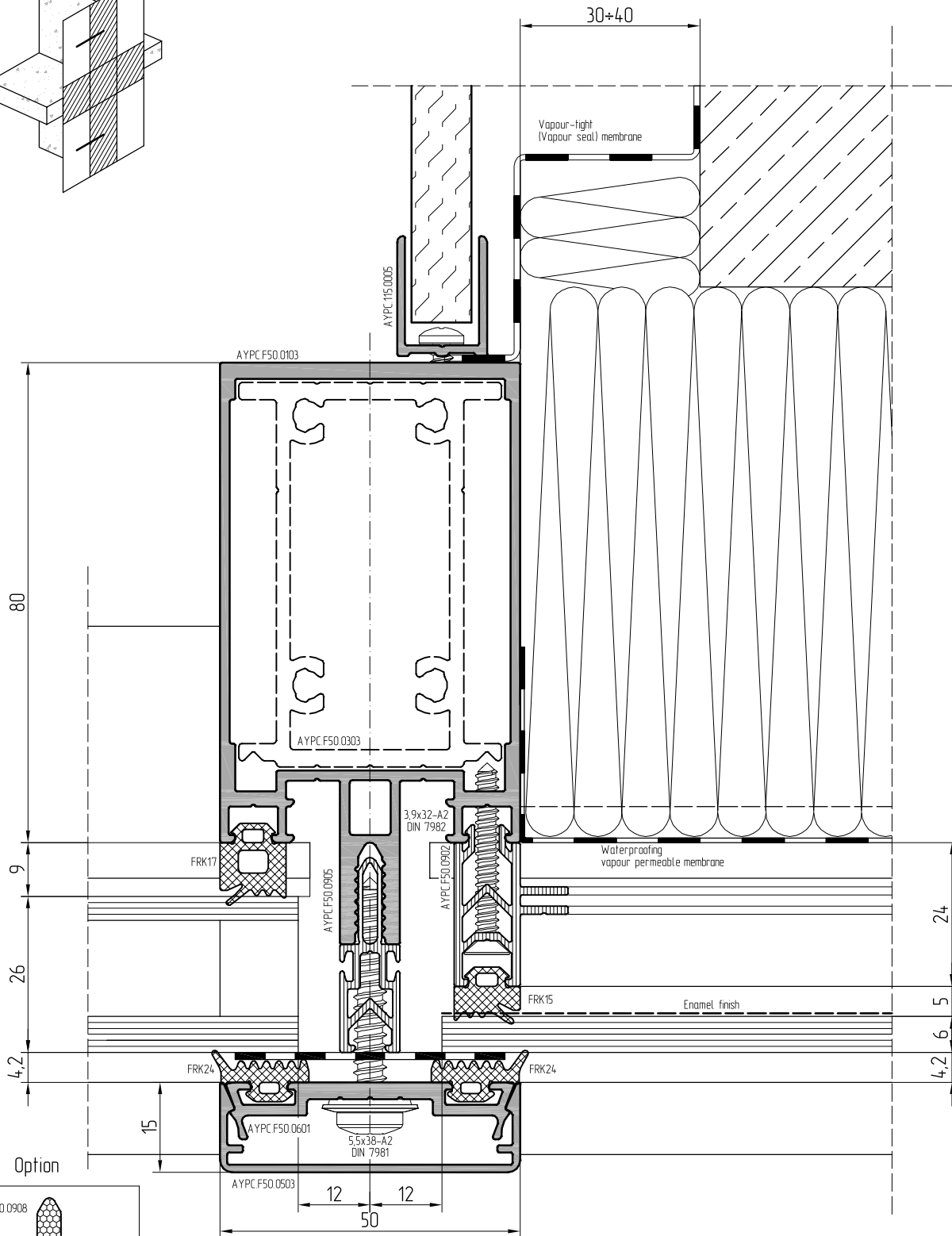
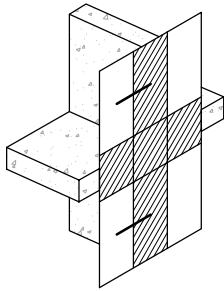

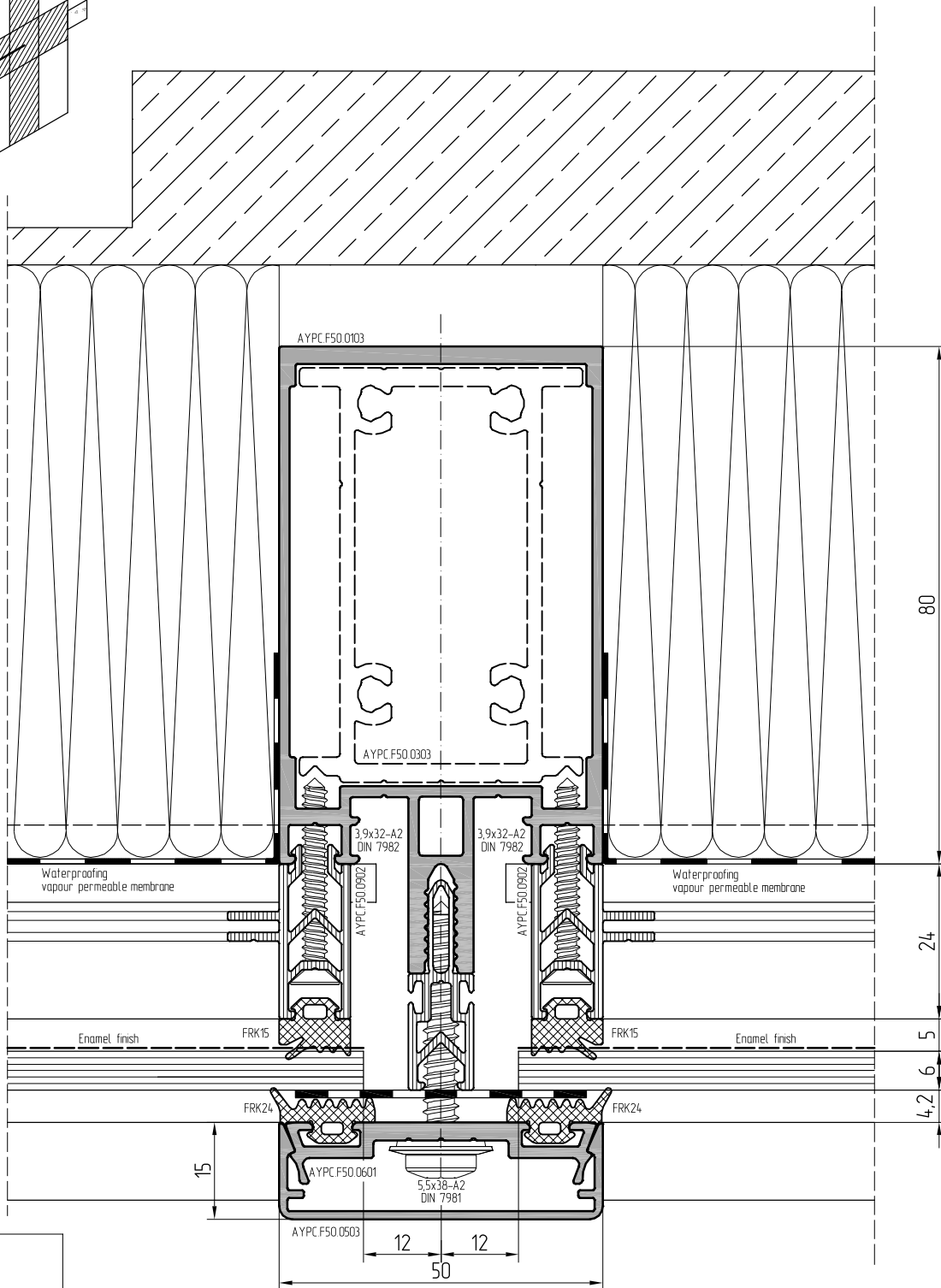
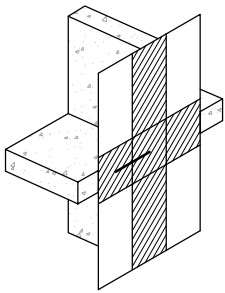

Option

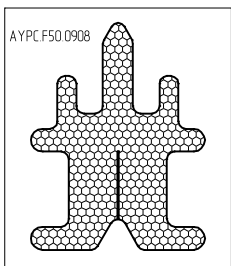

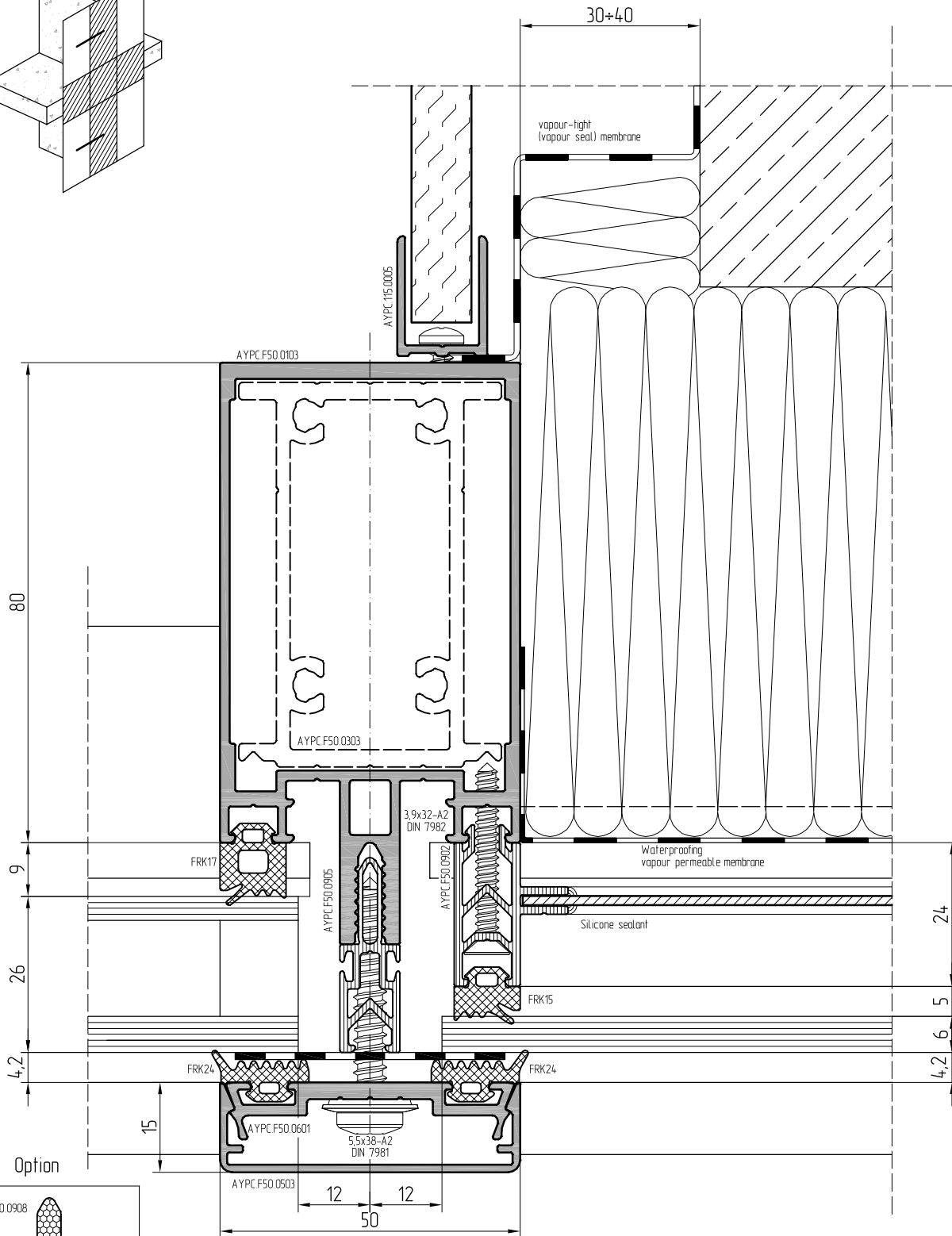
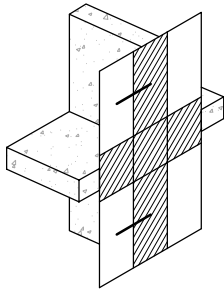

Scale 1:1

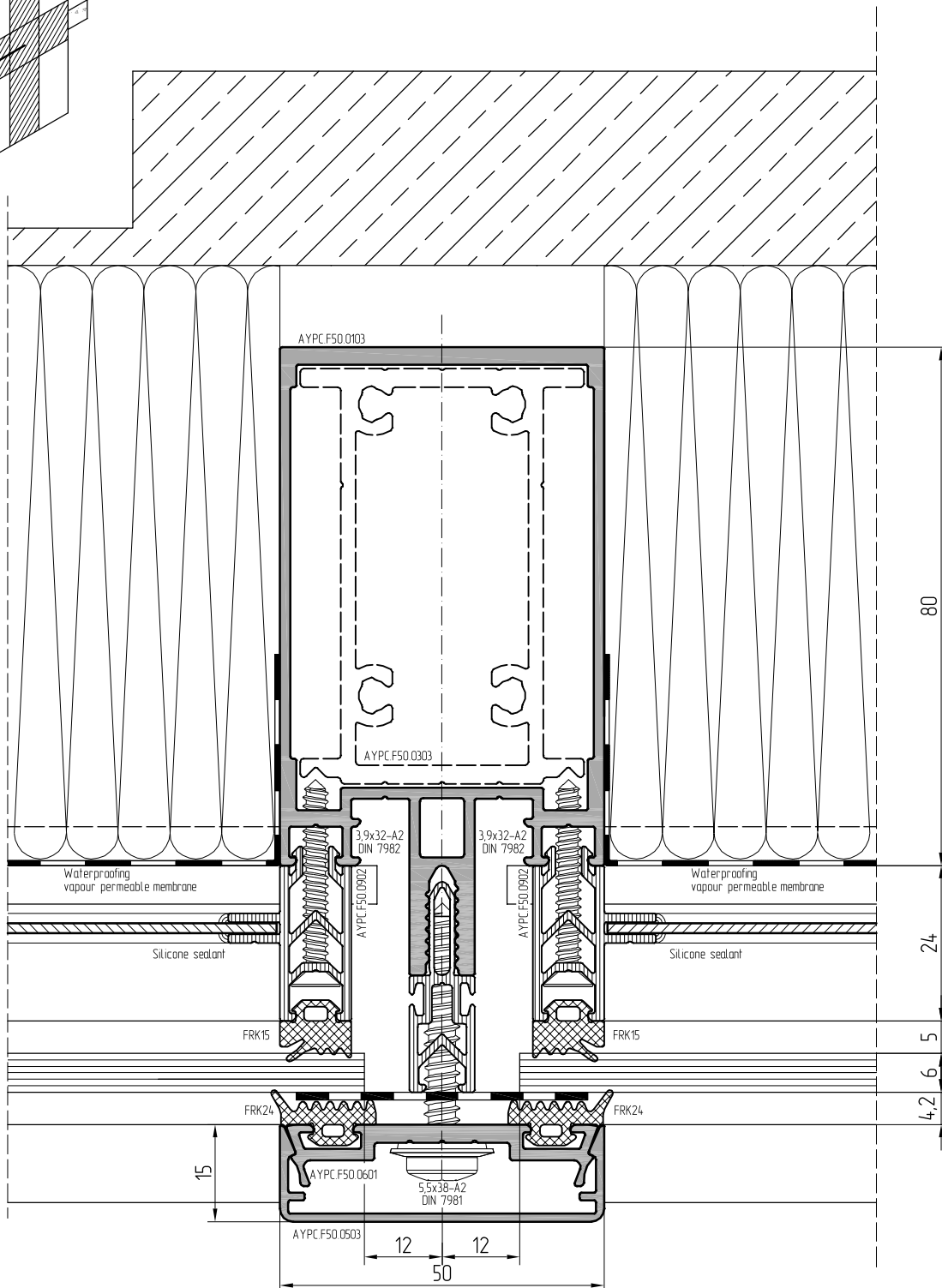
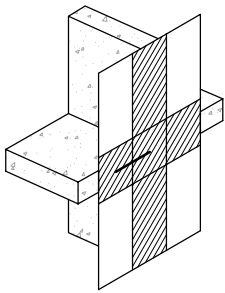



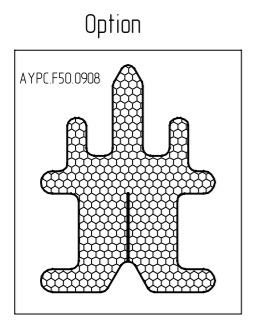
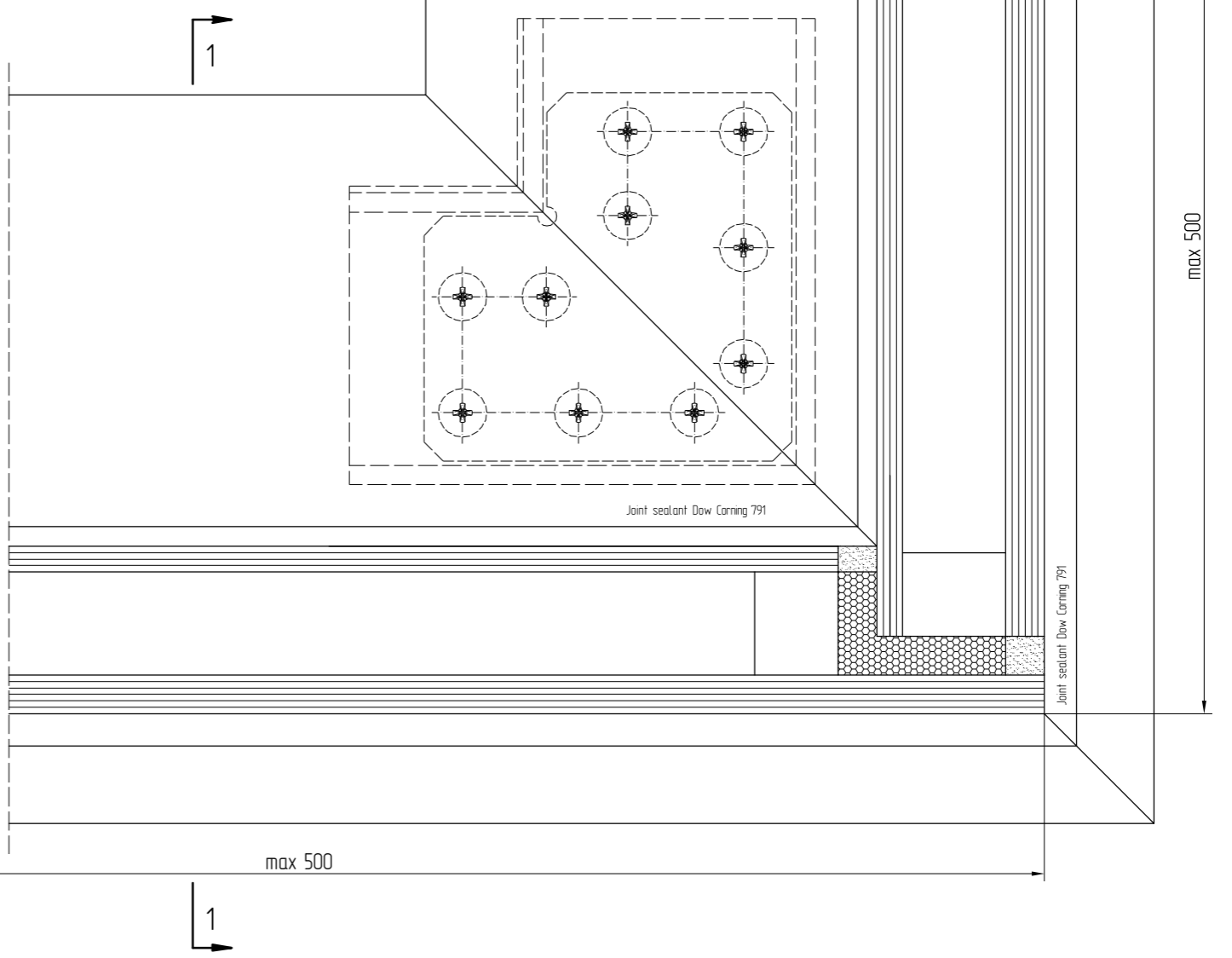
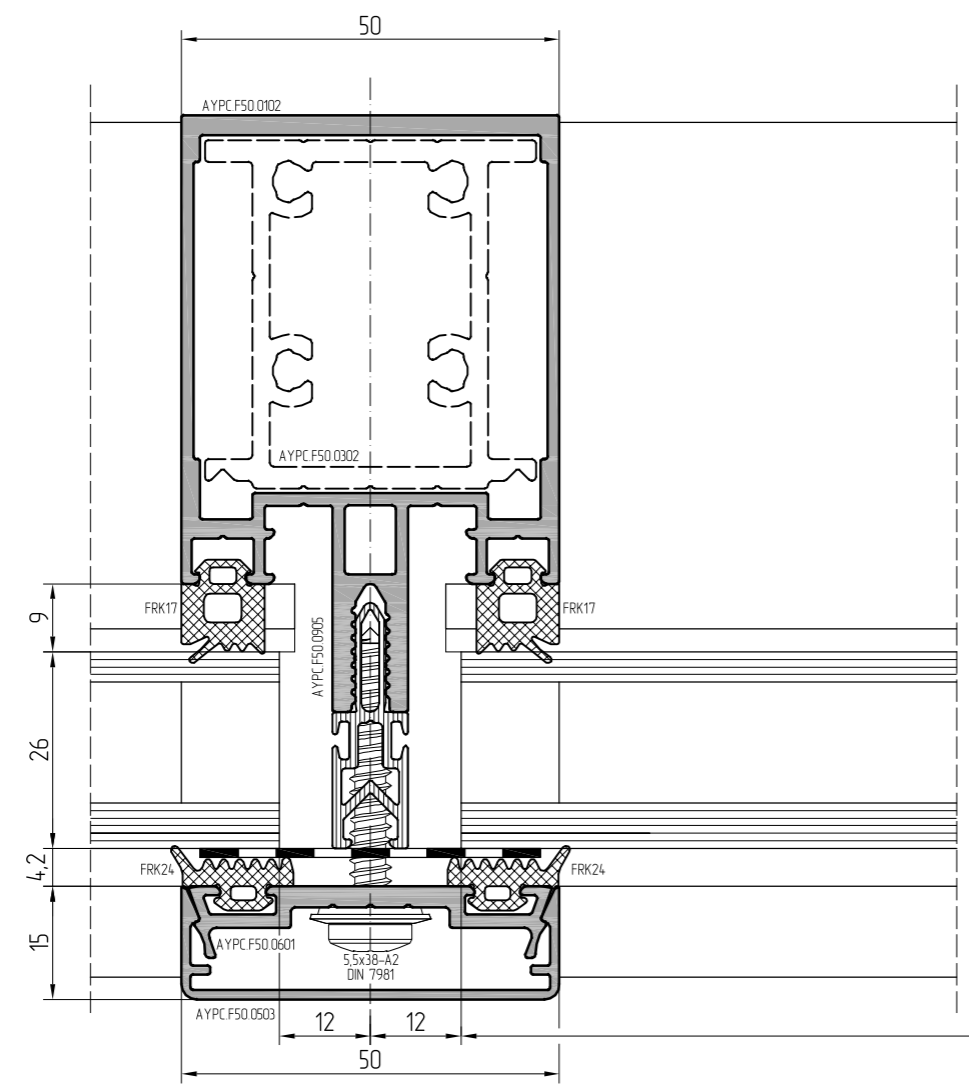
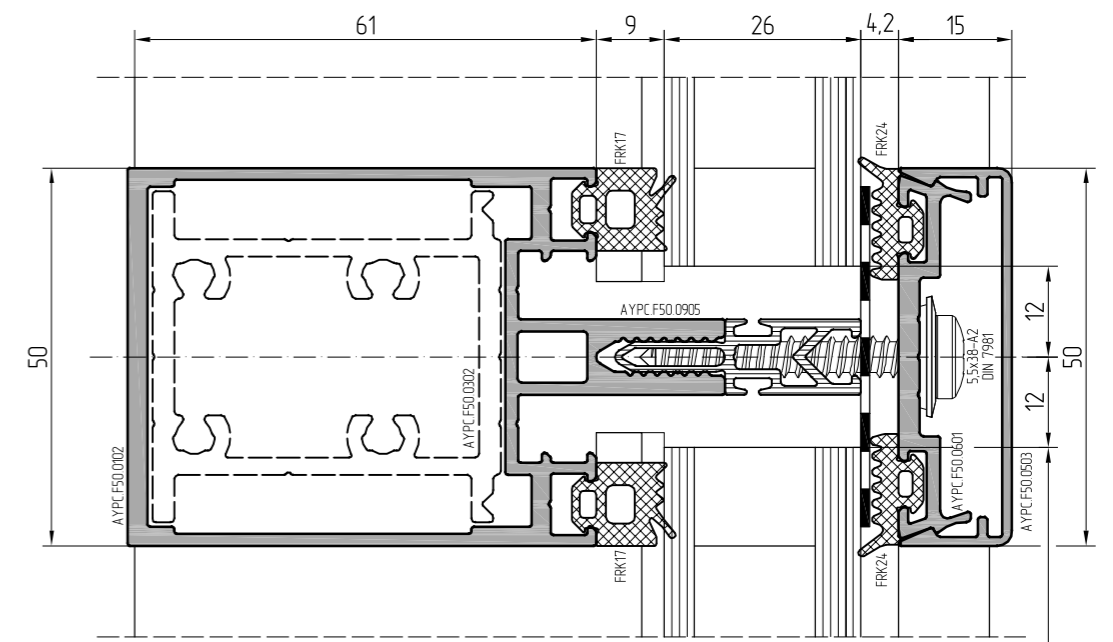
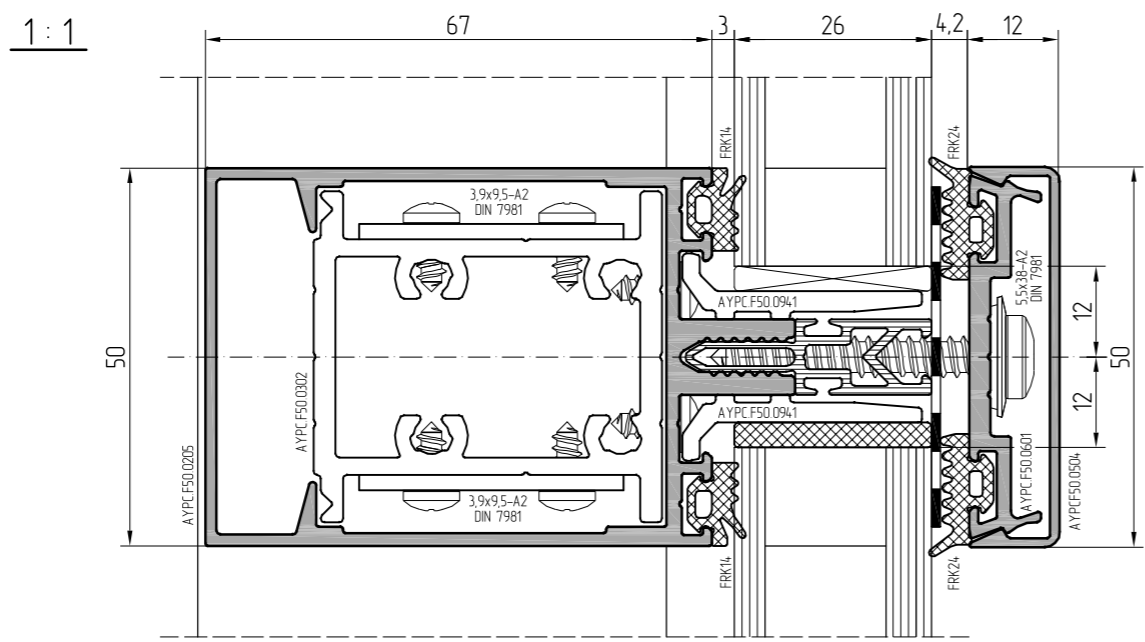
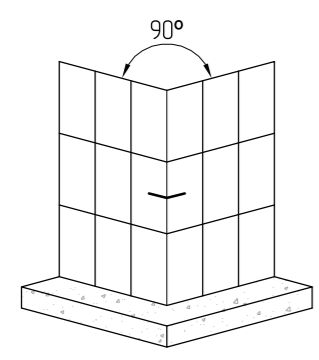

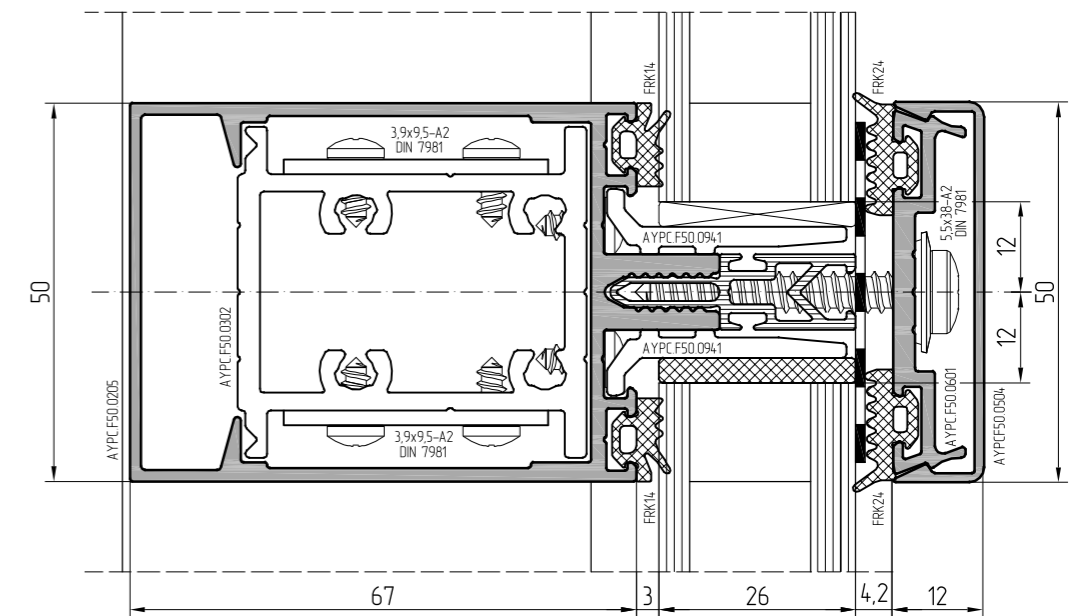
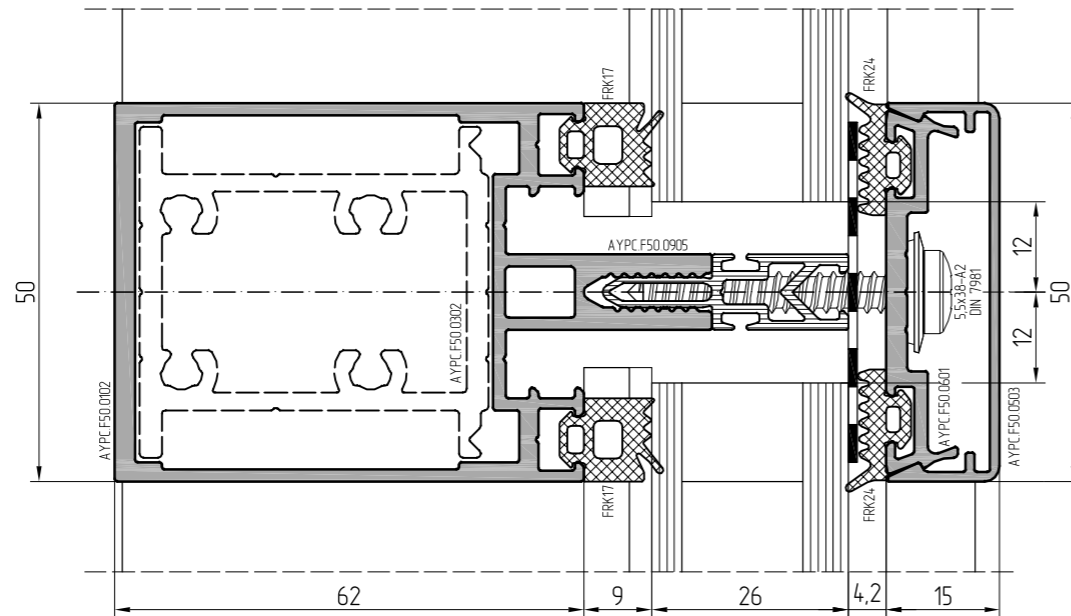
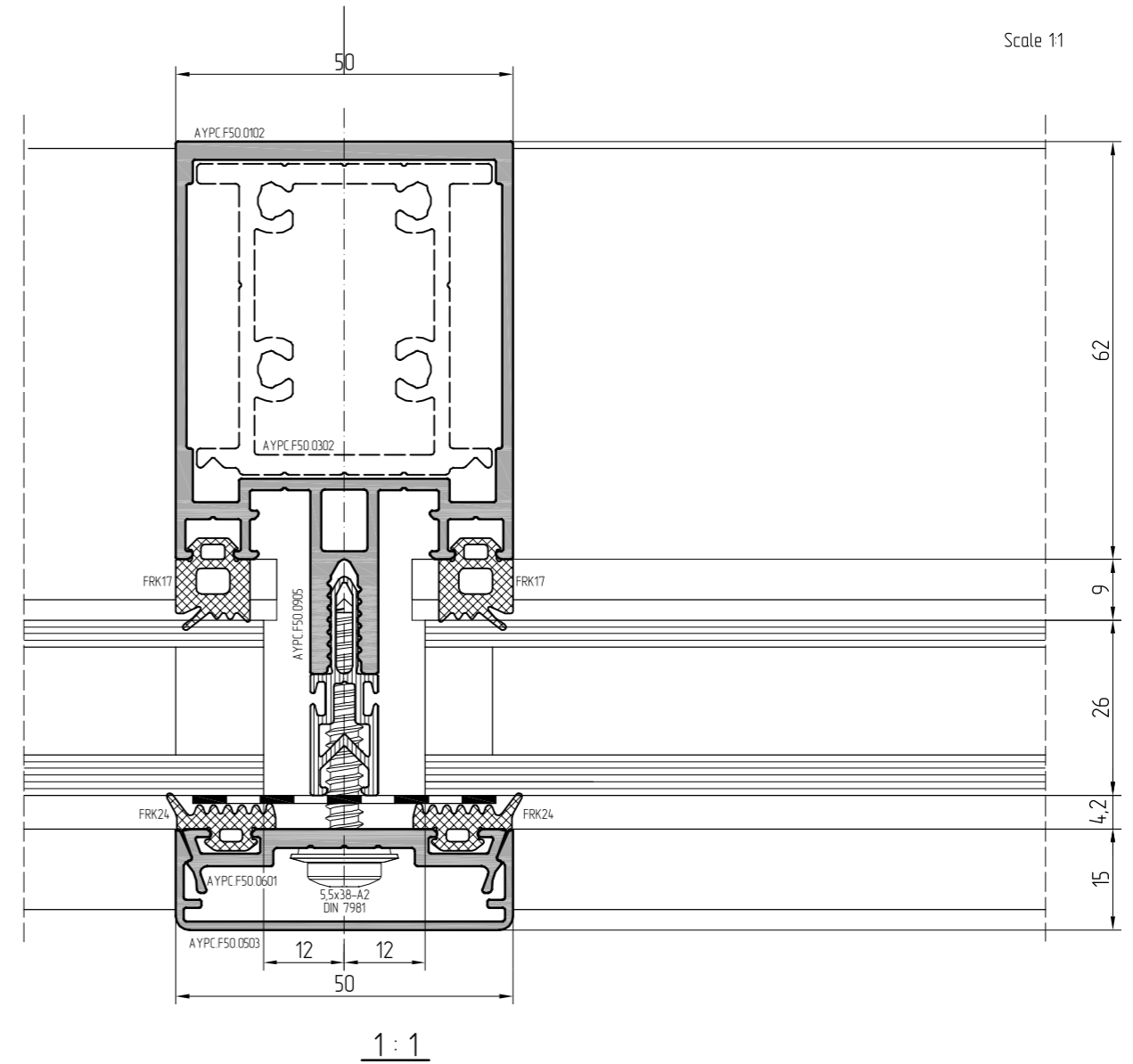
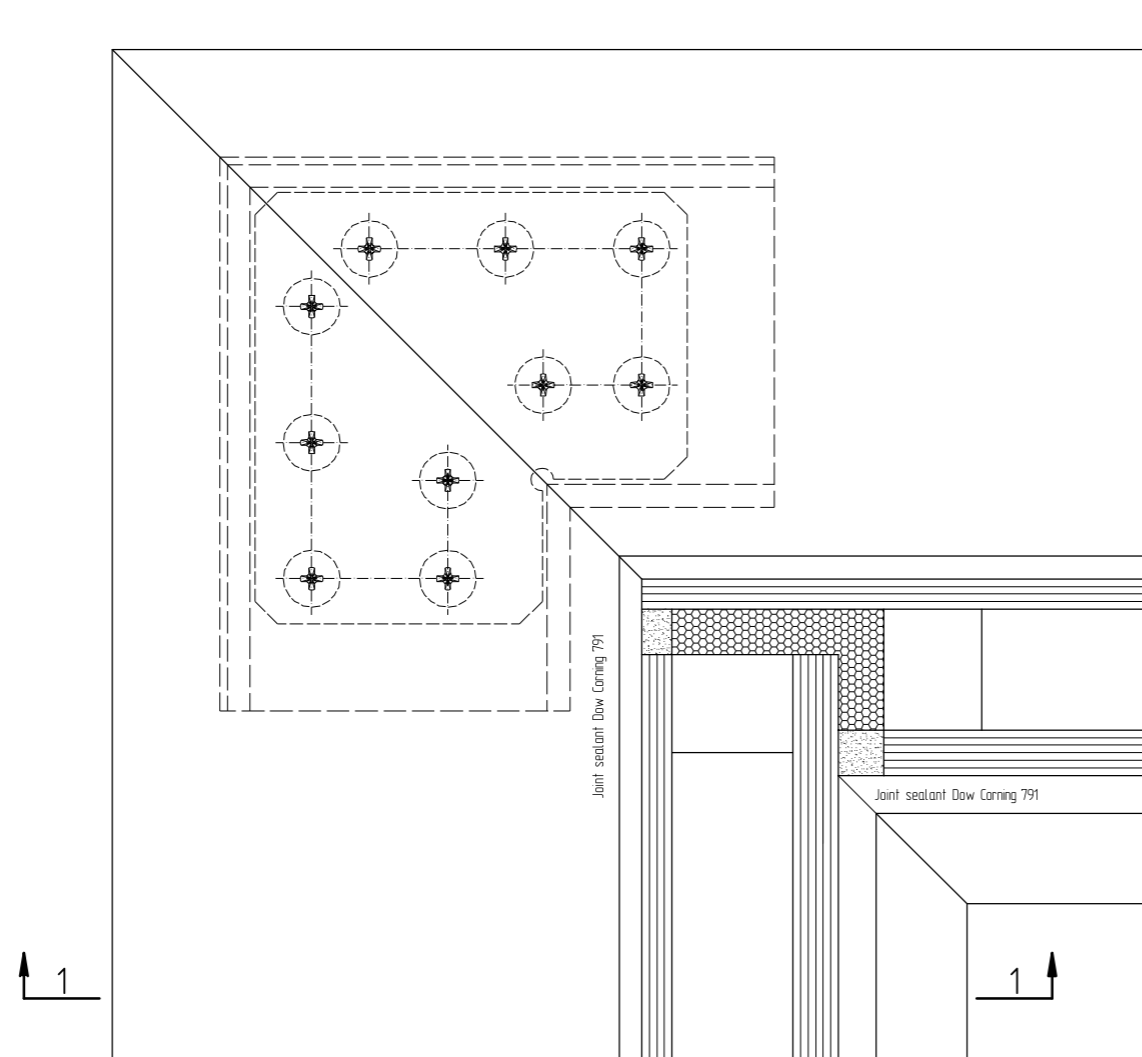
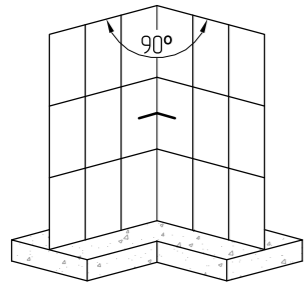

Option

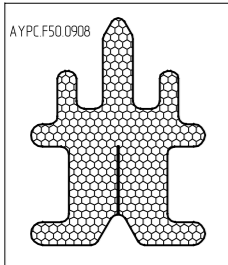



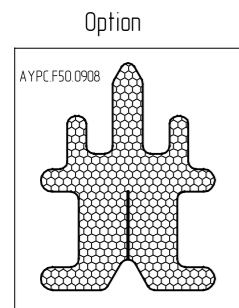
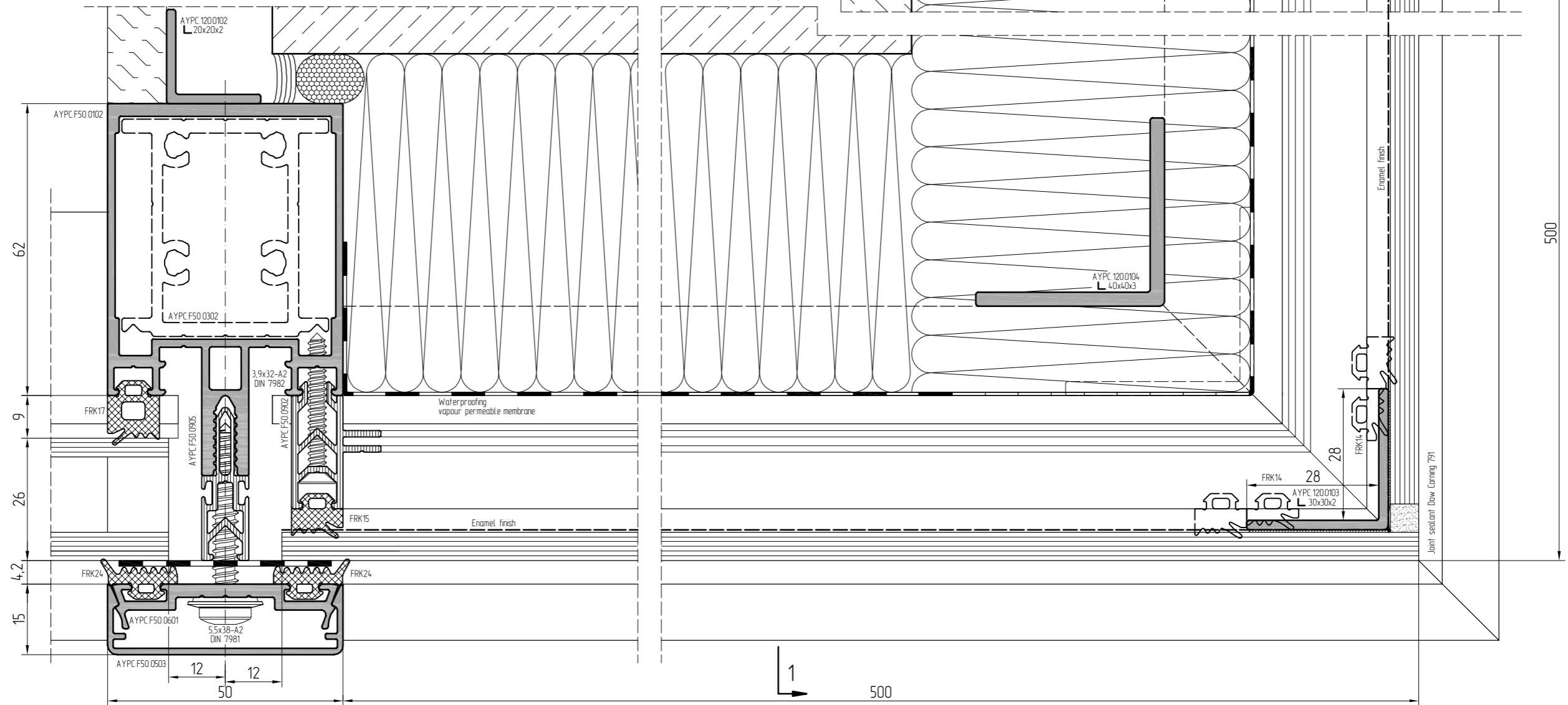
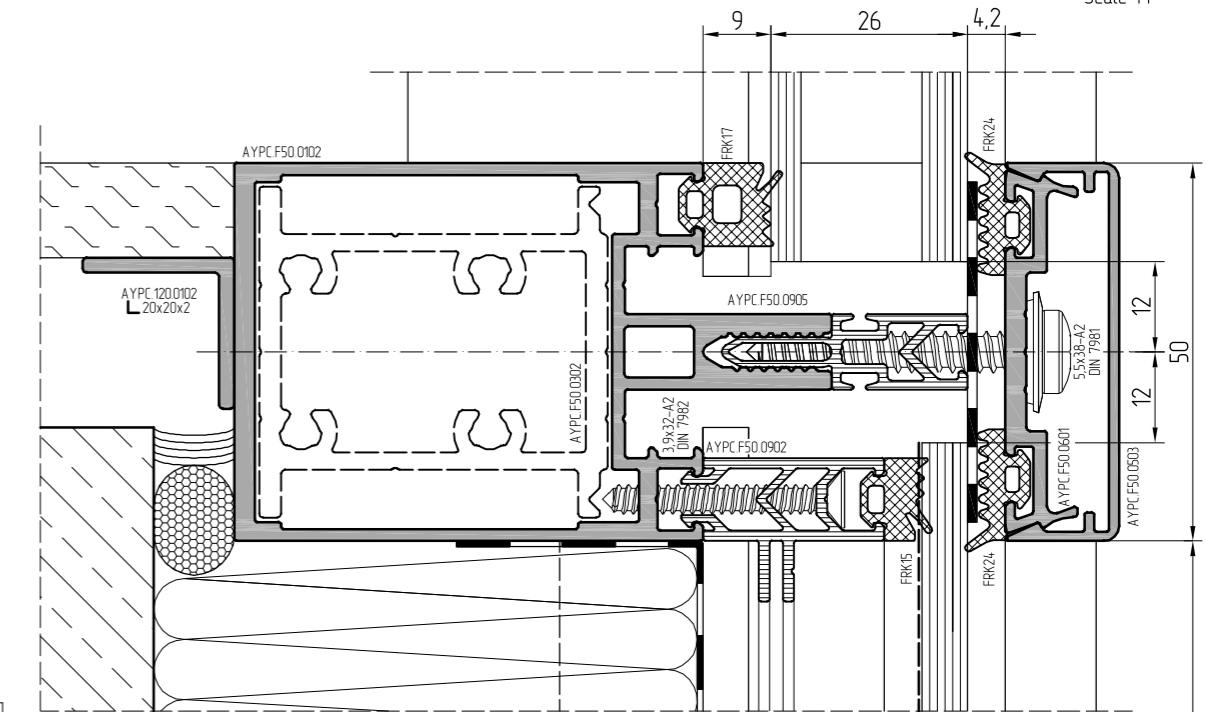
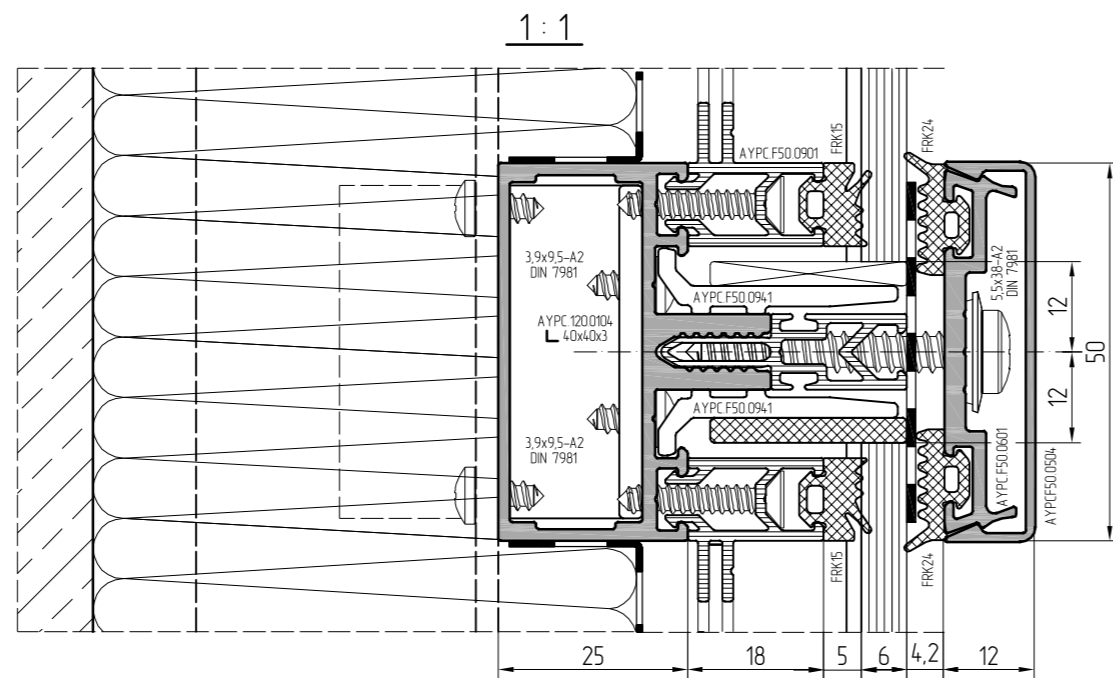
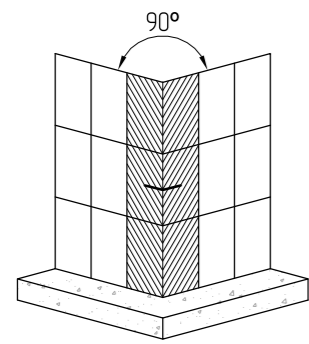

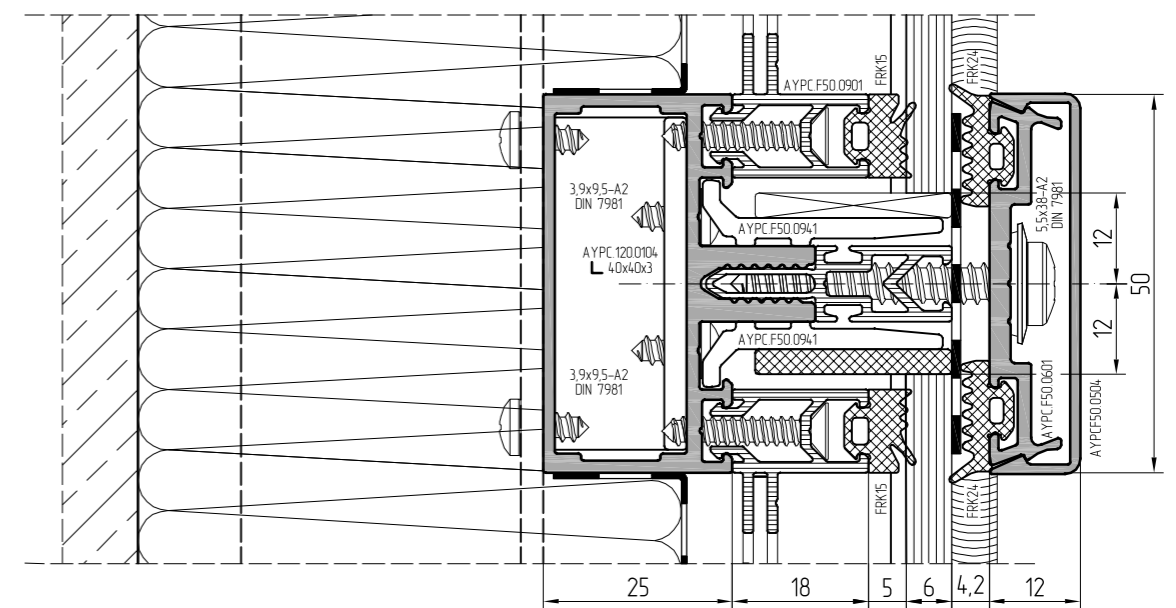
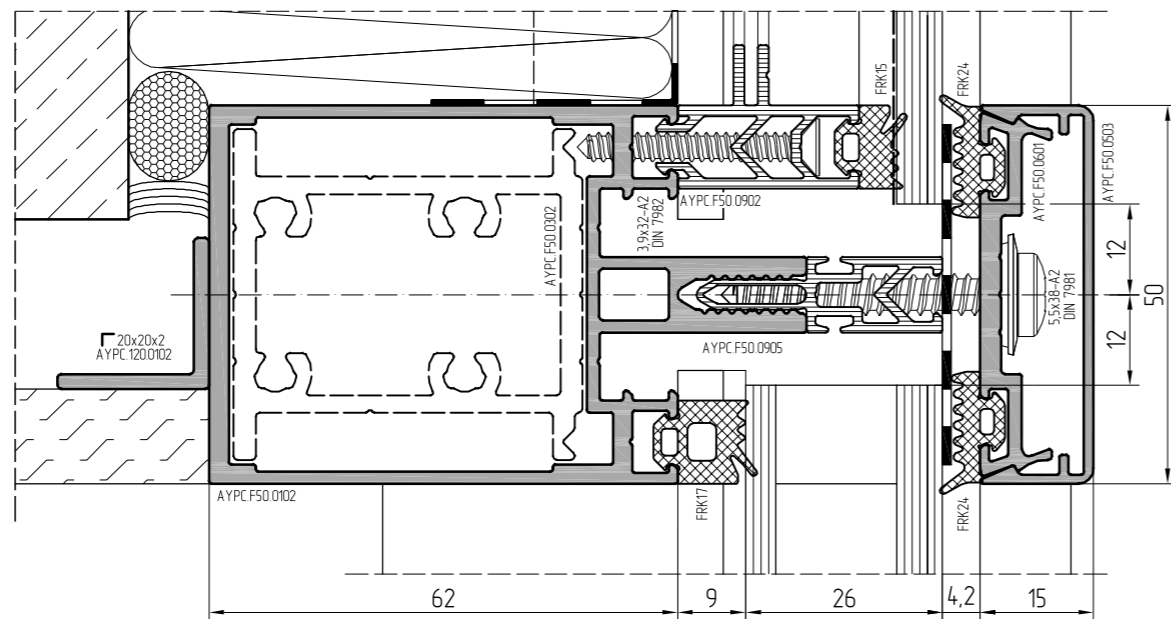
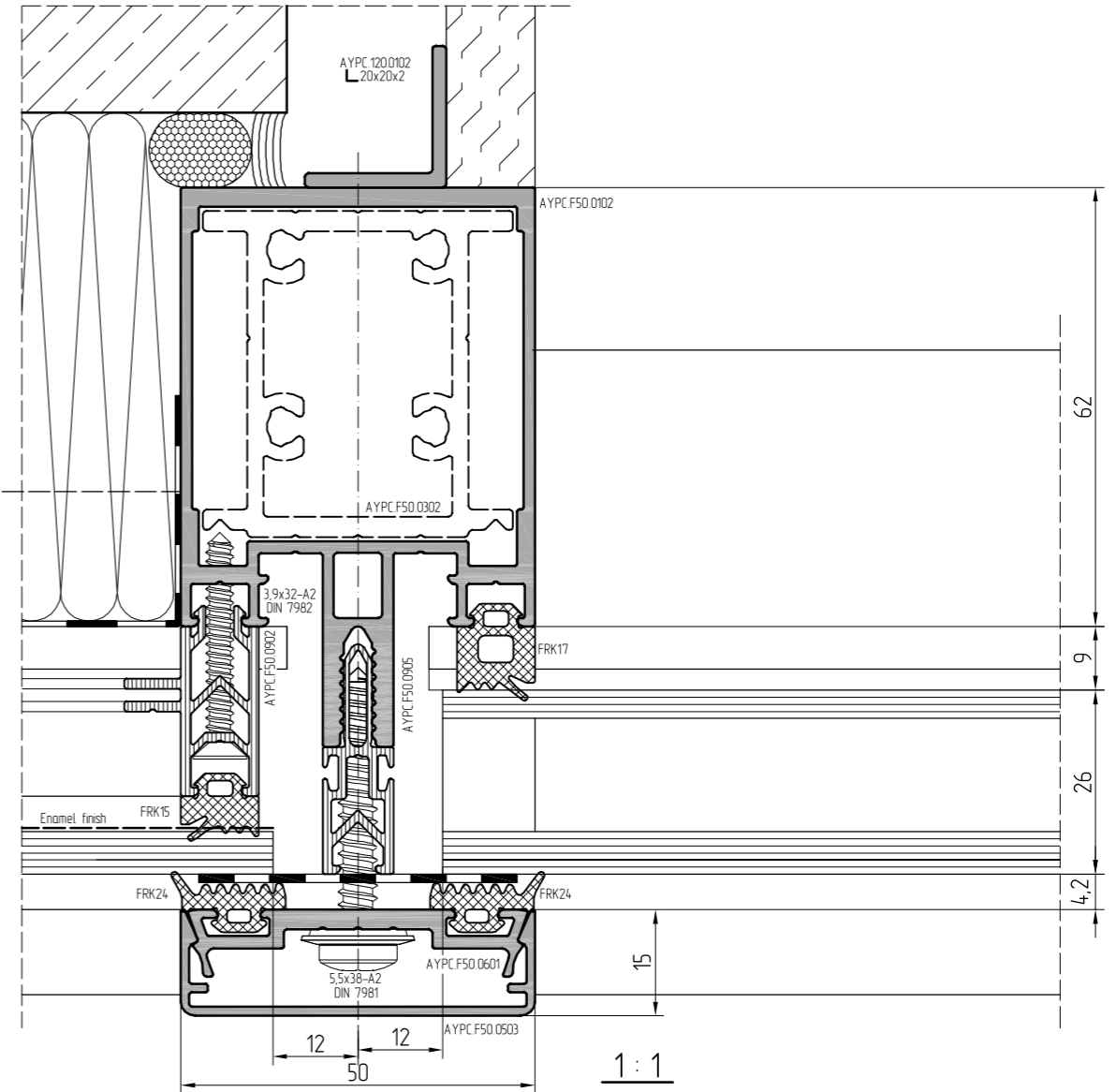
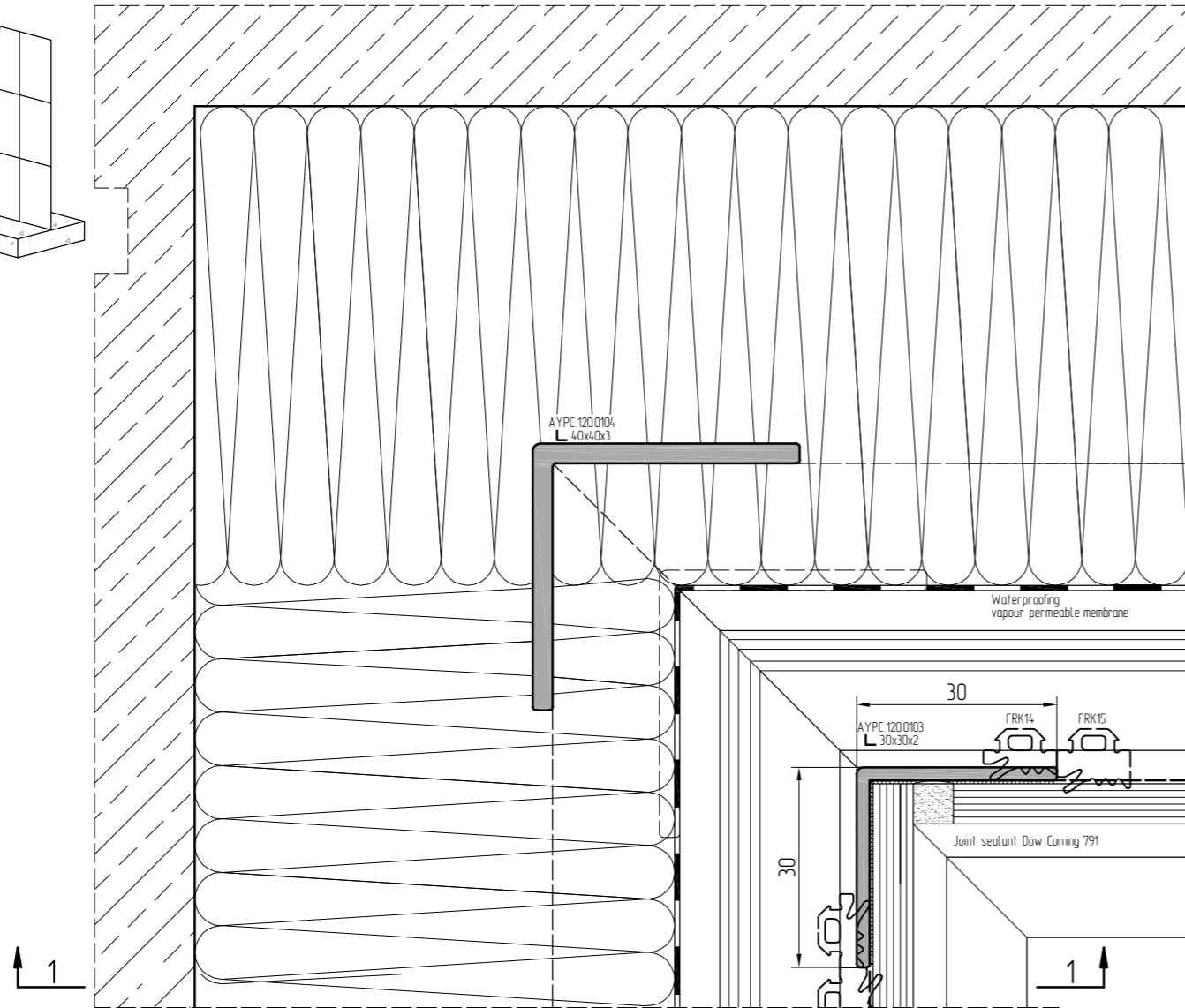
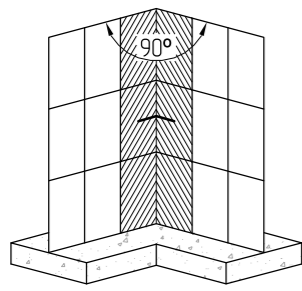

Option

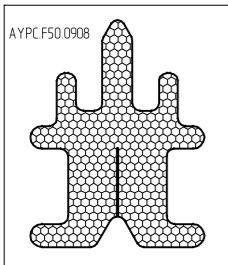

Scale 1:1

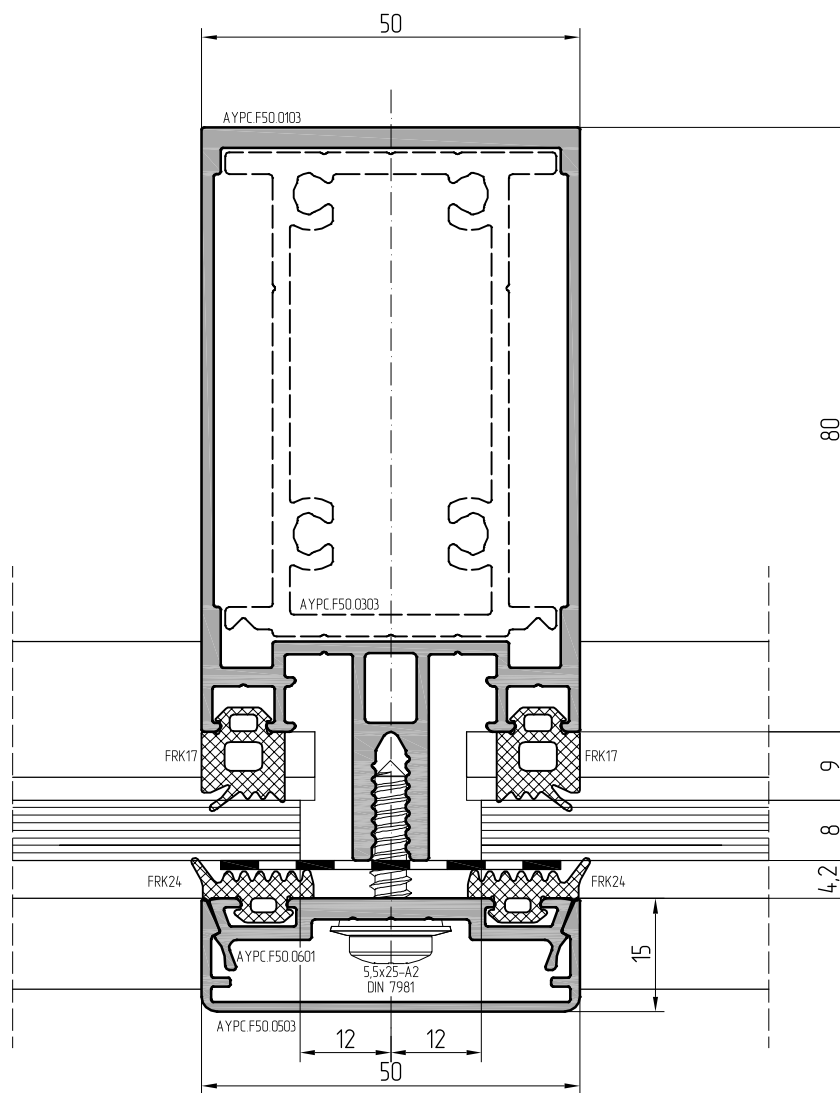
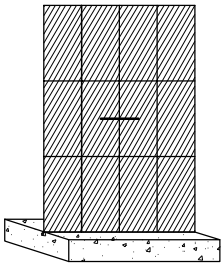

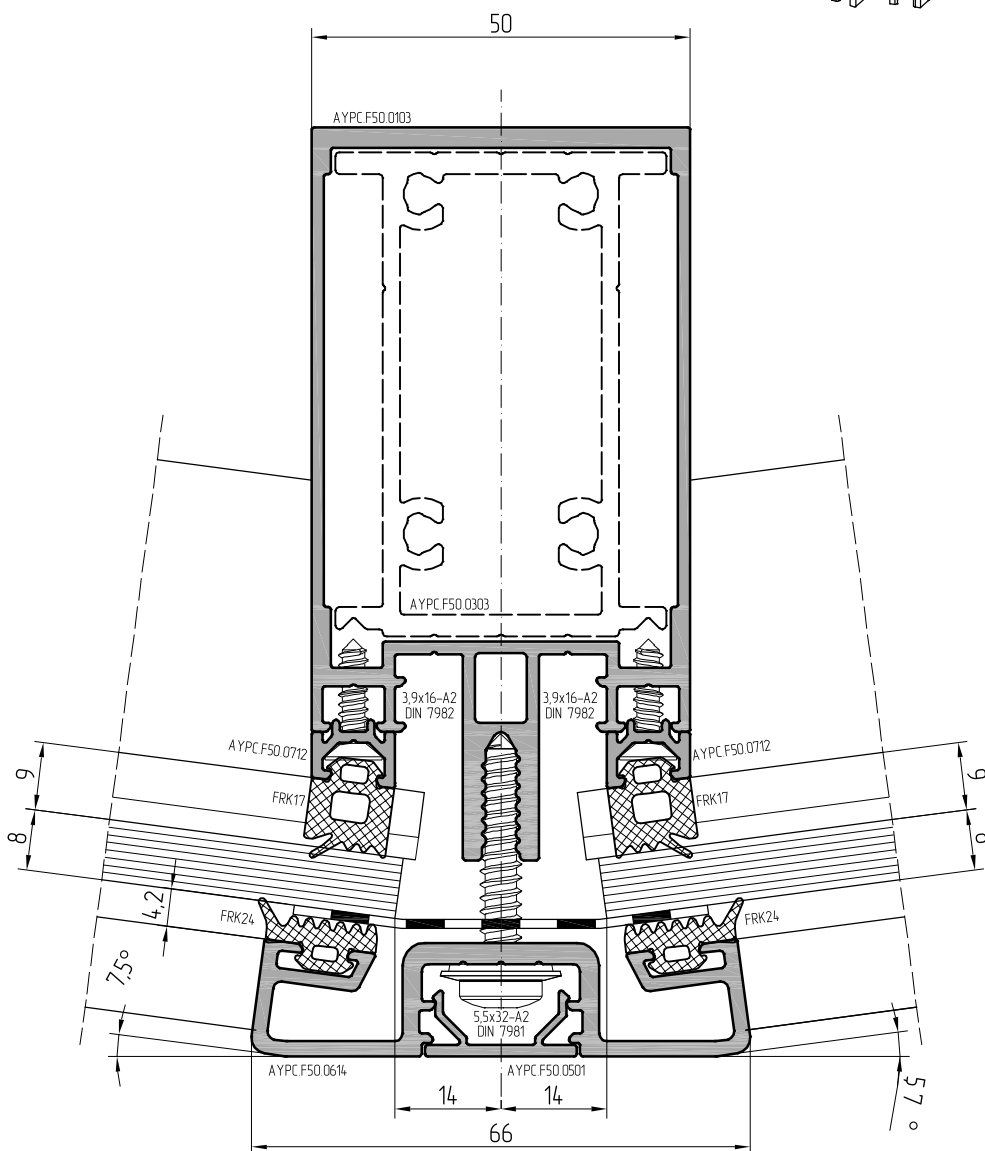
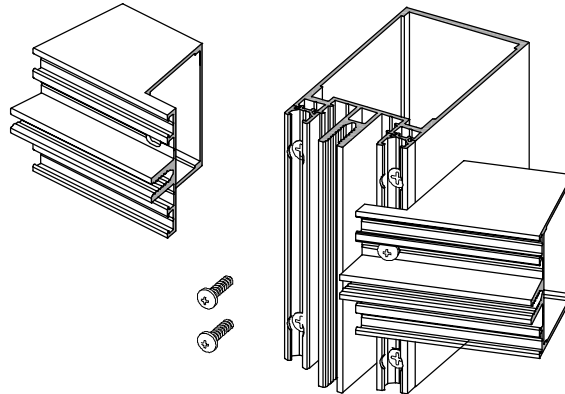
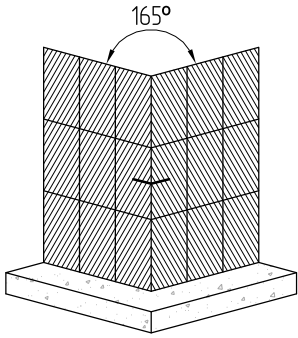

Scale 1:1

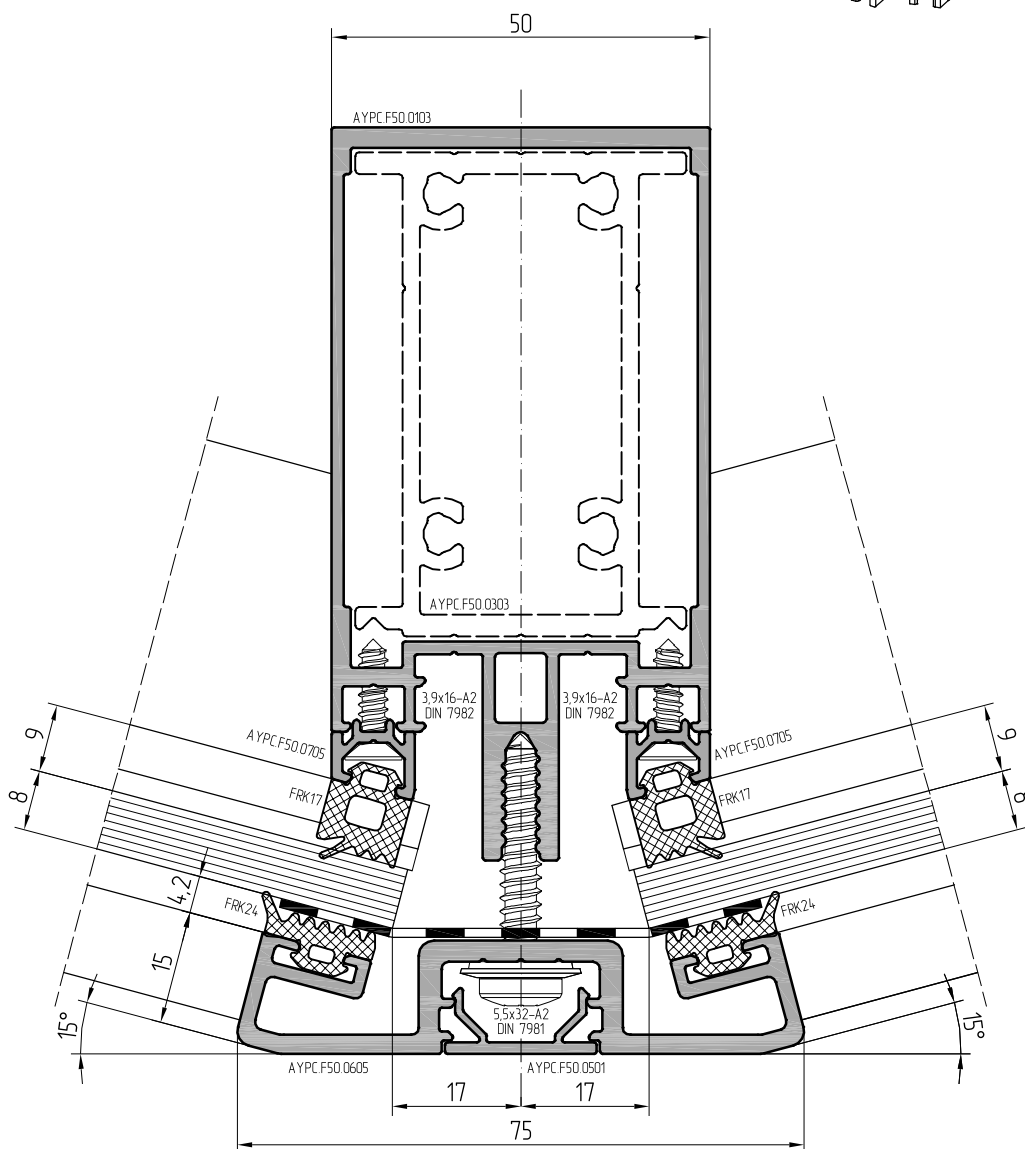
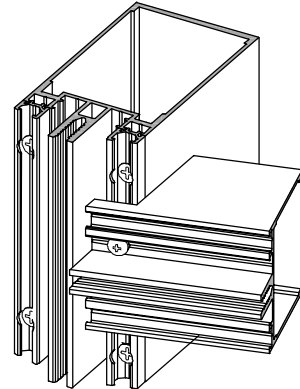
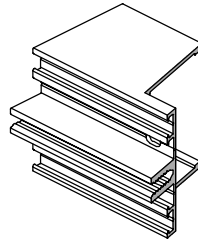
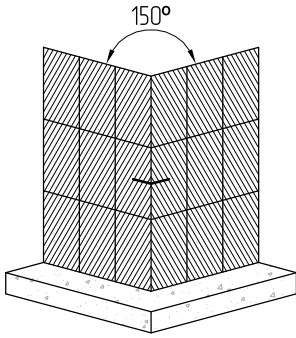

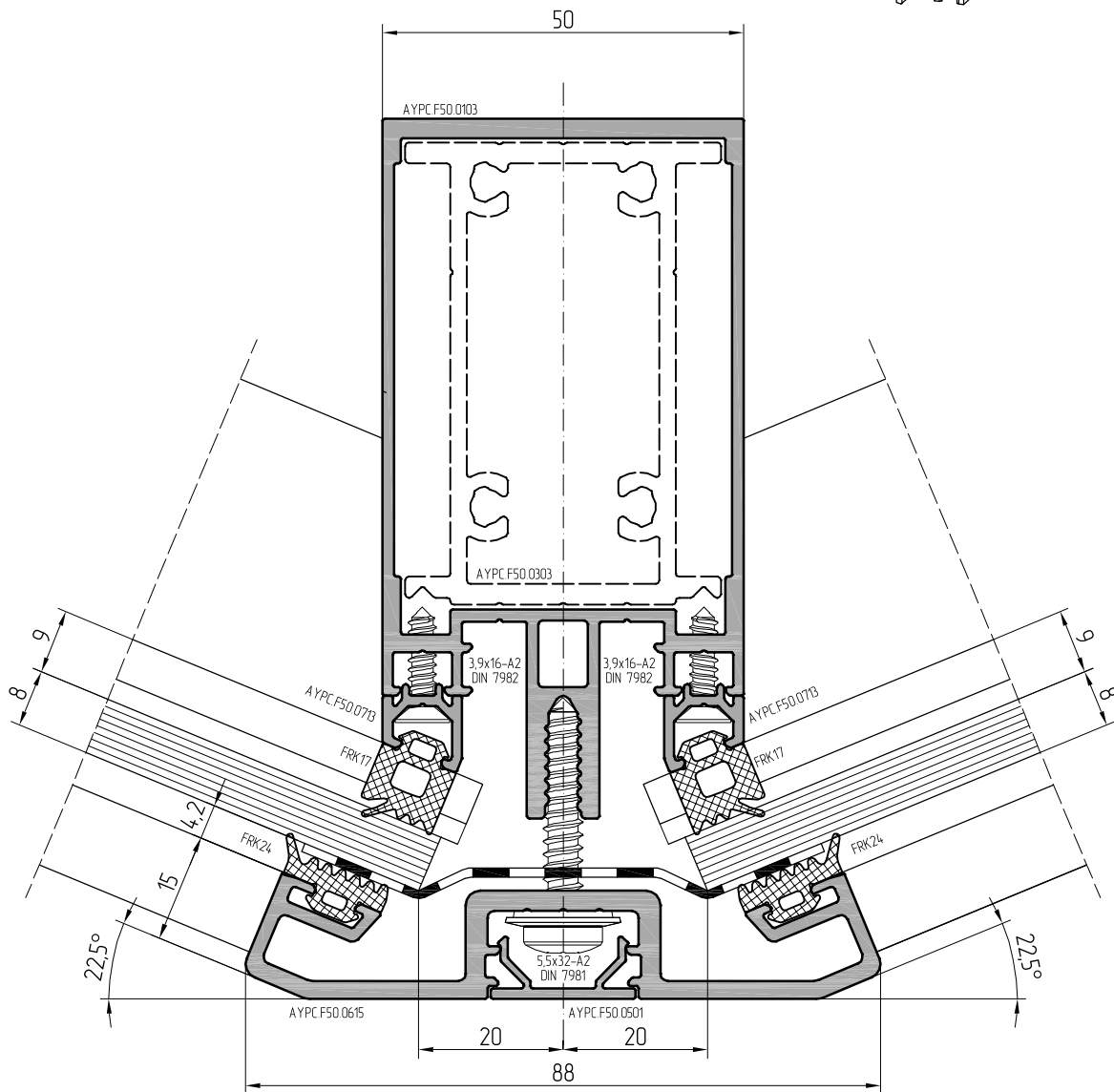
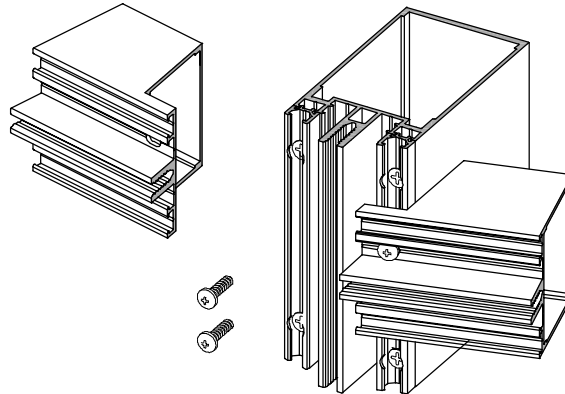
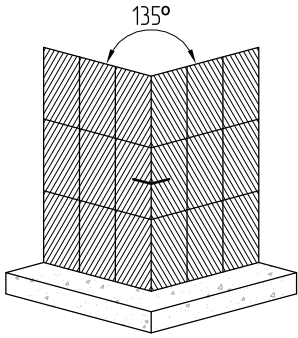

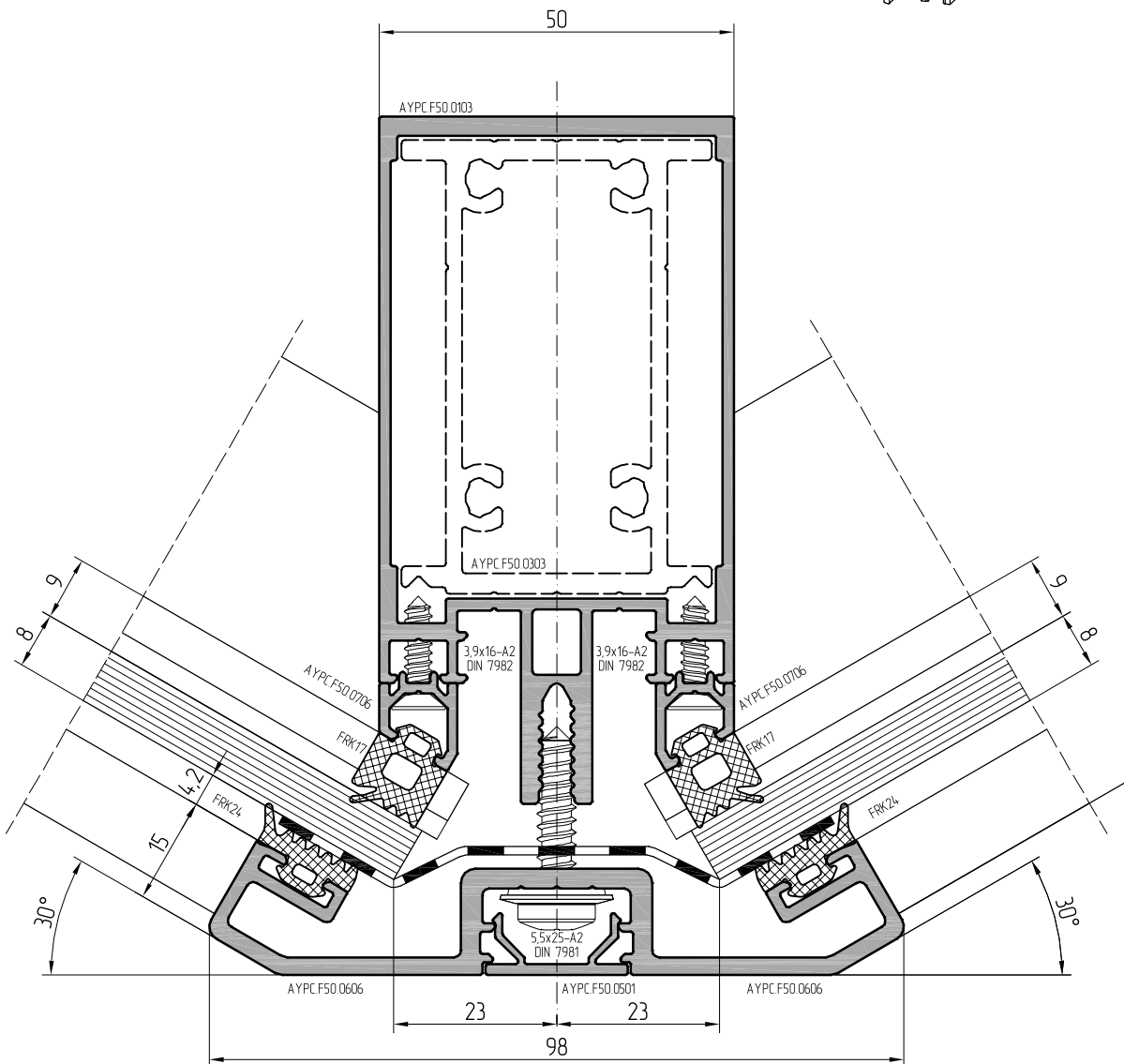
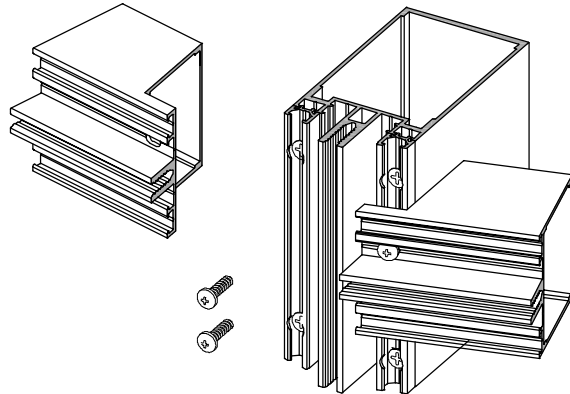
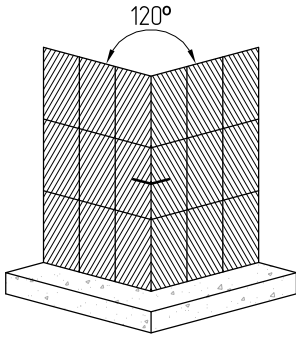

- 01
- 02
- 03
- 04
- 05
- 06
- 07
- 08
- 09
- 10
- 11
- 12
- 13



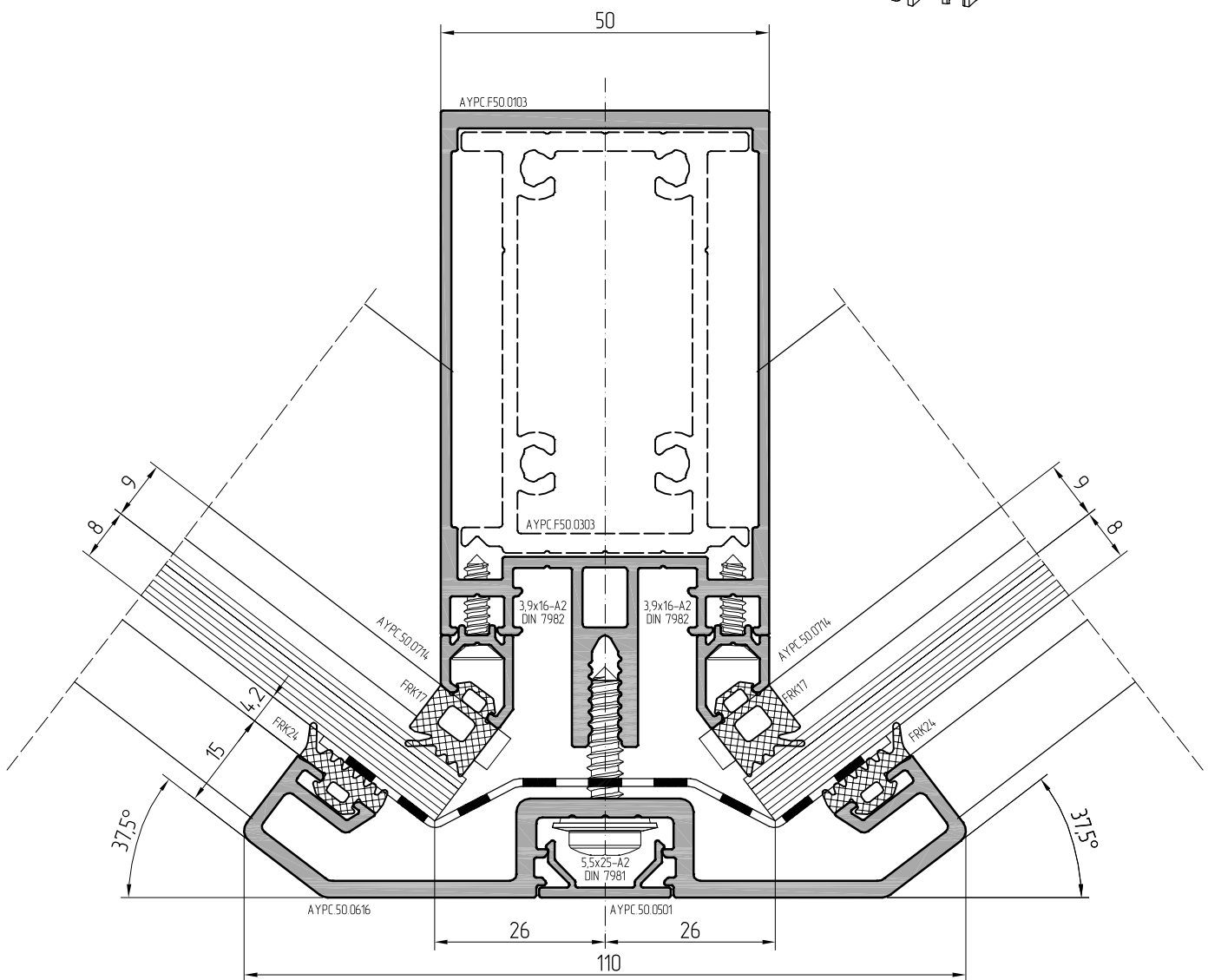
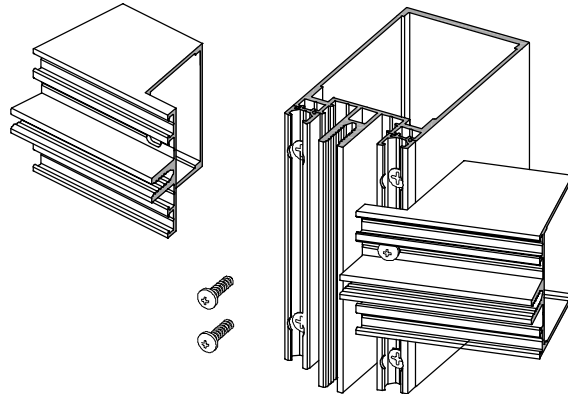
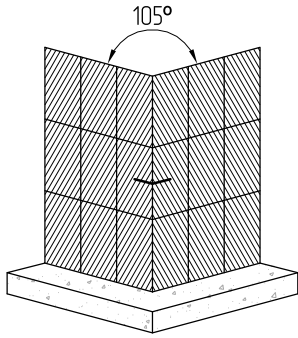



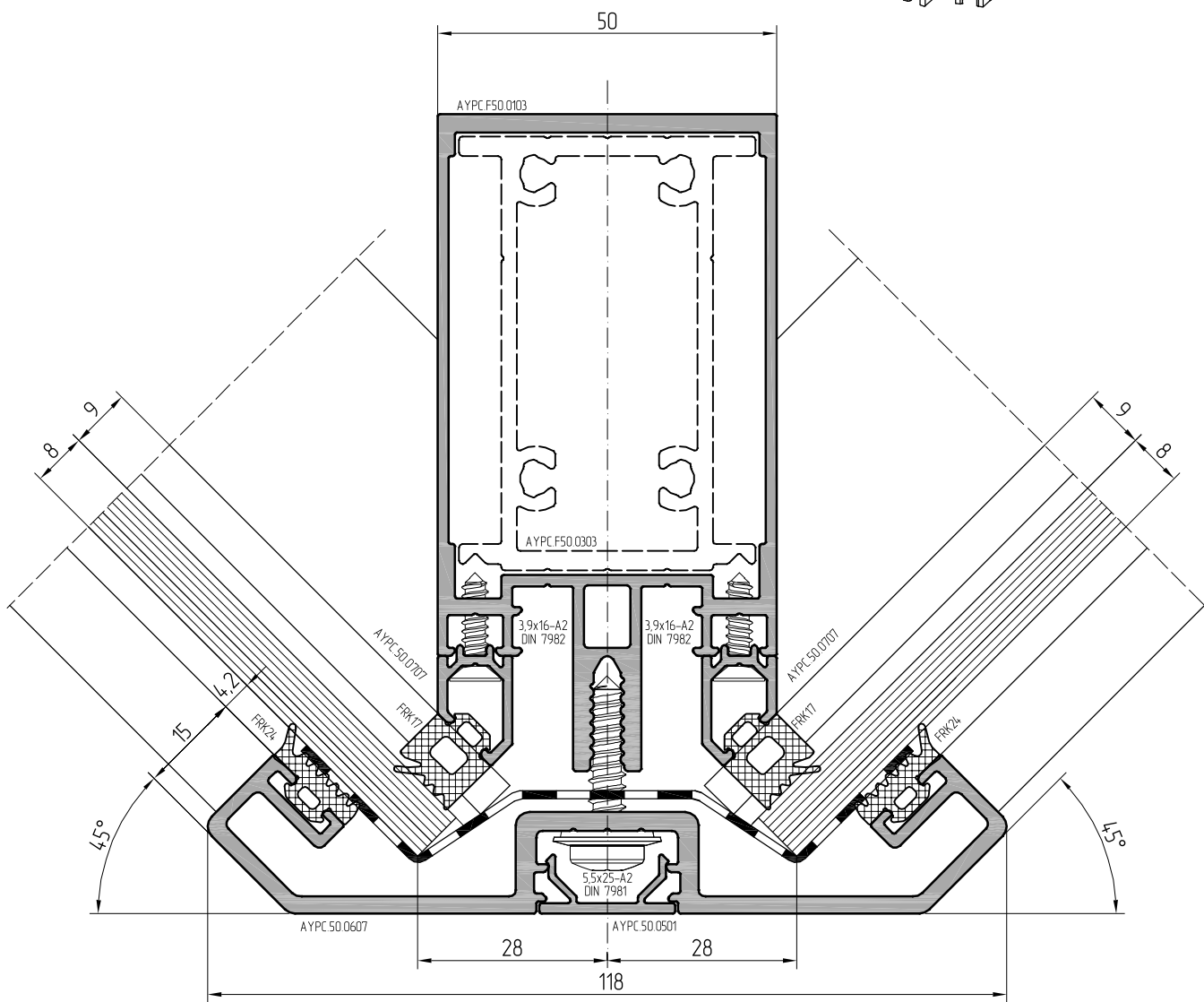
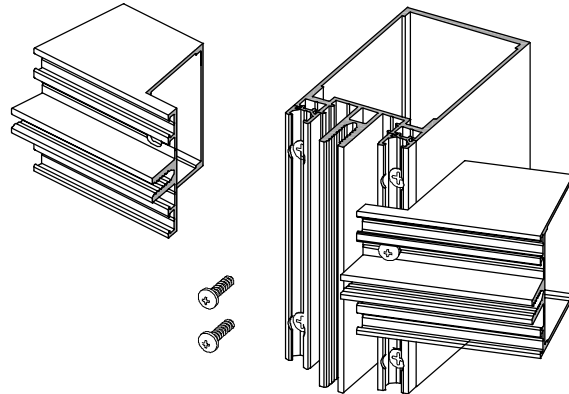
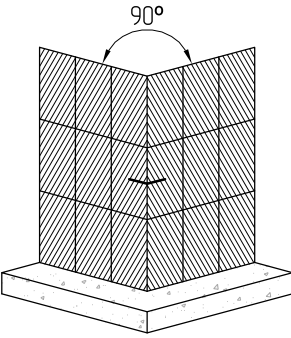

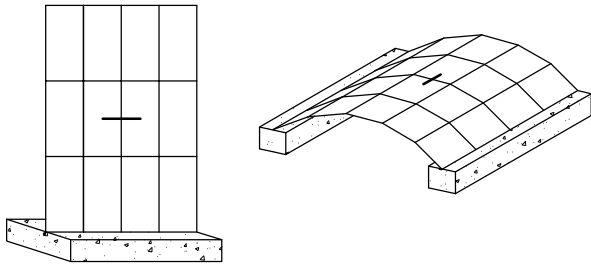

Option

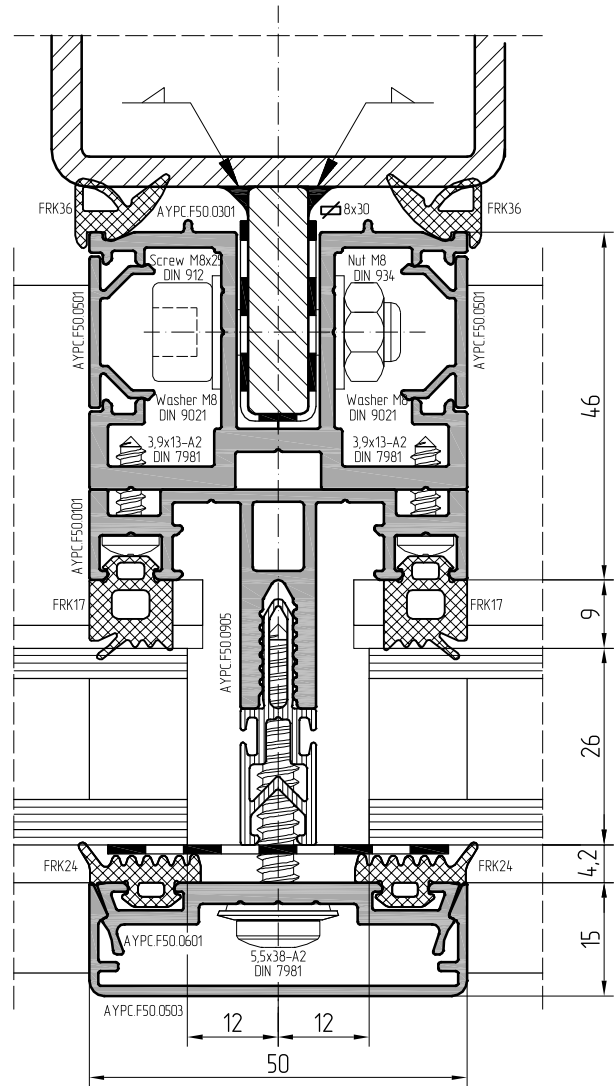
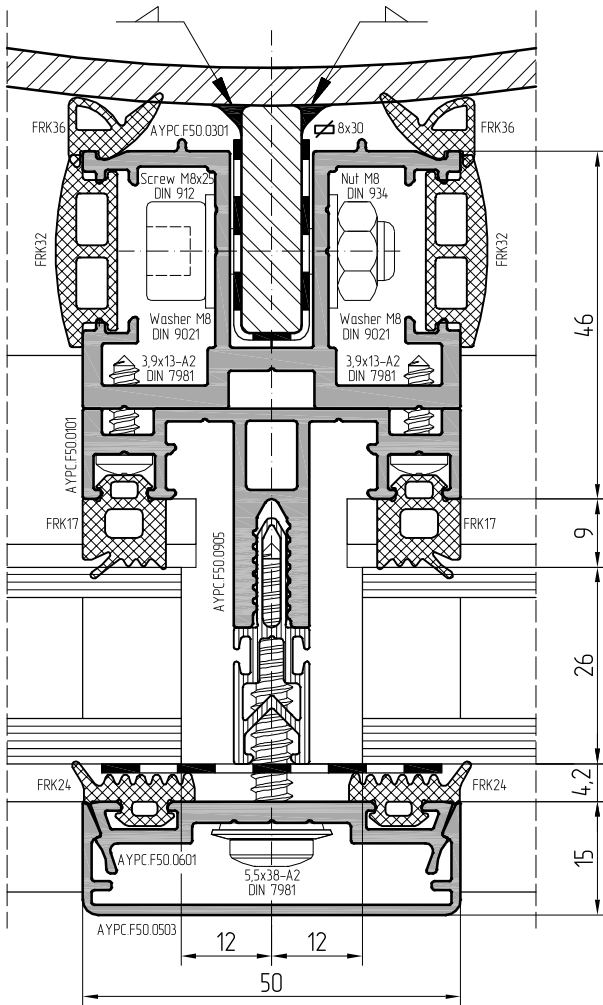

Option

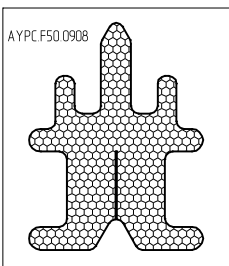

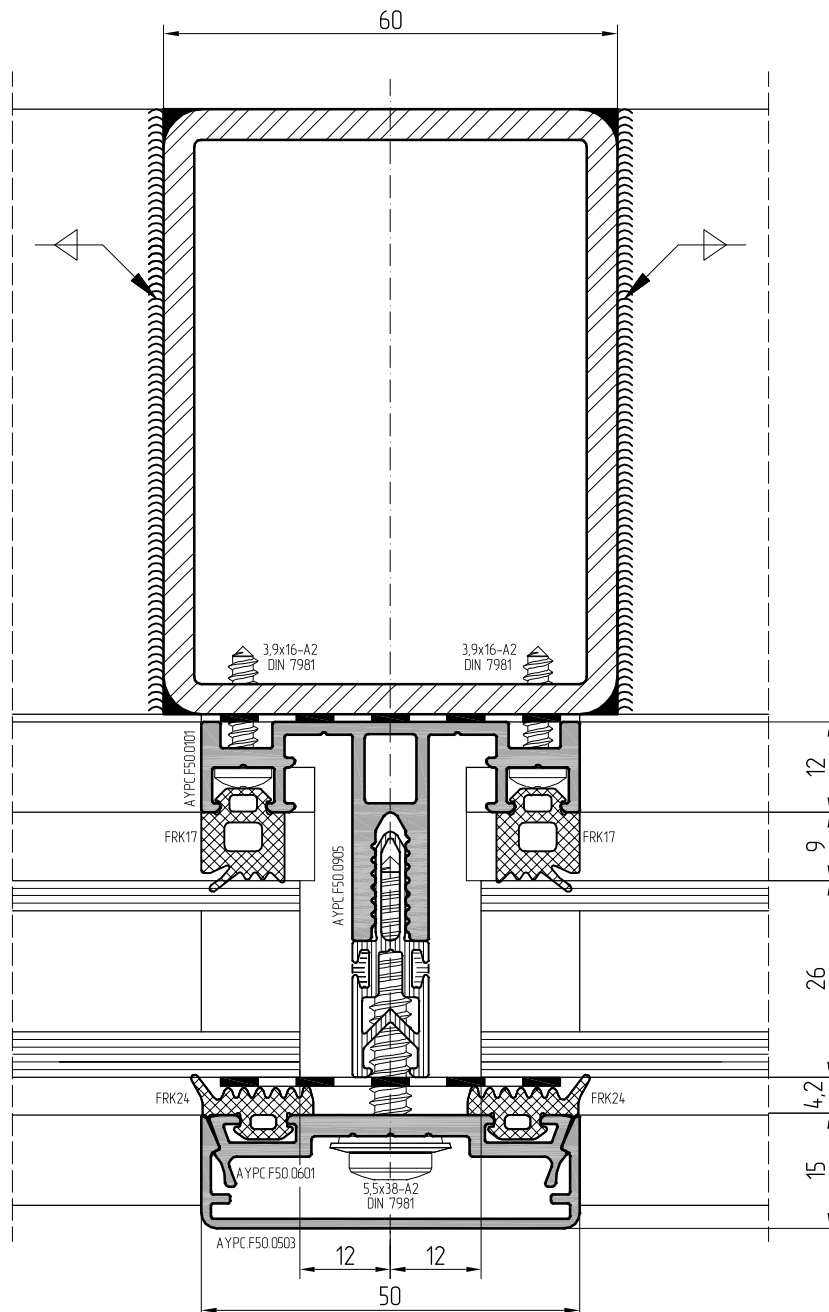
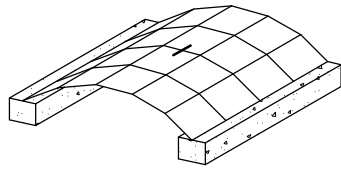
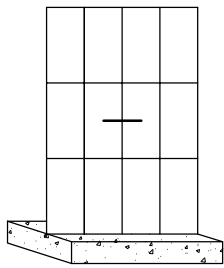

Option

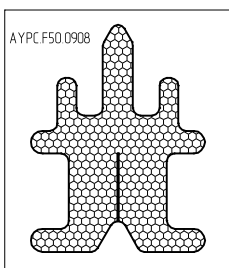

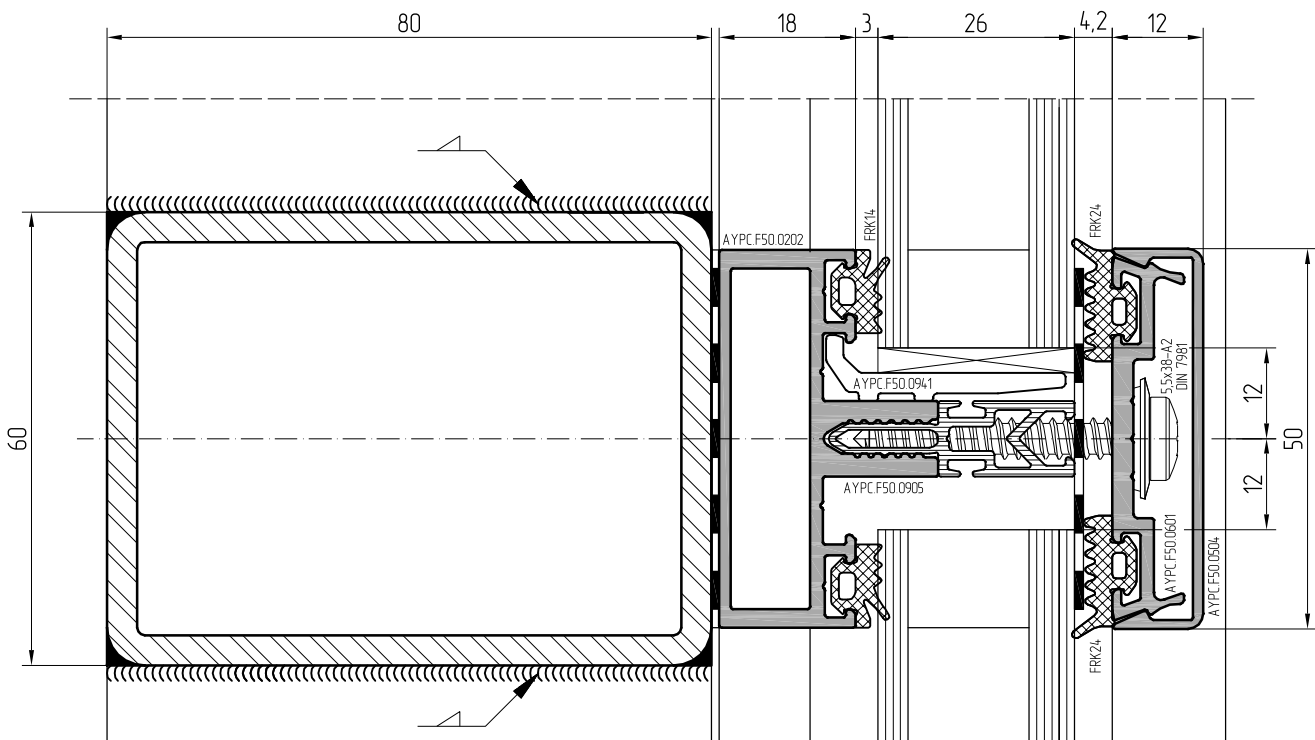
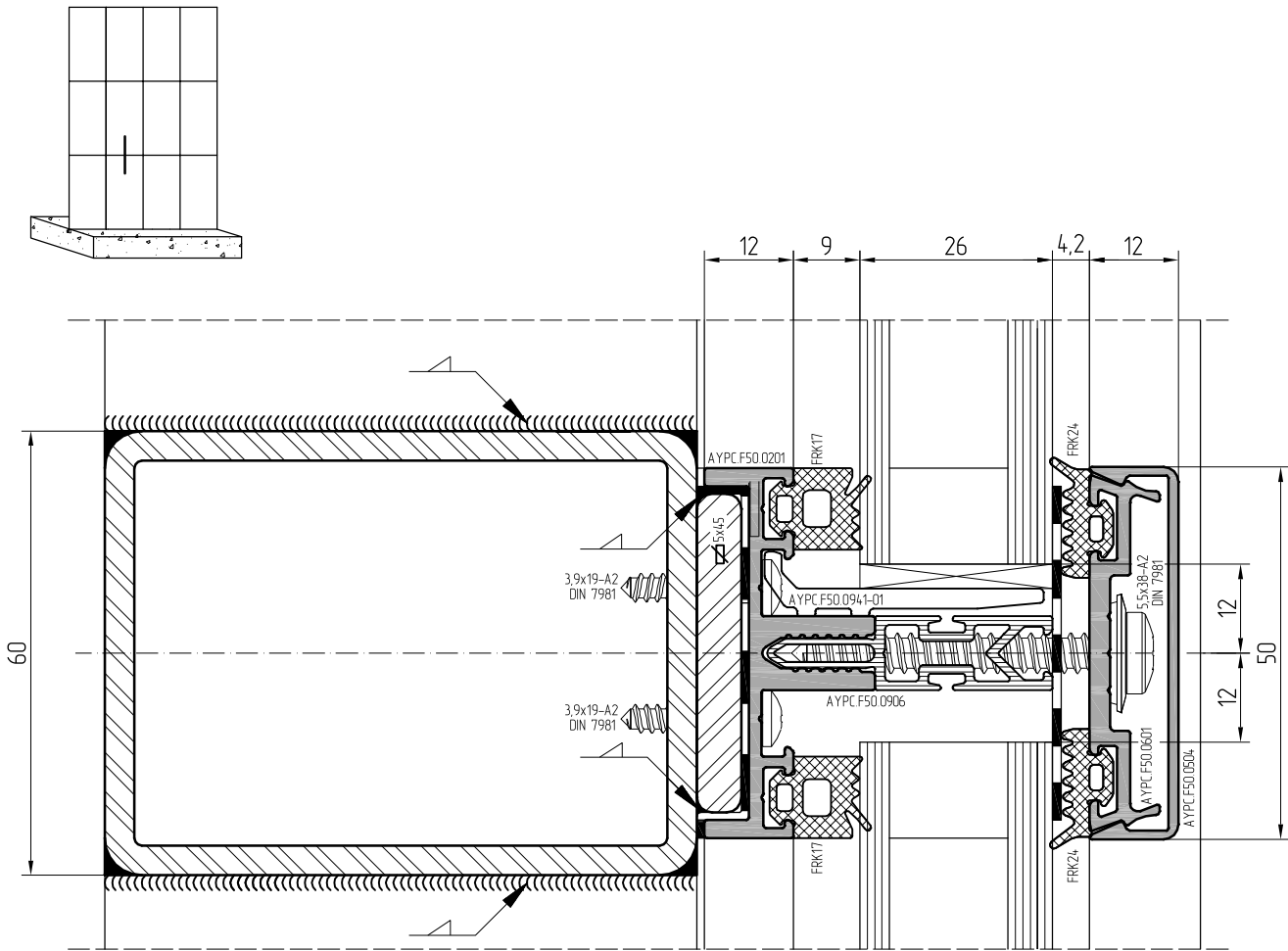

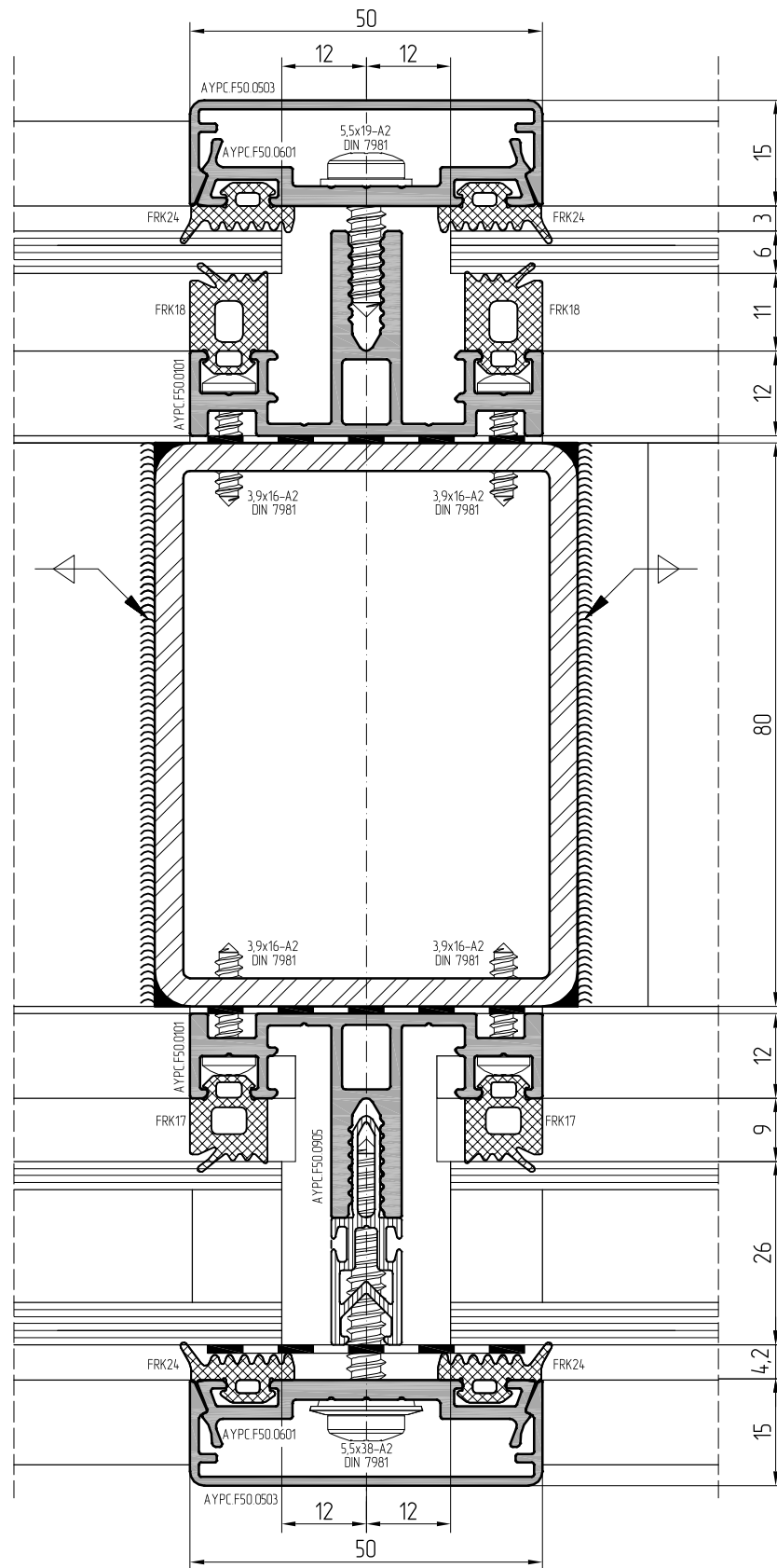
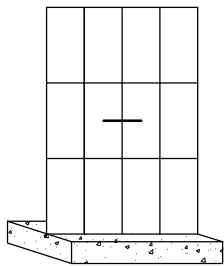

Option

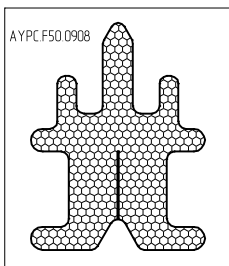

- 01
- 02
- 03
- 04
- 05
- 06
- 07
- 08
- 09
- 10
- 11
- 12
- 13

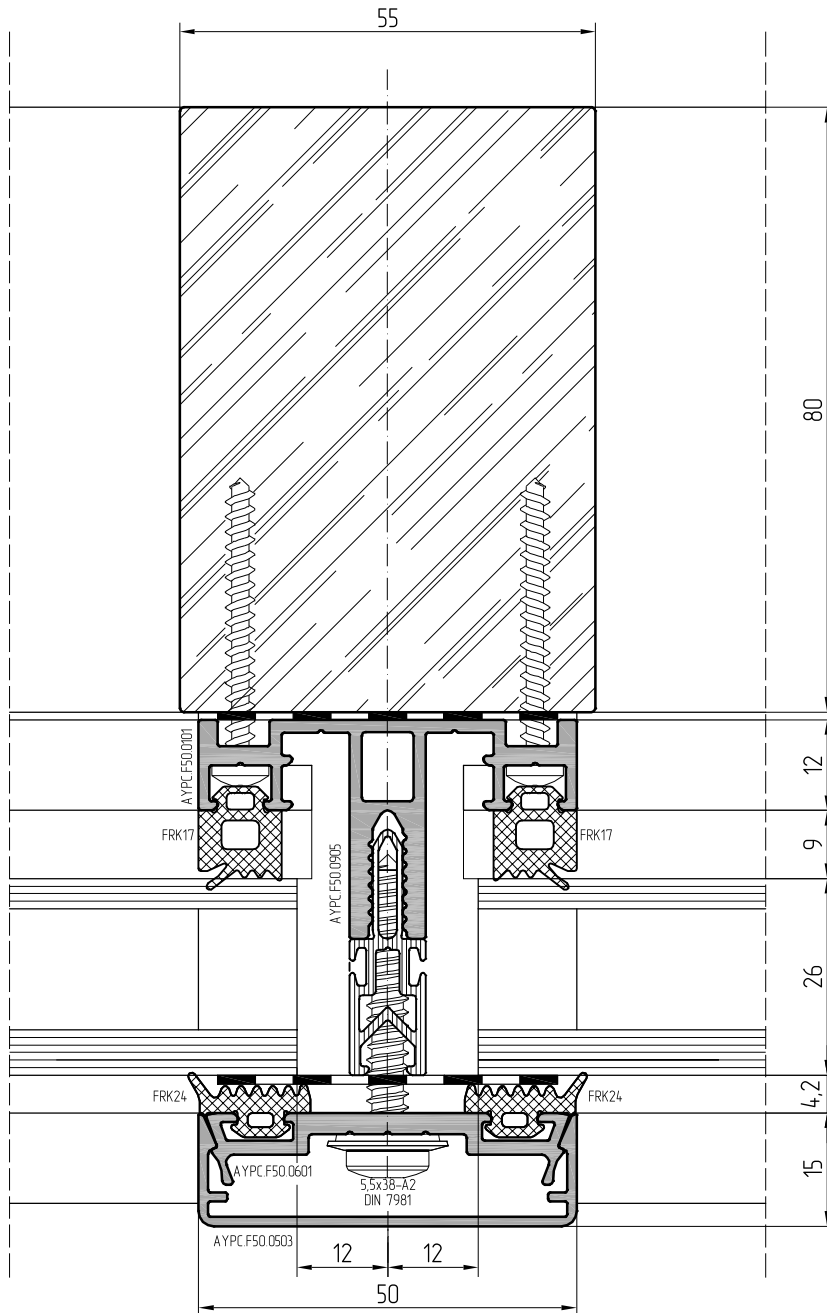
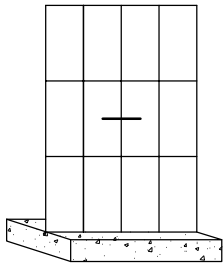

Option

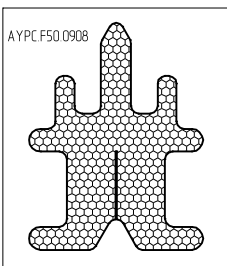

Option

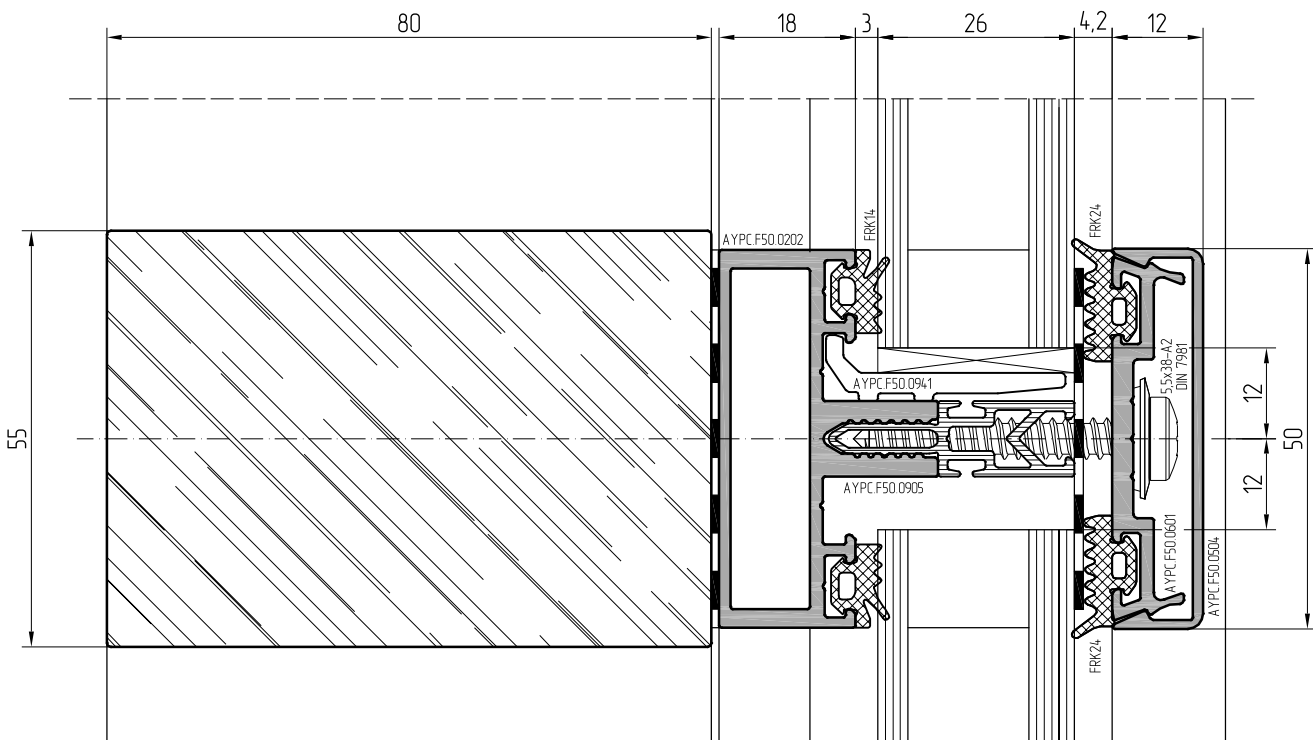
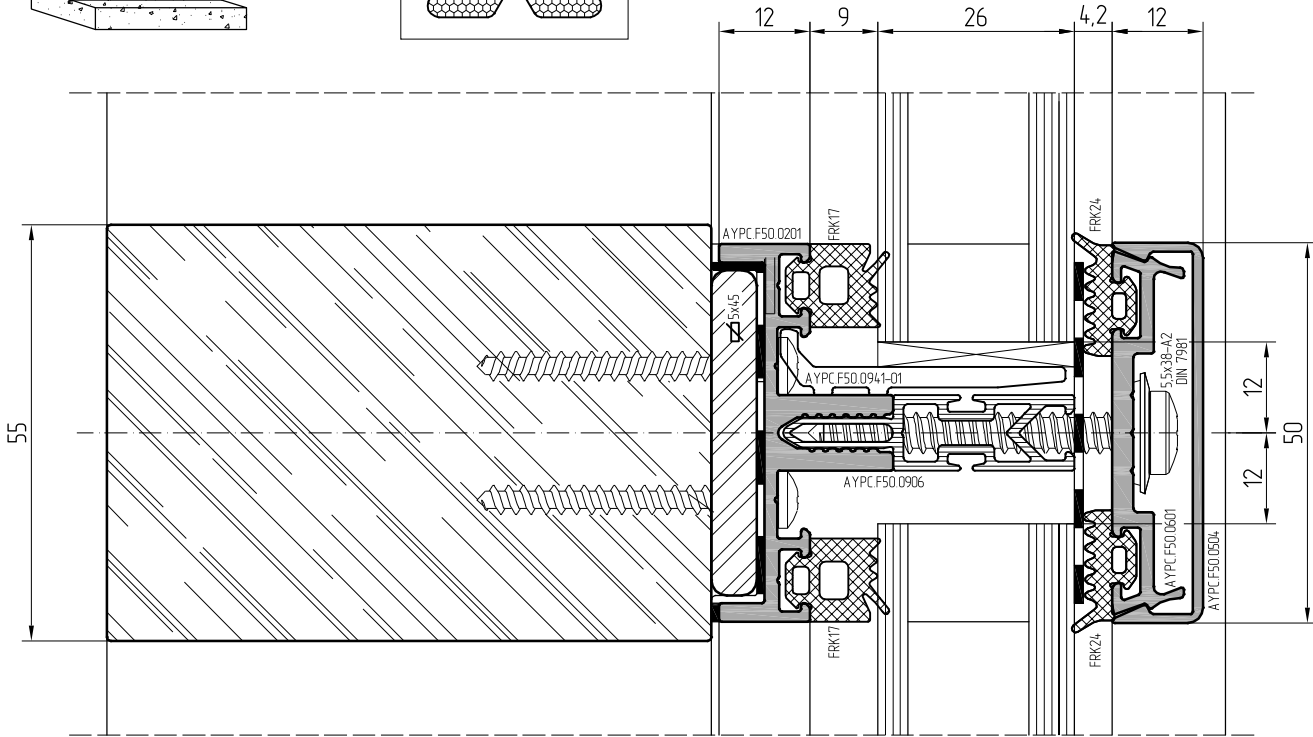
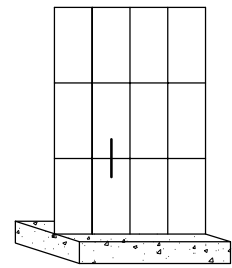
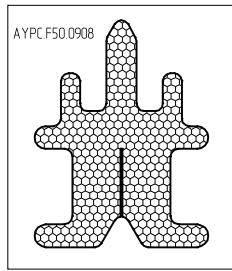

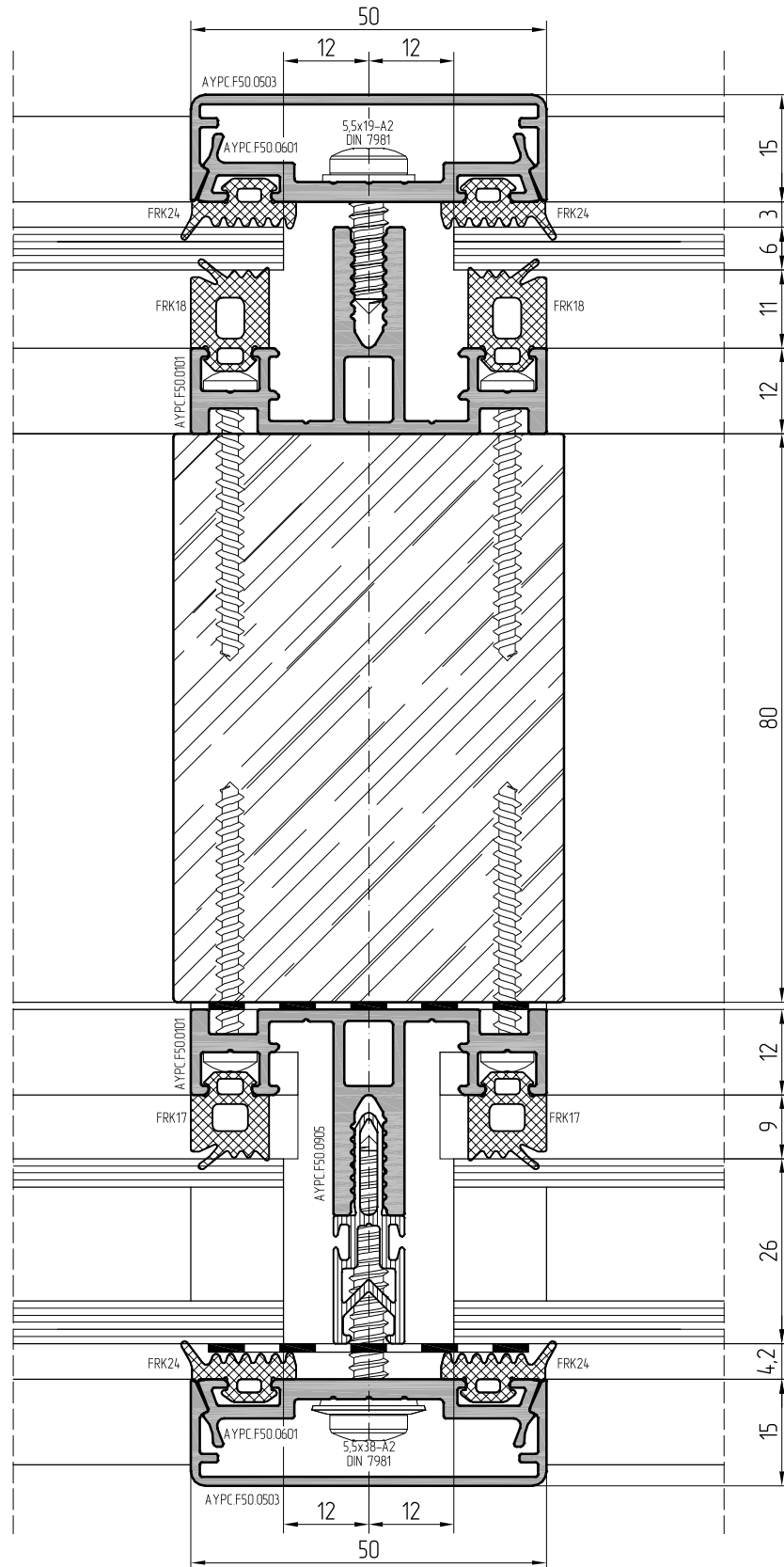
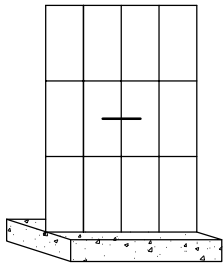

Option

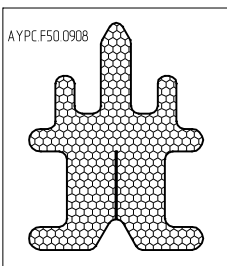



Scale 1:1

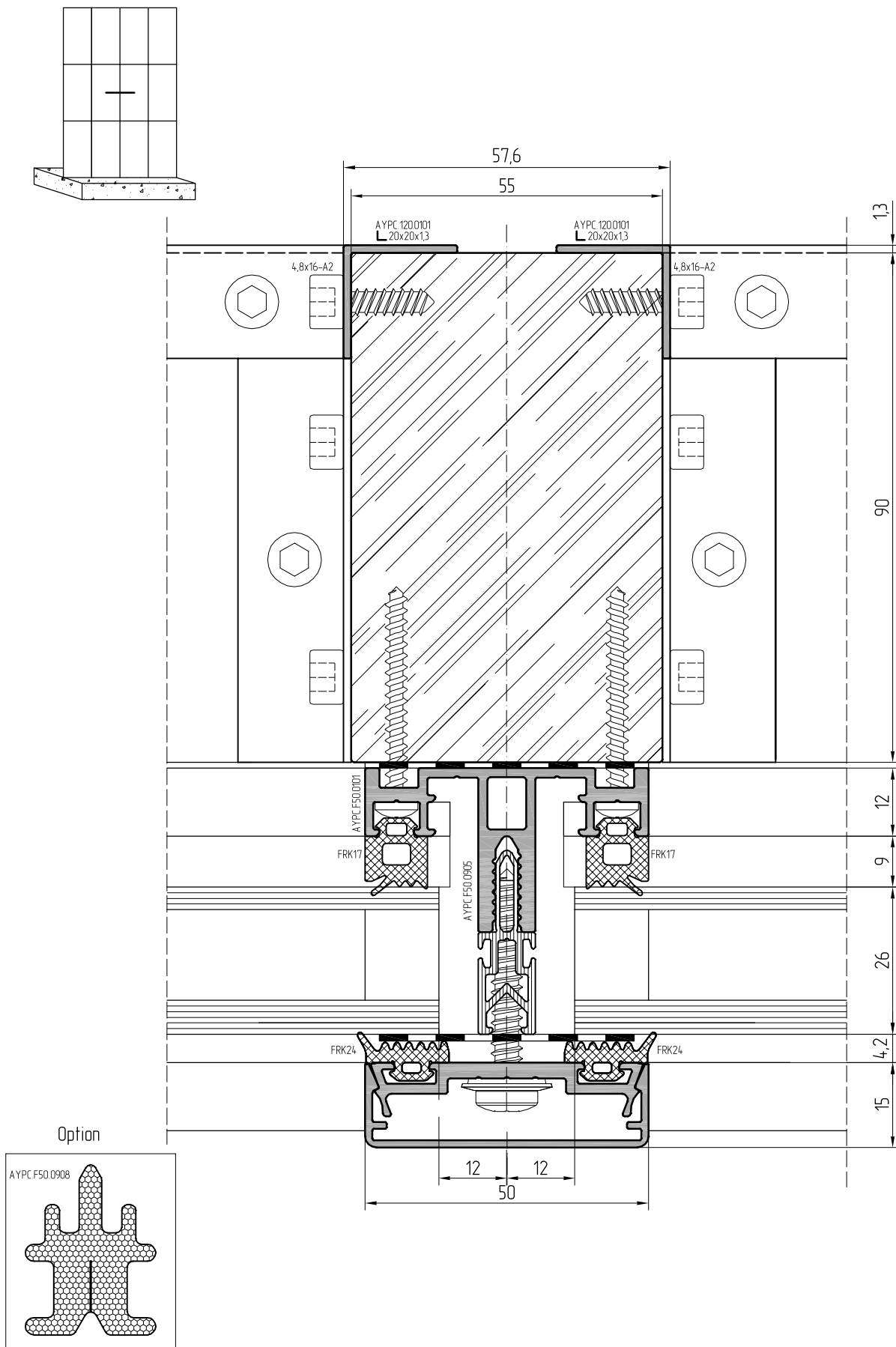

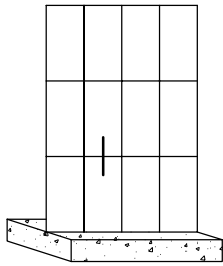

Option

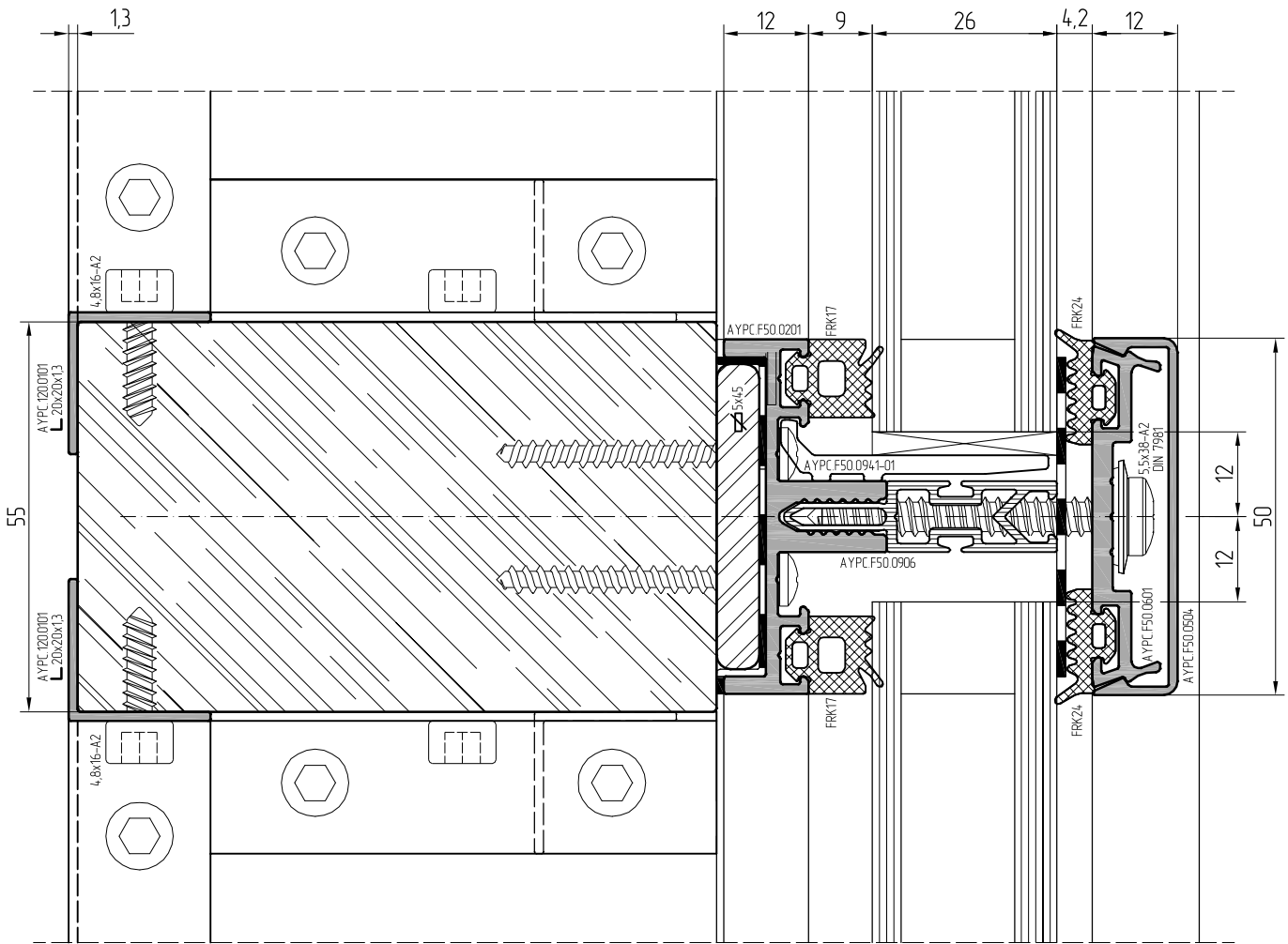
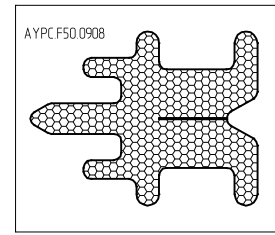

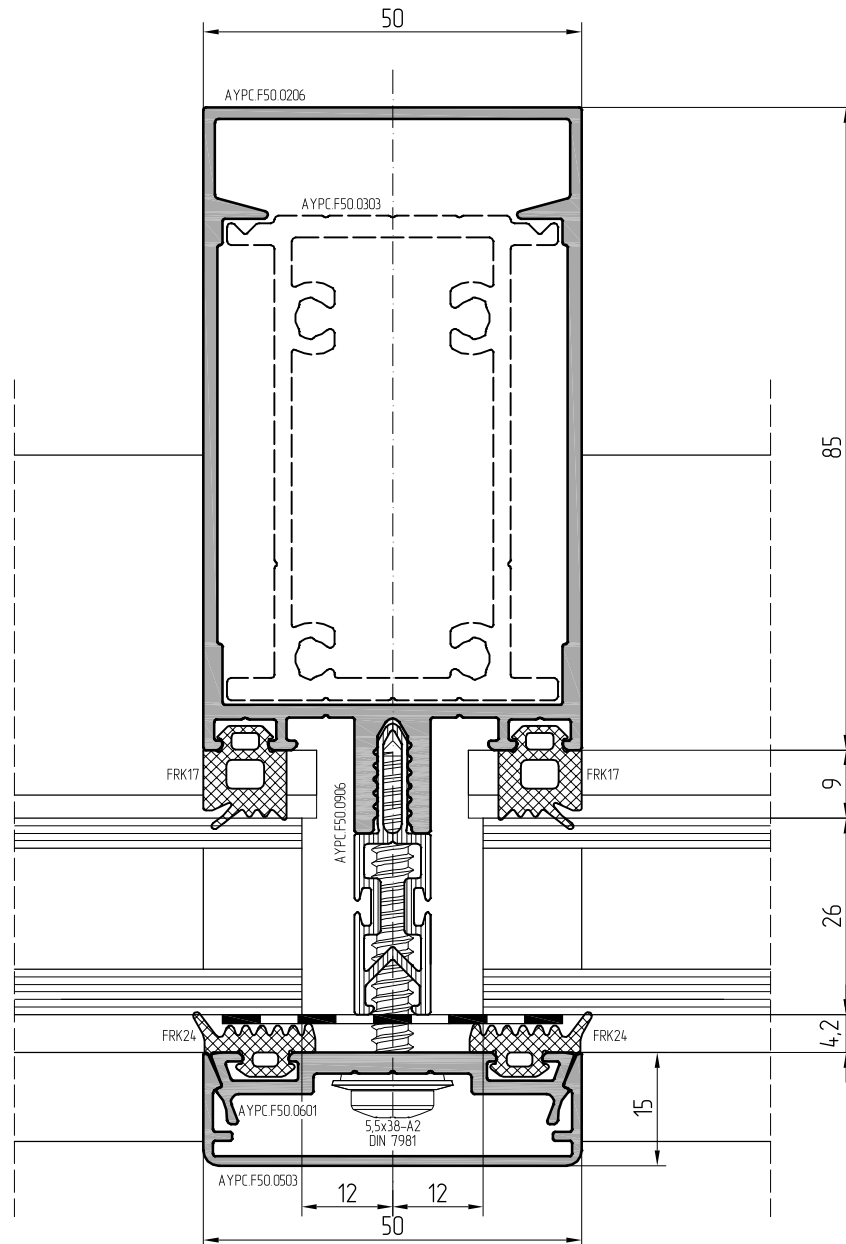
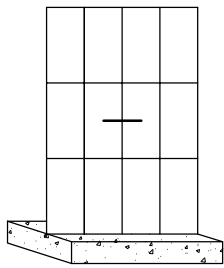

Option

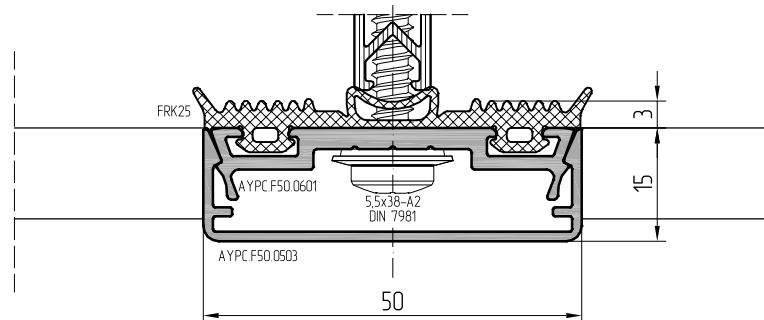

Option

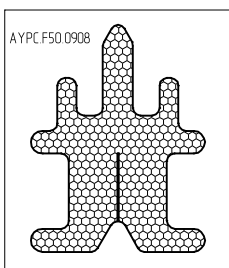

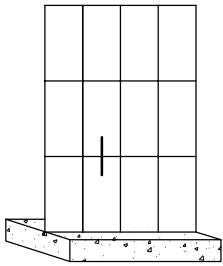

Option

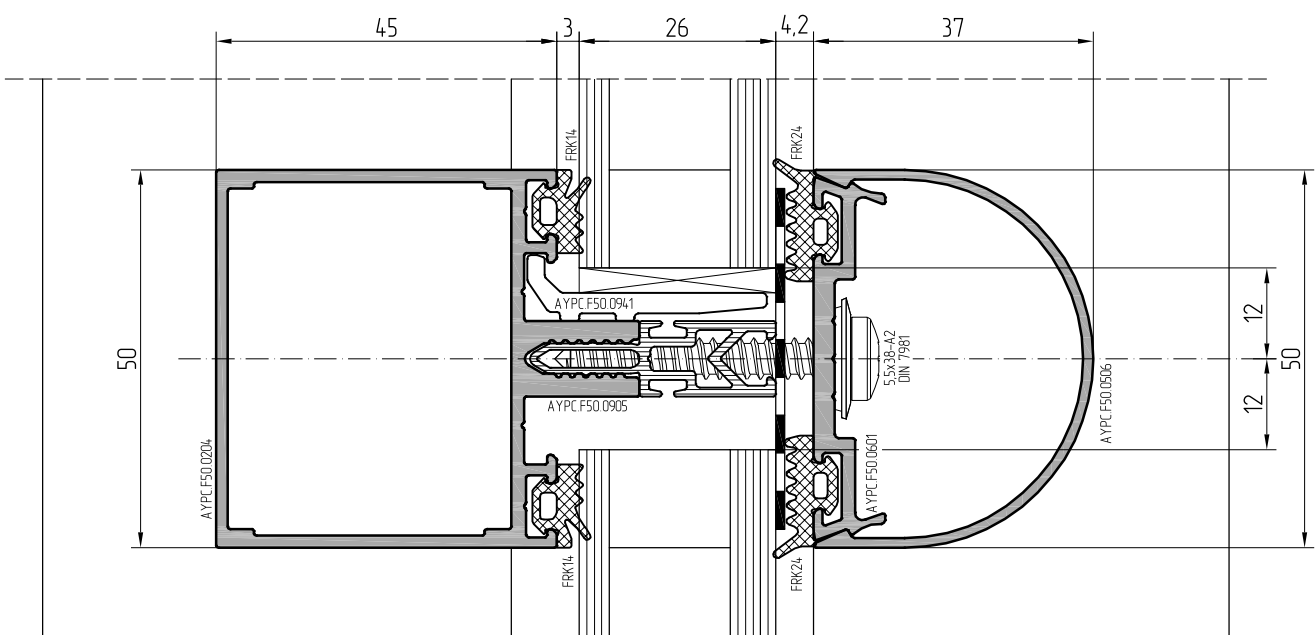
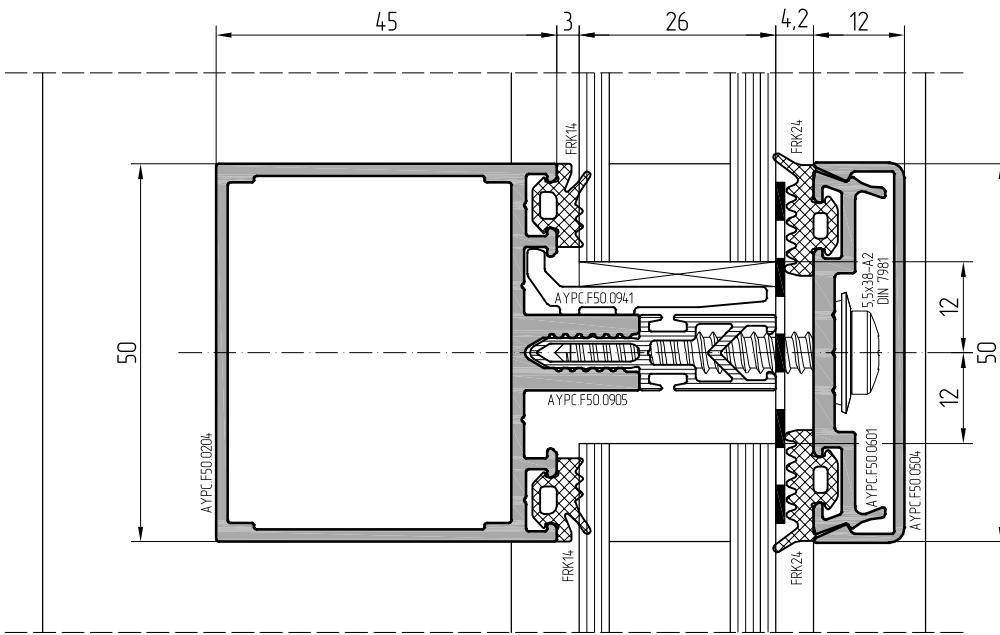
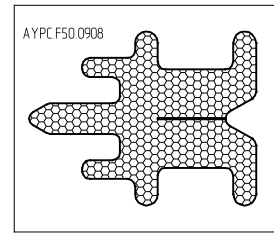

Scale 1:1

Option

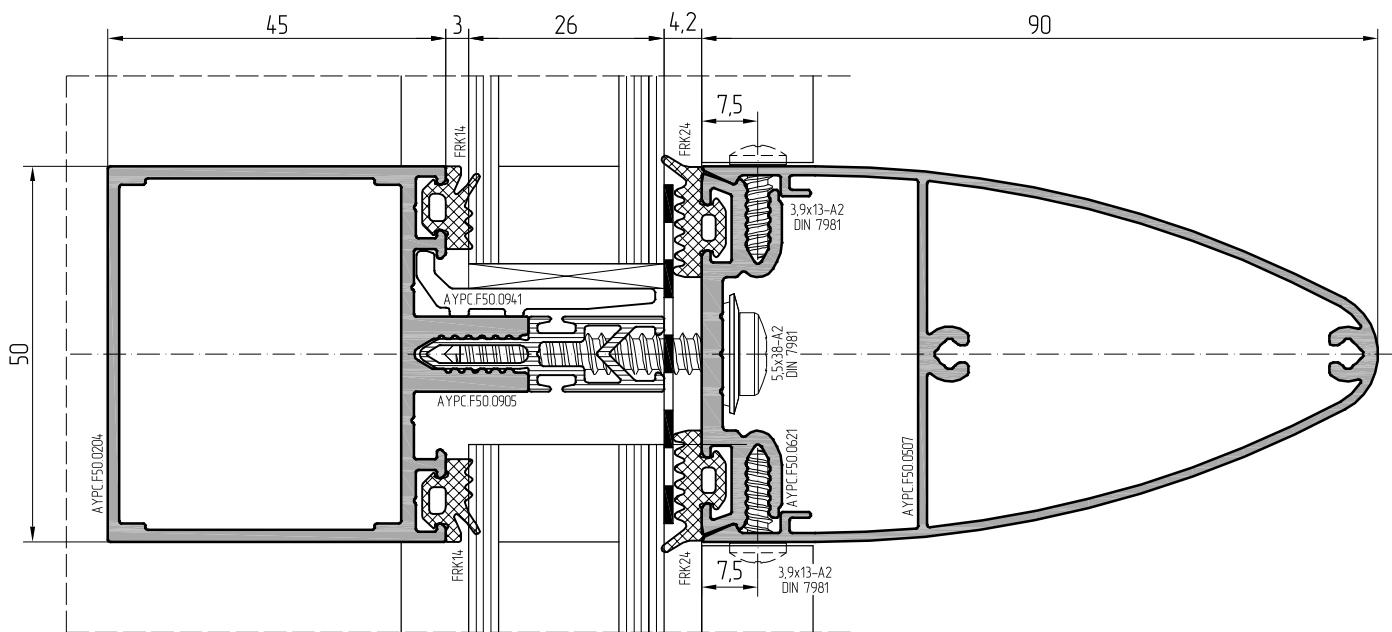
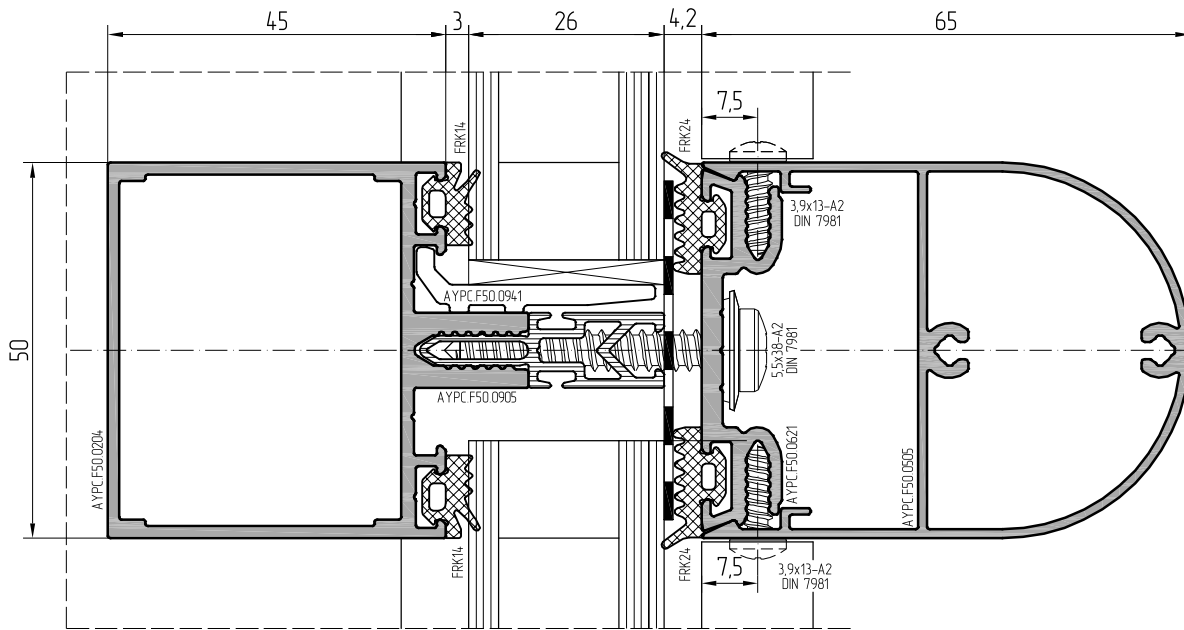
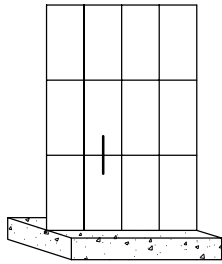
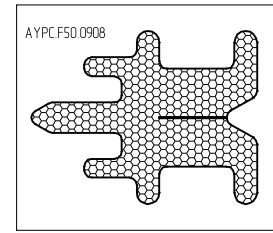

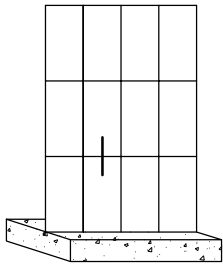

Option

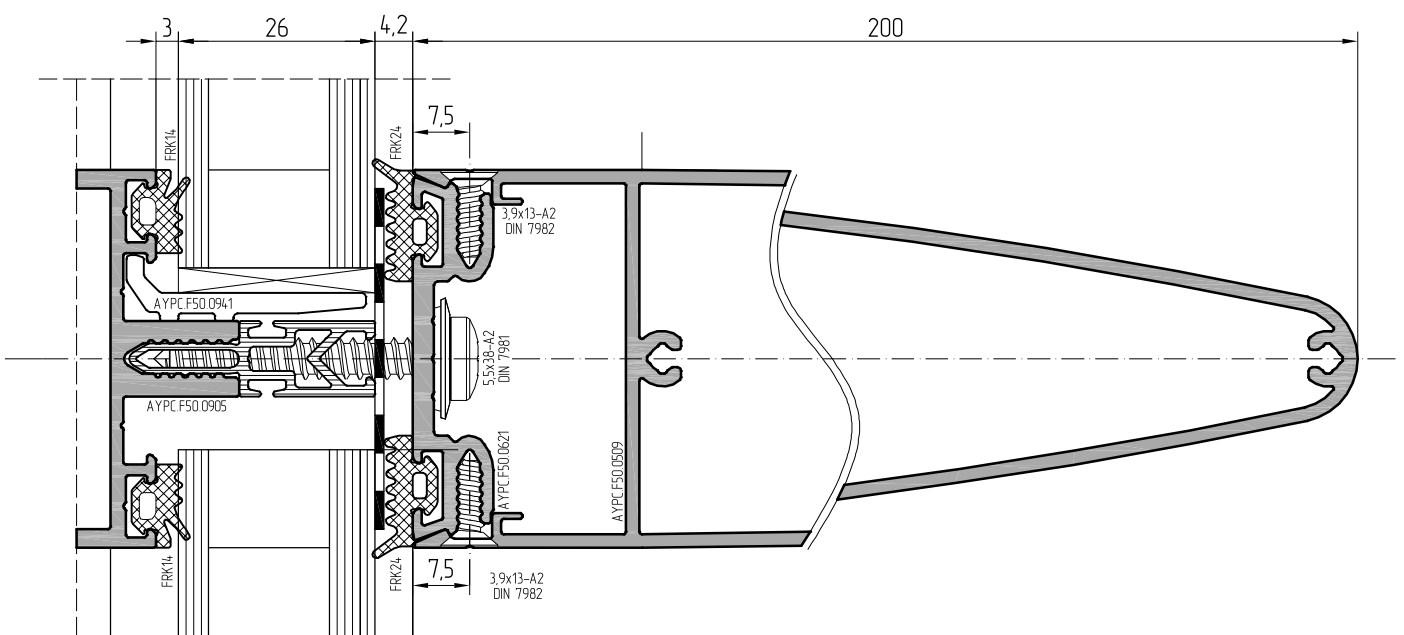
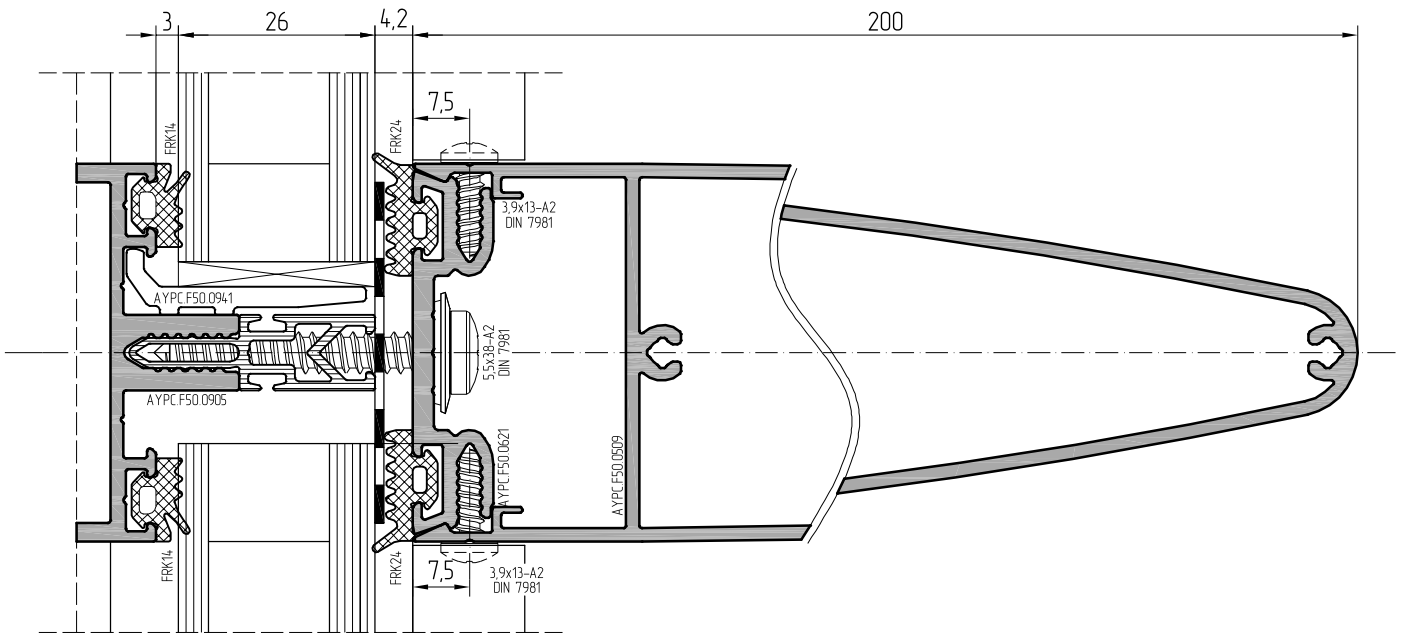
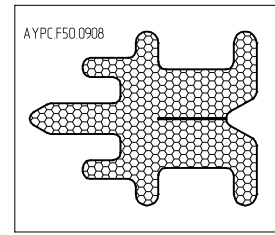

Scale 1:1

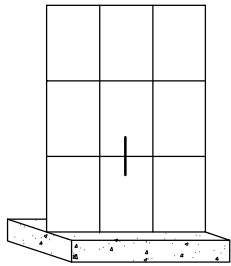

Option

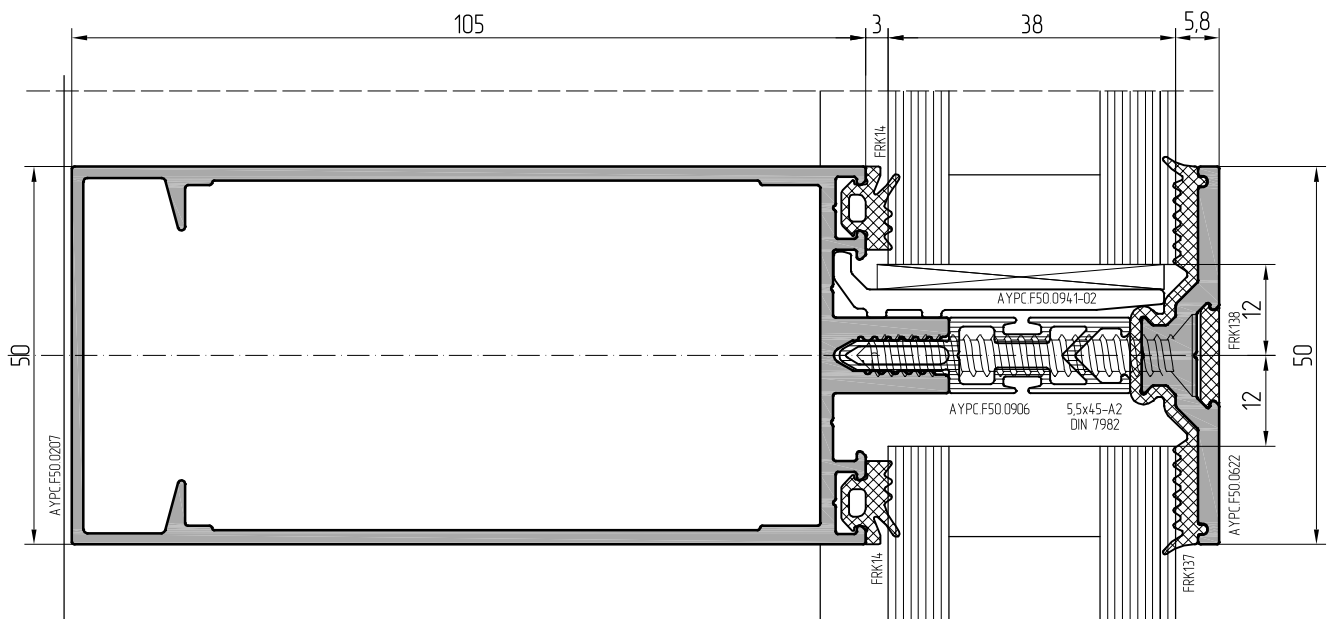
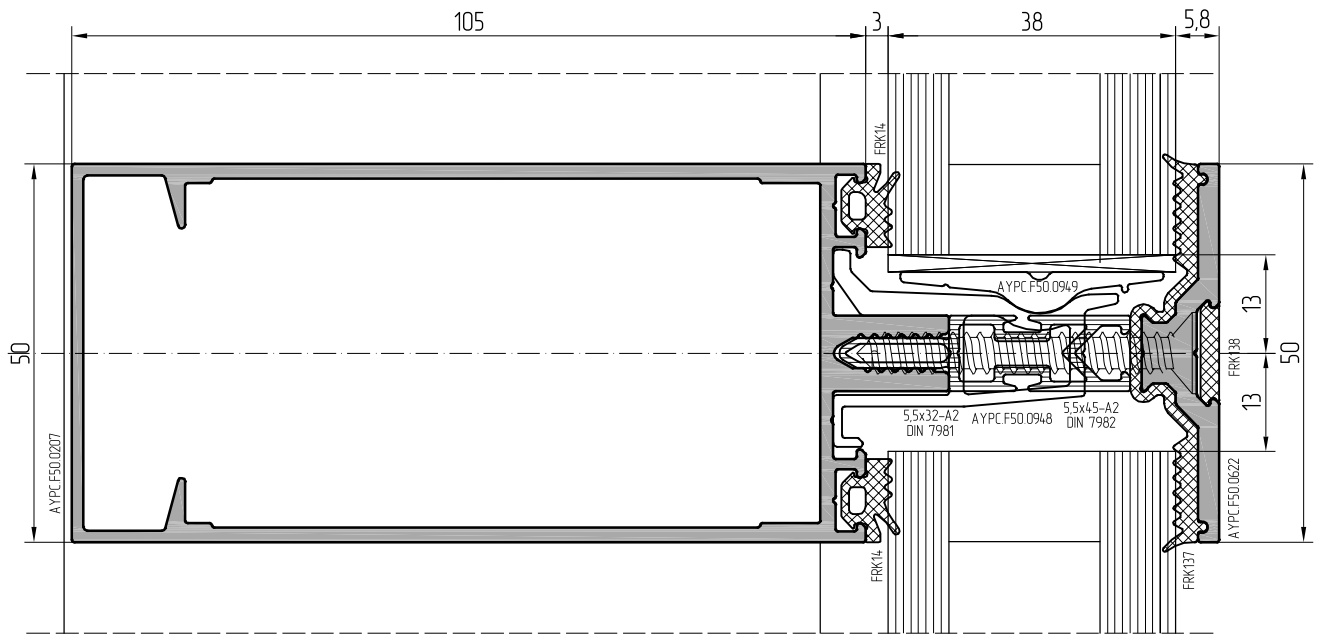
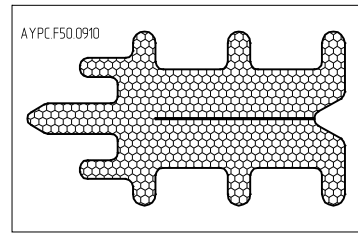

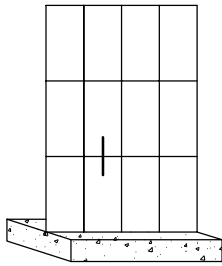

Option

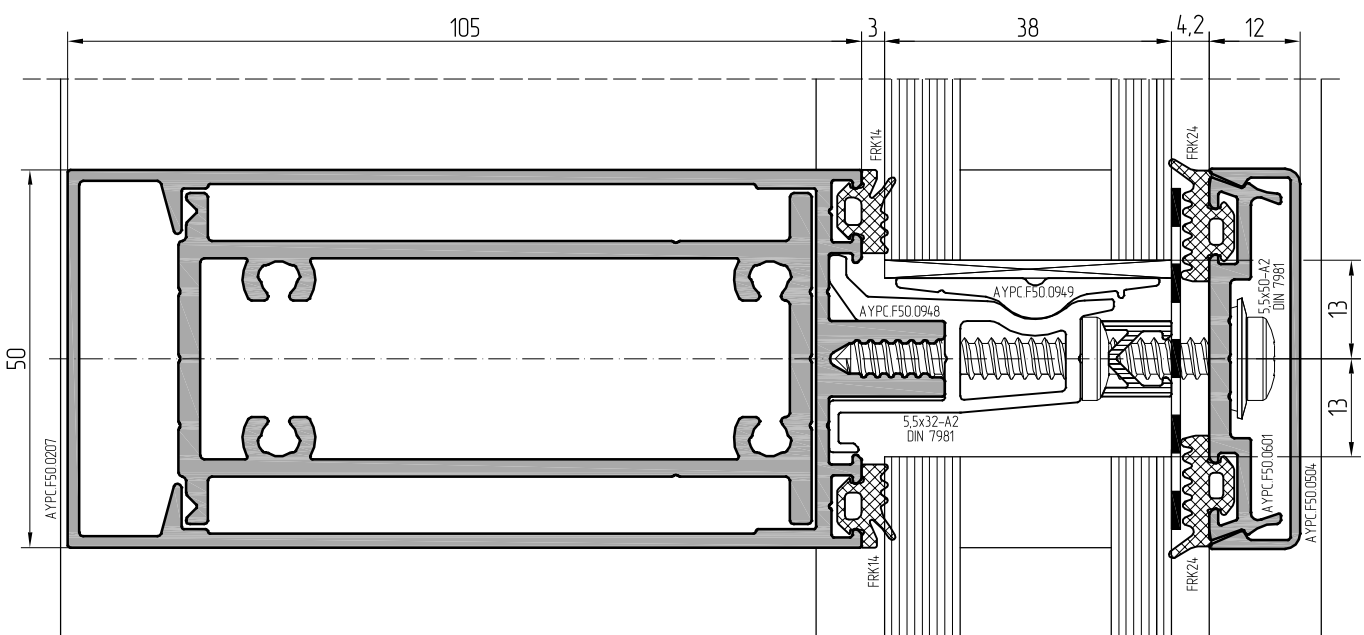
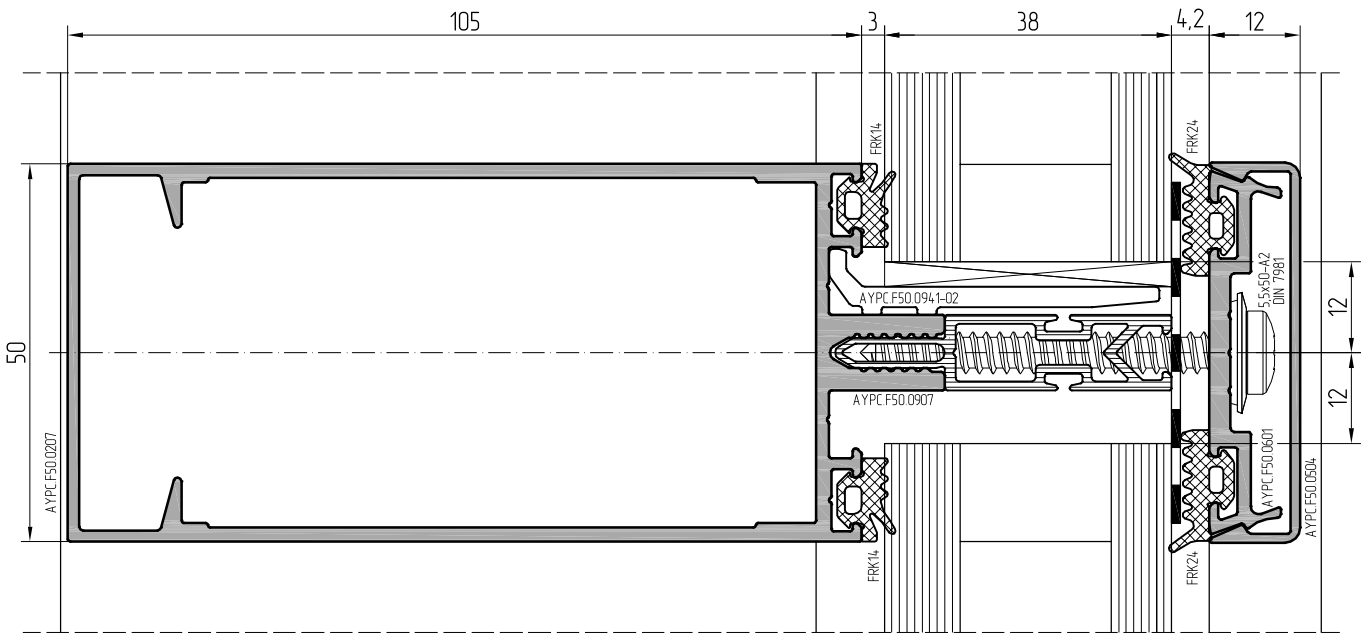
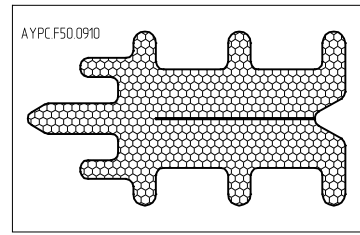



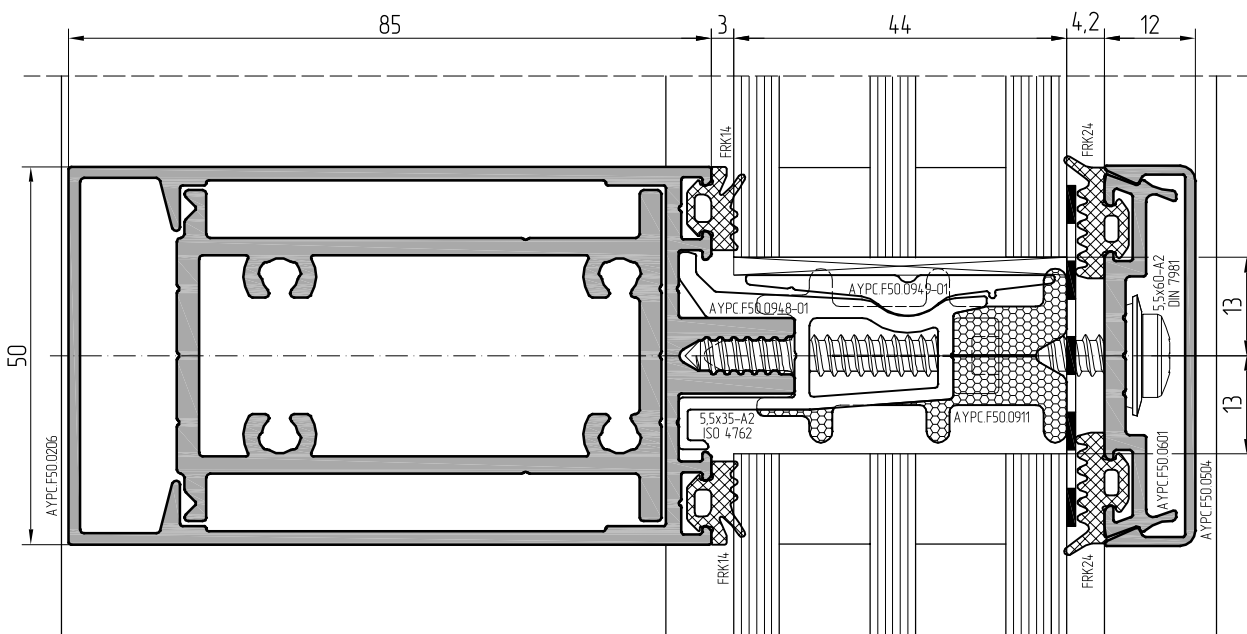
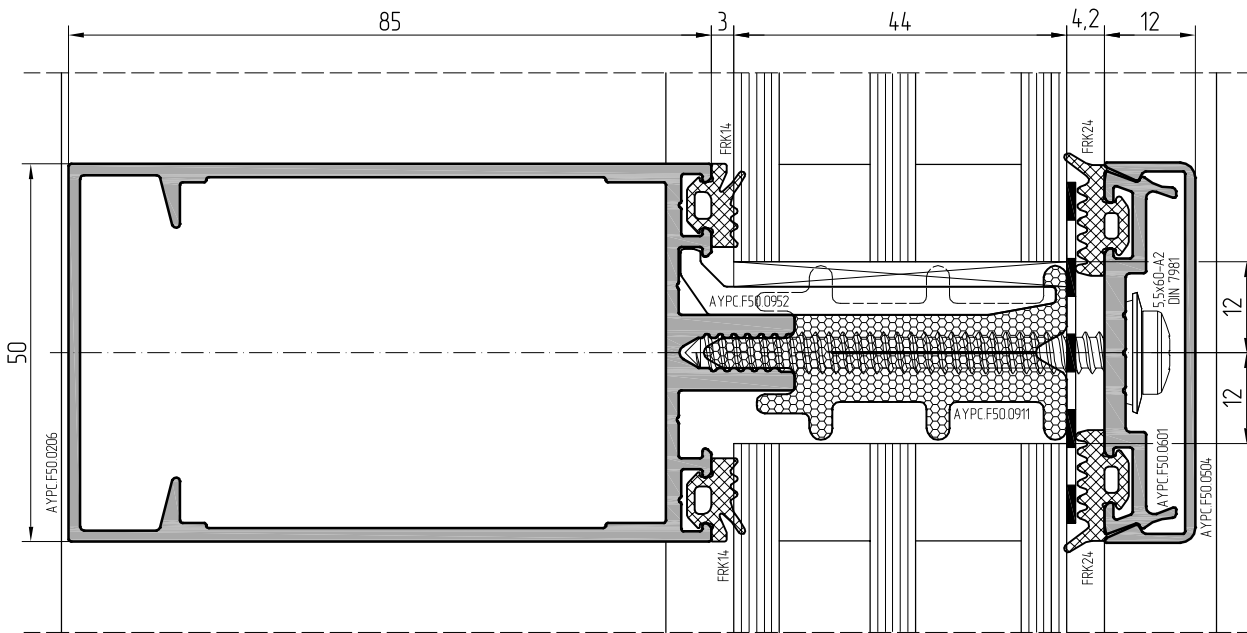
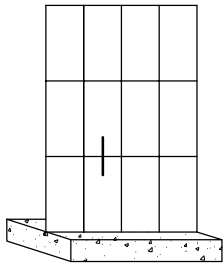



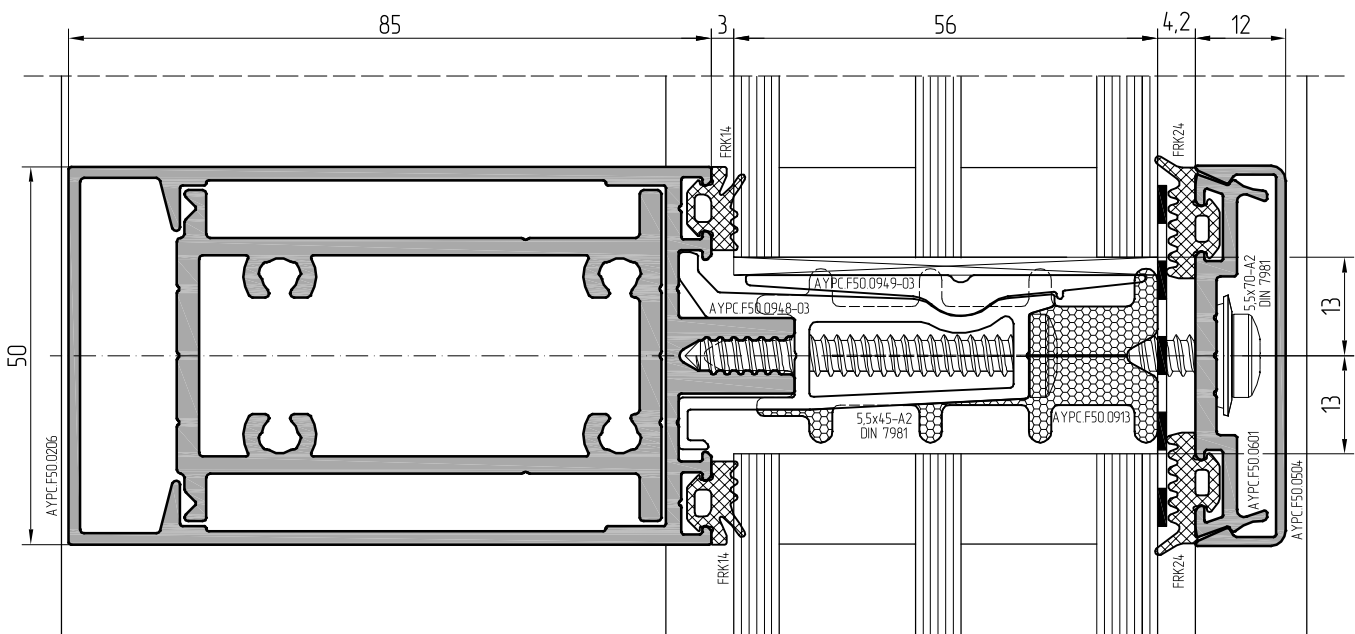
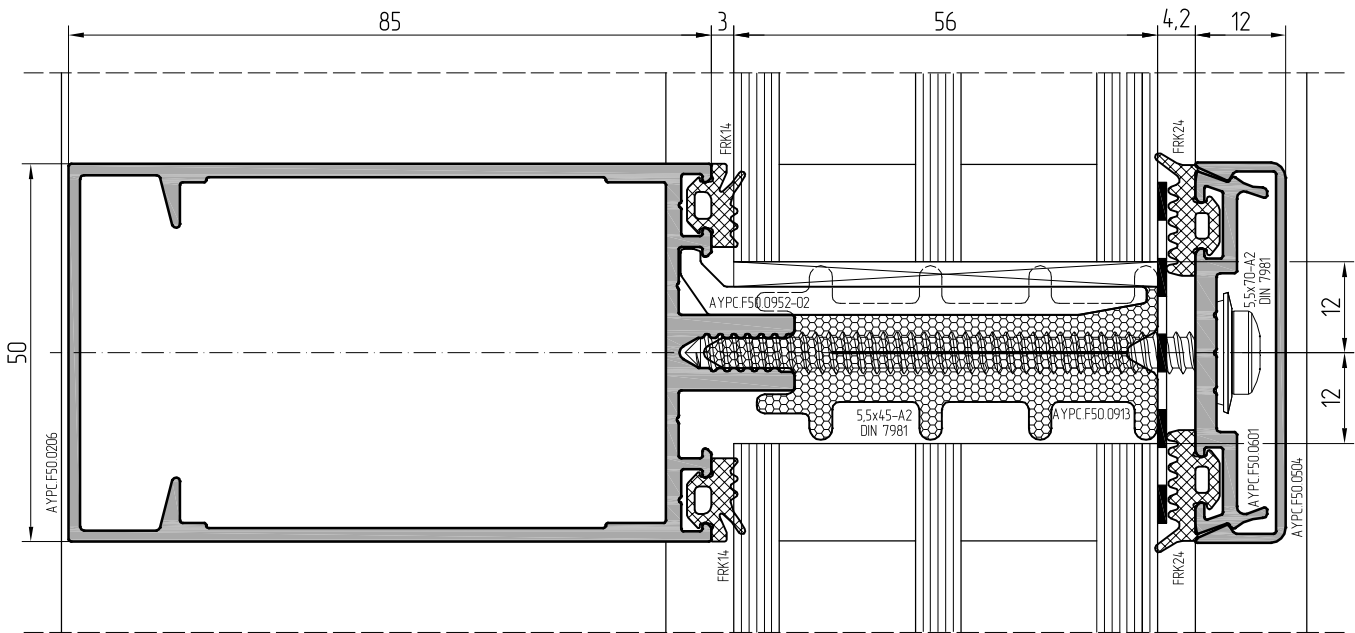
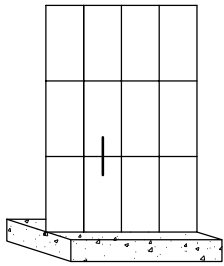

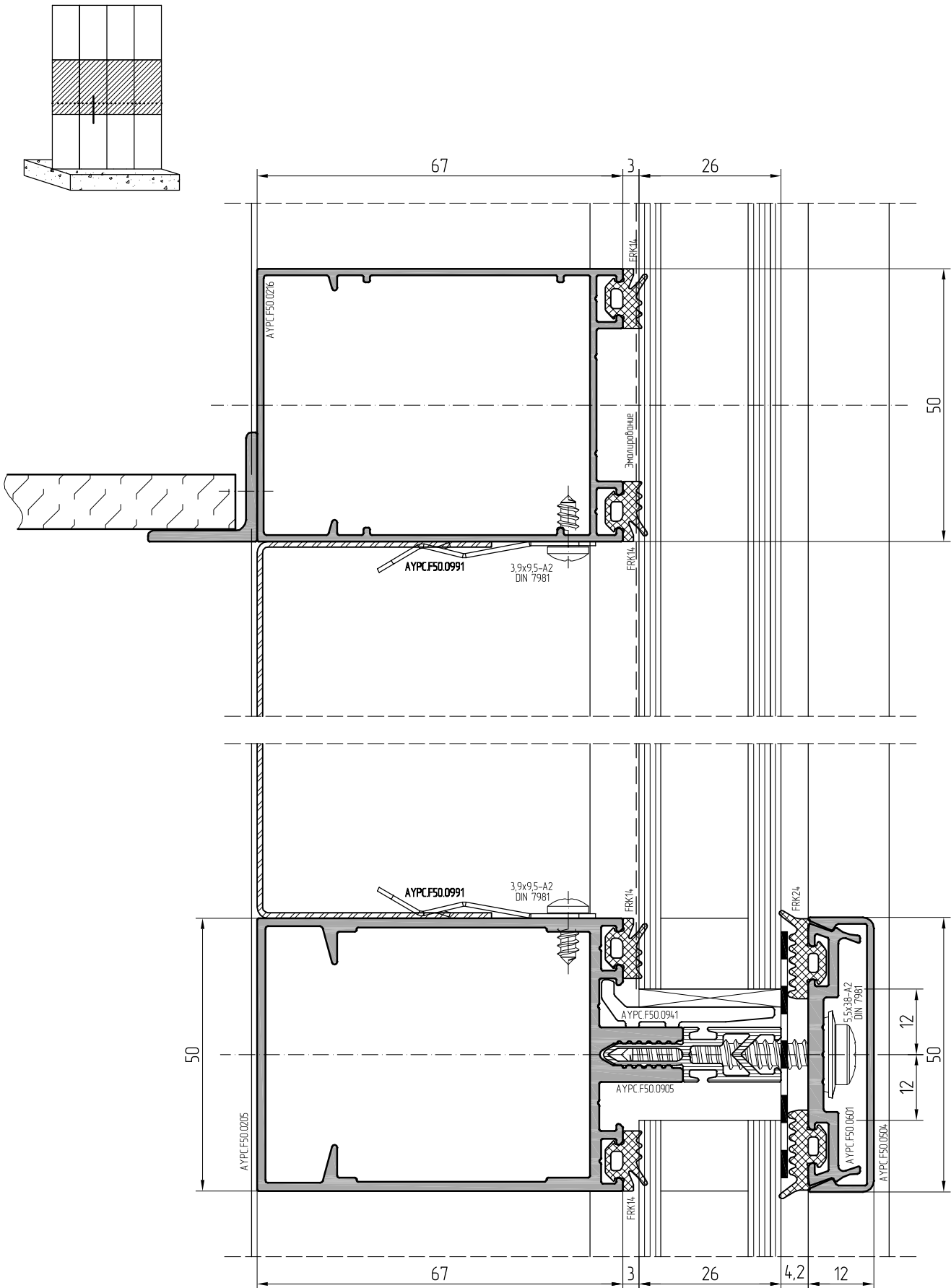

Scale 1:1

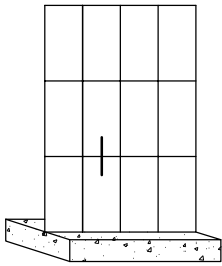

Variant

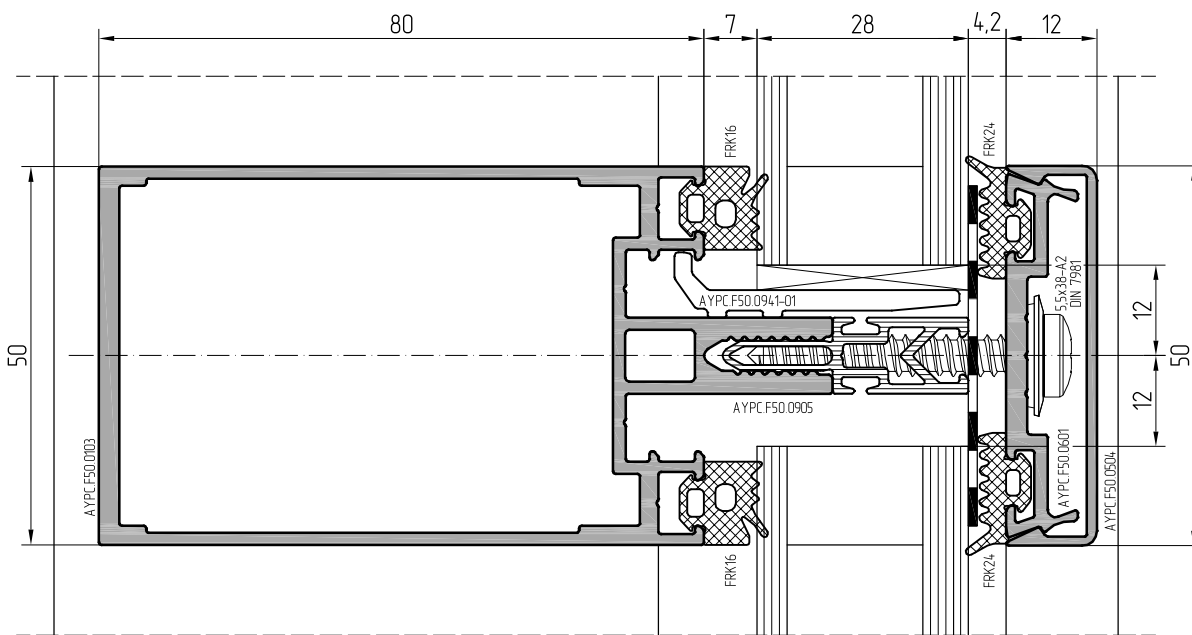
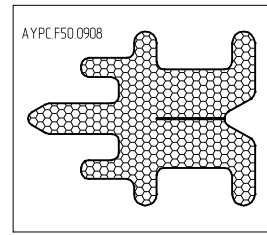

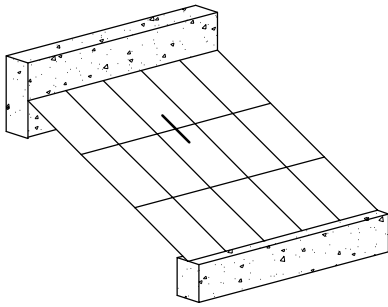

Variant

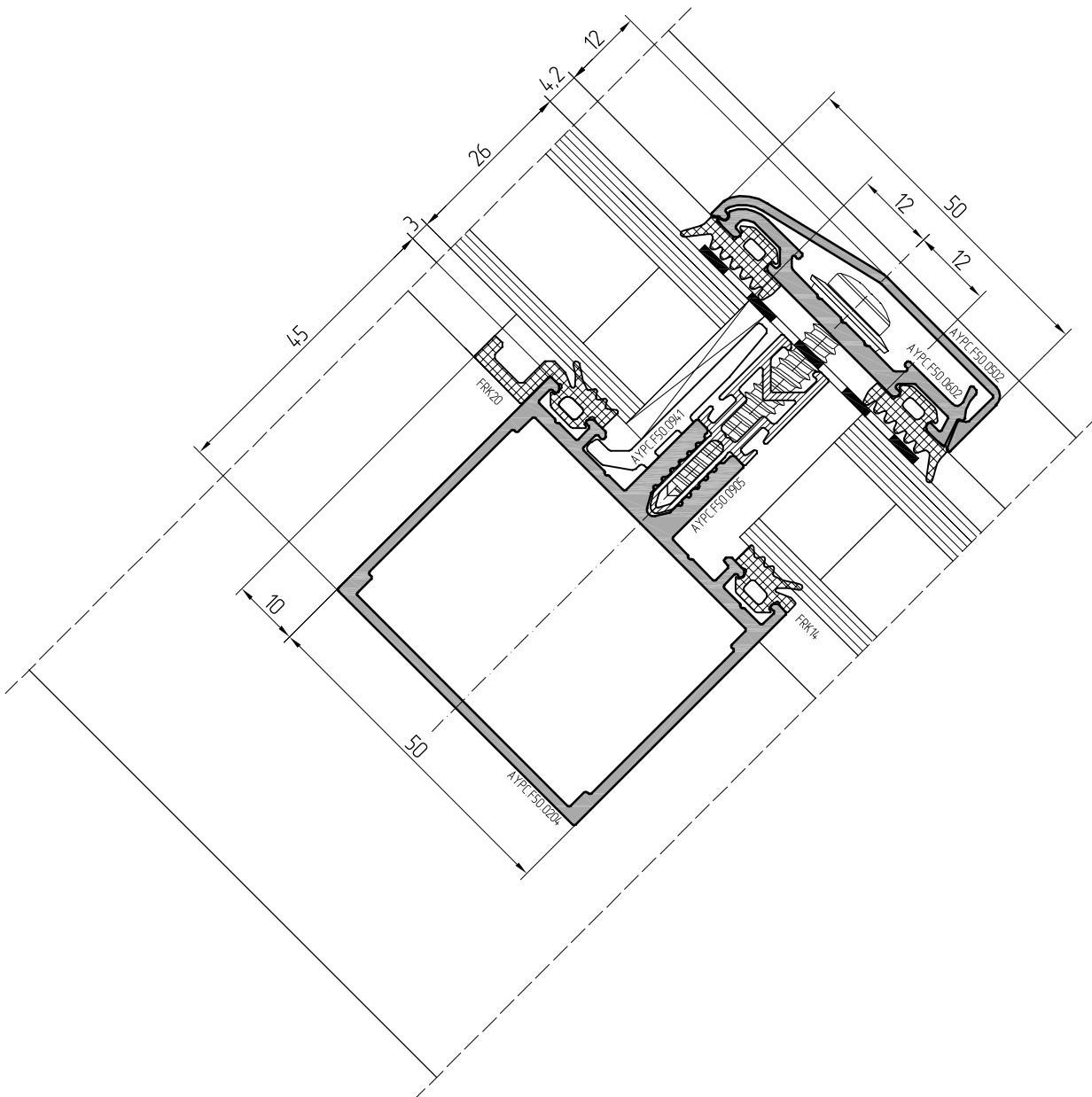
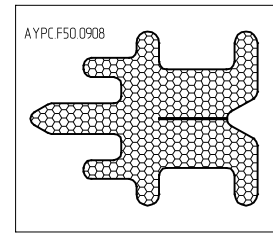











Scale 1:1

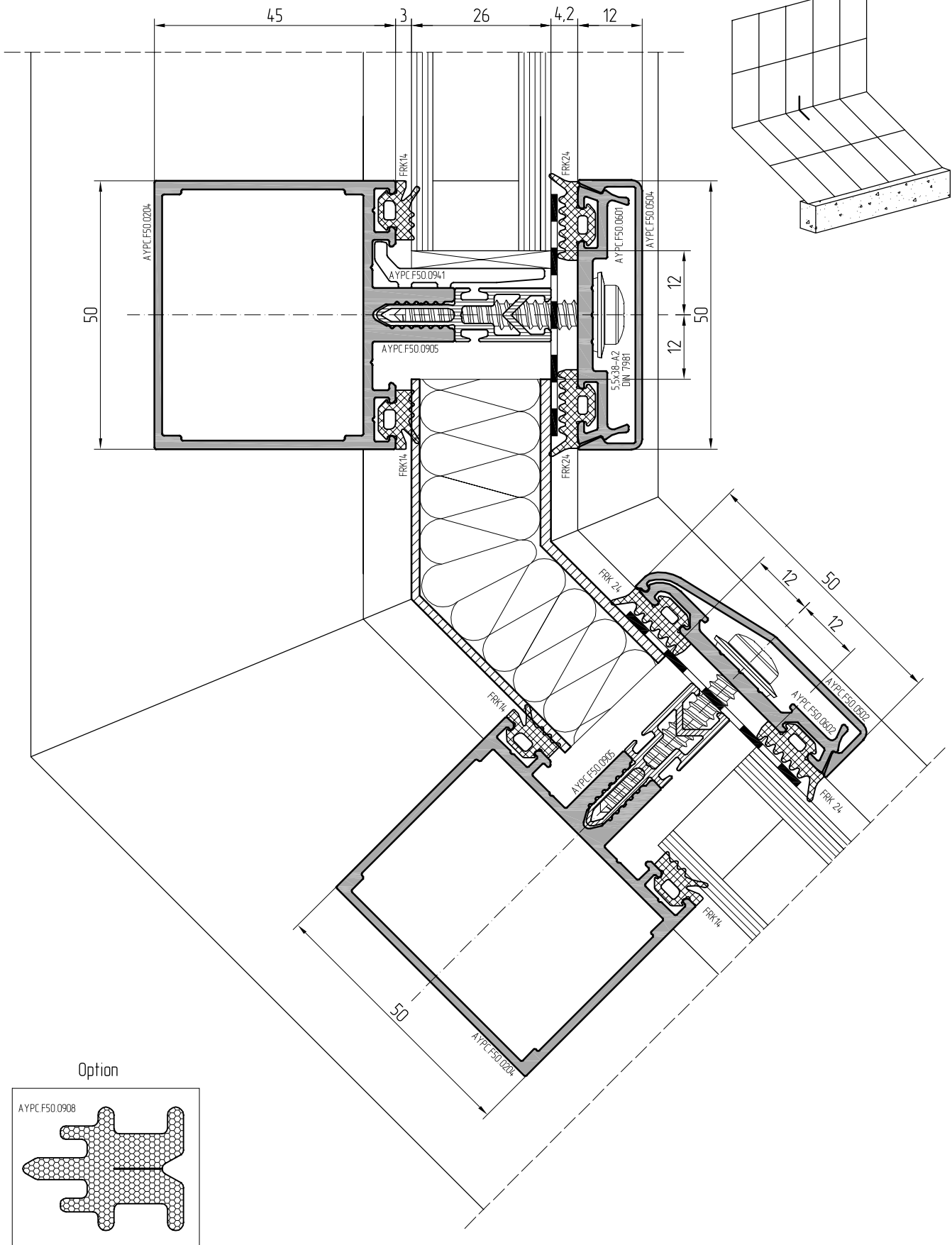

- 01
- 02
- 03
- 04
- 05
- 06
- 07
- 08
- 09
- 10
- 11
- 12
- 13

Scale 1:1

Option

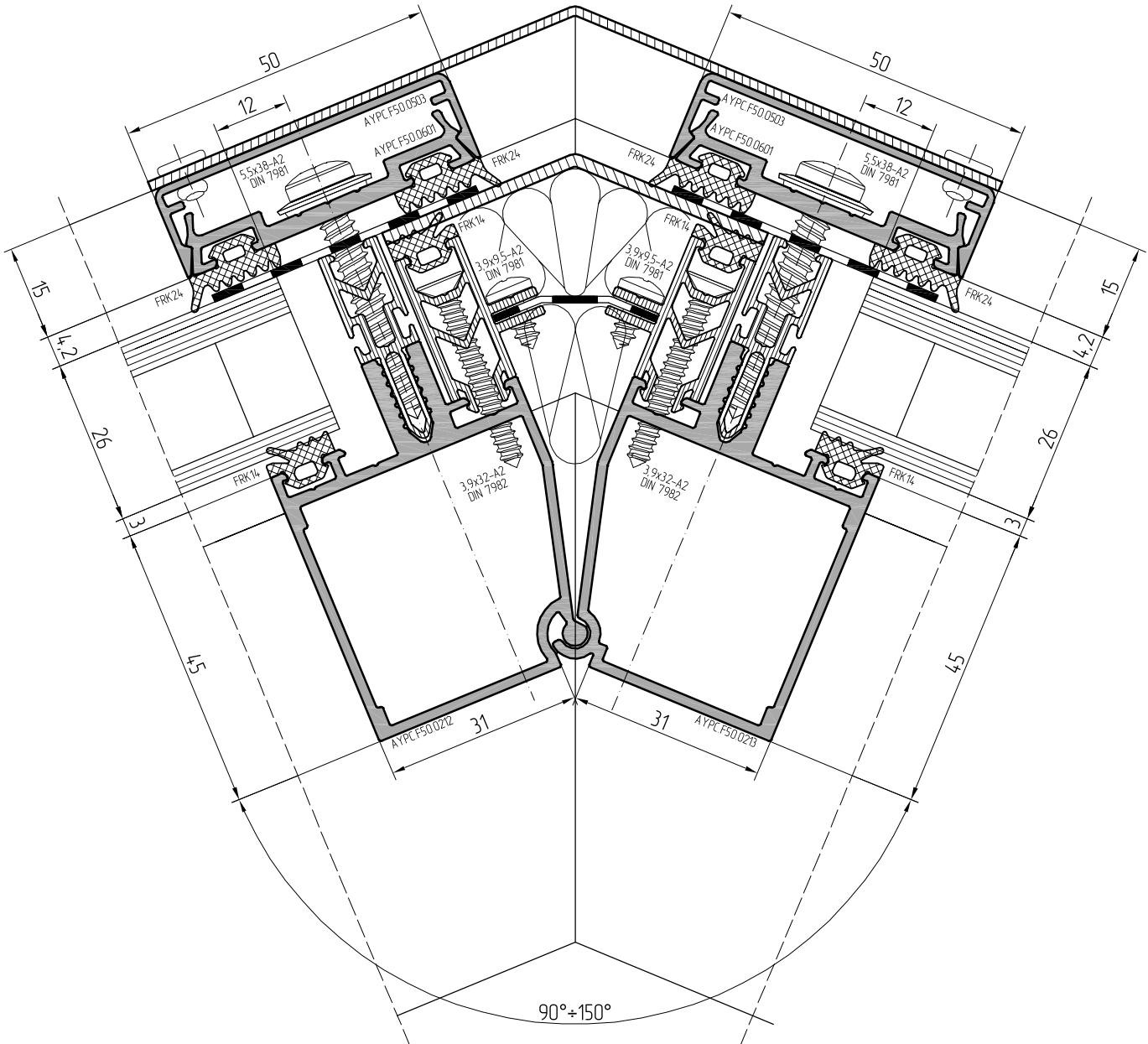
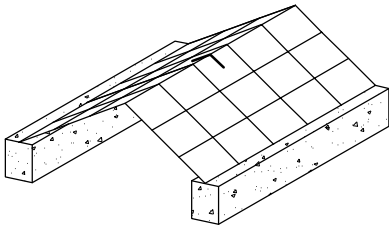
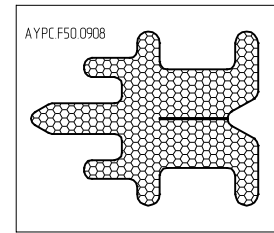

Scale 1:1

Option

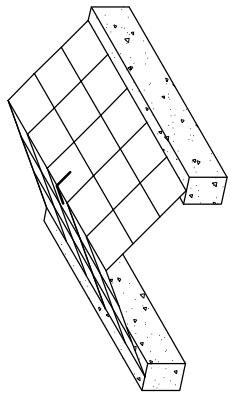
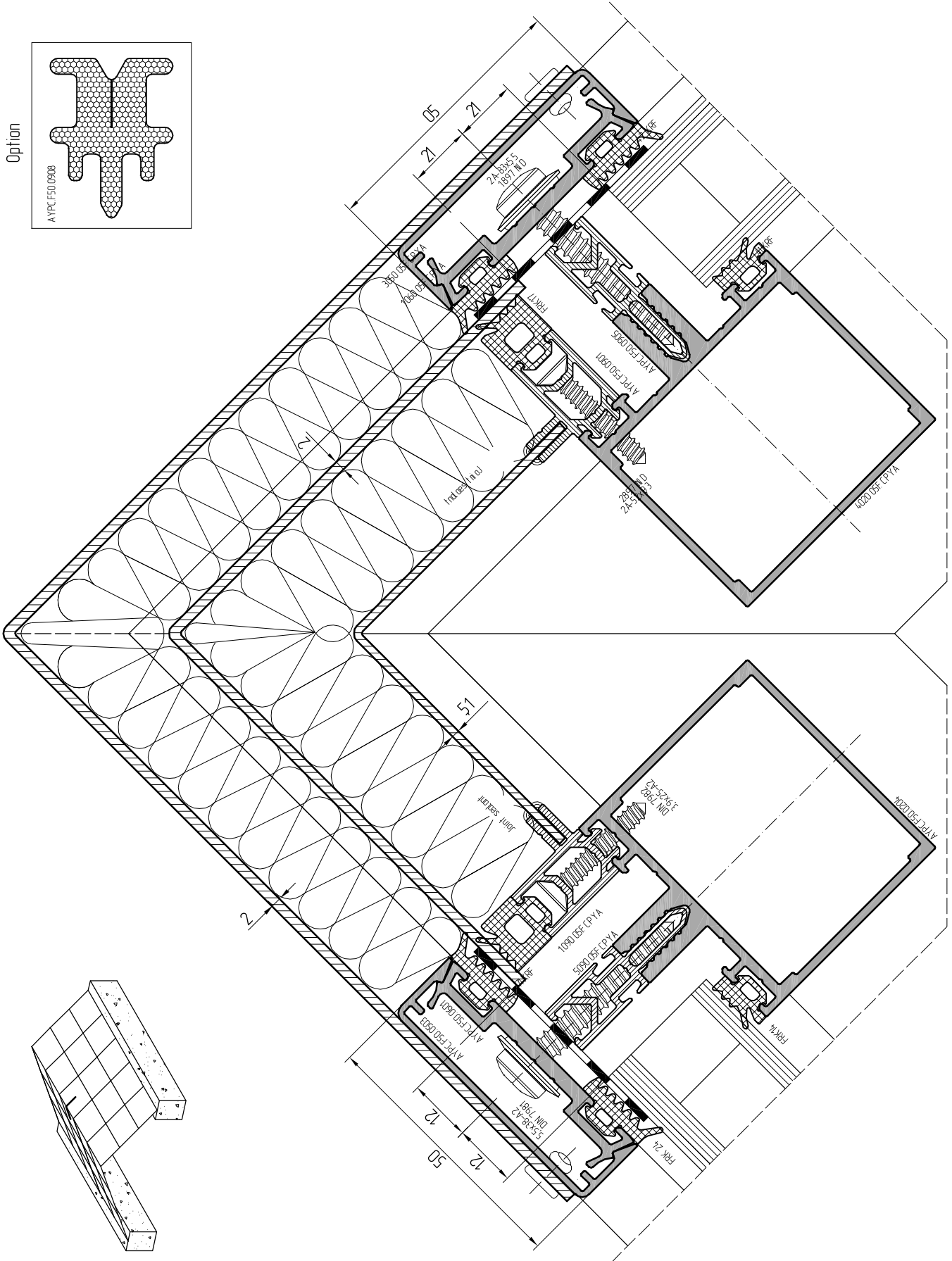
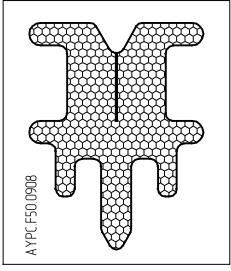

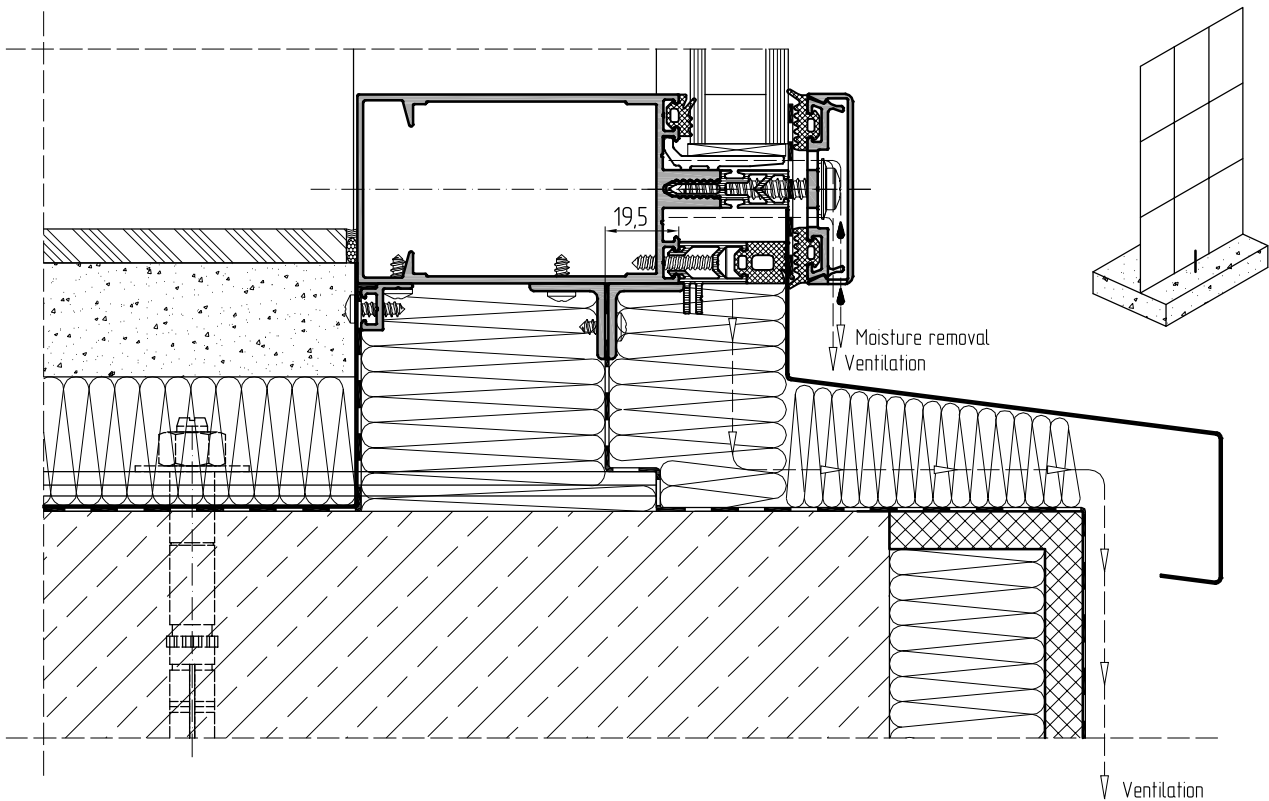
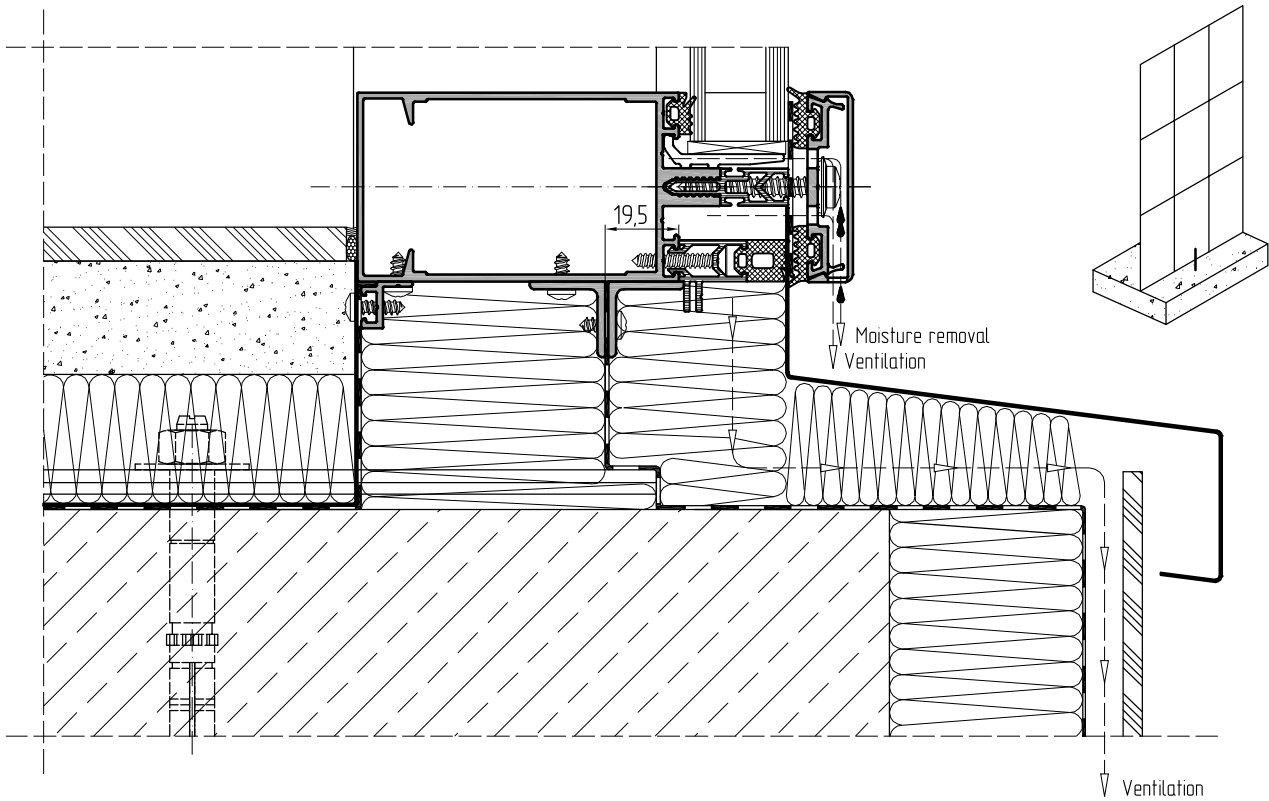

Scale 12

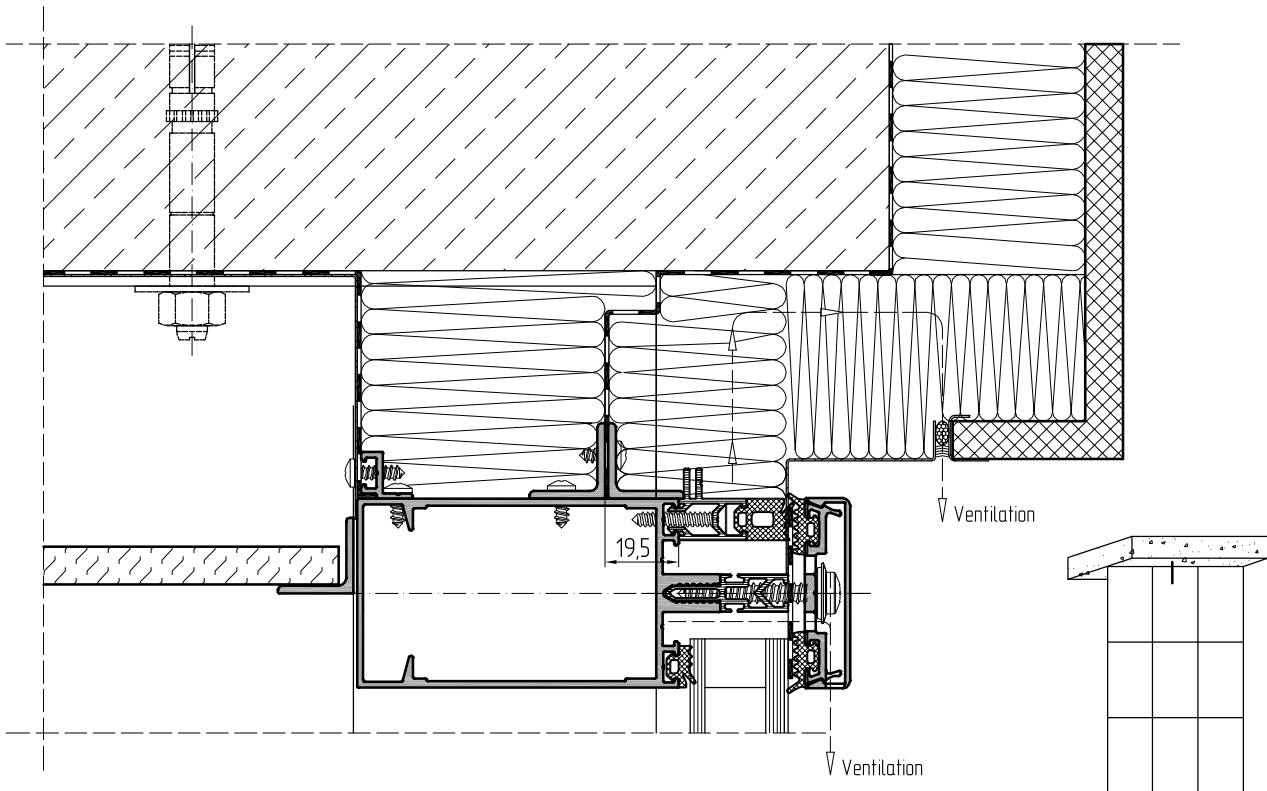
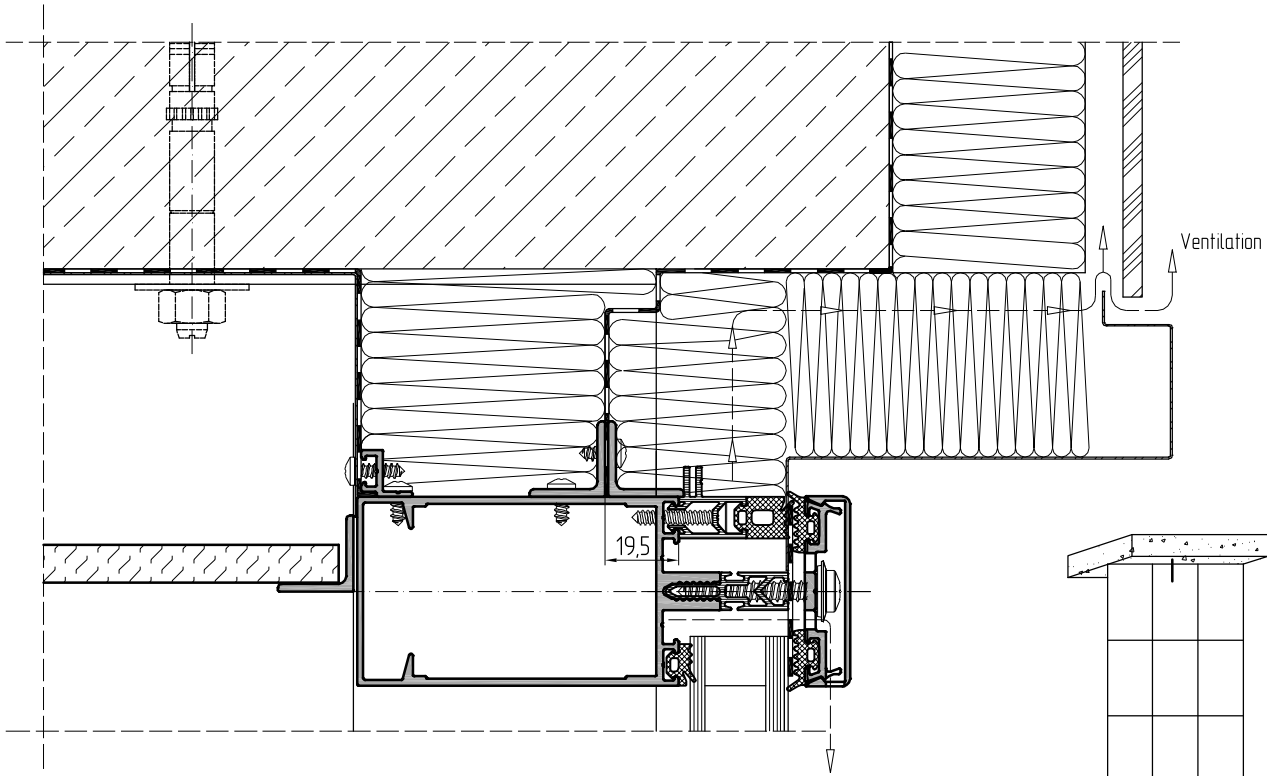



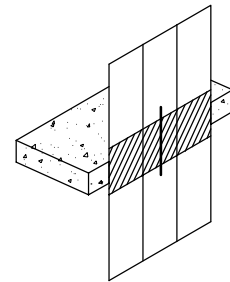
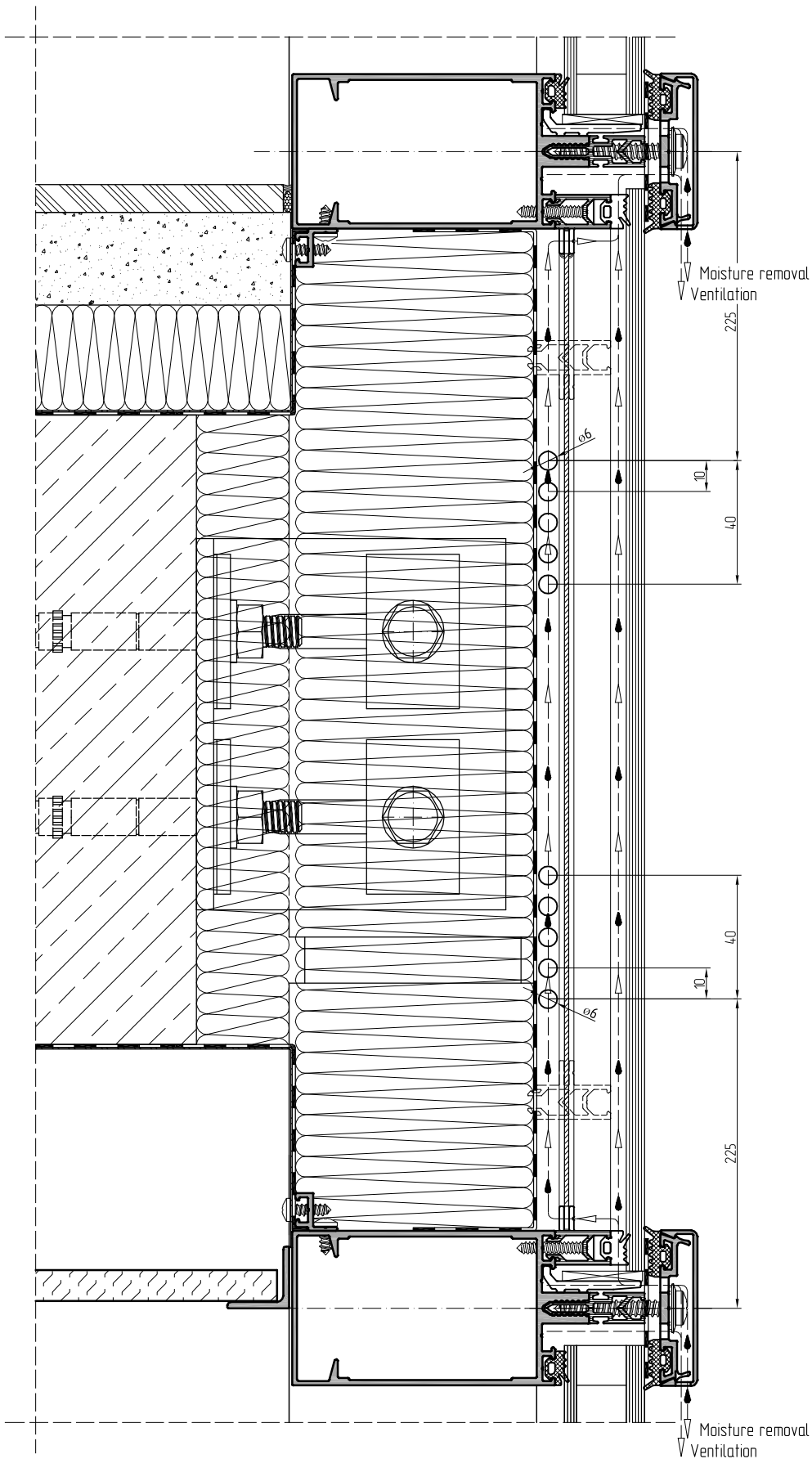



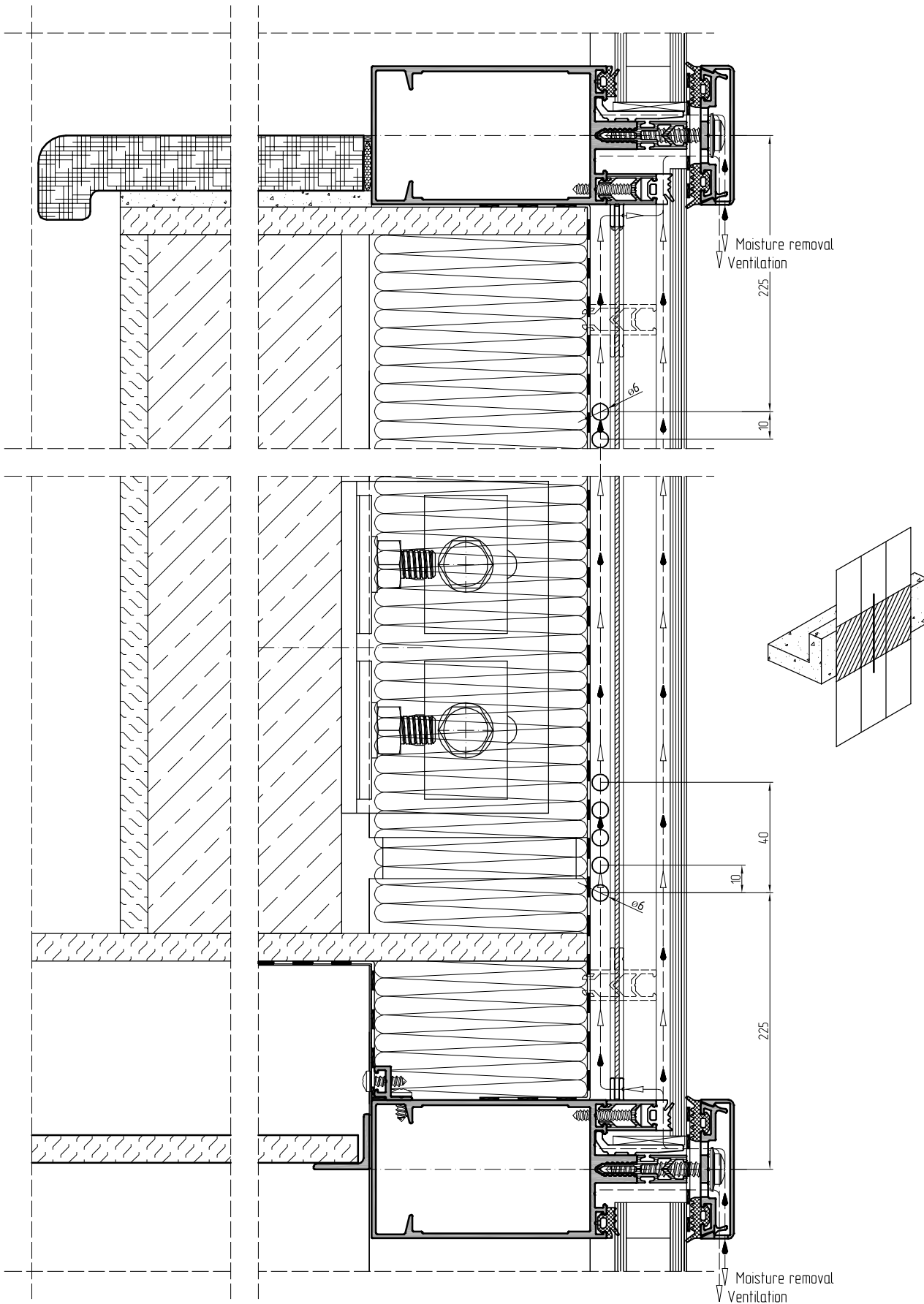

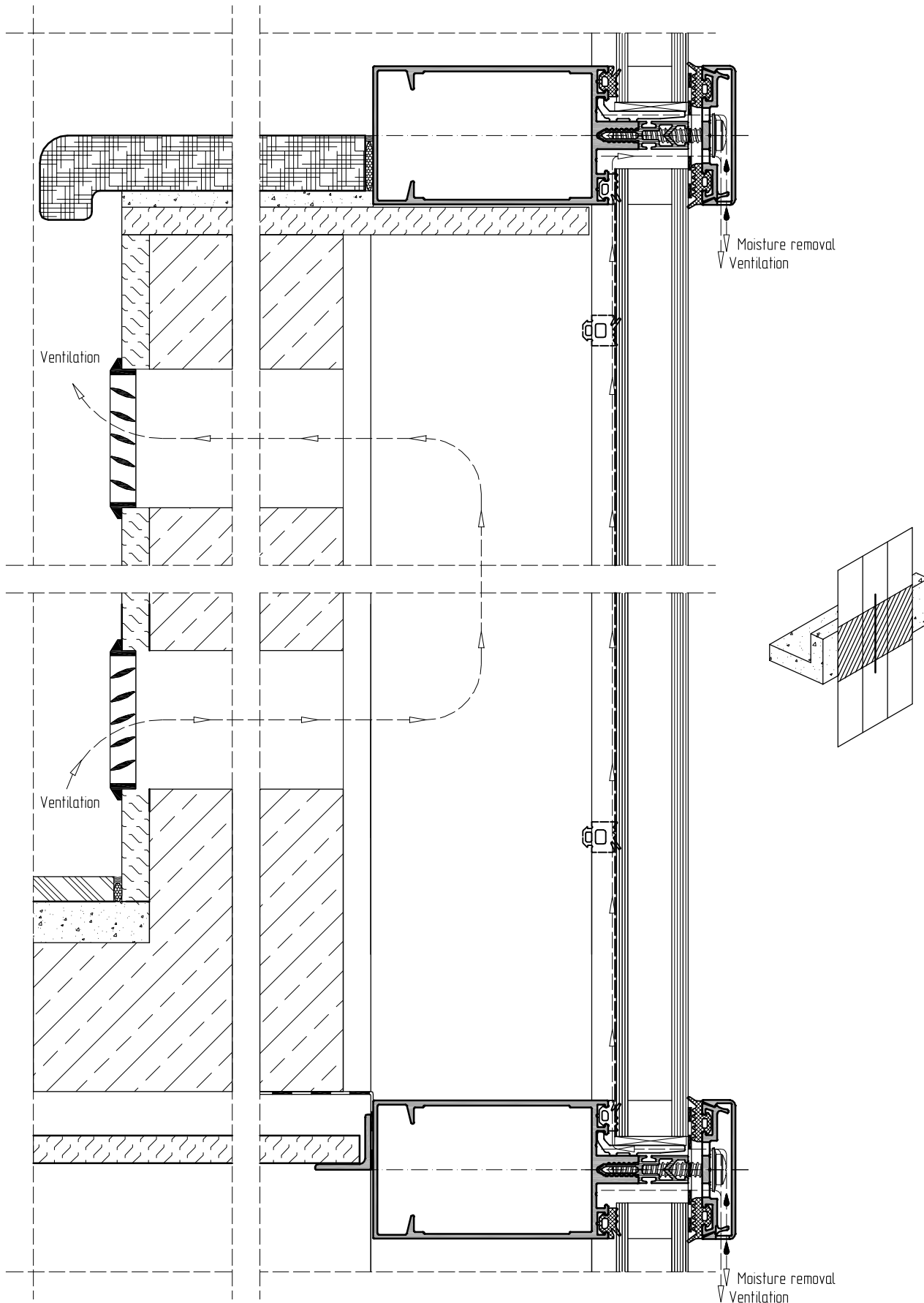

Scale 1:2

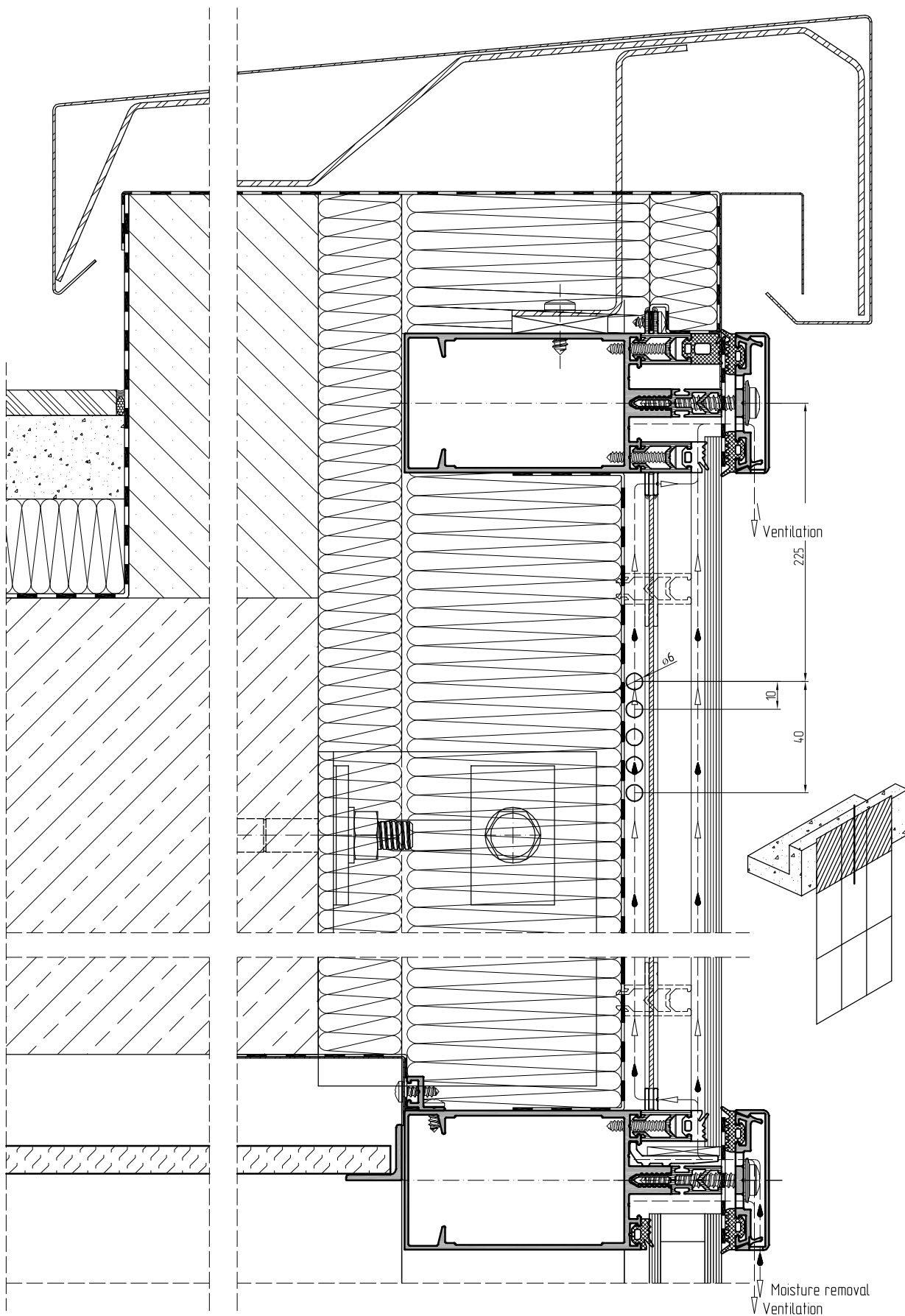

- 01
- 02
- 03
- 04
- 05
- 06
- 07
- 08
- 09
- 10
- 11
- 12
- 13

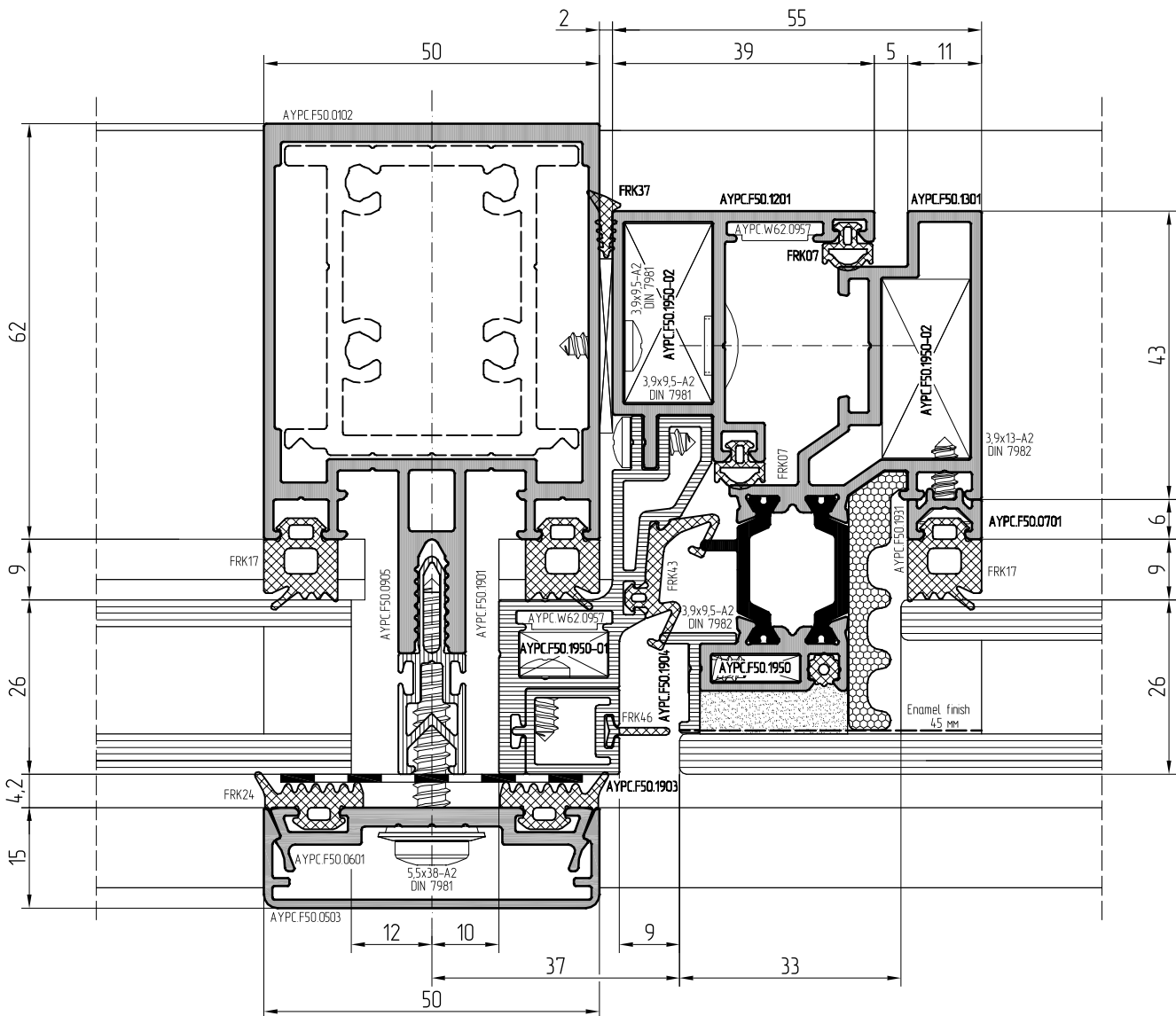
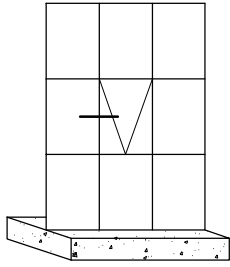

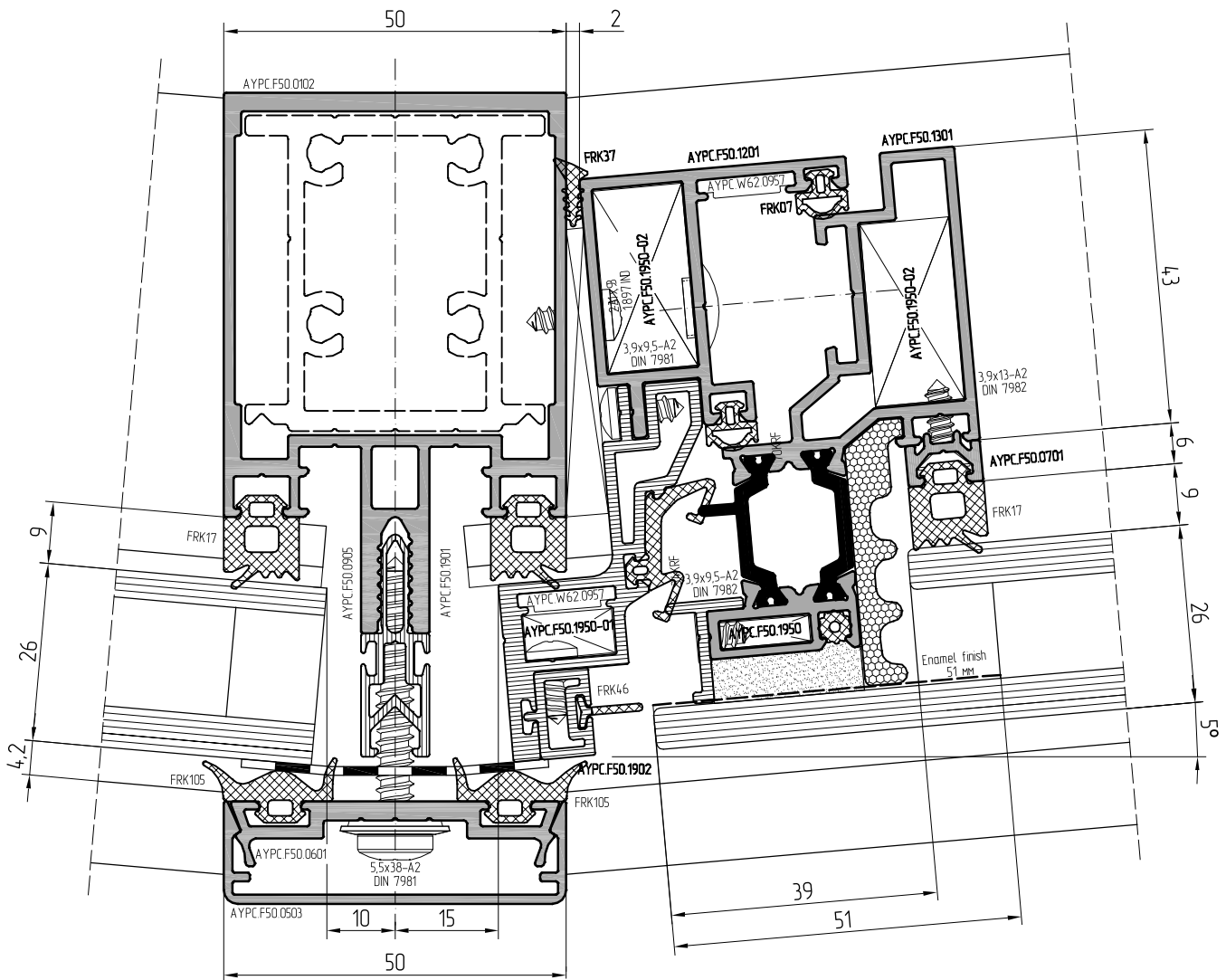
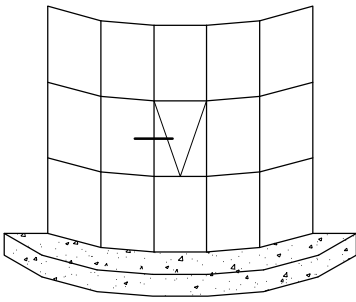

- 01
- 02
- 03
- 04
- 05
- 06
- 07
- 08
- 09
- 10
- 11
- 12
- 13

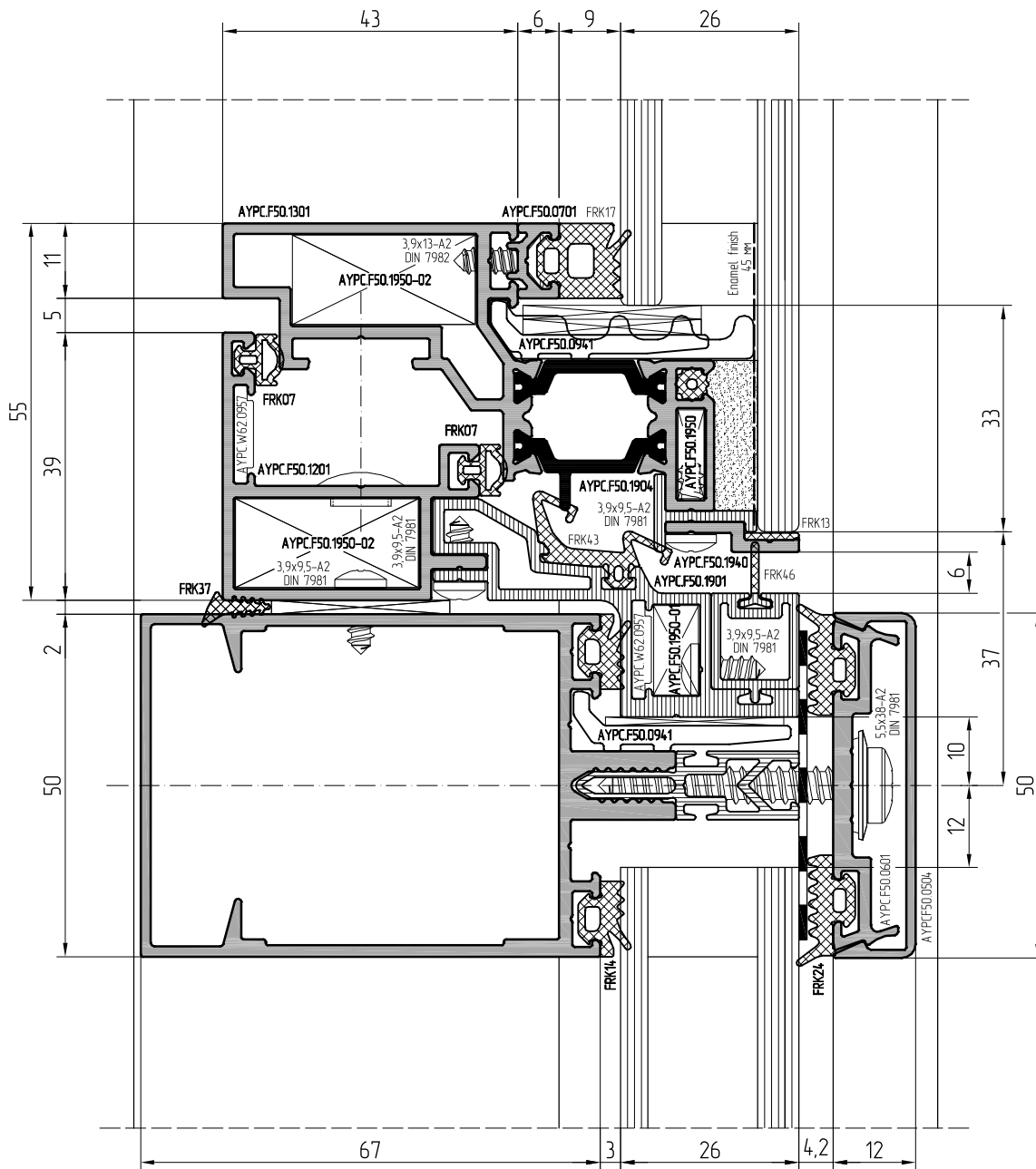
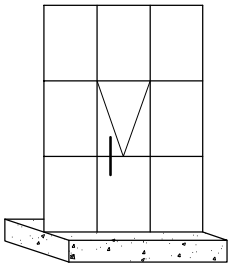



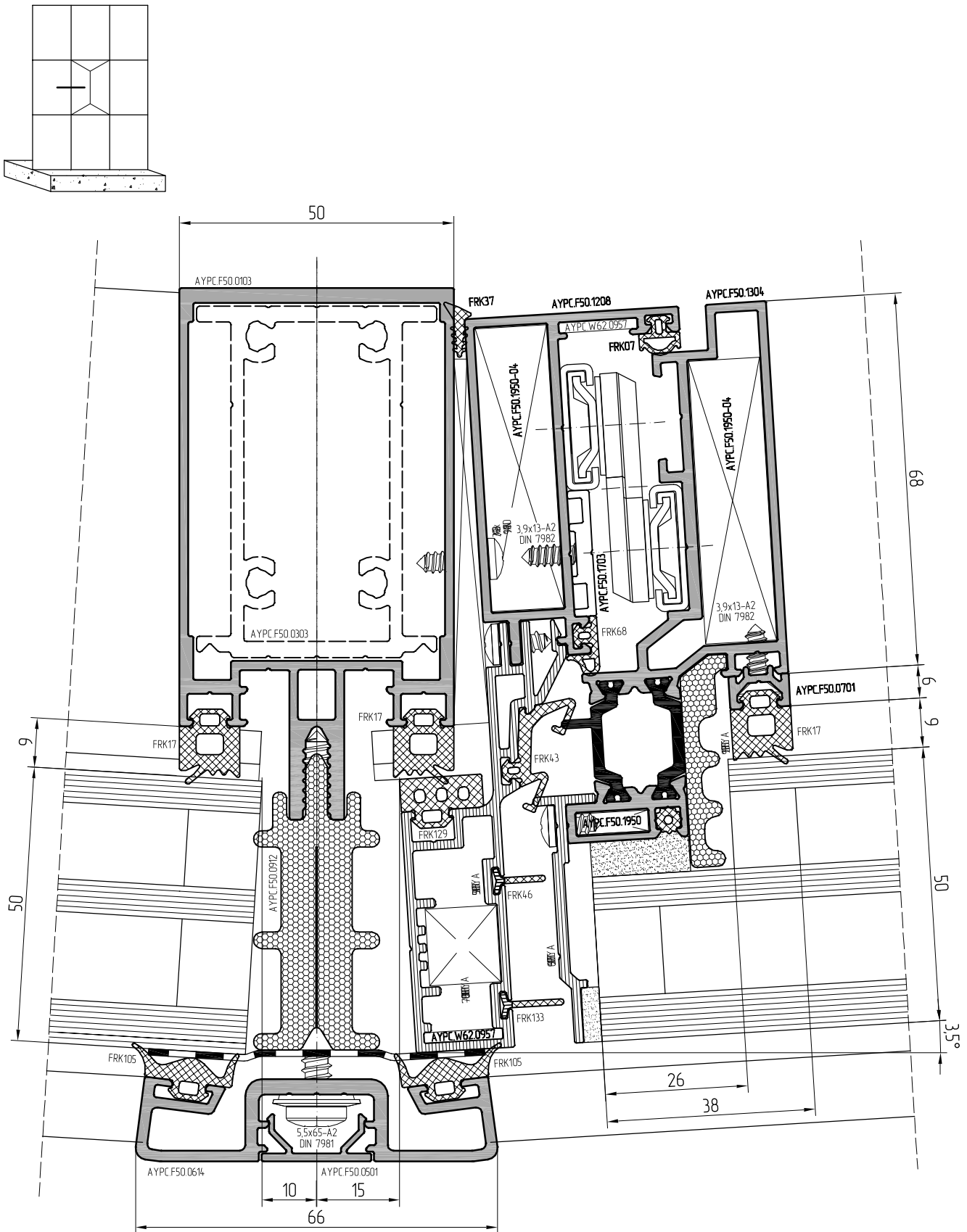





Scale 1:1

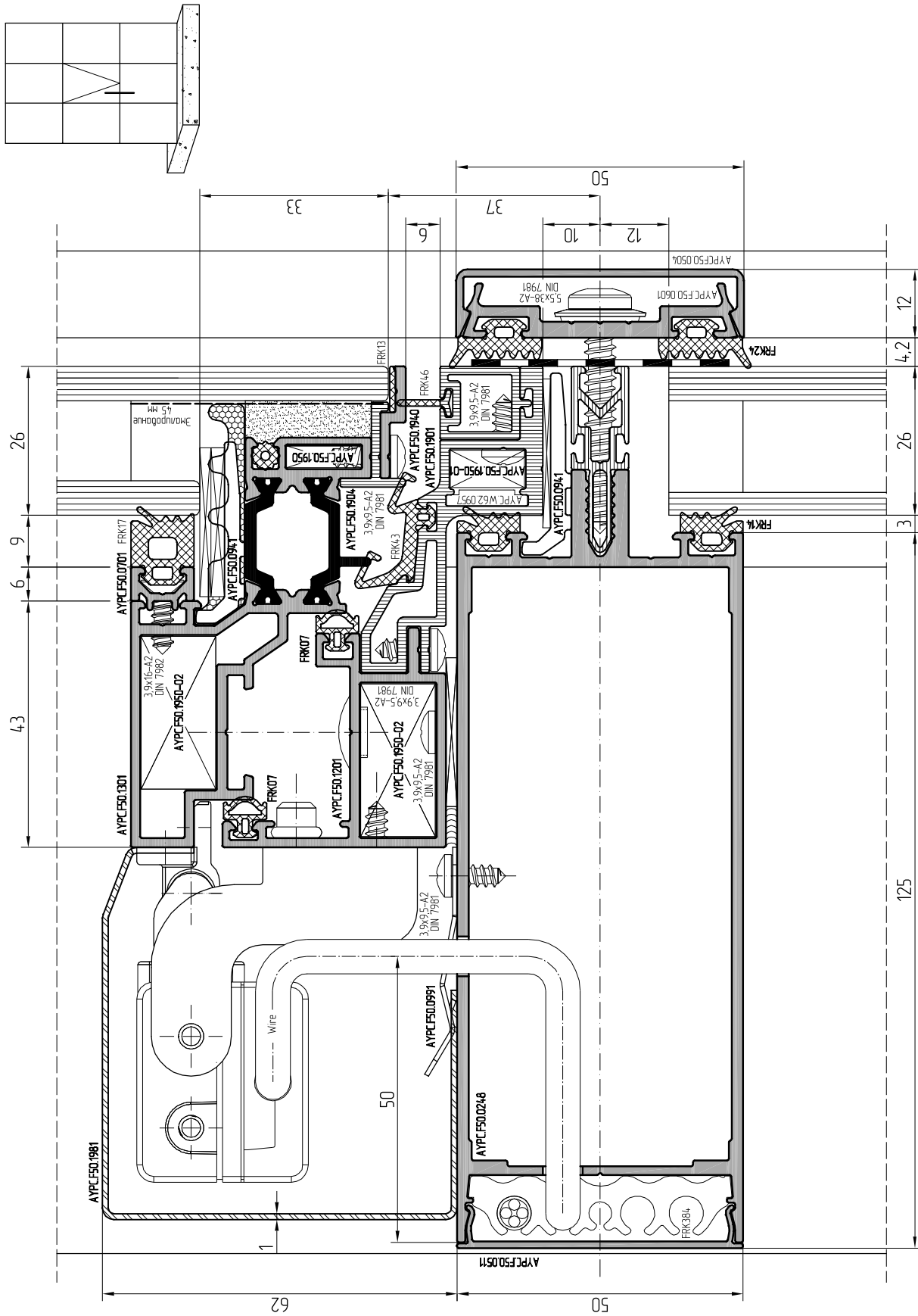



Scale 1:1

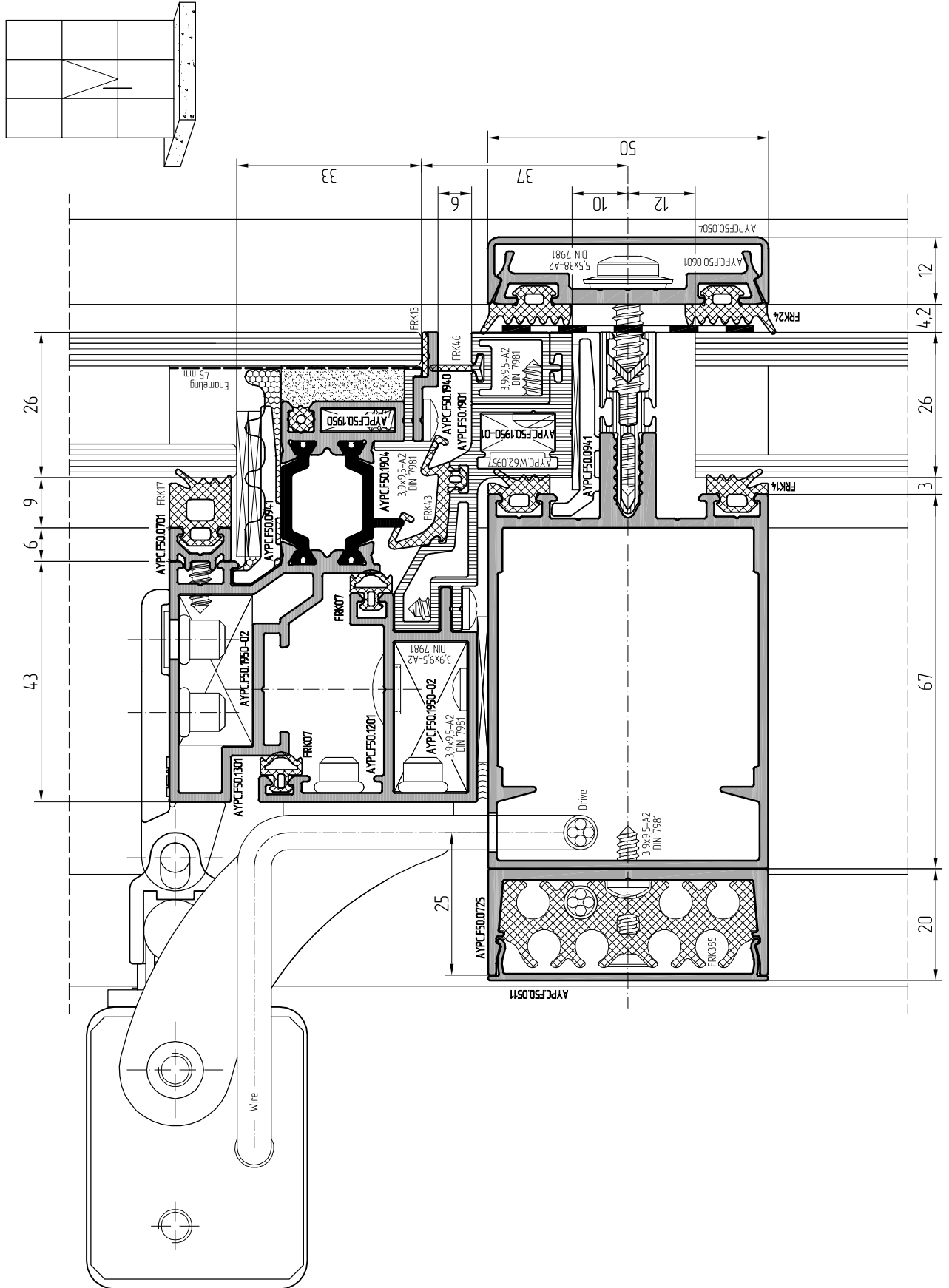

Scale 1:1

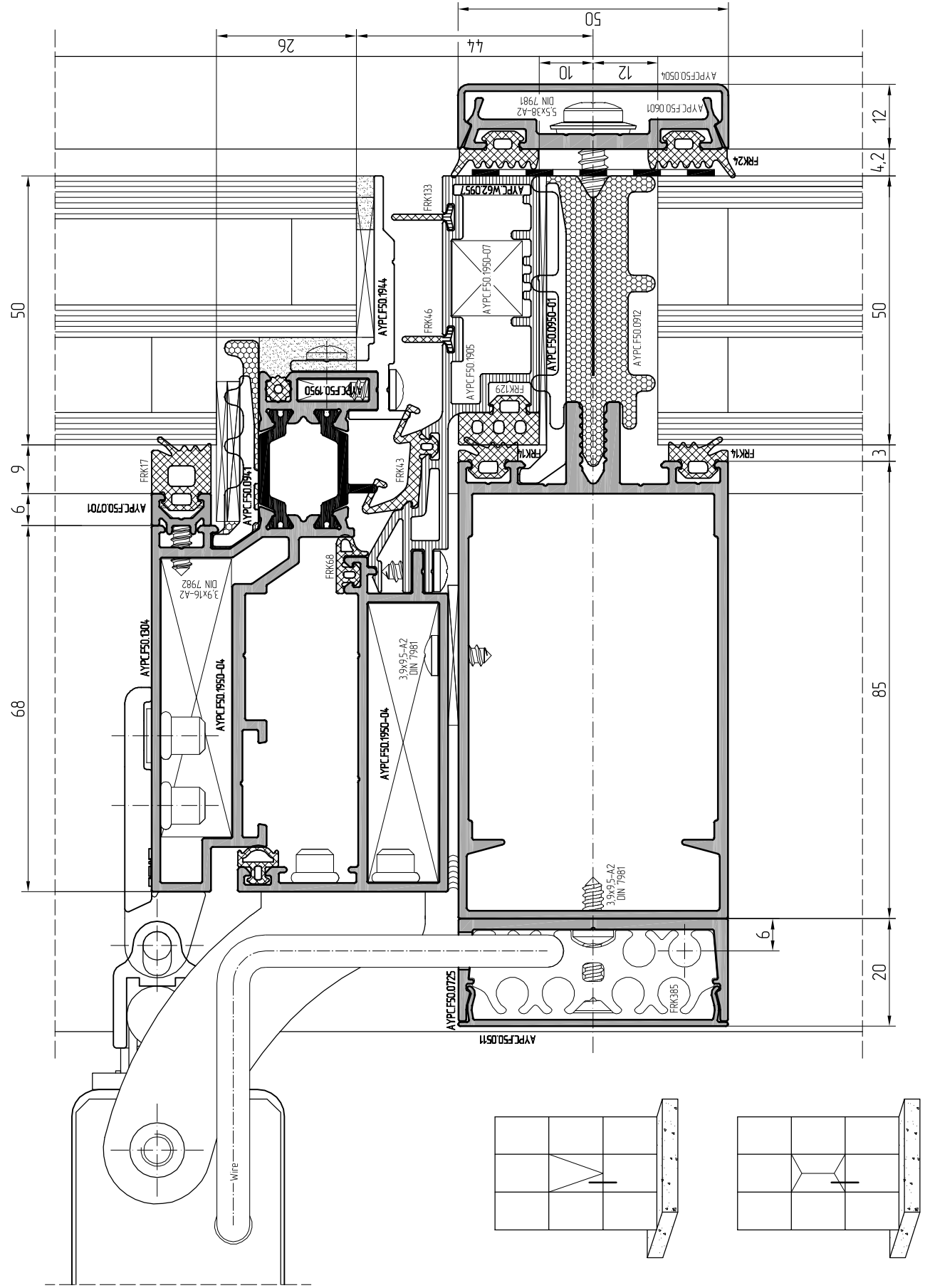



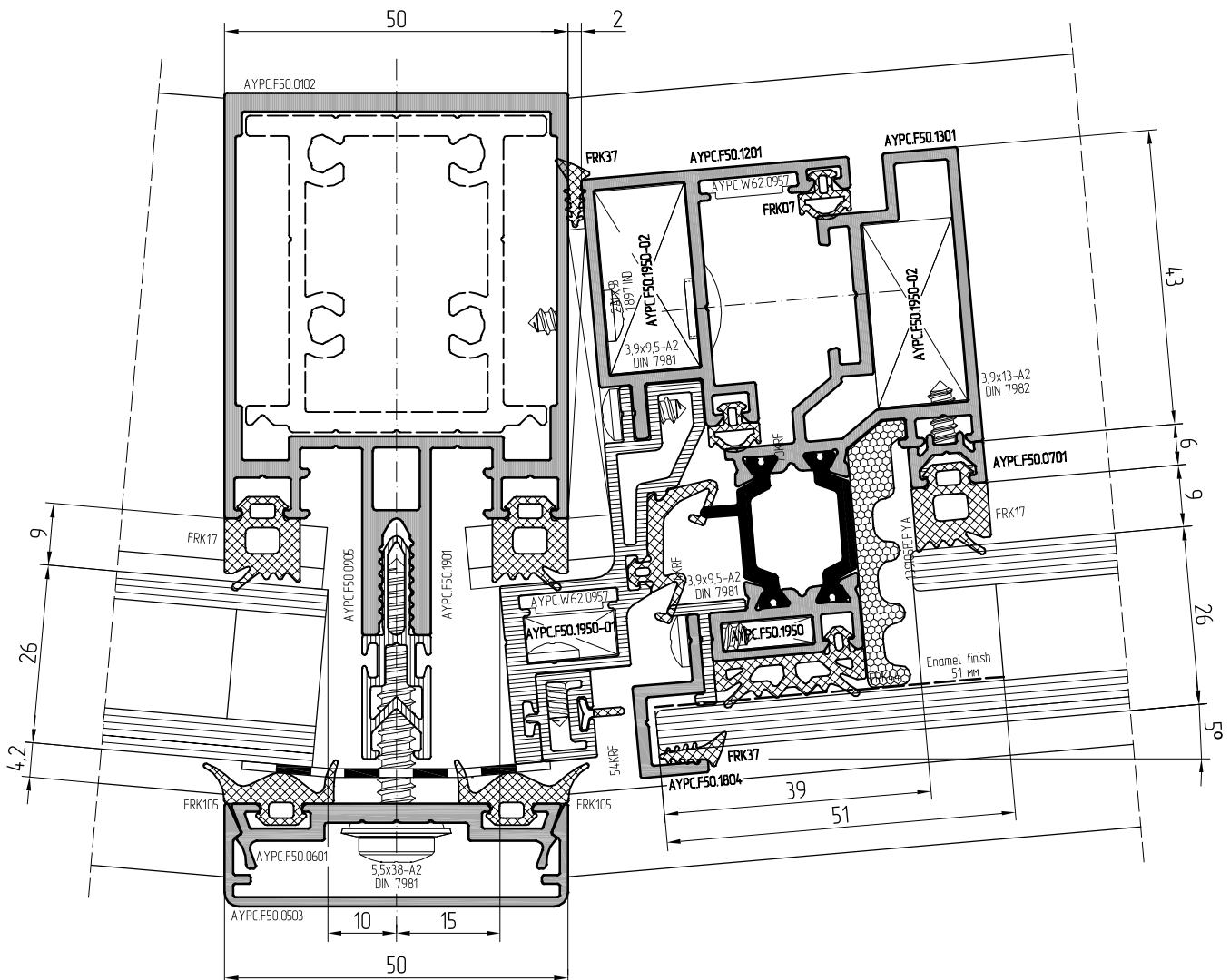
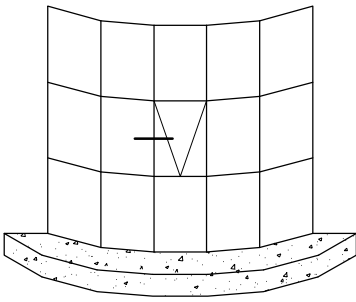

- 01
- 02
- 03
- 04
- 05
- 06
- 07
- 08
- 09
- 10
- 11
- 12
- 13

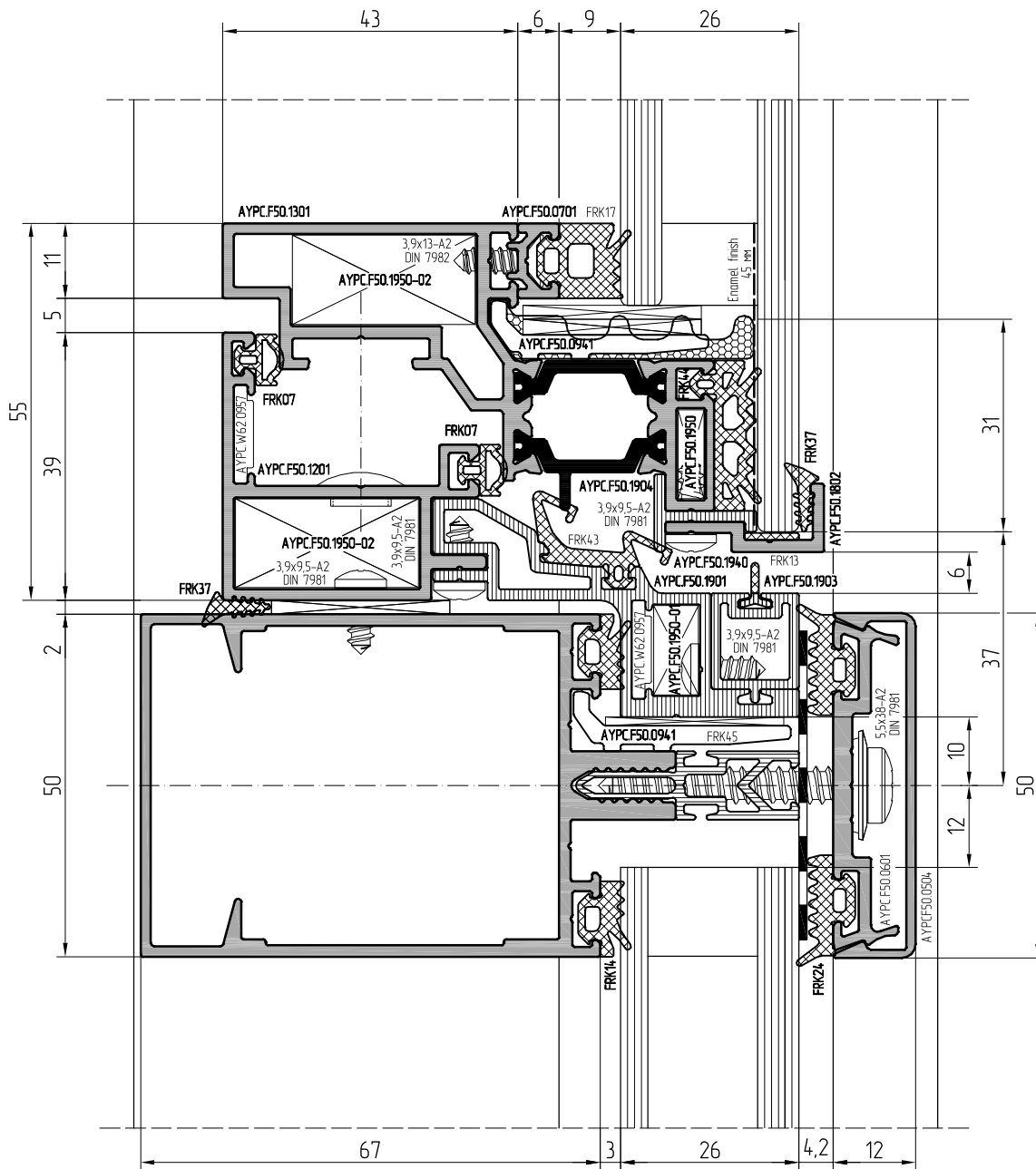
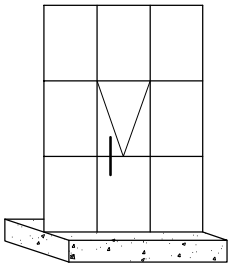





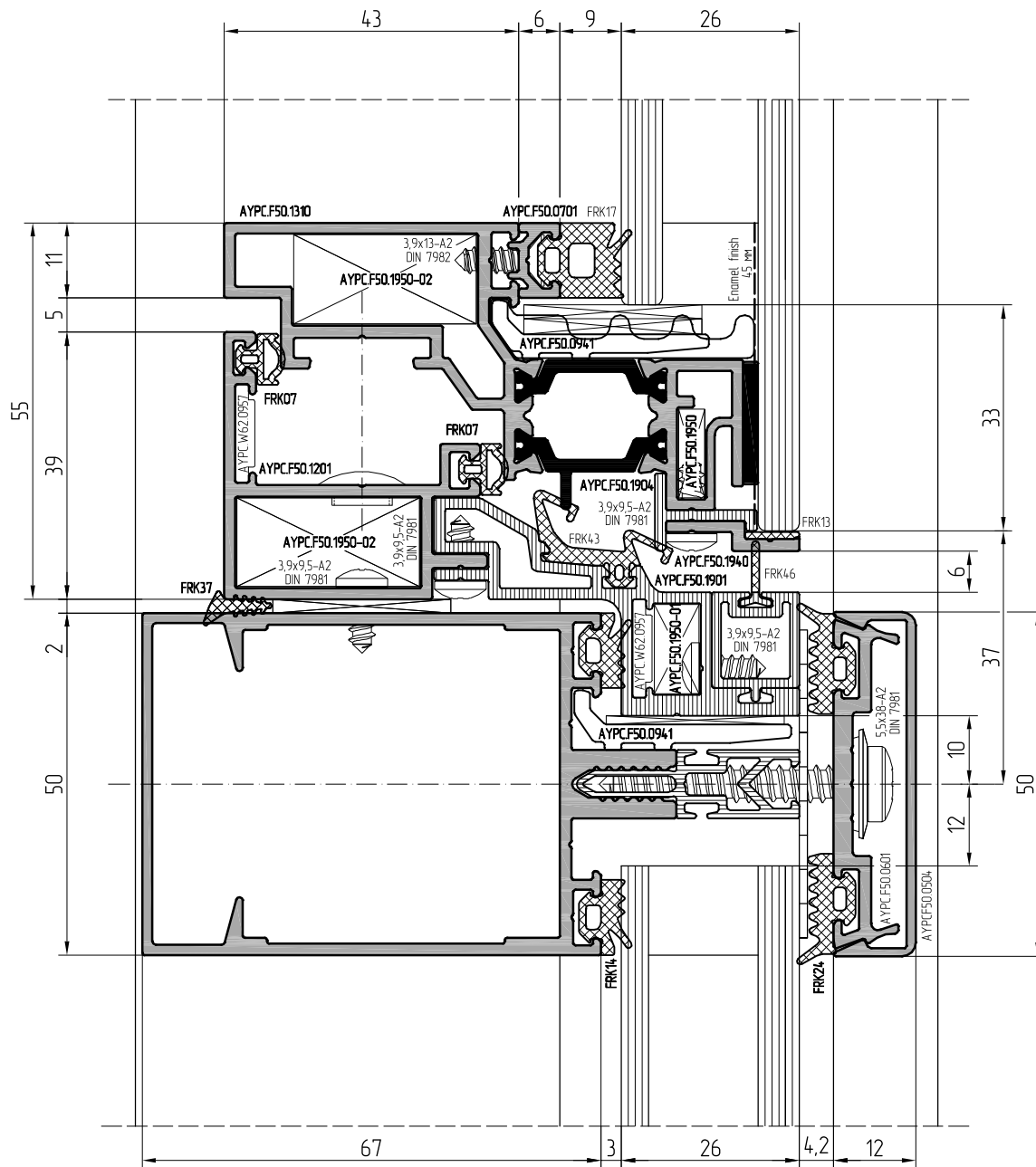
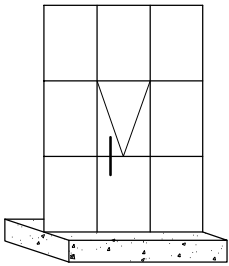

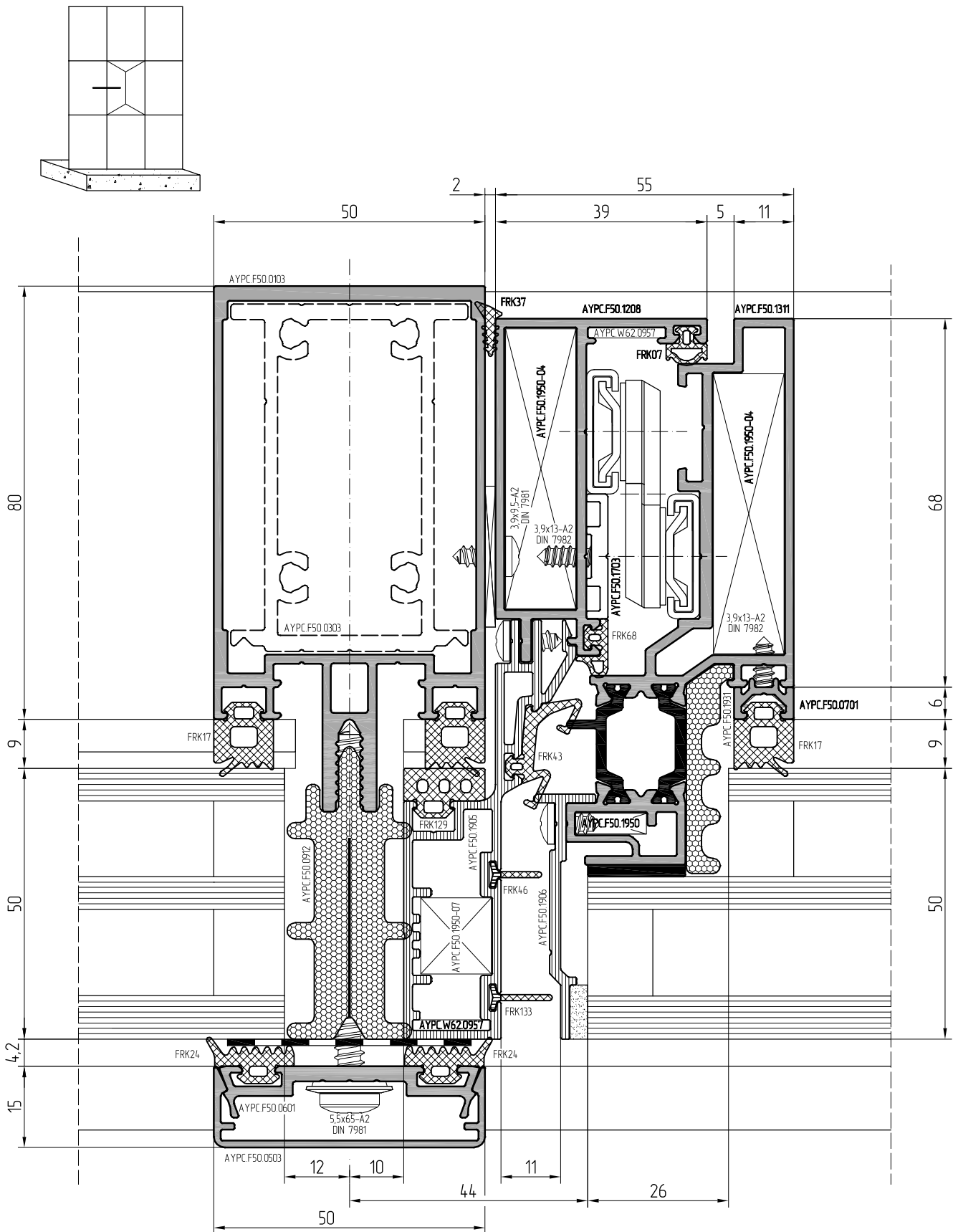

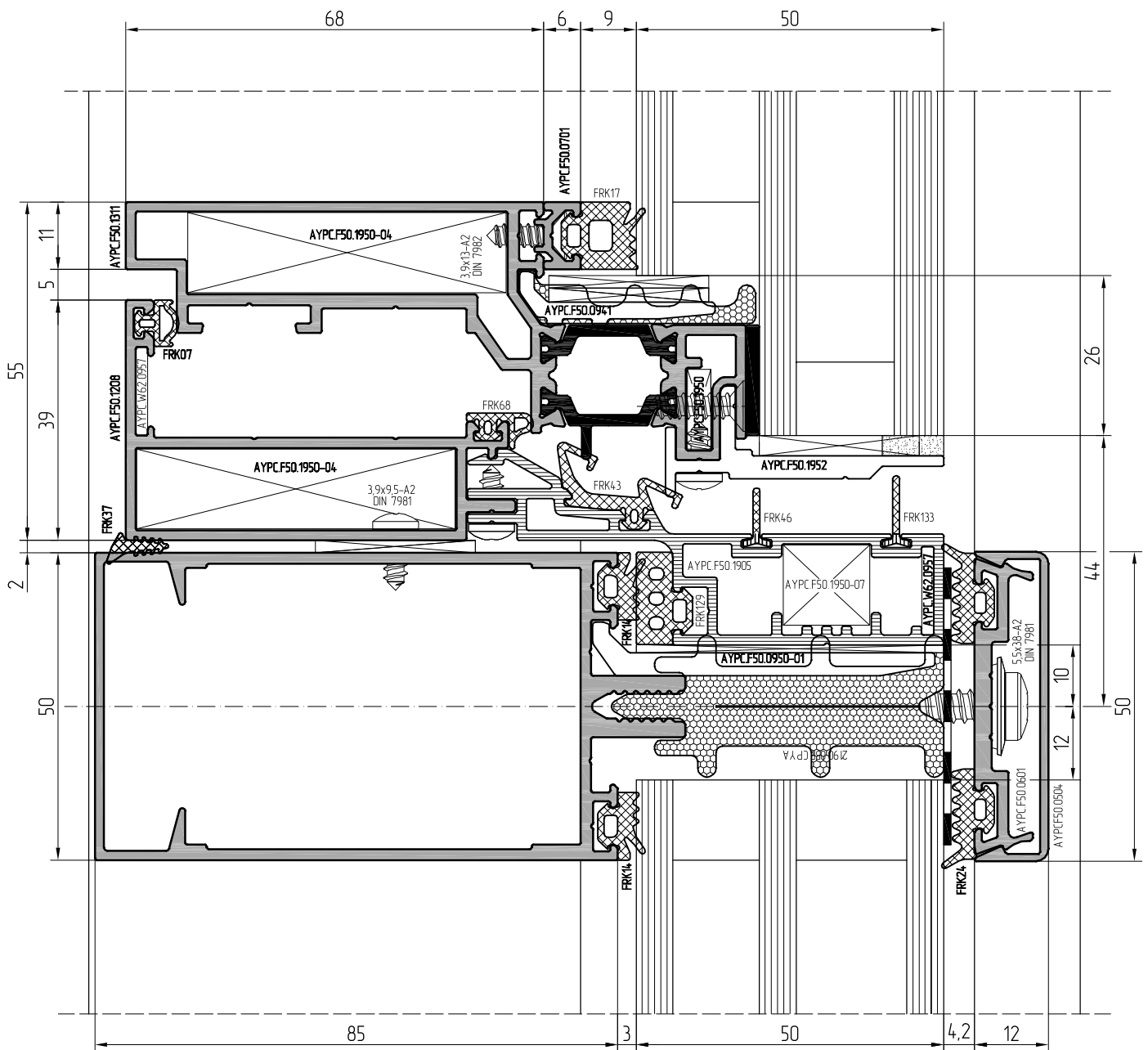
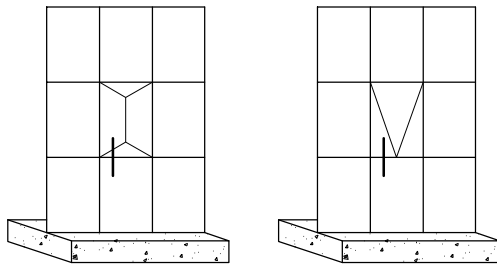



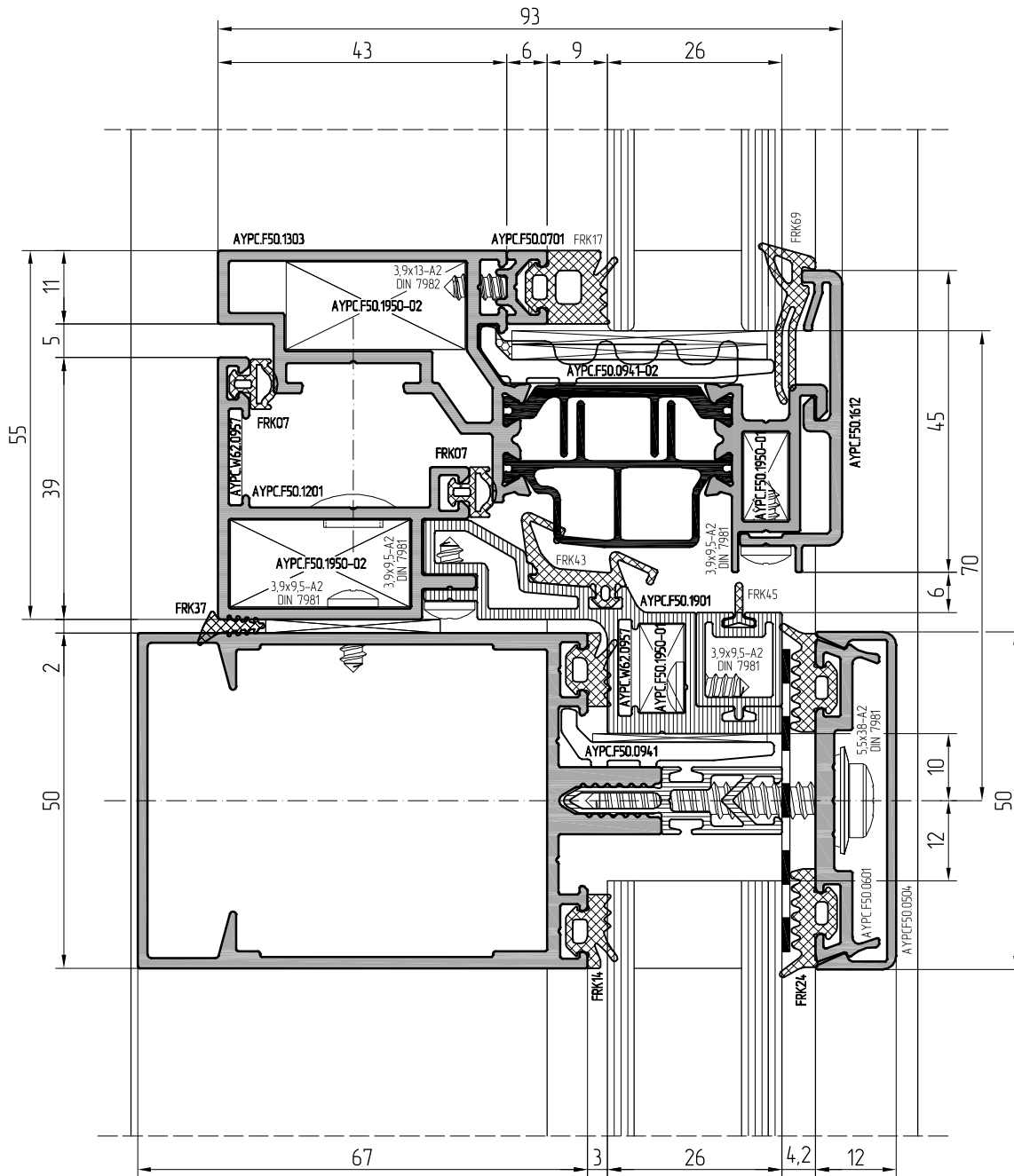
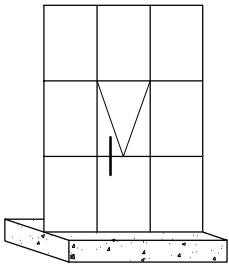









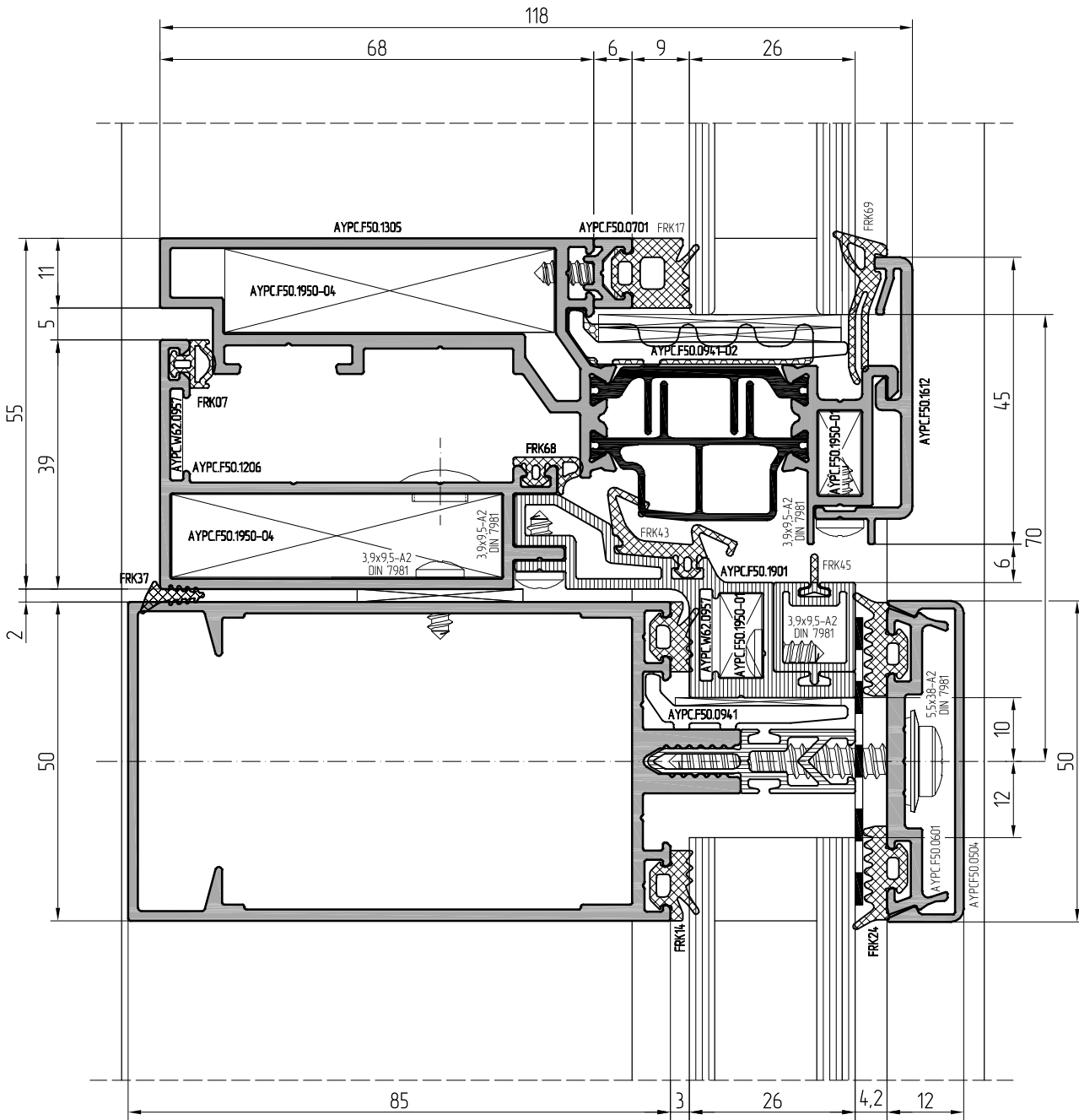
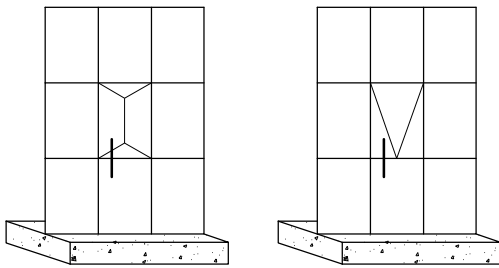

Scale 1:1

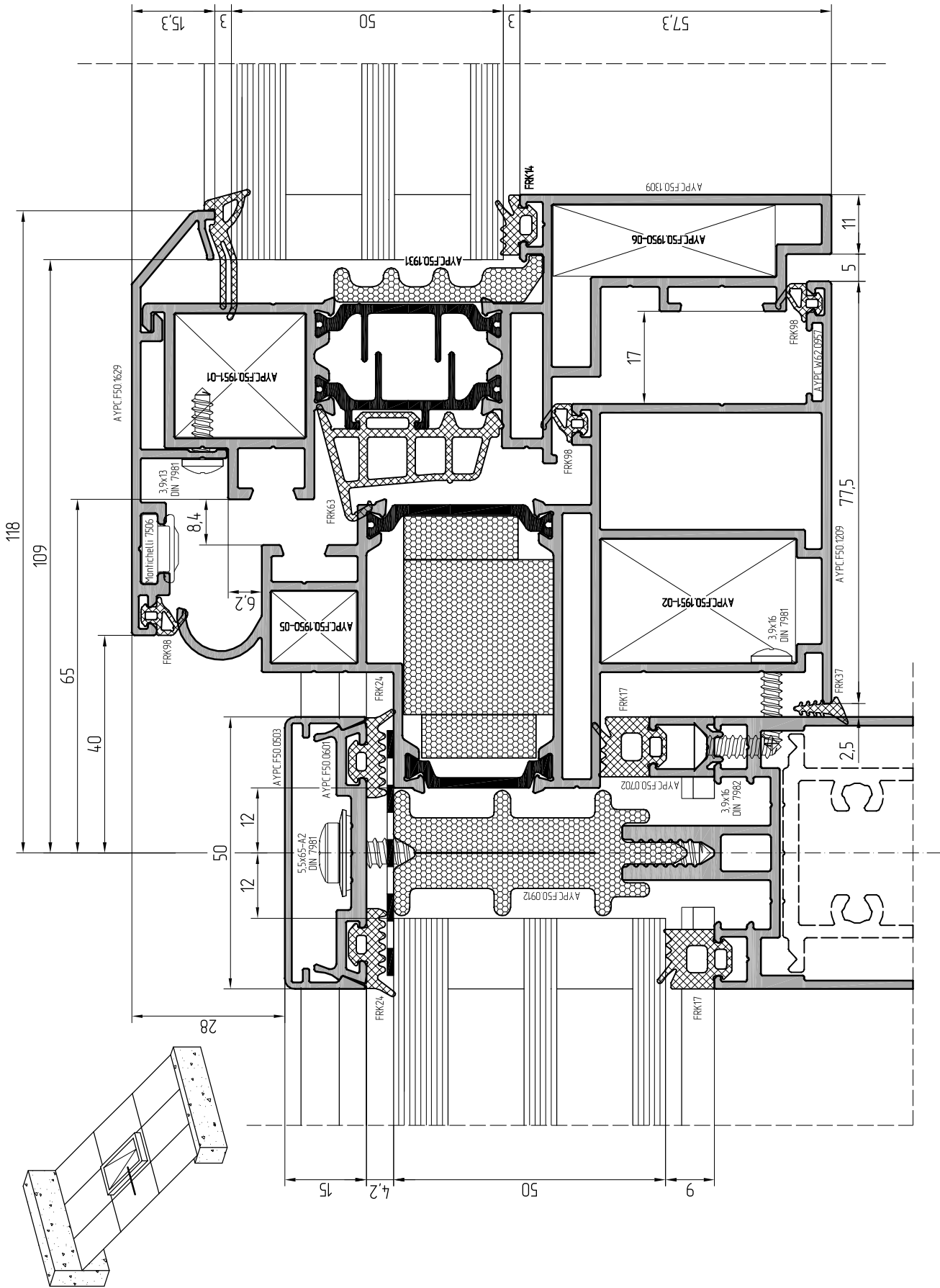

Scale 1:1

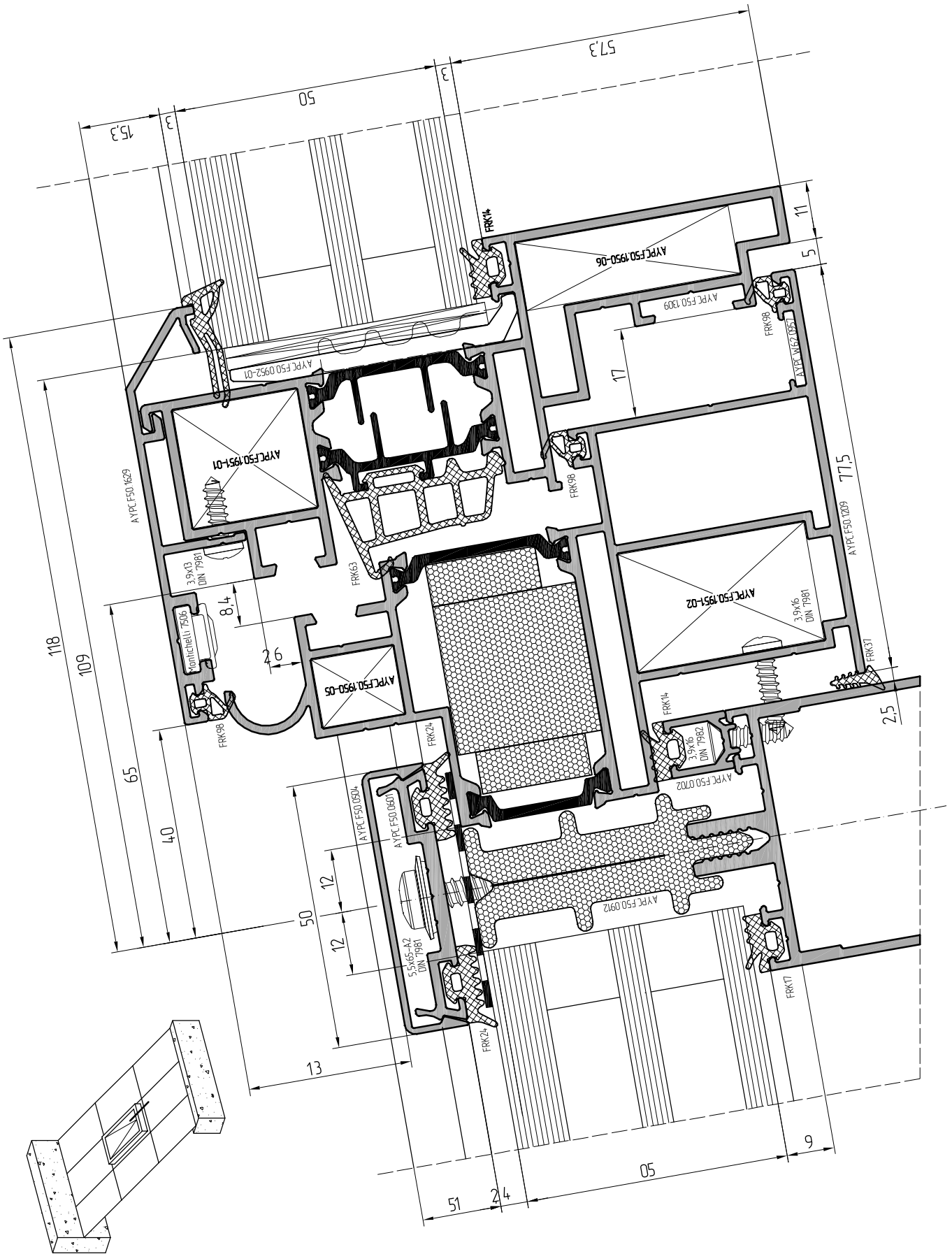

Scale 1:1

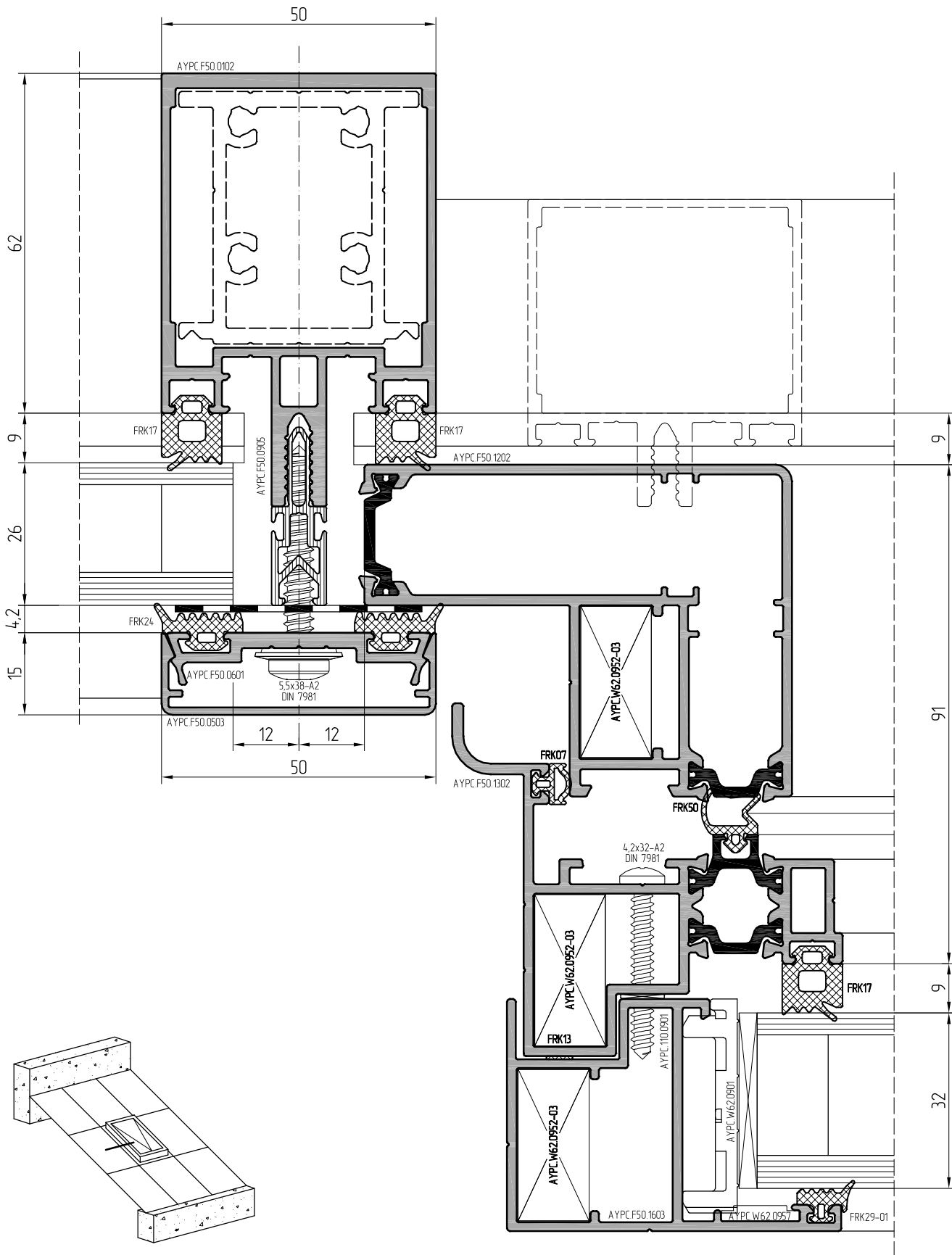



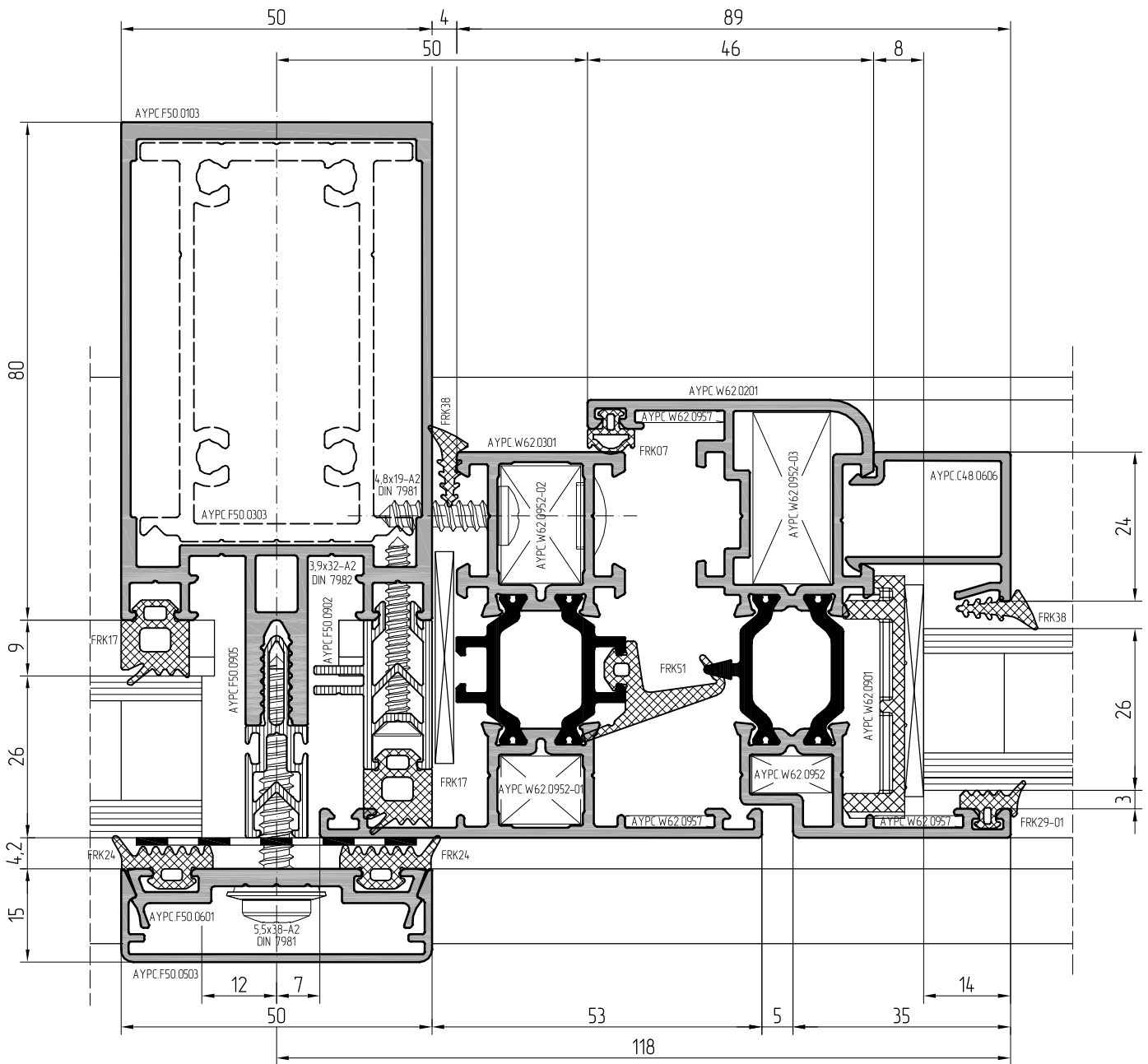
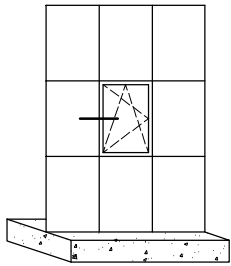

- 01
- 02
- 03
- 04
- 05
- 06
- 07
- 08
- 09
- 10
- 11
- 12
- 13





Scale 1:1

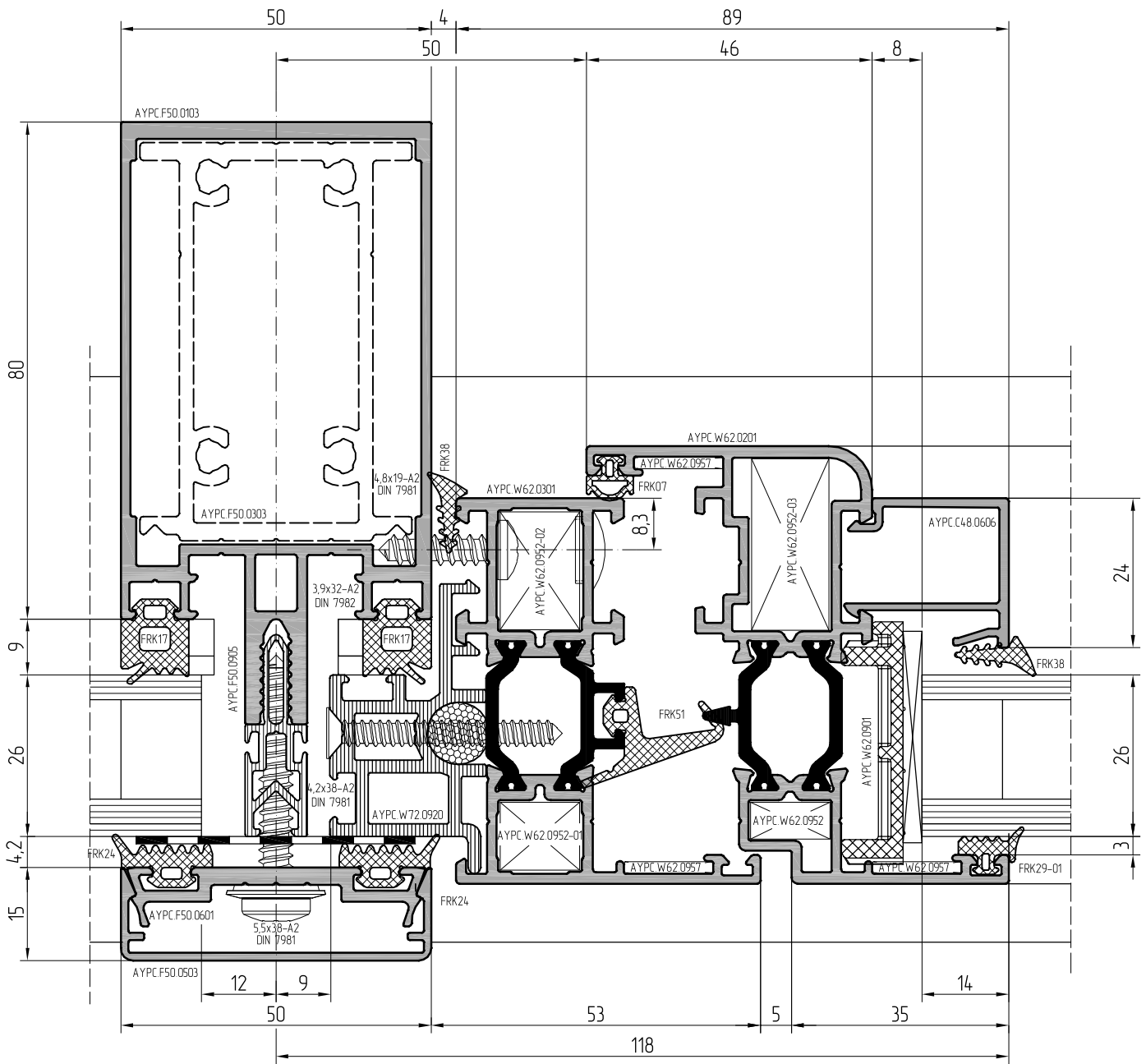
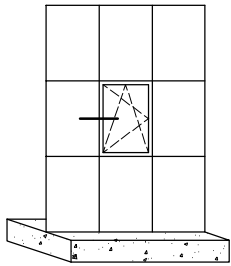









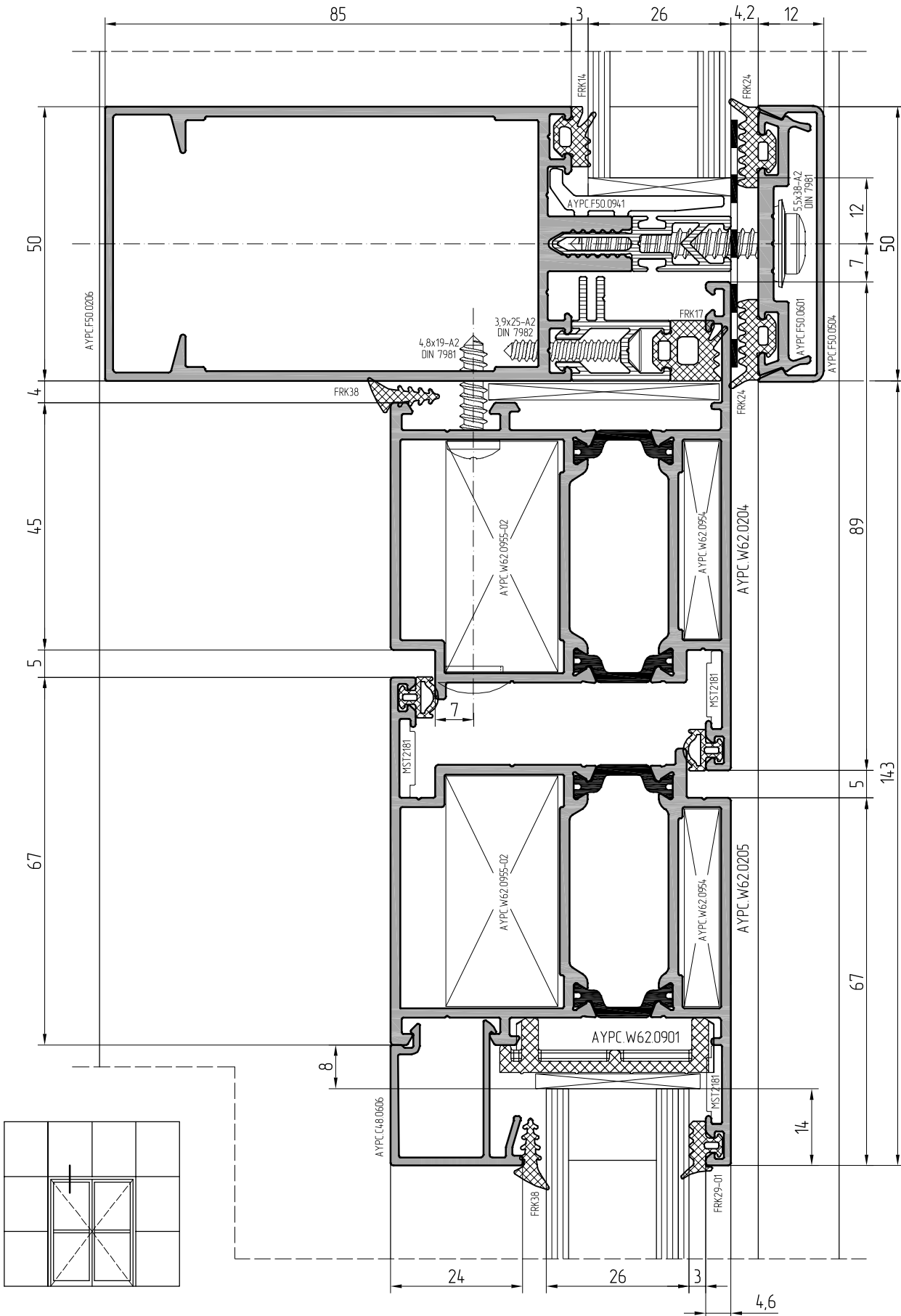

Scale 1:1

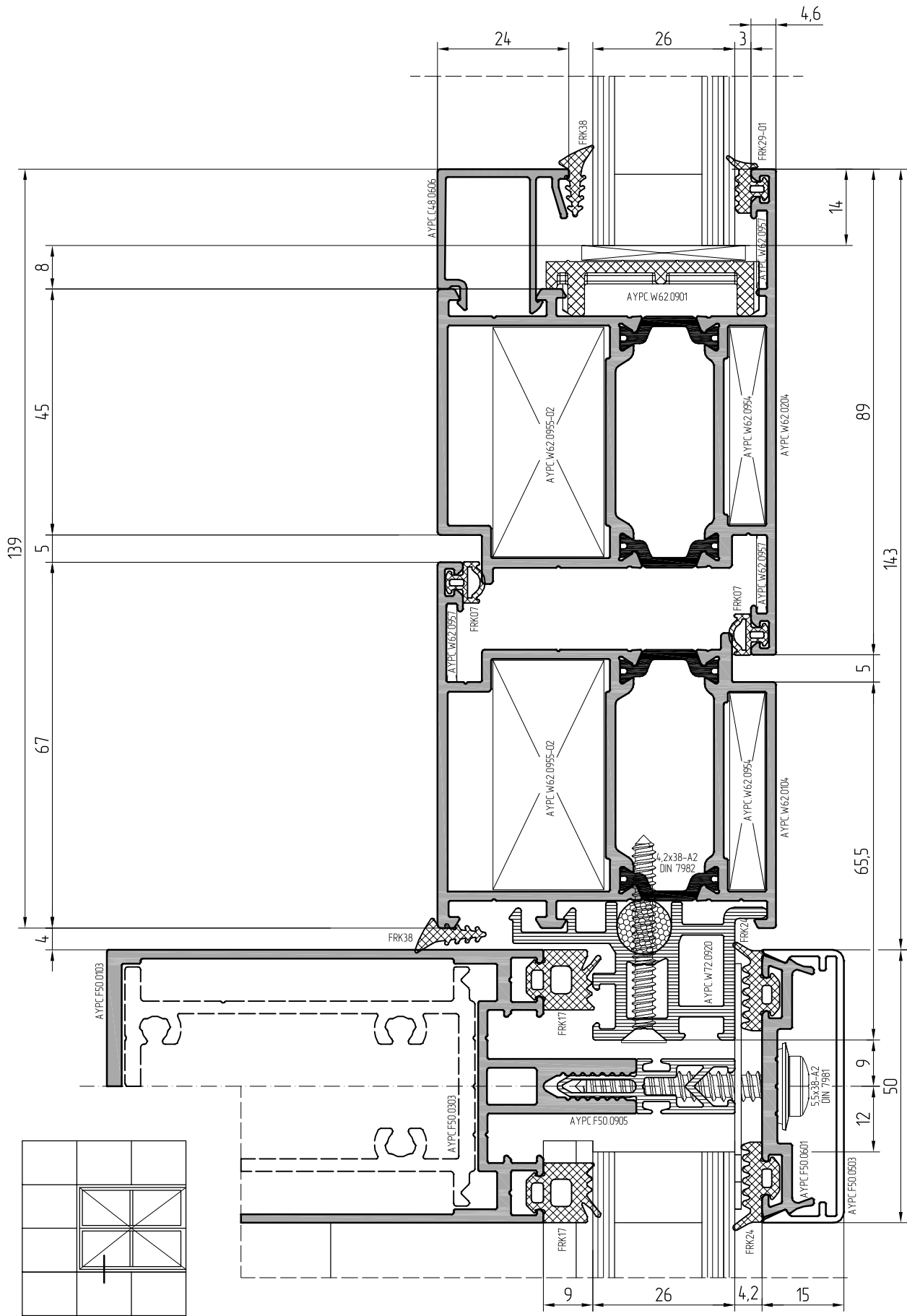

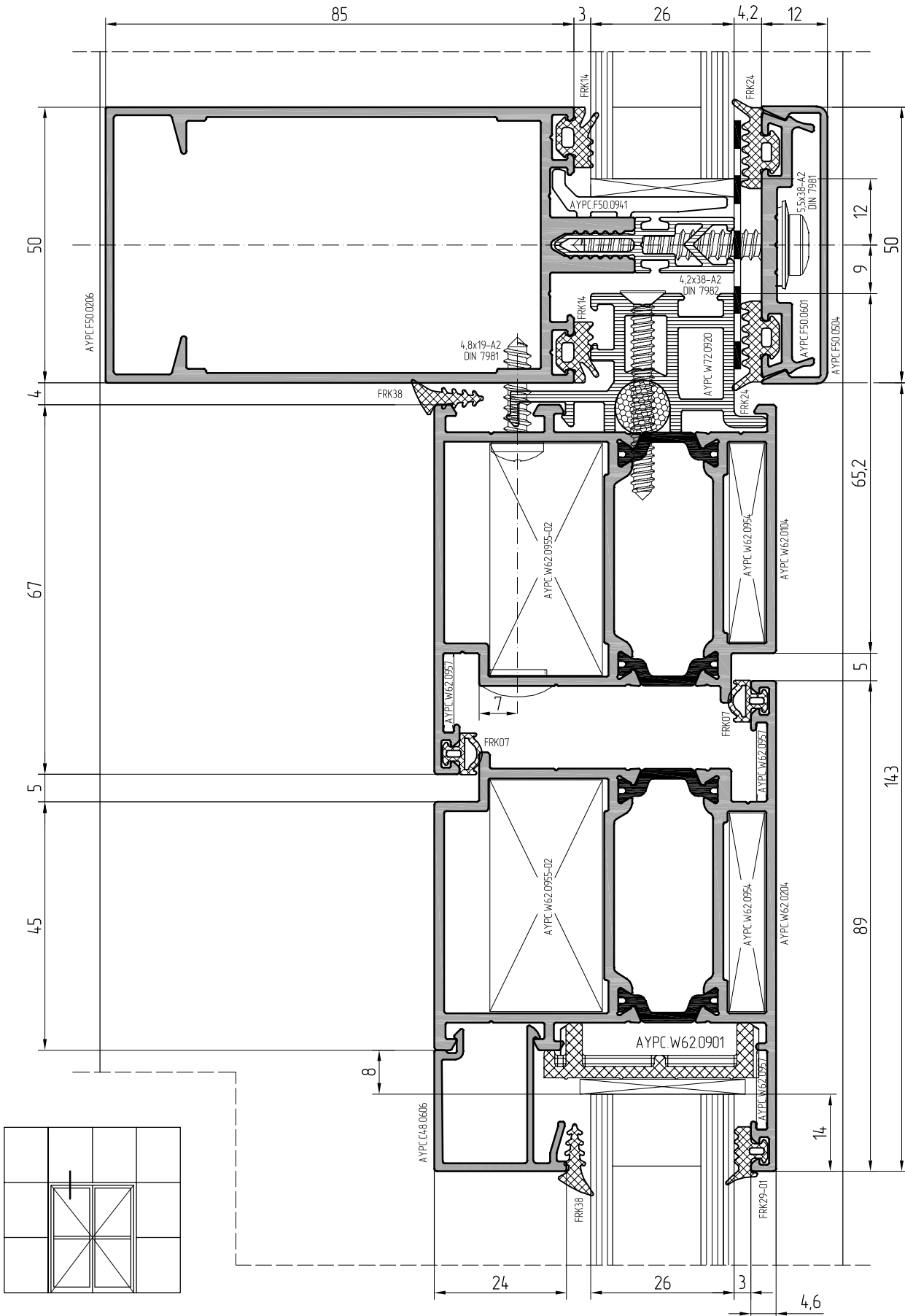



Scale 1:1

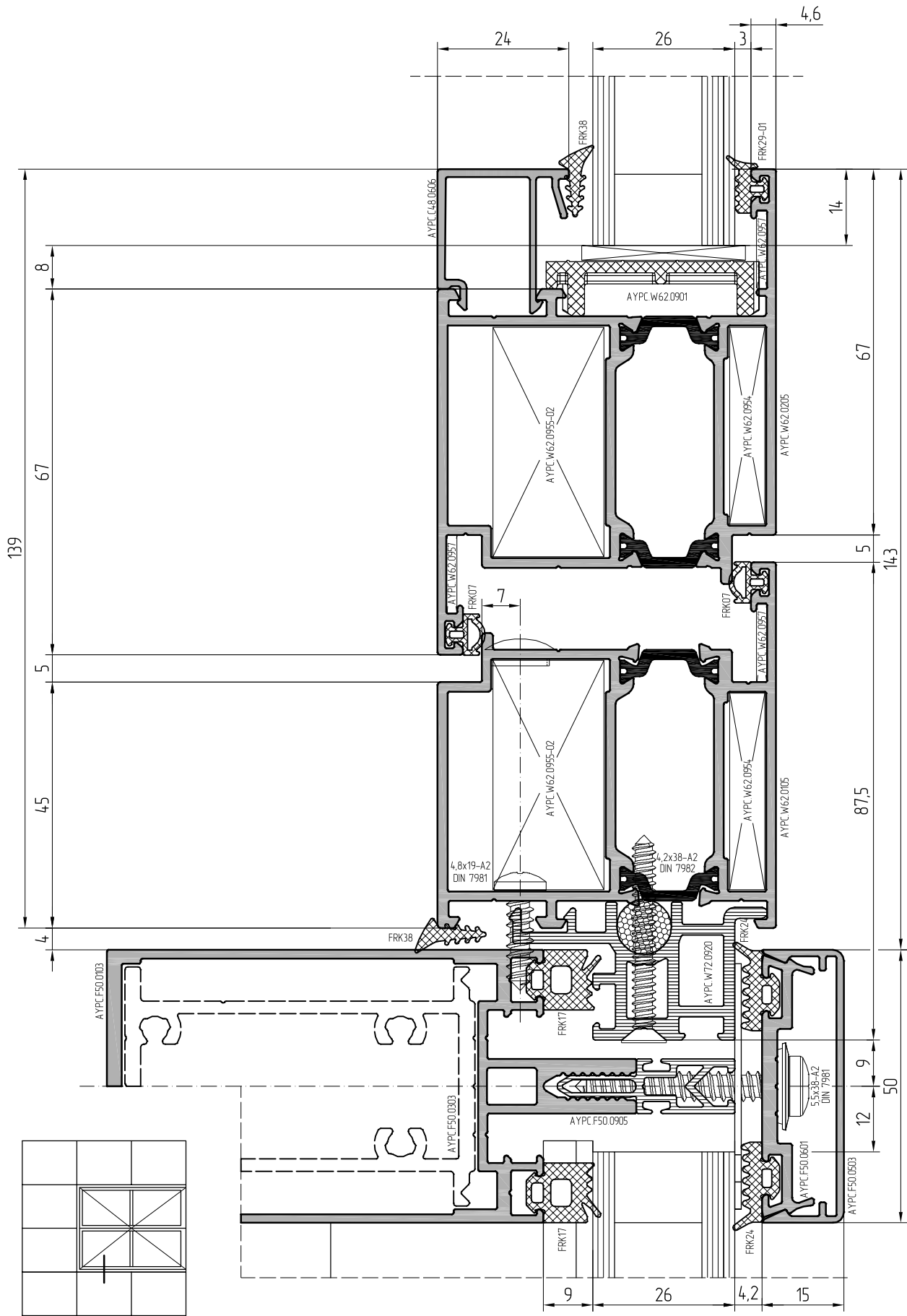

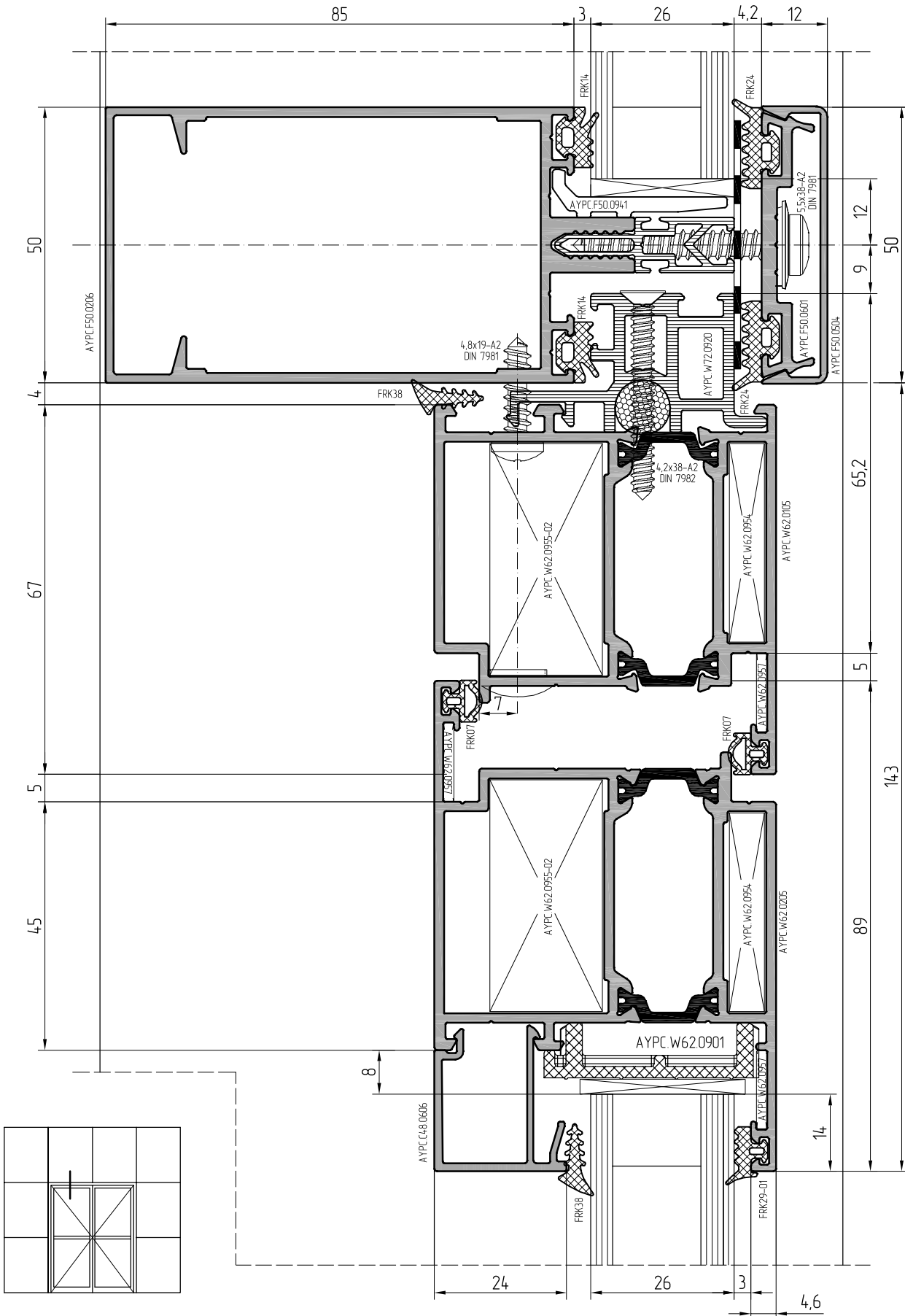



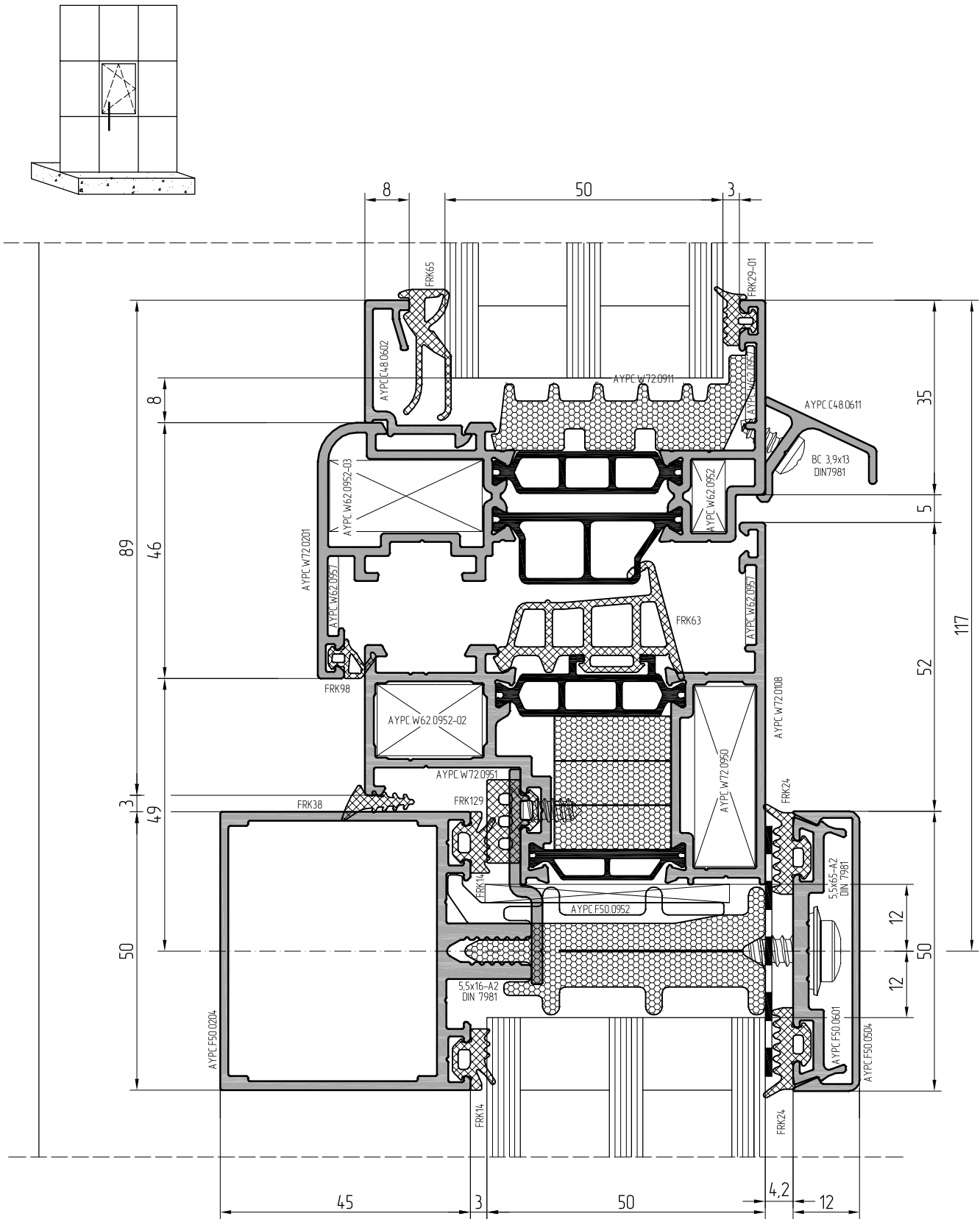

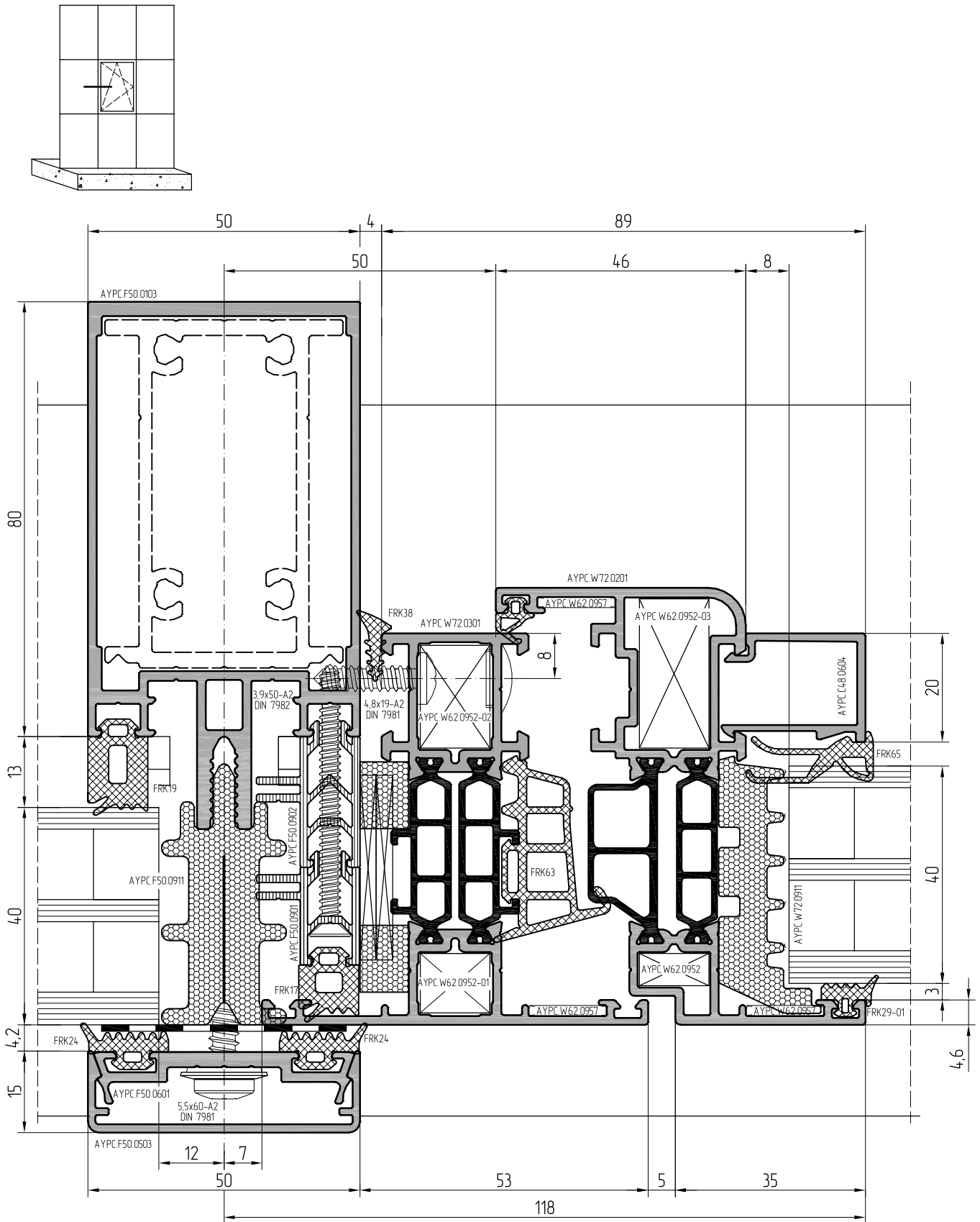



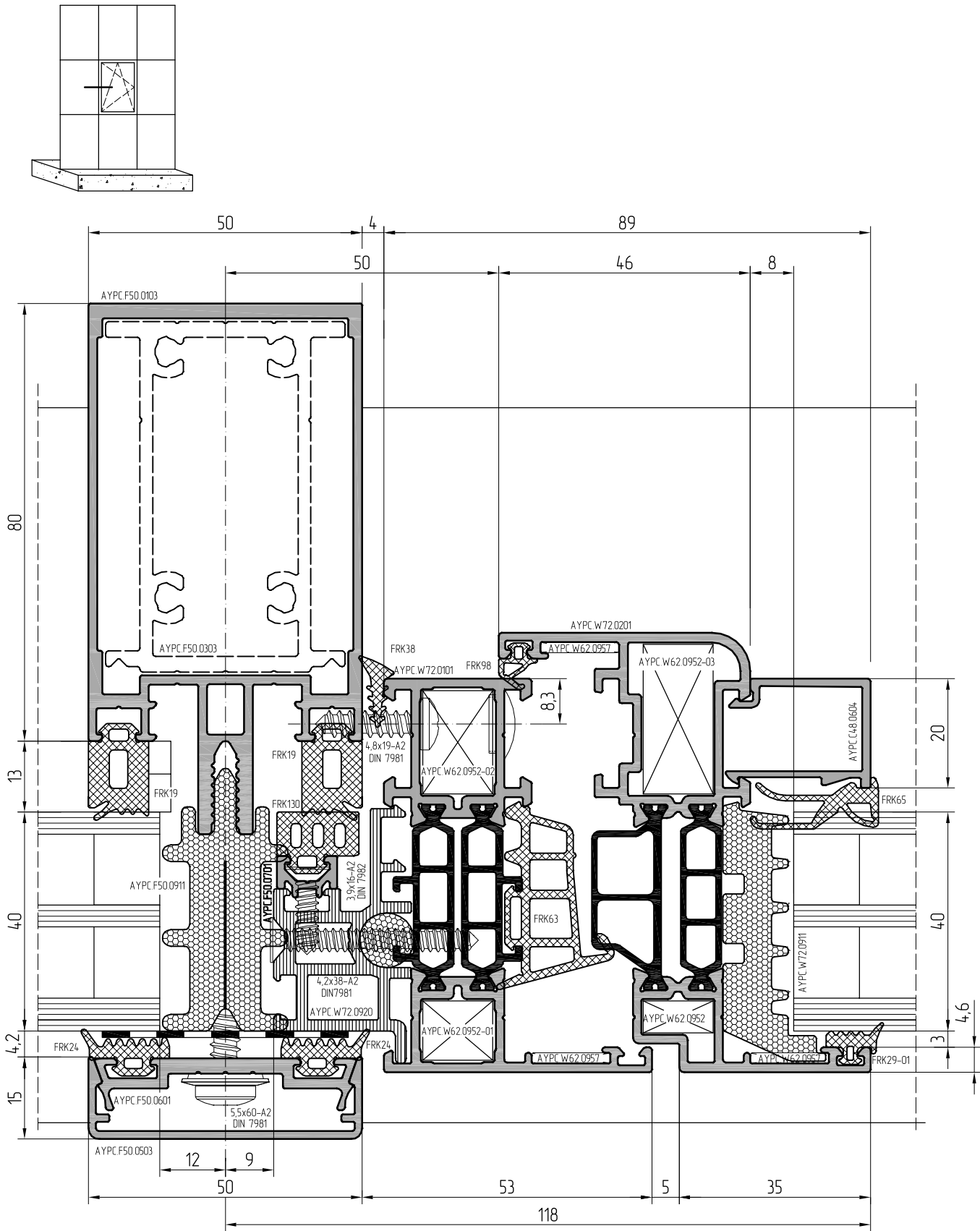

- 01
- 02
- 03
- 04
- 05
- 06
- 07
- 08
- 09
- 10
- 11
- 12
- 13

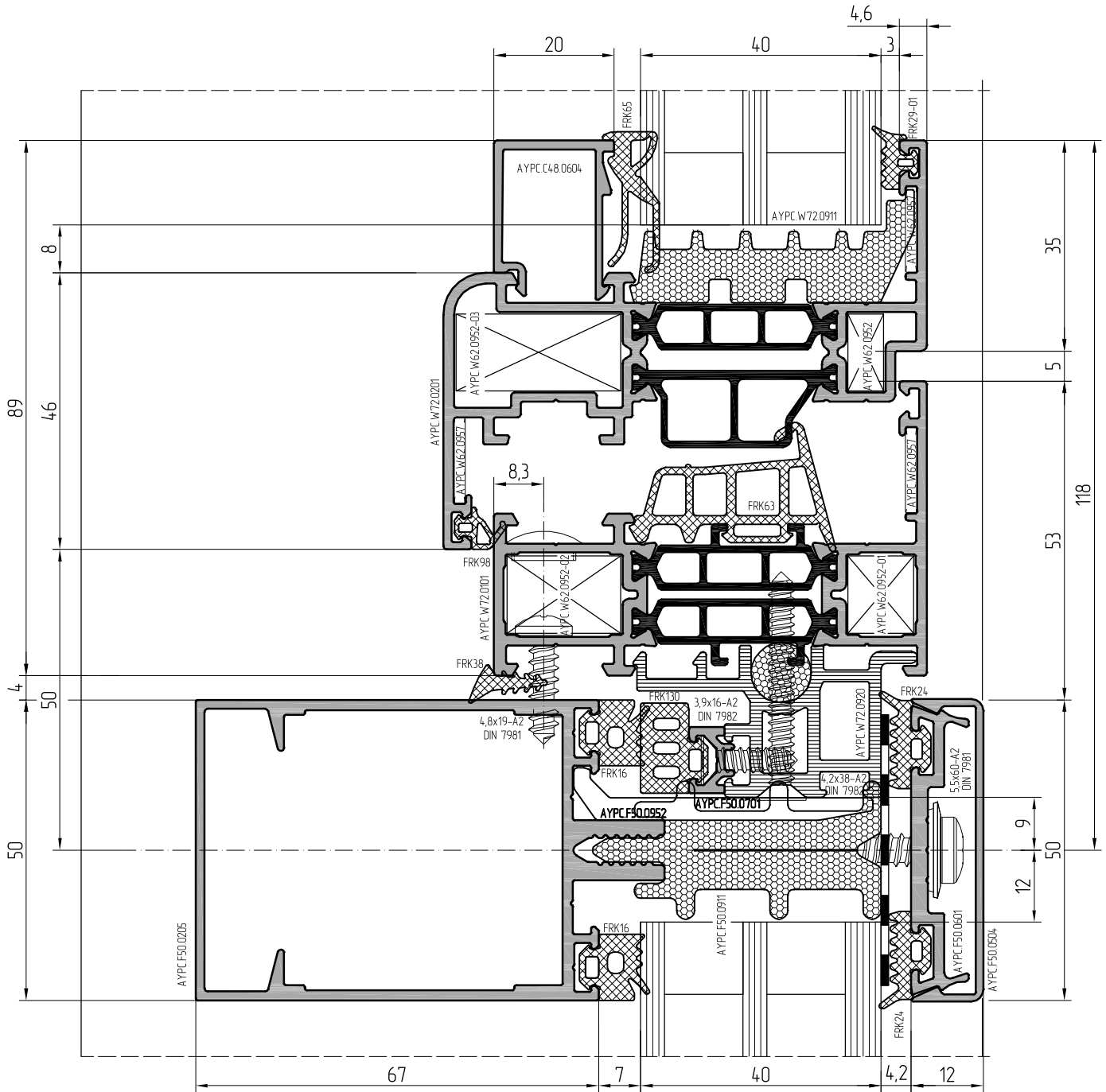
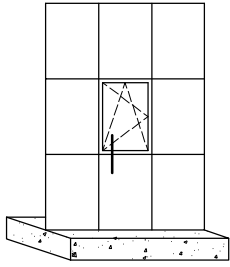



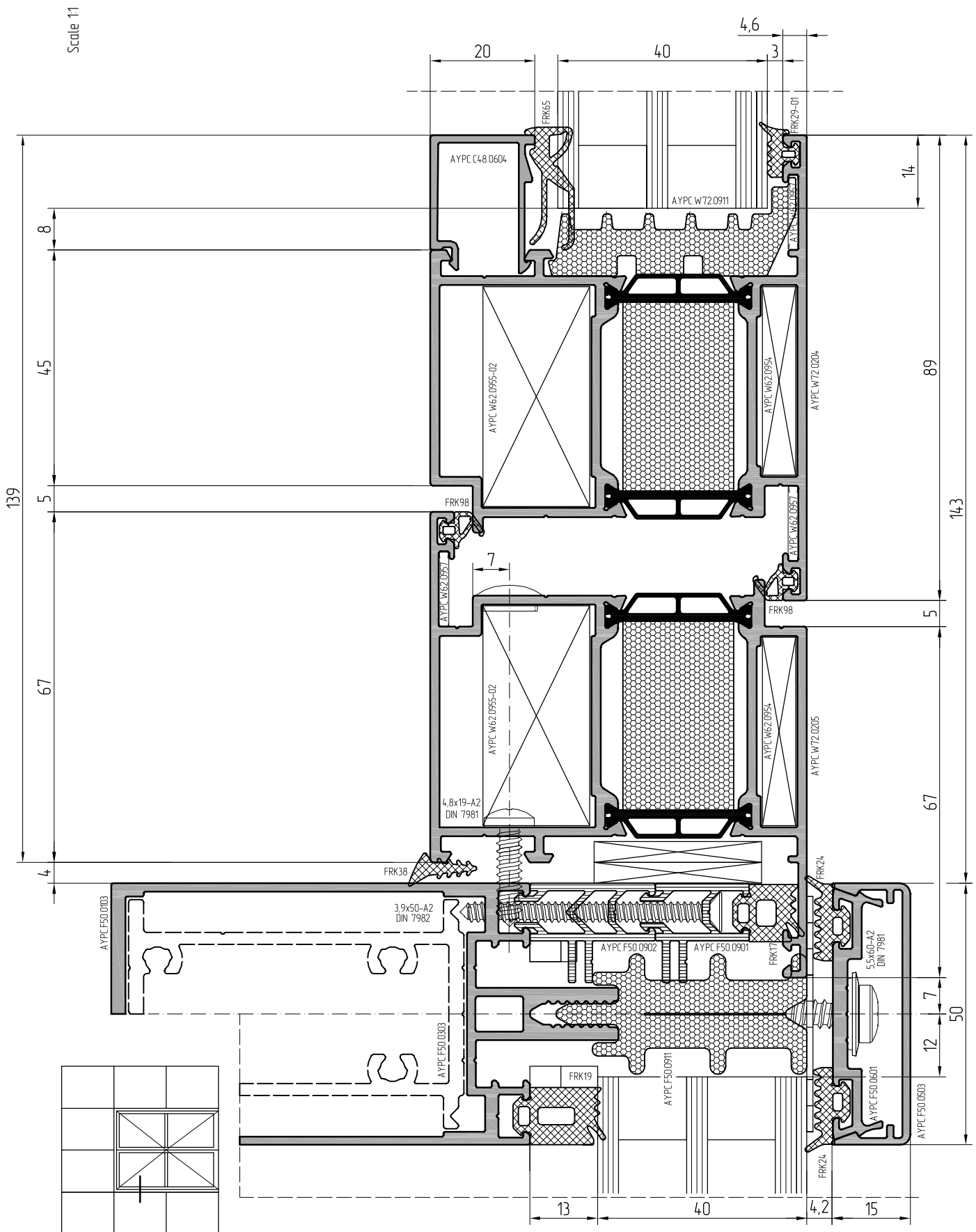

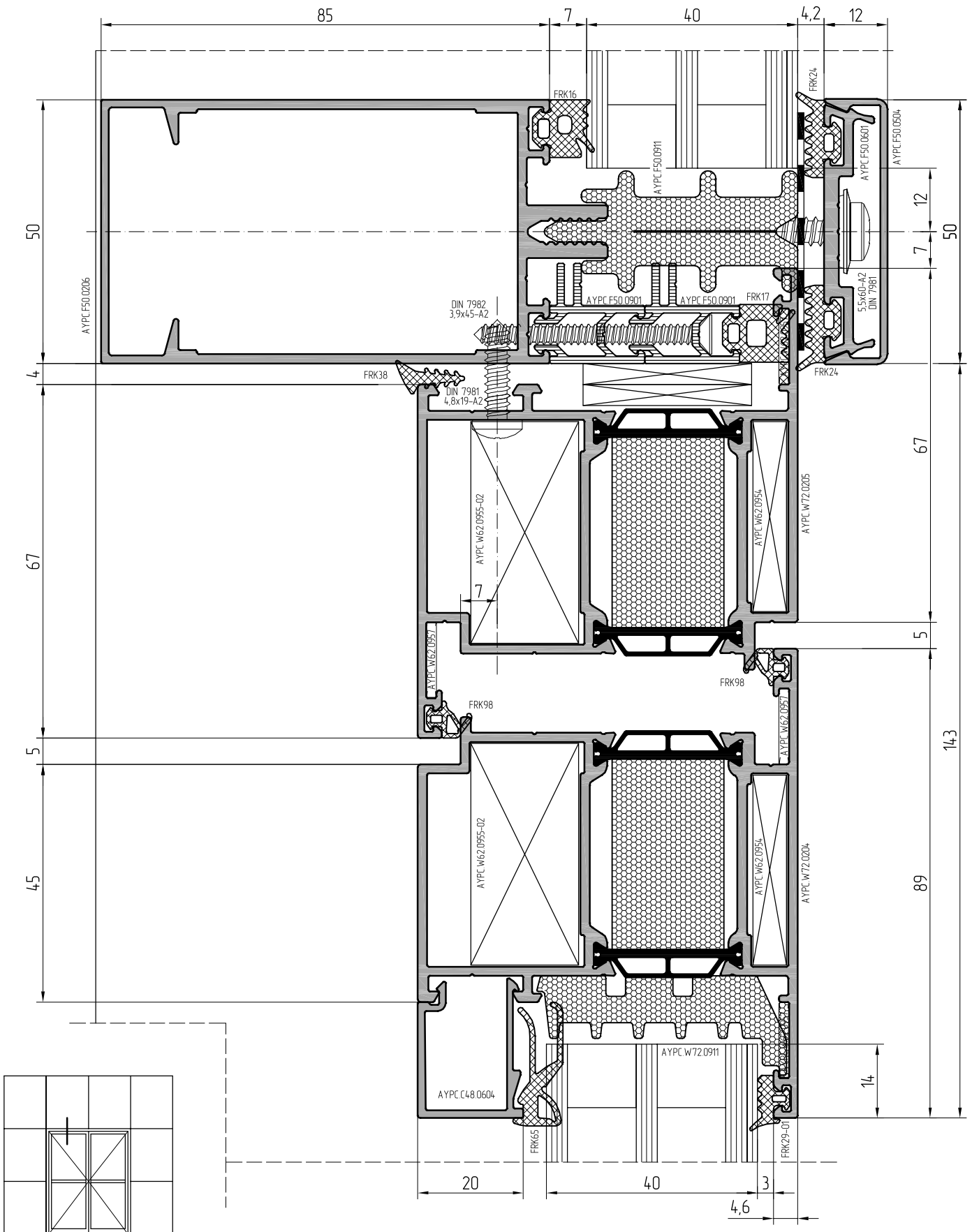



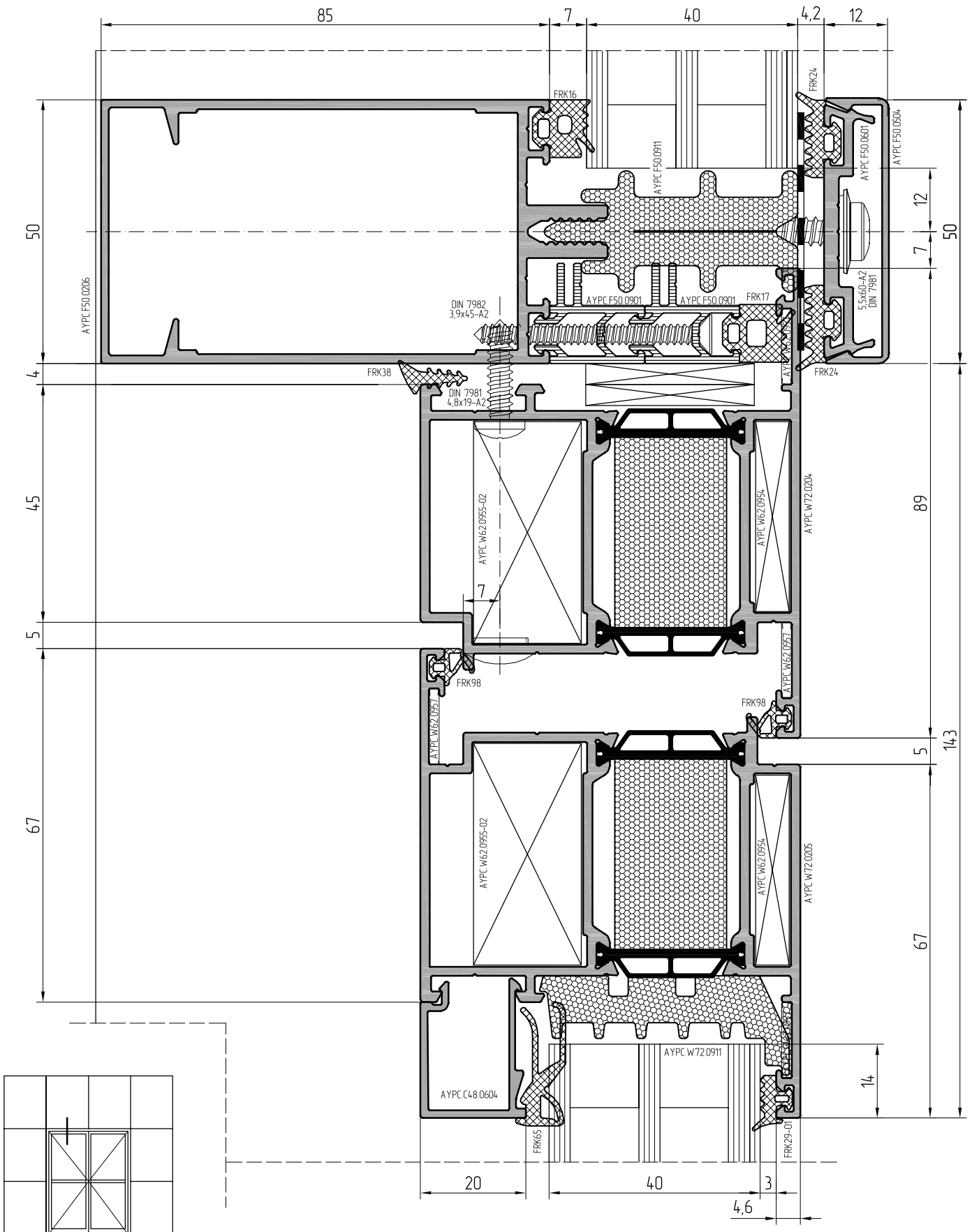

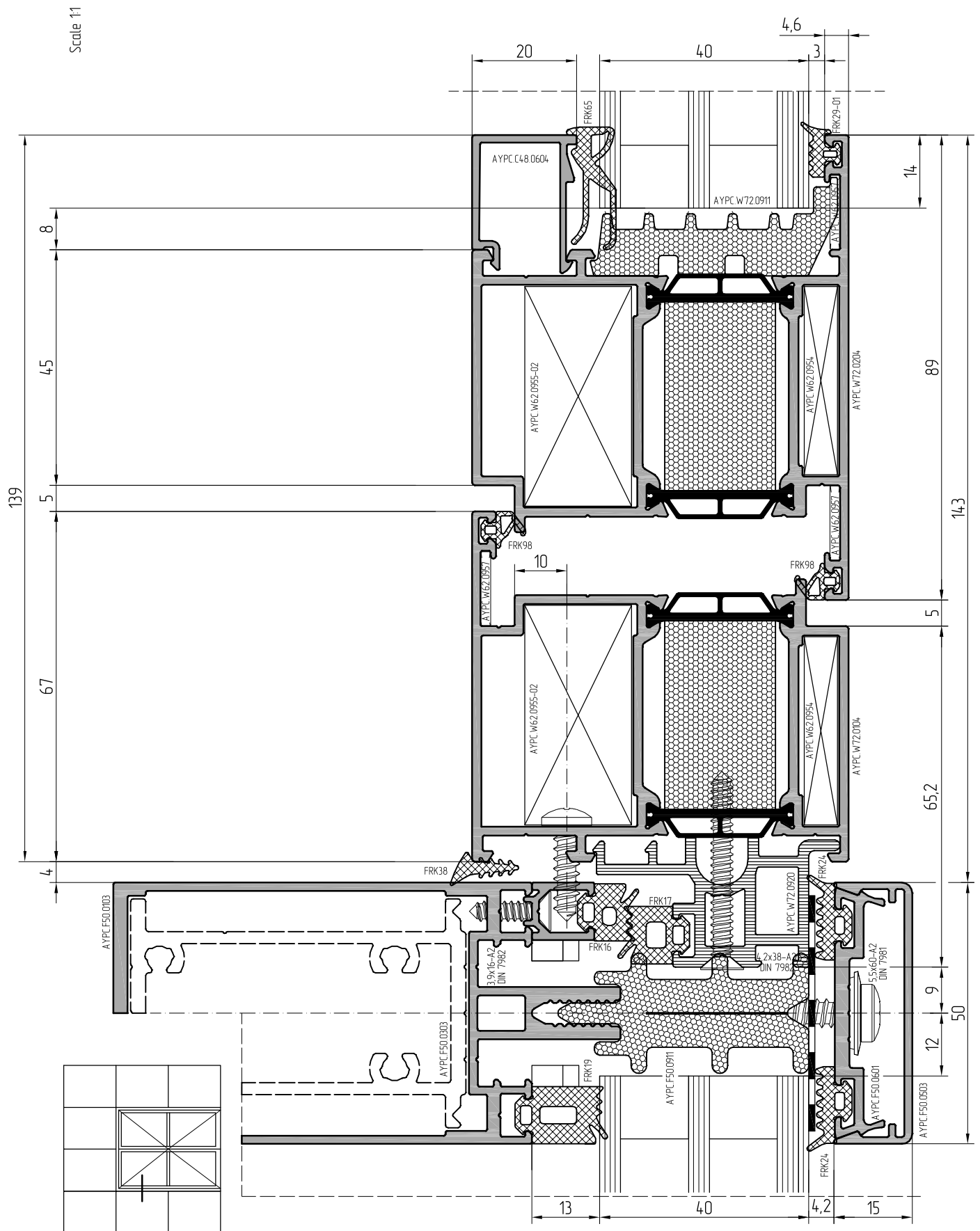



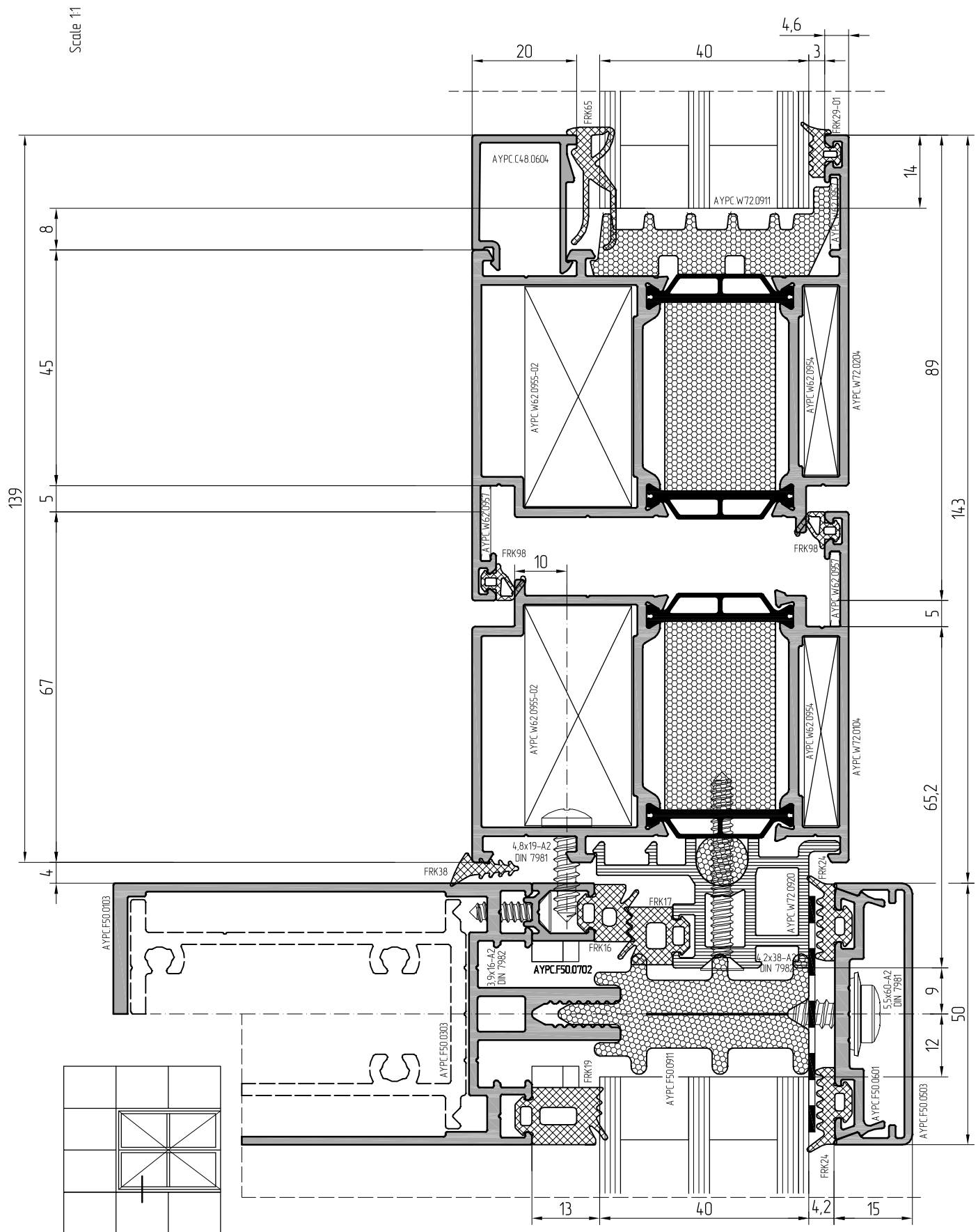



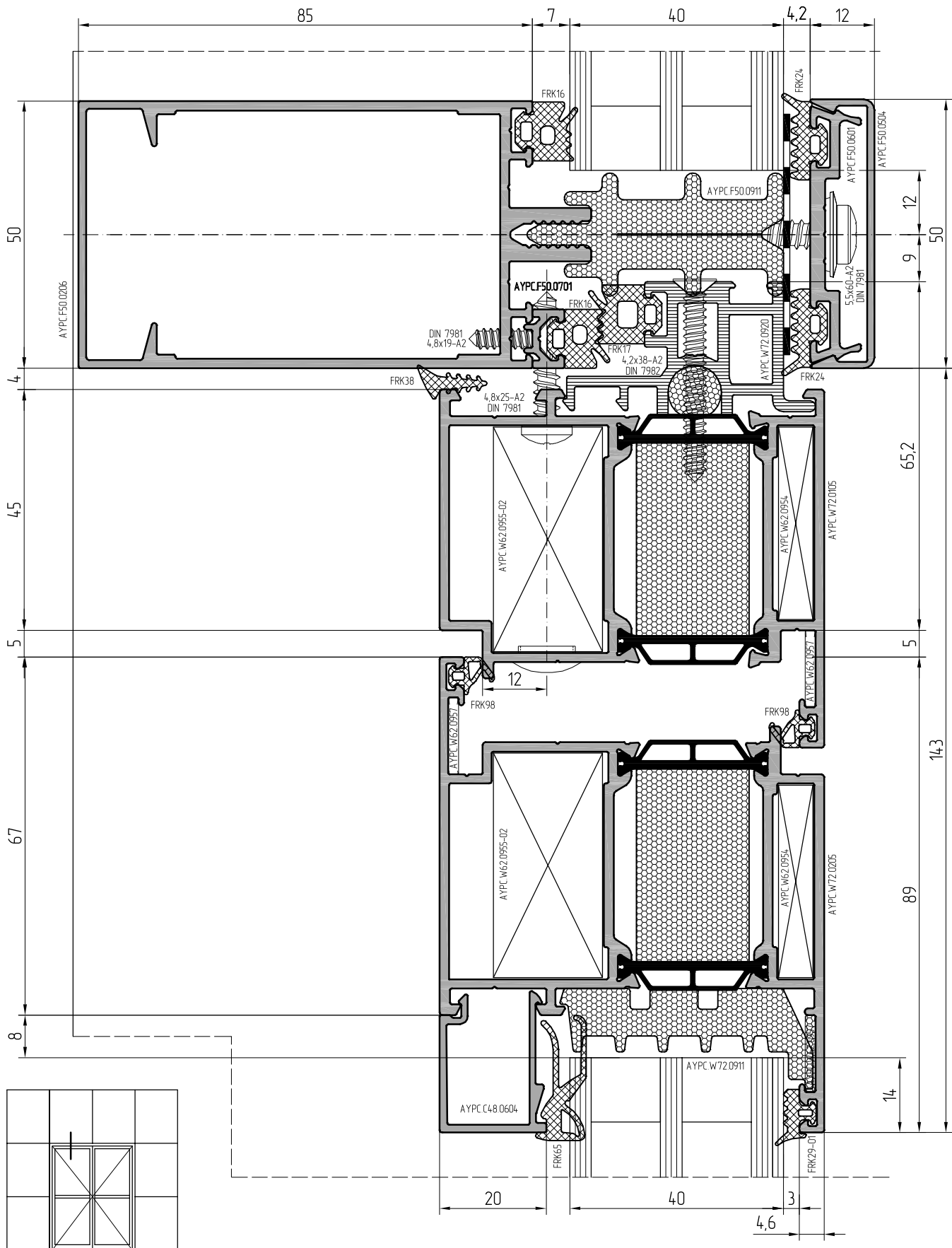



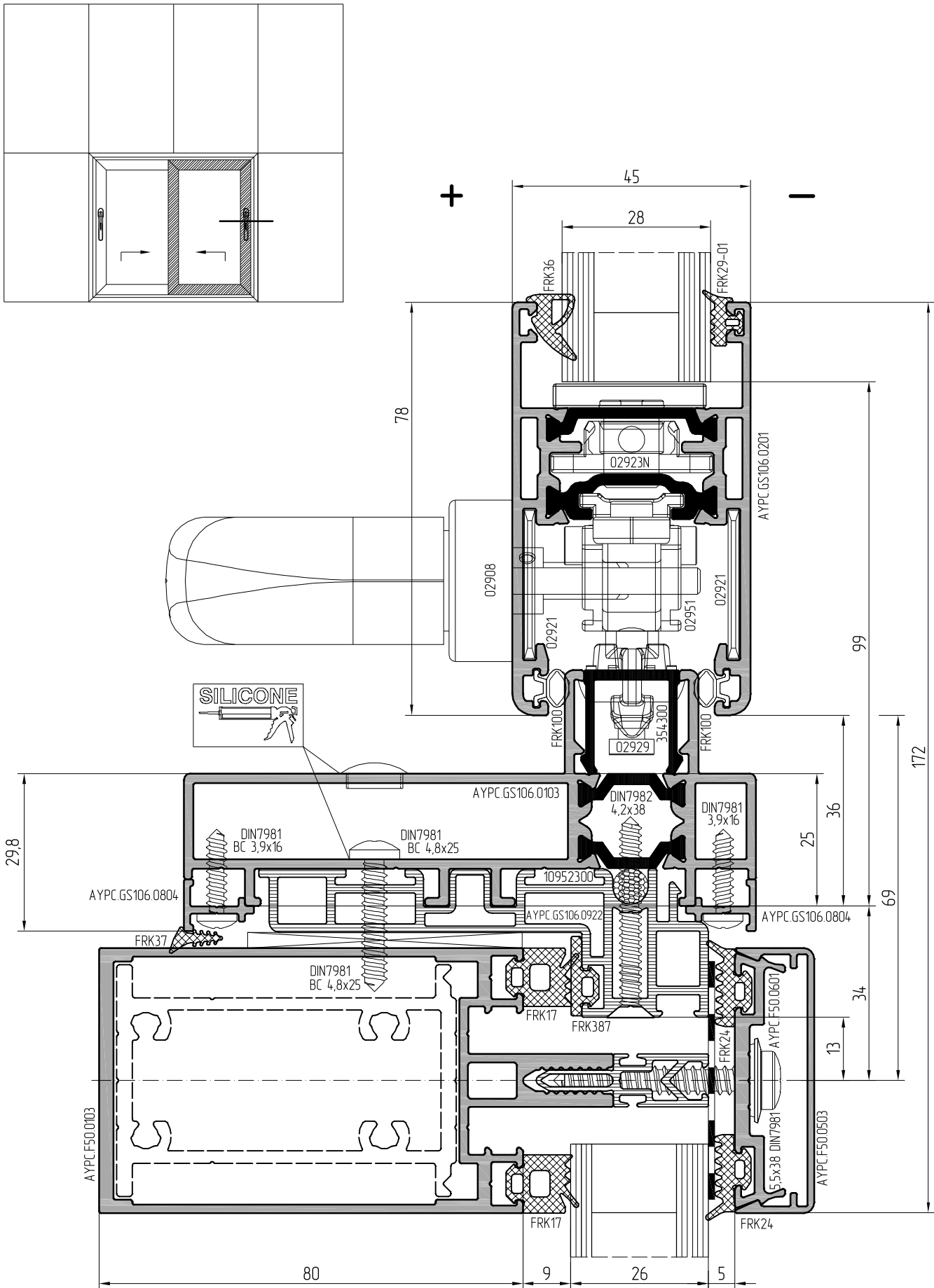

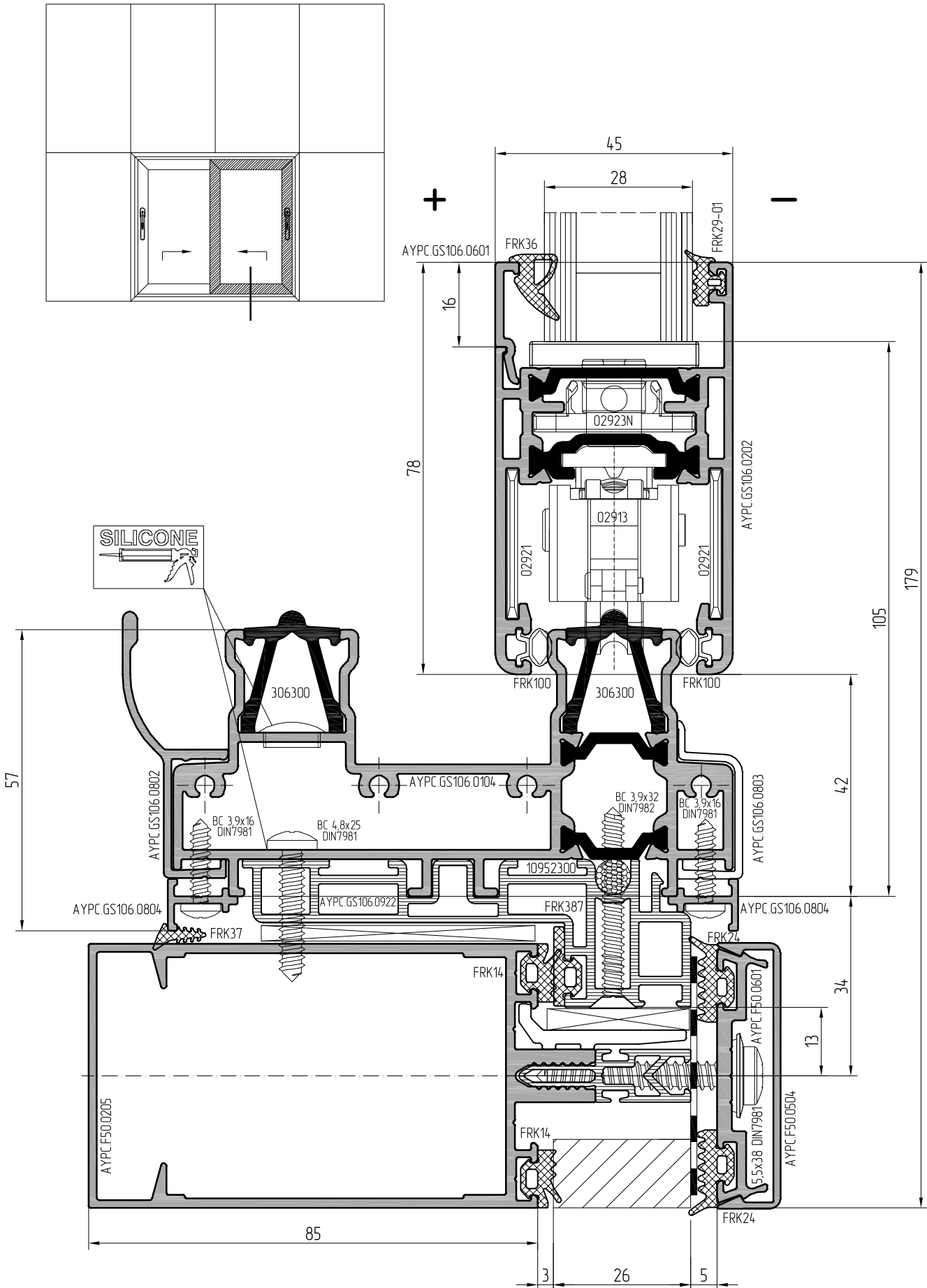

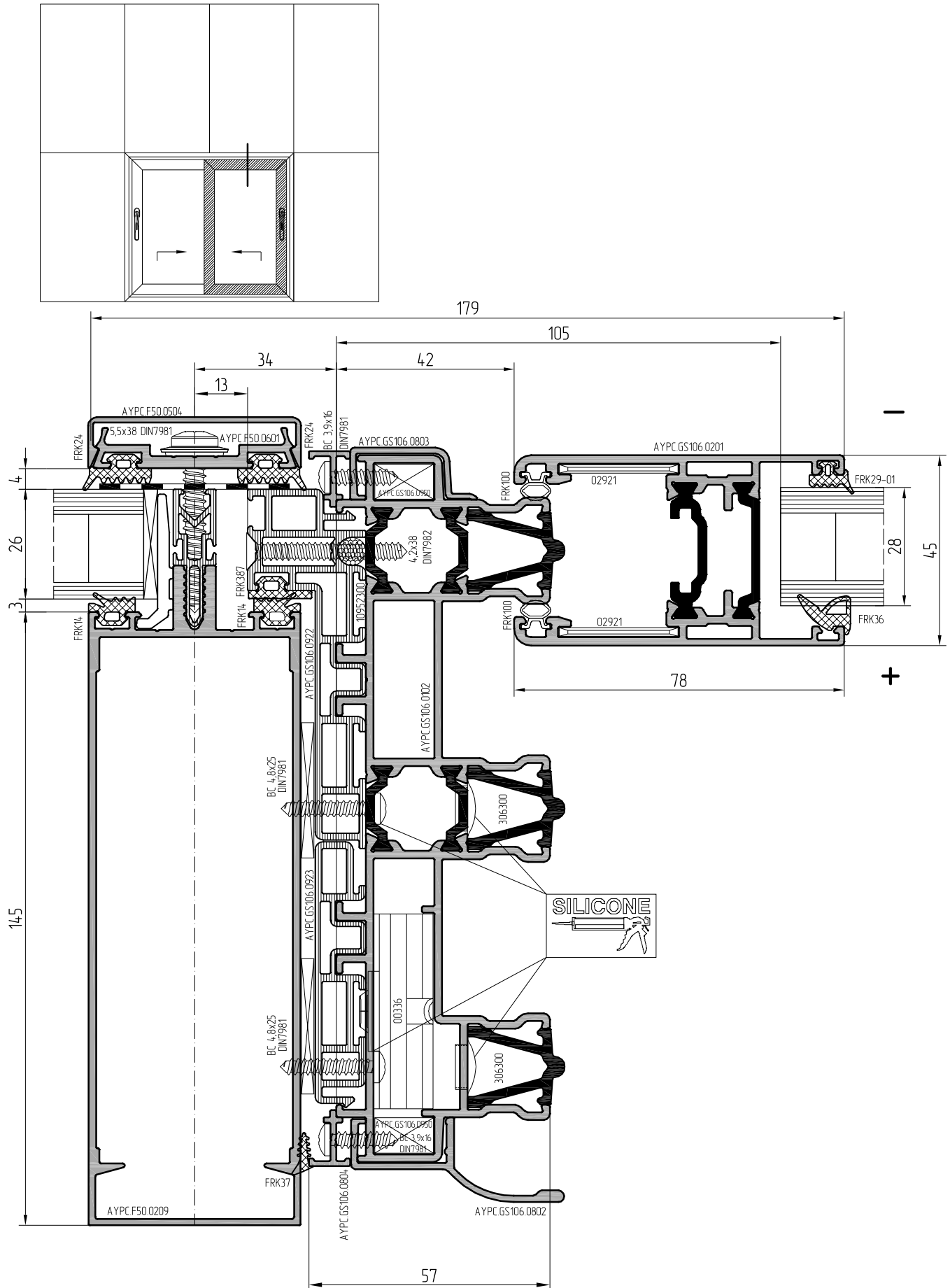





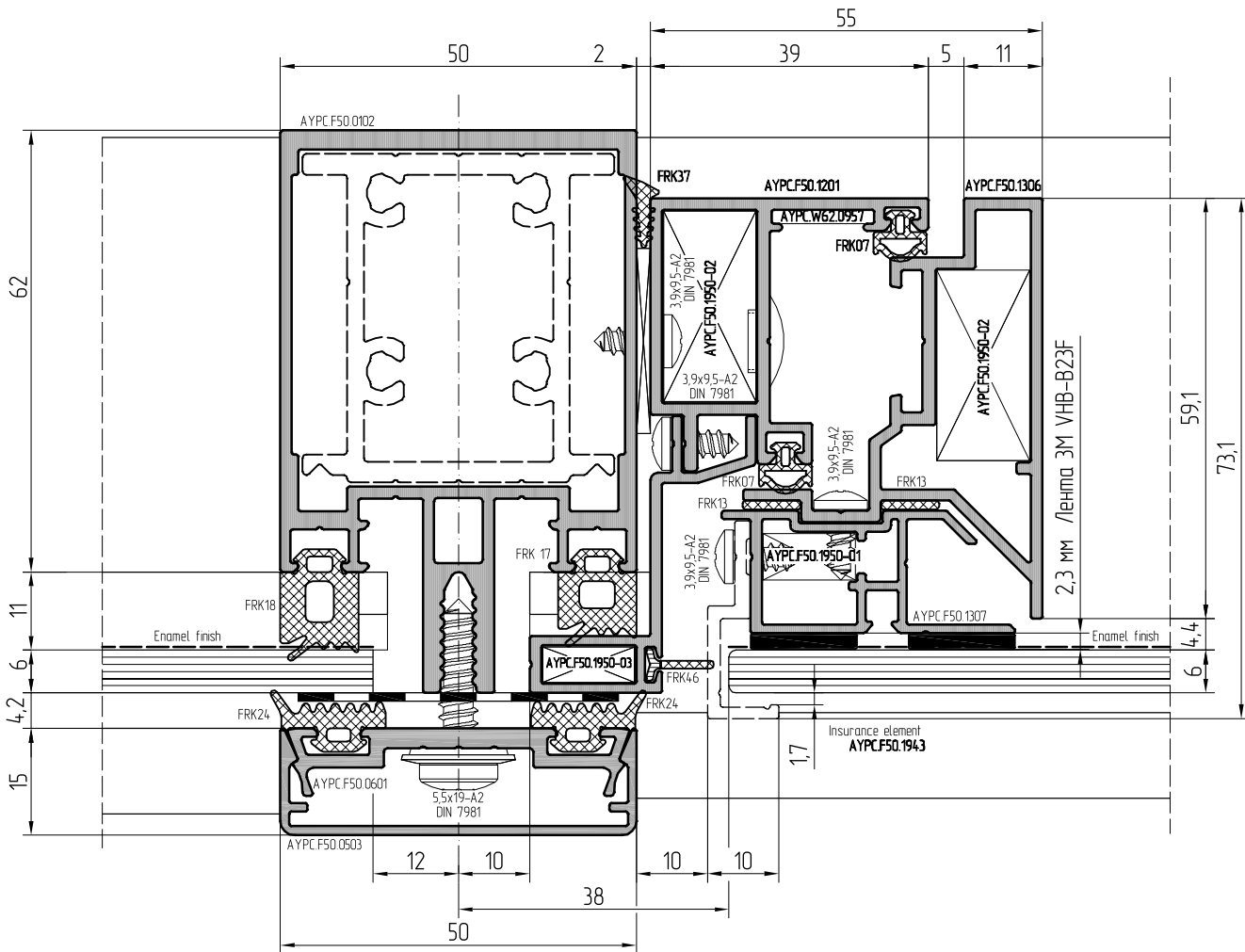
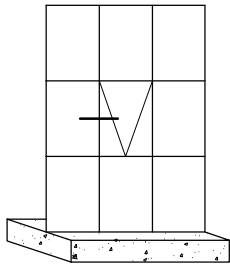

Scale 1:1

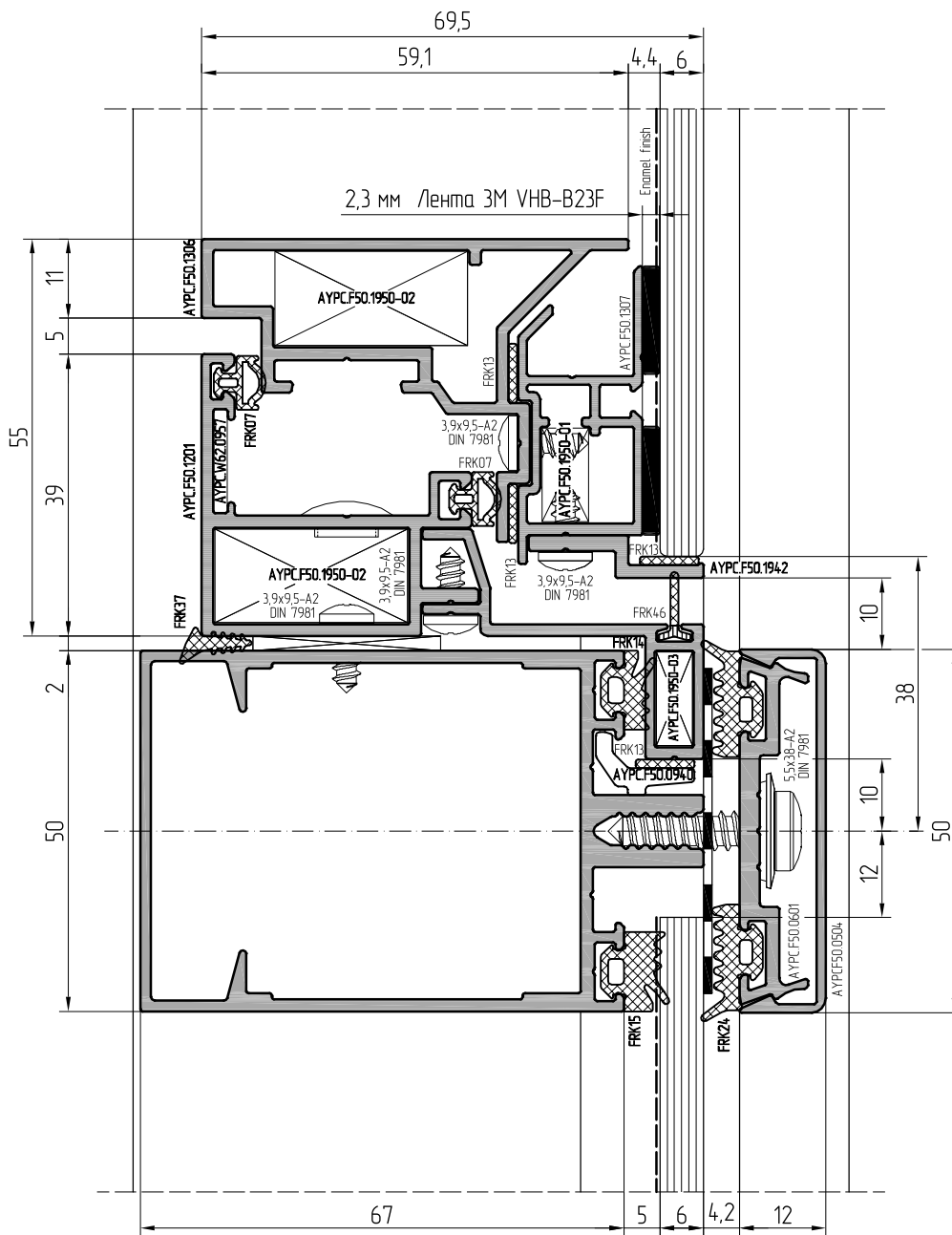
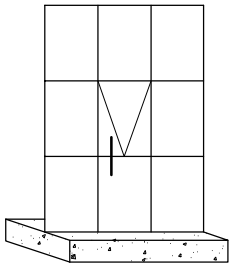

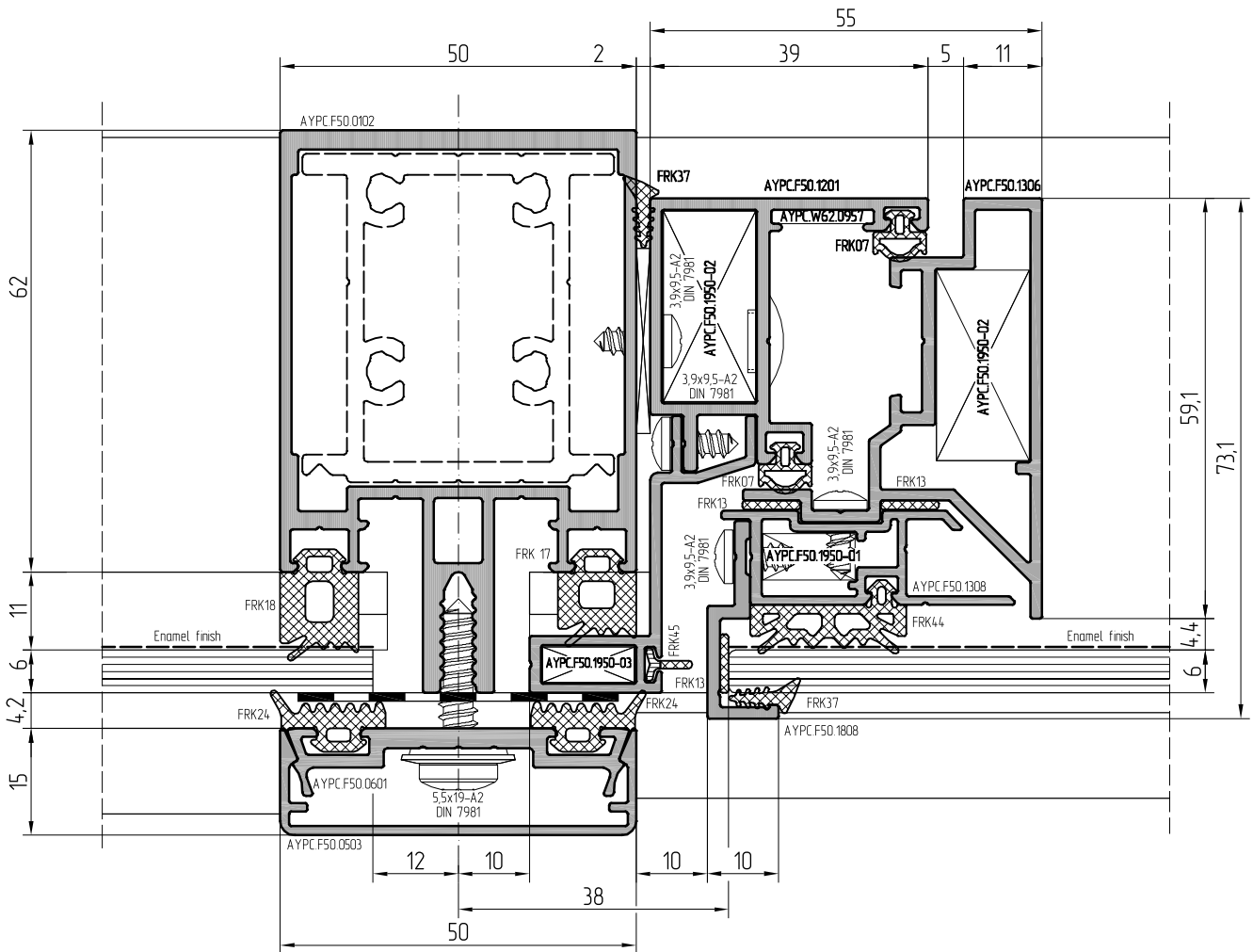
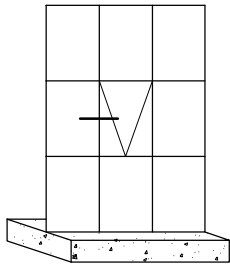



Scale 1:1

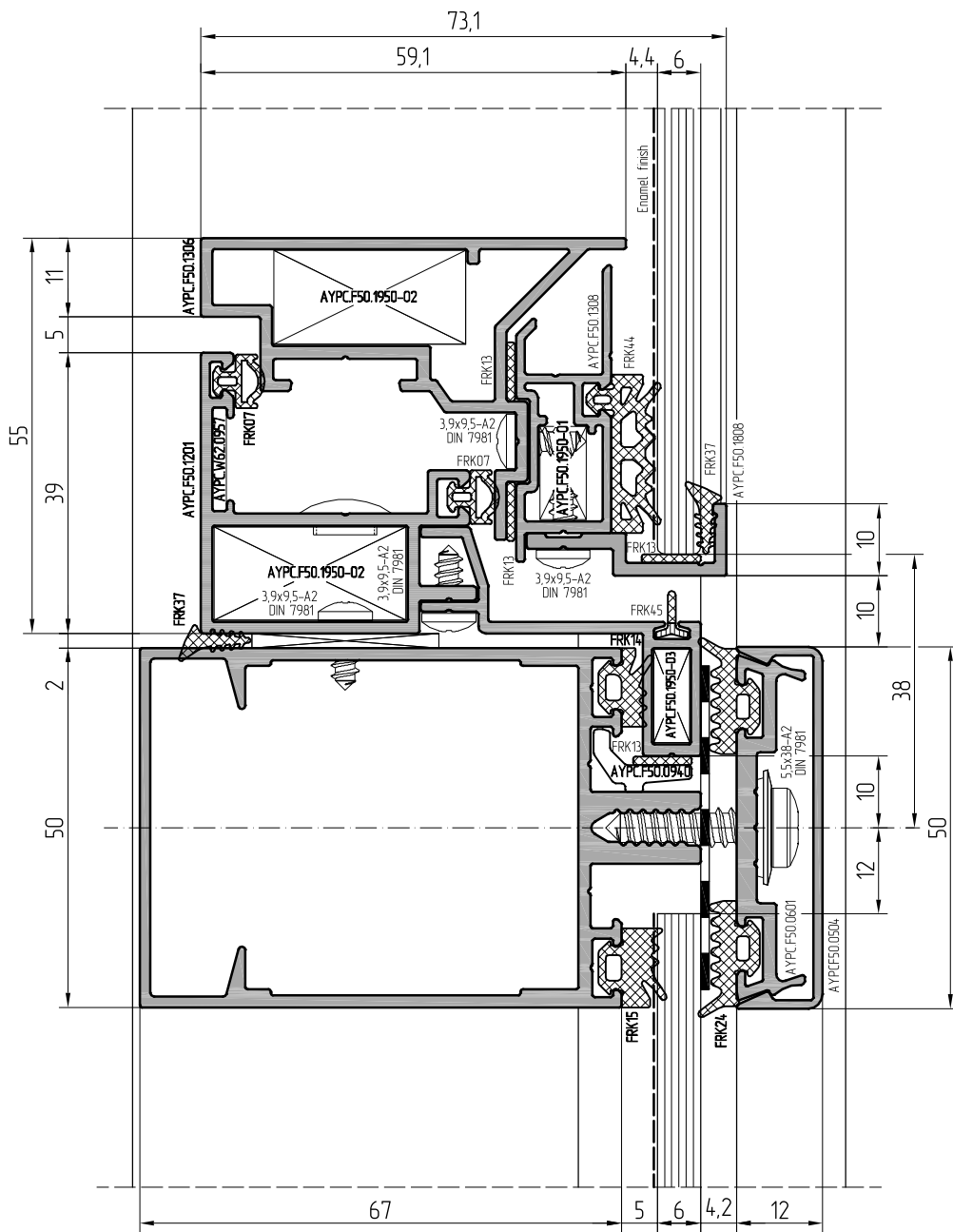
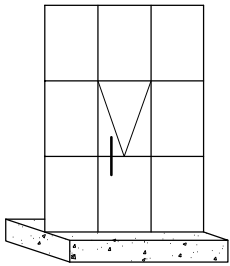

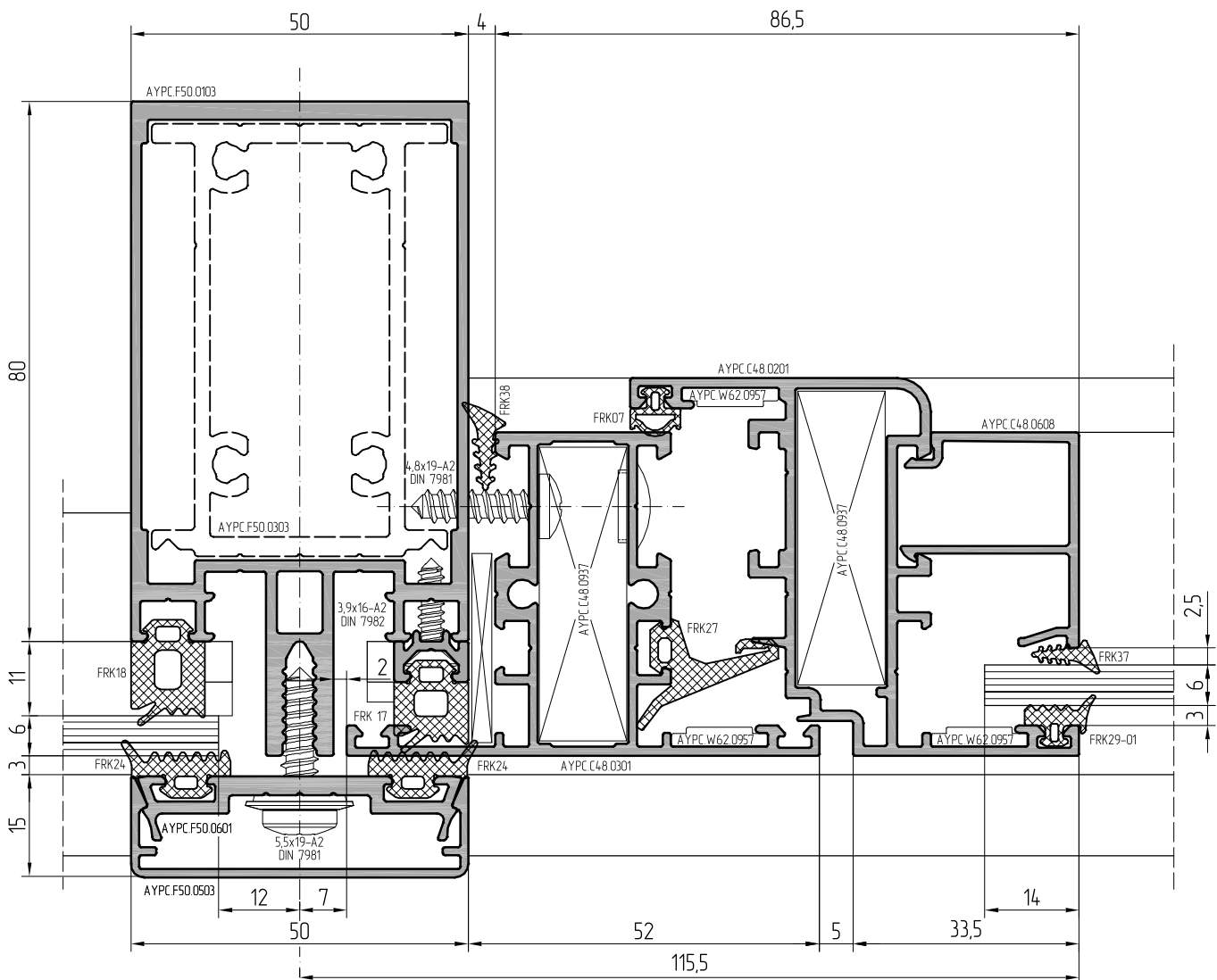
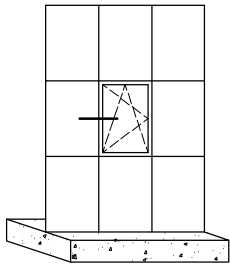

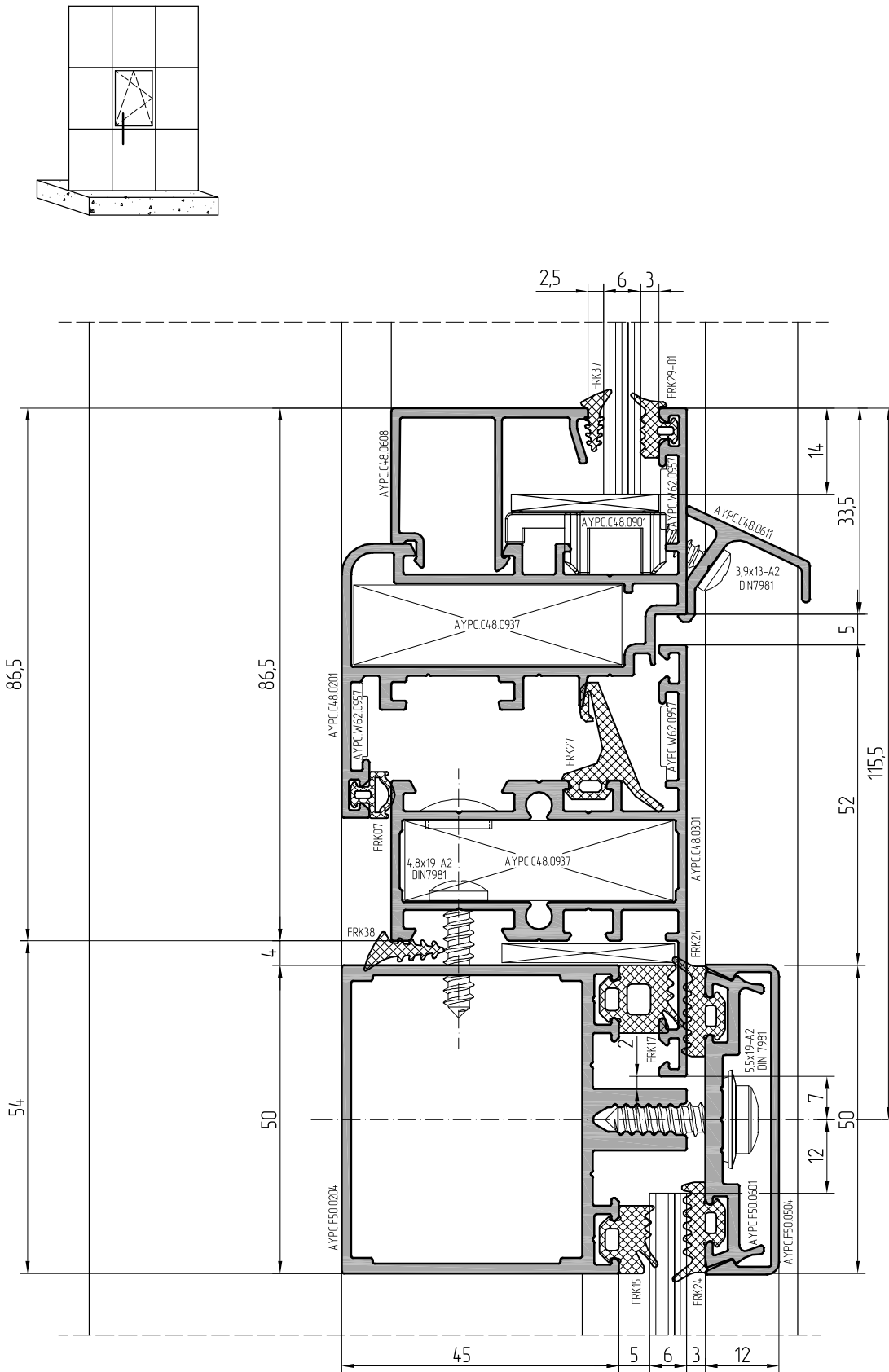

Scale 1:1

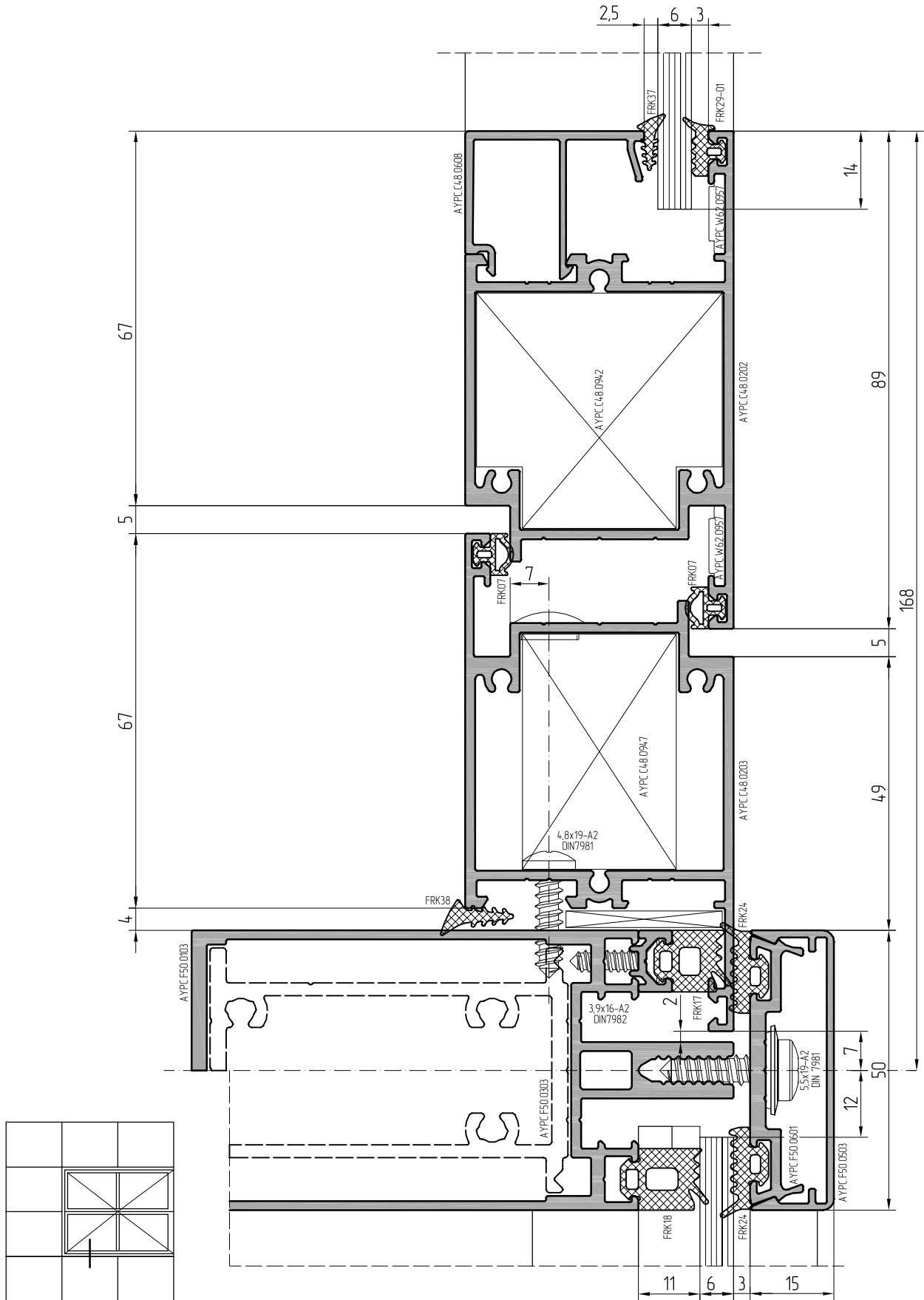





Scale 1:1

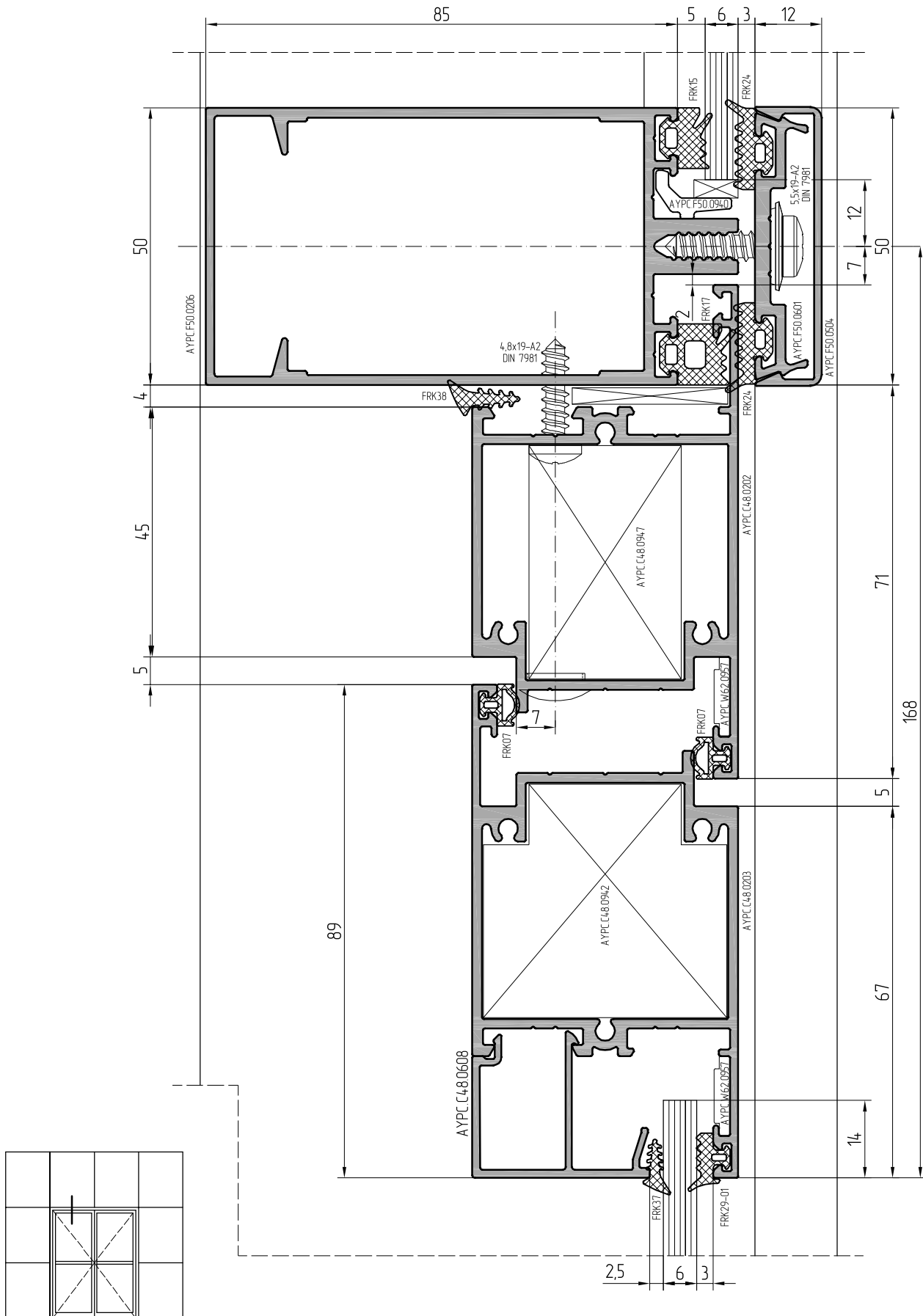

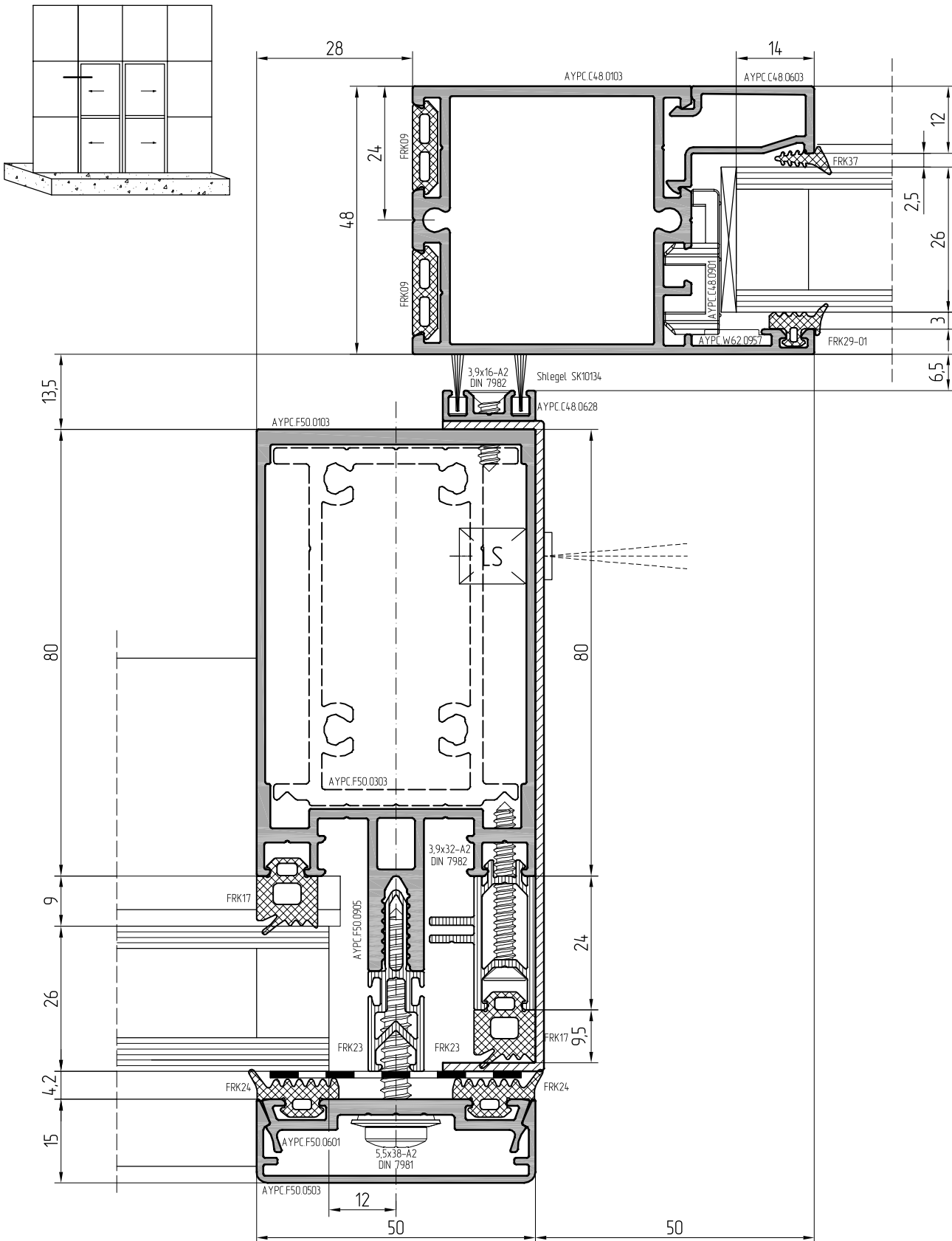



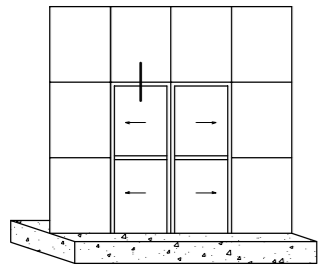

DORMA ES200

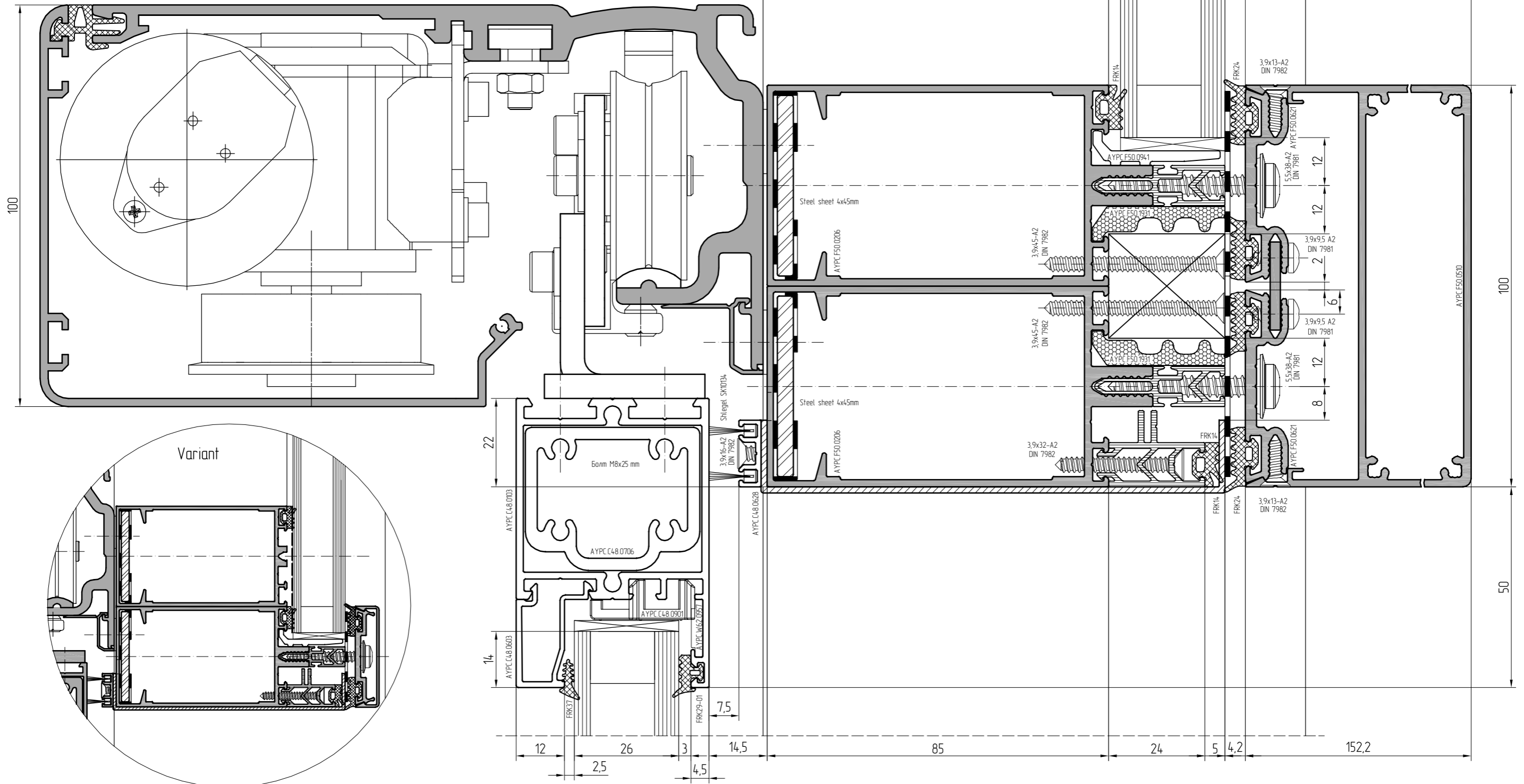





**ALUFACH ALT F50**  
CURTAIN WALL  
SYSTEM

# ASSEMBLAGE AND INSTALLATION



Notch connection of mullion and transom without joining element

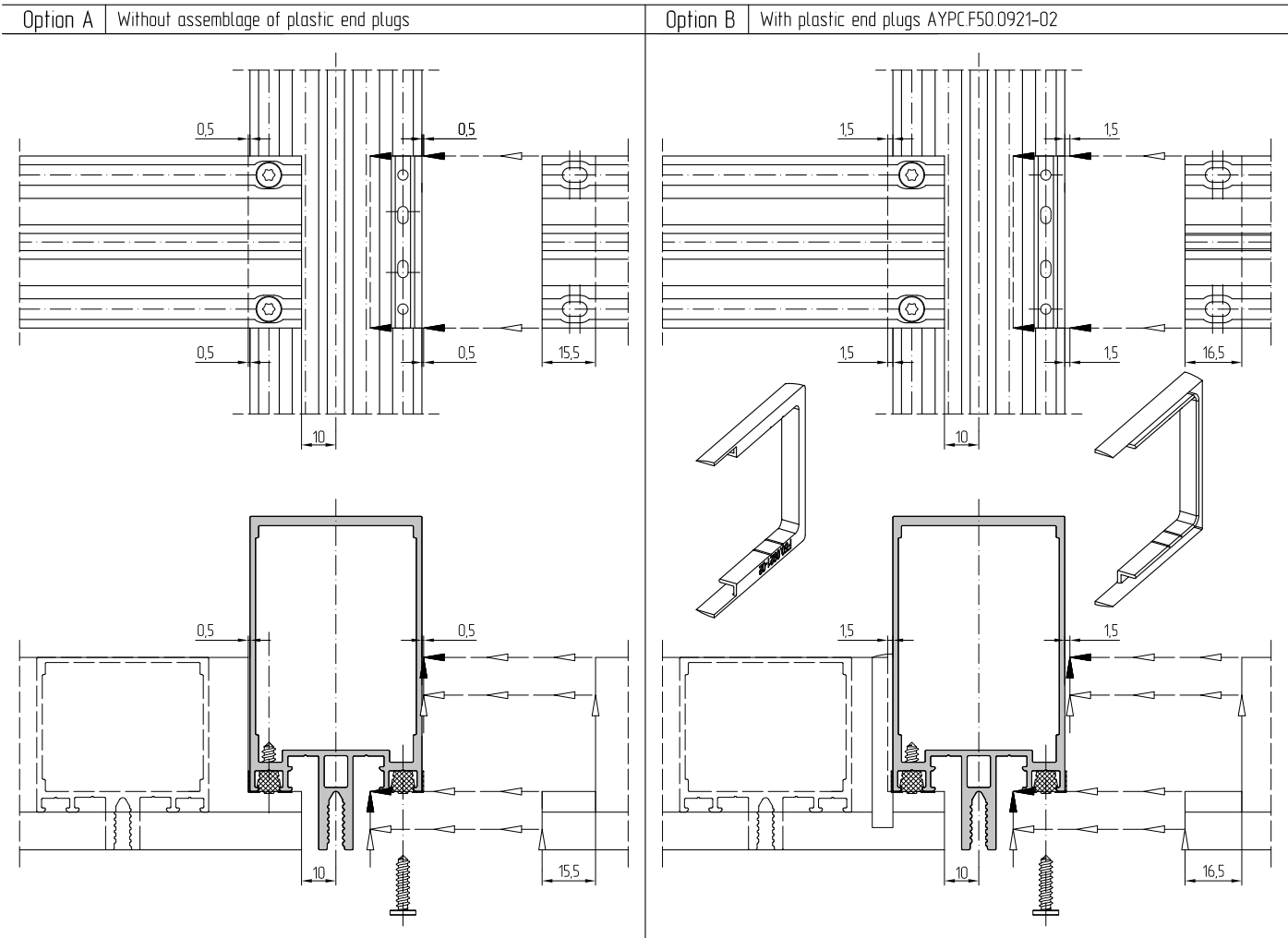
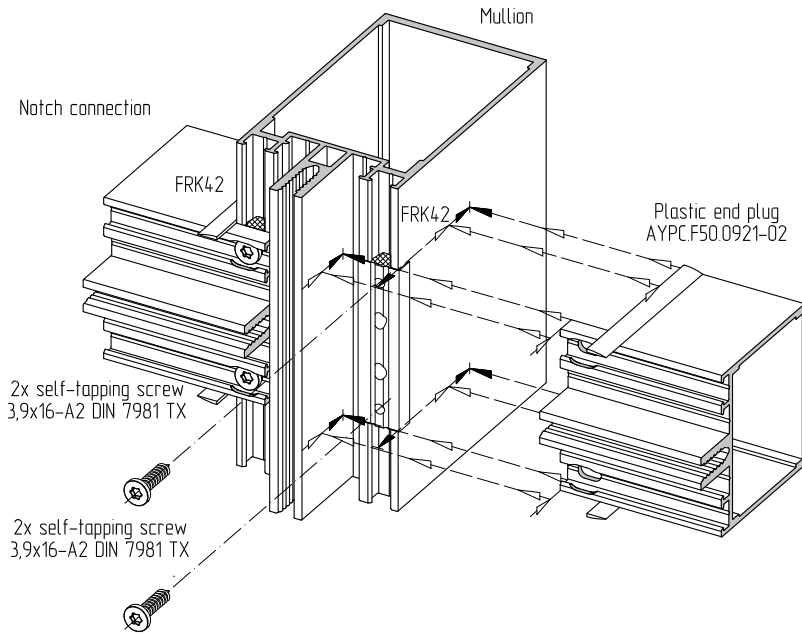

Notch connection of mullion and transom with help of a joining element

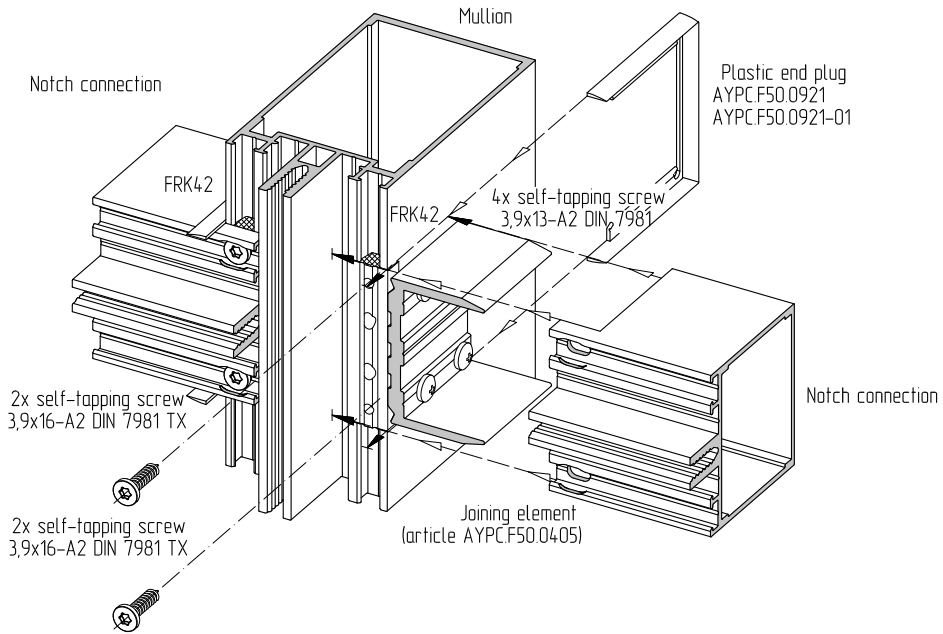

Option A   Without assemblage of plastic end plugs	Option B   With plastic end plugs AYPC.F50.0921/AYPC.F50.0921-01

Notch connection of mullion and transom with help of a joining element

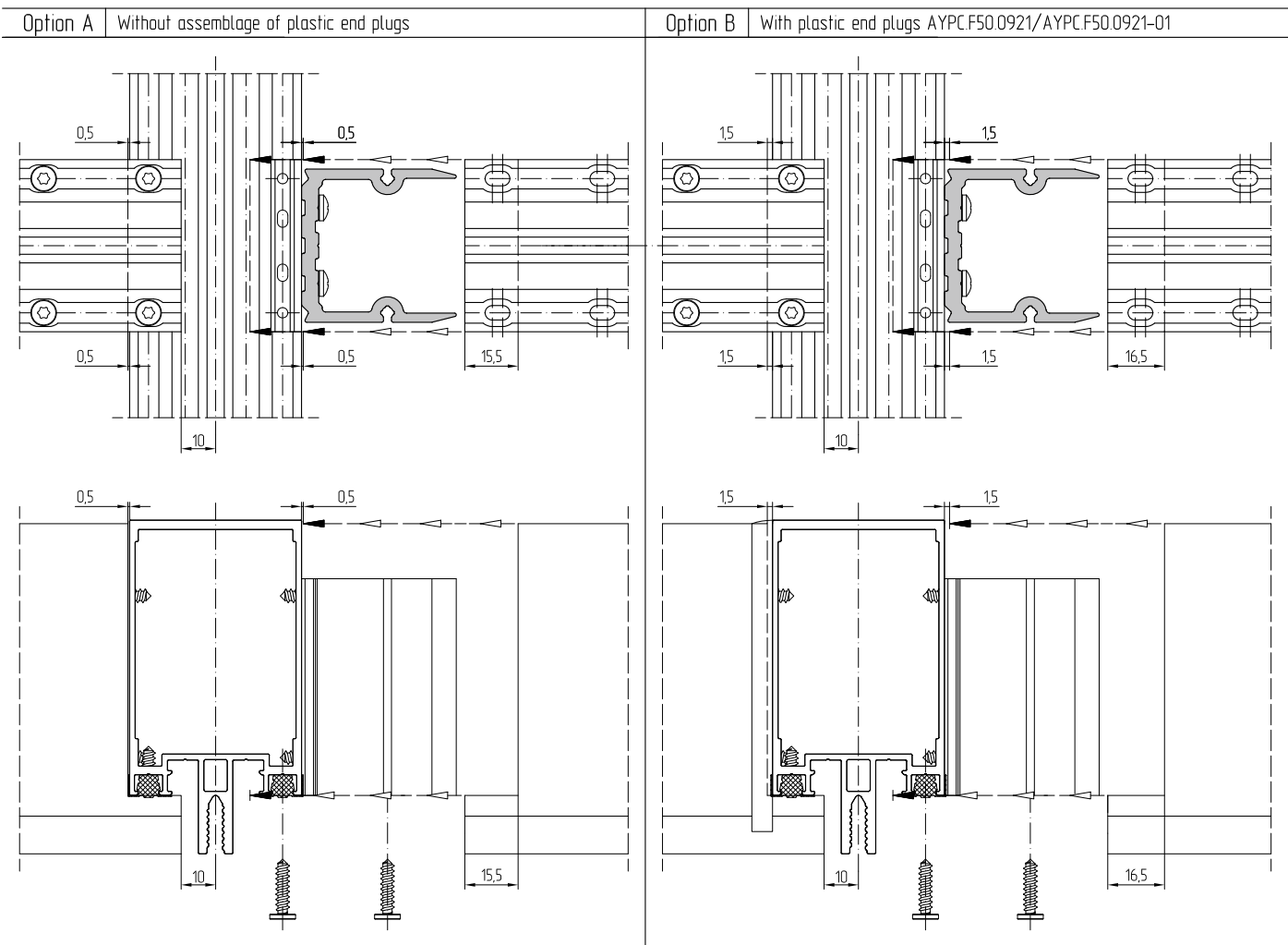
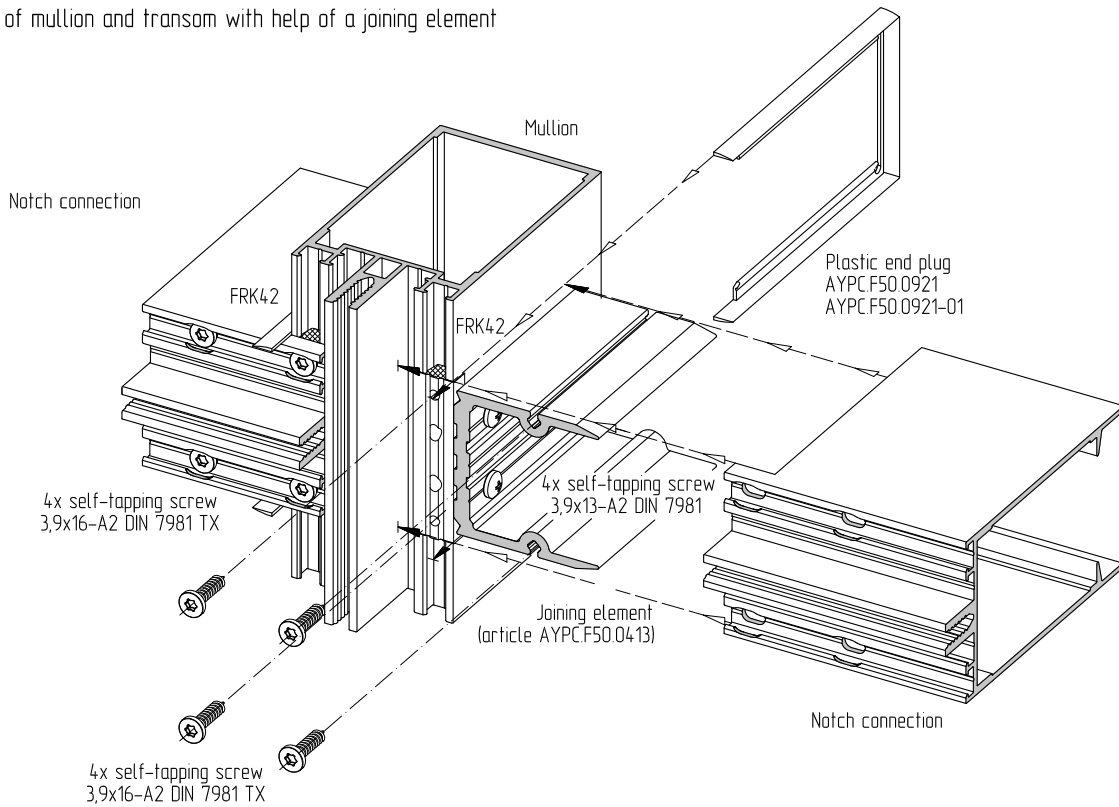

Notch connection of mullion and transom with help of a joining element

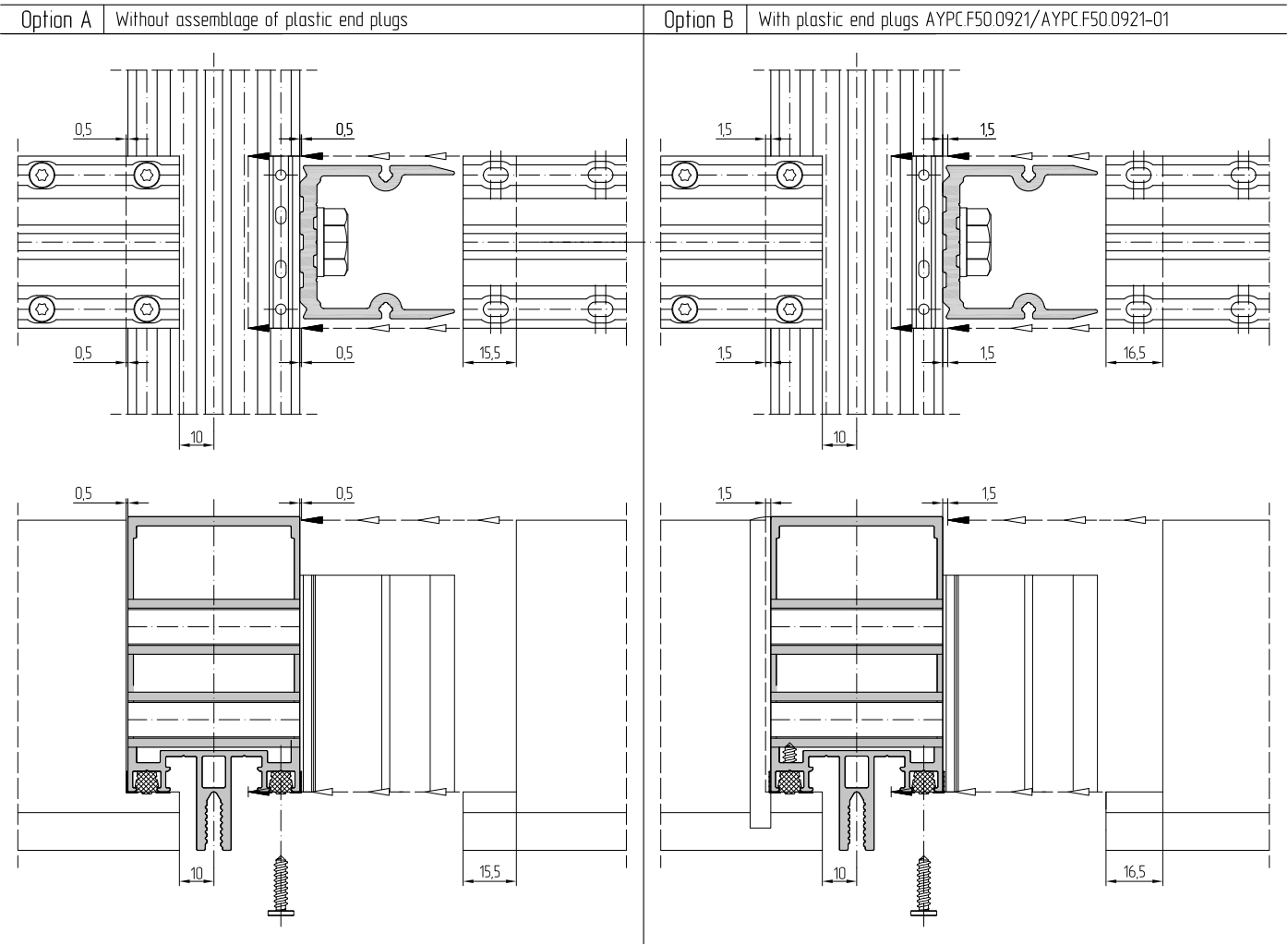
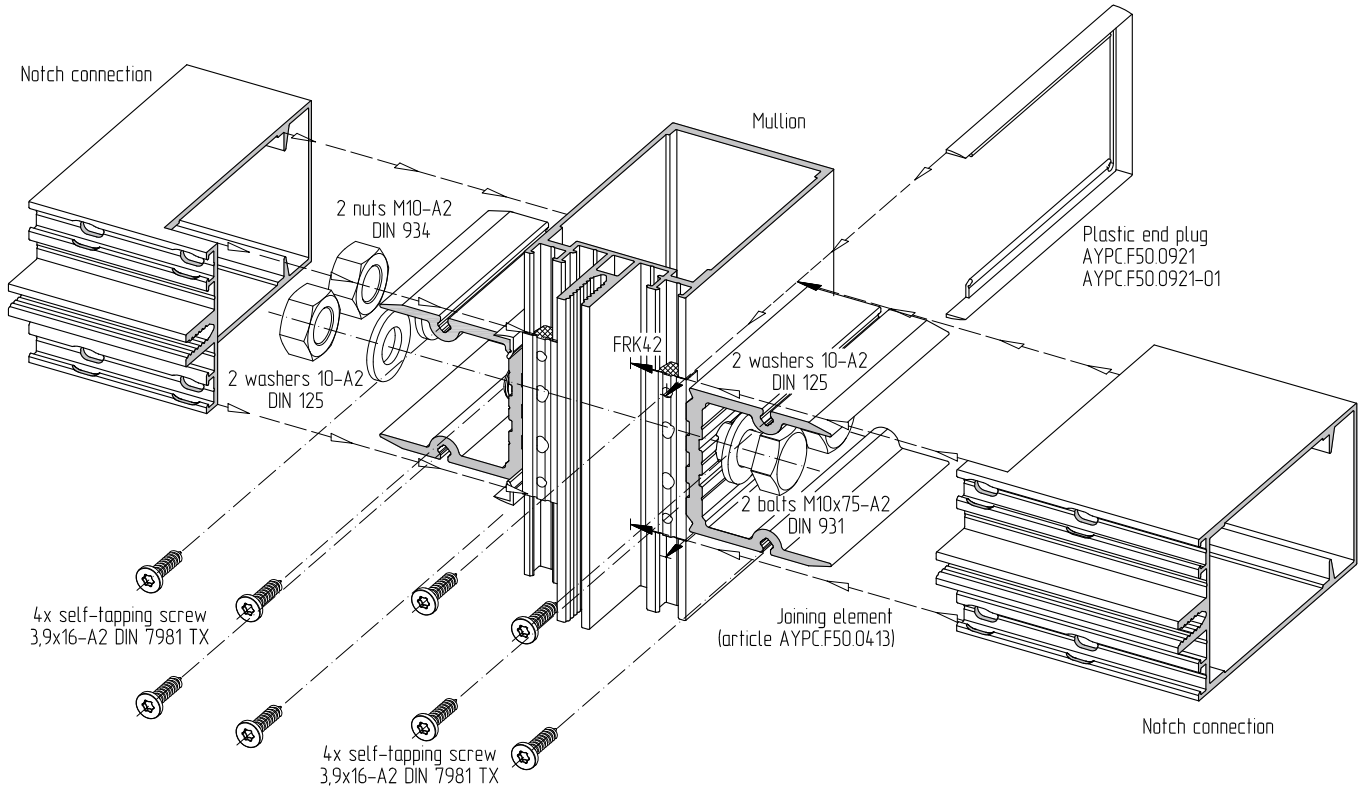



Notch connection of mullion and transom with help of a joining element

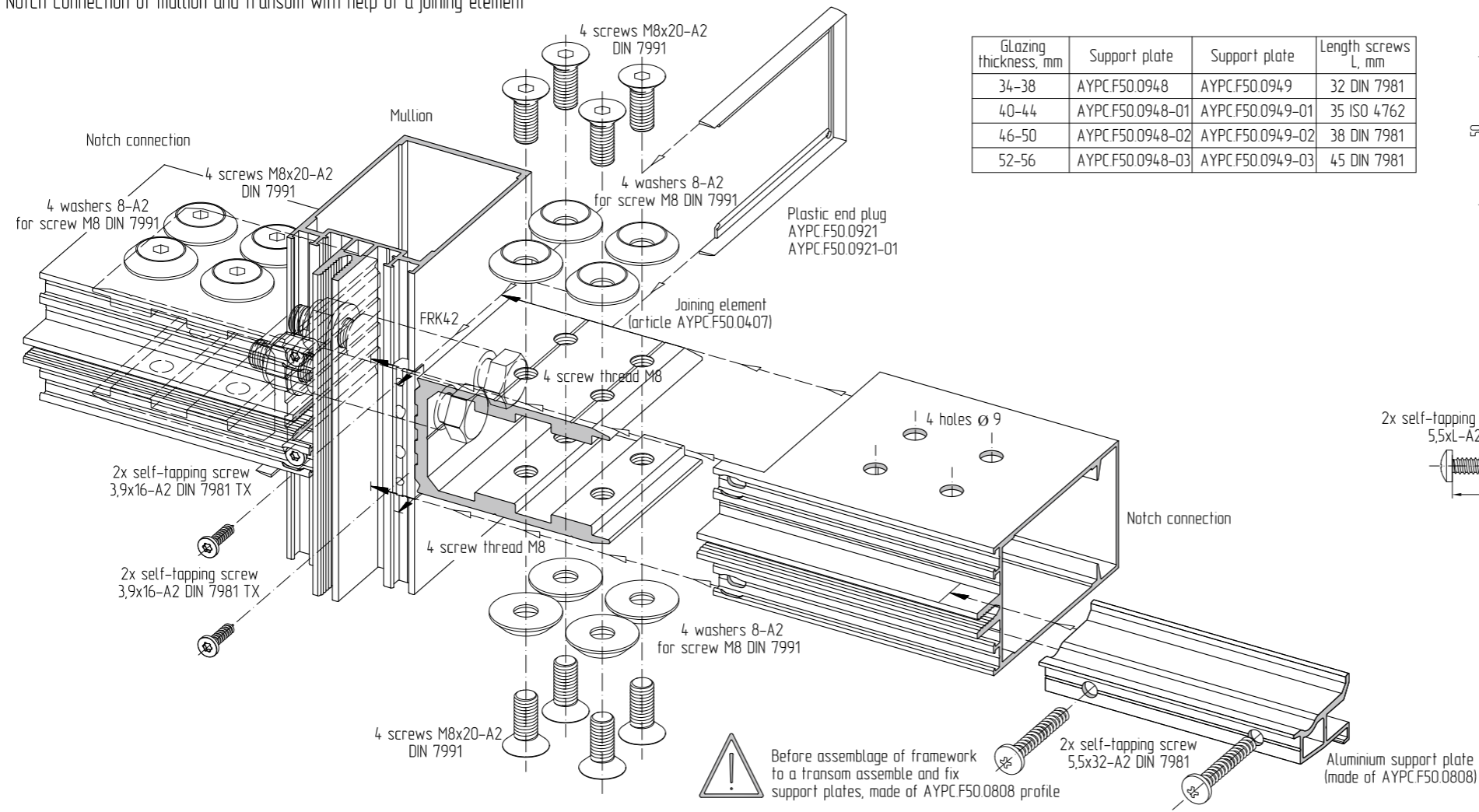

Glazing thickness, mm	Support plate	Support plate	Length screws L, mm
34-38	AYPC.F50.0948	AYPC.F50.0949	32 DIN 7981
40-44	AYPC.F50.0948-01	AYPC.F50.0949-01	35 ISO 4762
46-50	AYPC.F50.0948-02	AYPC.F50.0949-02	38 DIN 7981
52-56	AYPC.F50.0948-03	AYPC.F50.0949-03	45 DIN 7981

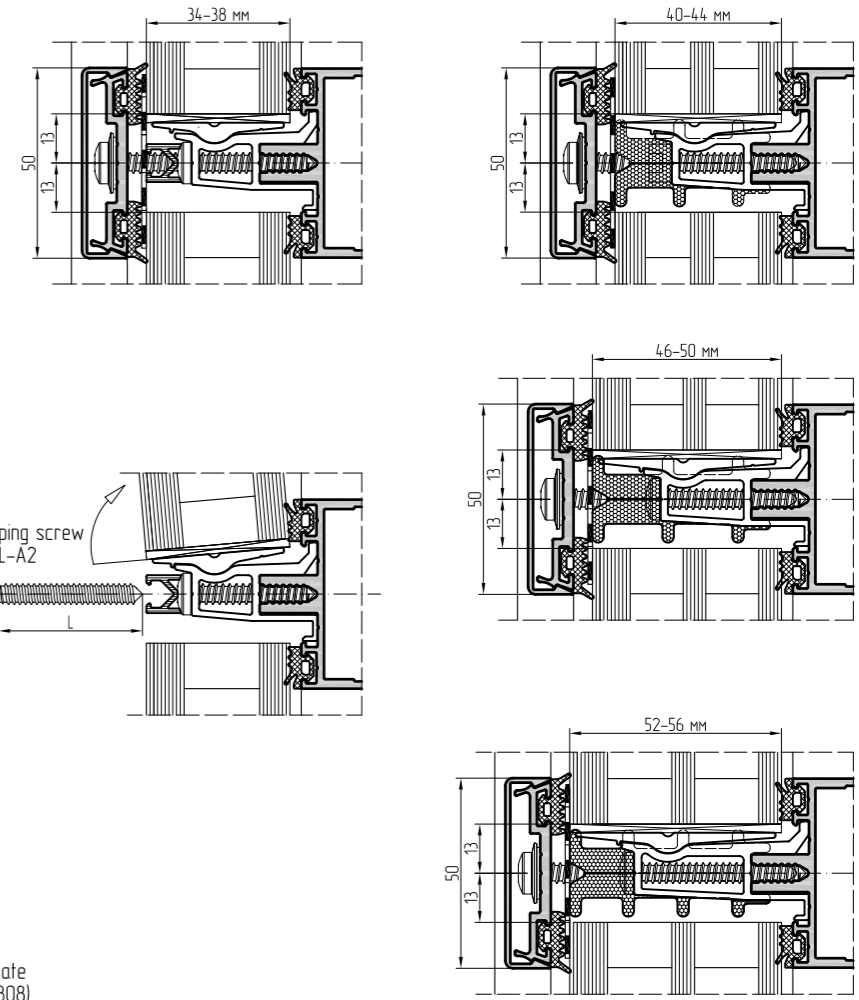

Option A Without assemblage of plastic end plugs

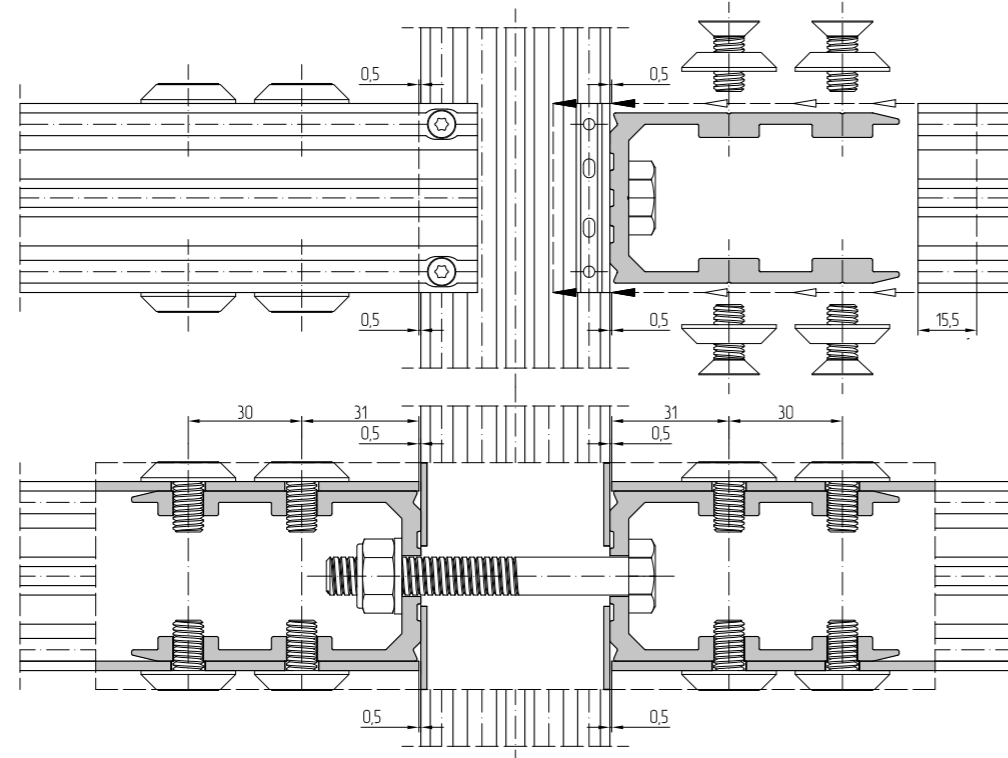

Option B With plastic end plugs AYPC.F50.0921, AYPC.F50.0921-01

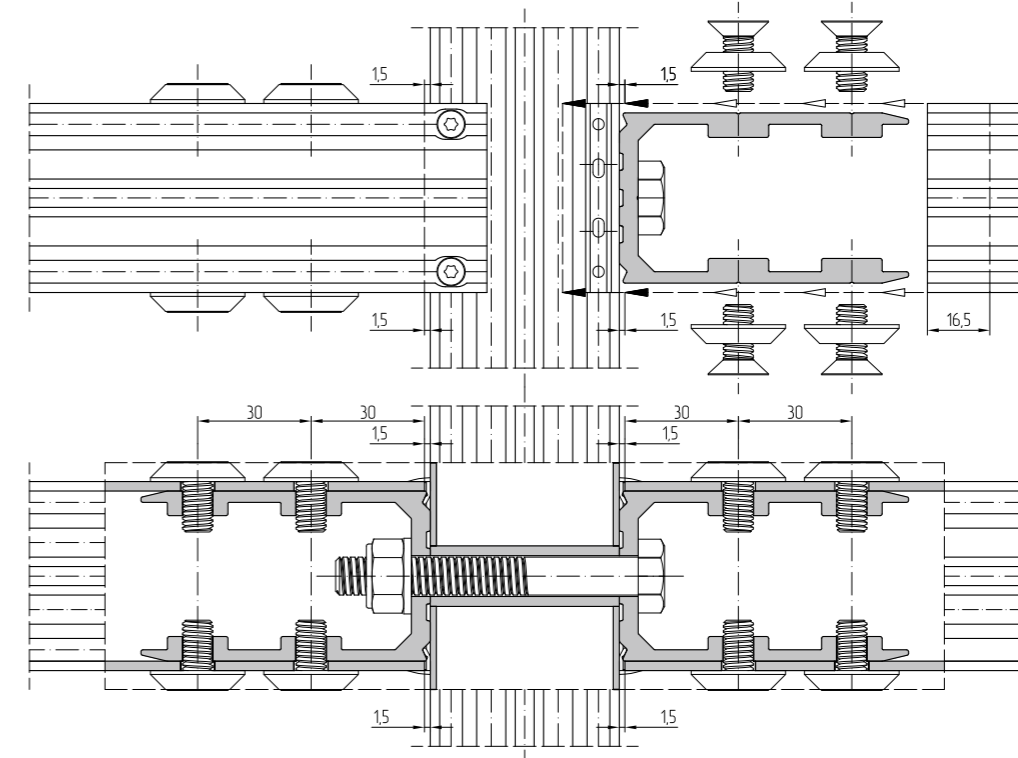

Notch connection of mullion and transom with help of a joining element

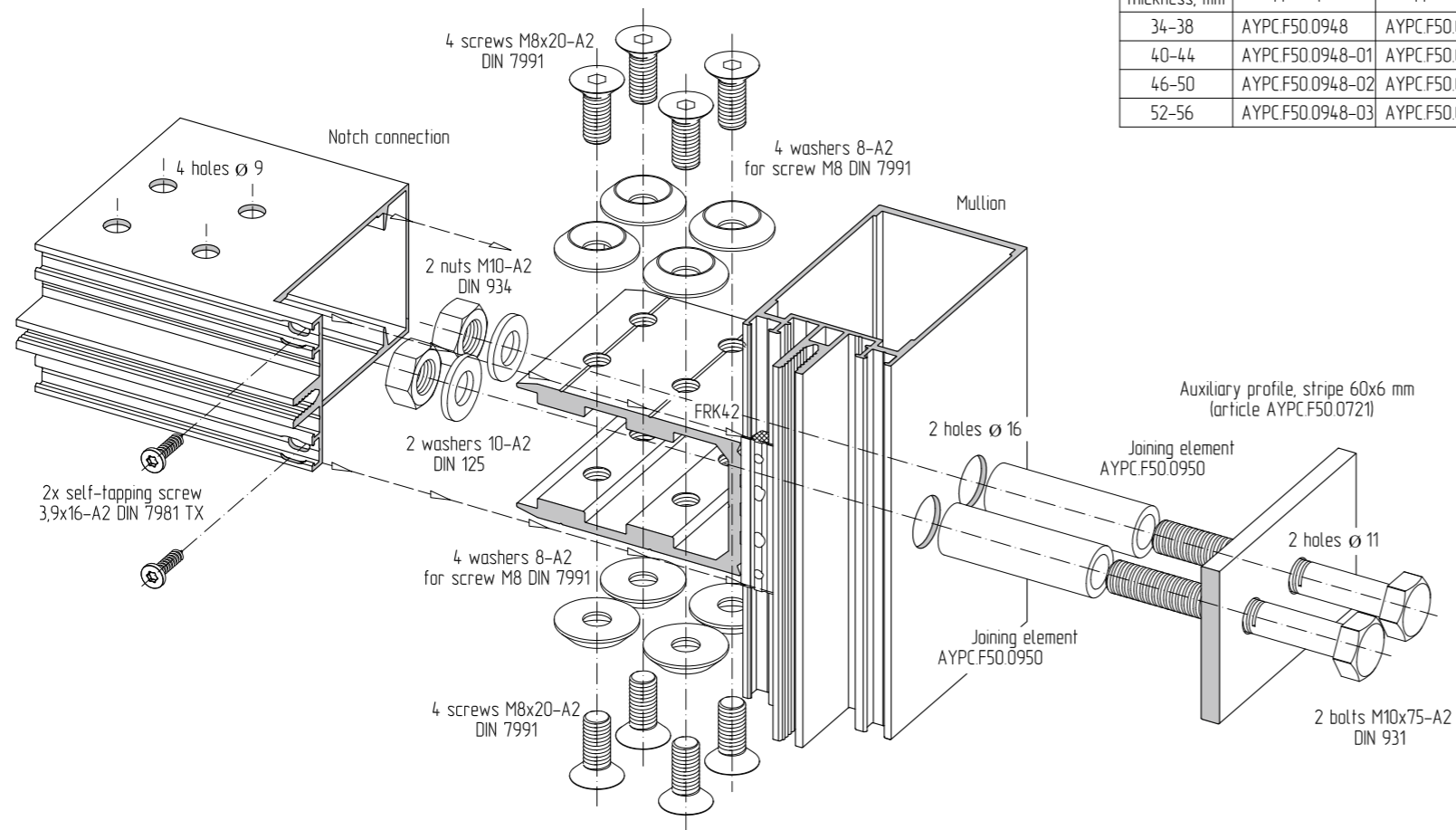

Glazing thickness, mm	Support plate	Support plate	Length screws L, mm
34-38	AYPC.F50.0948	AYPC.F50.0949	32 DIN 7981
40-44	AYPC.F50.0948-01	AYPC.F50.0949-01	35 ISO 4762
46-50	AYPC.F50.0948-02	AYPC.F50.0949-02	38 DIN 7981
52-56	AYPC.F50.0948-03	AYPC.F50.0949-03	45 DIN 7981

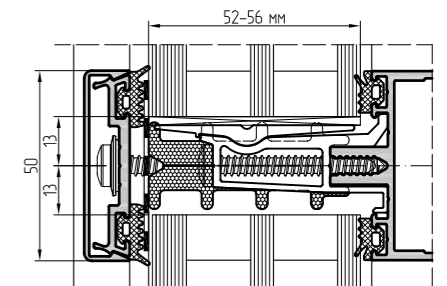
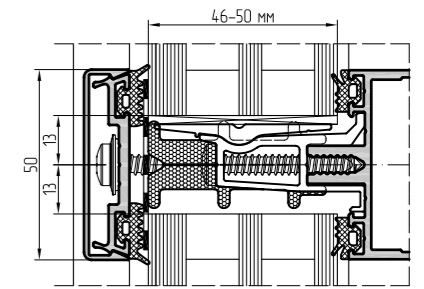
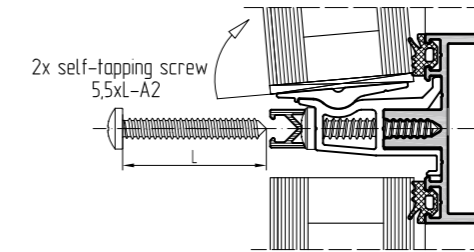
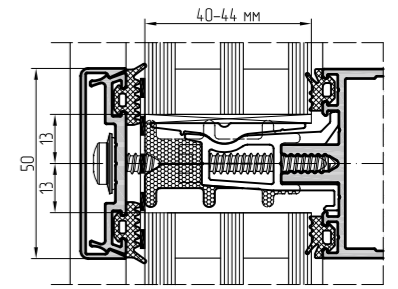
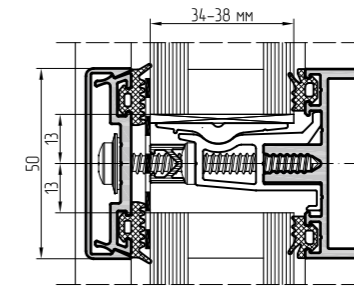

Option A Without assemblage of plastic end plugs

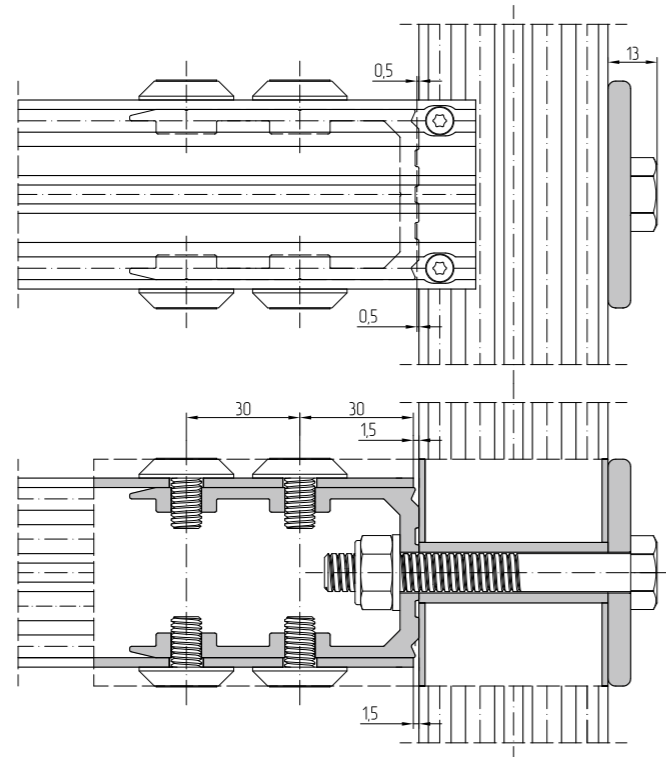

Option B With plastic end plugs AYP.C.F50.0921, AYP.C.F50.0921-01

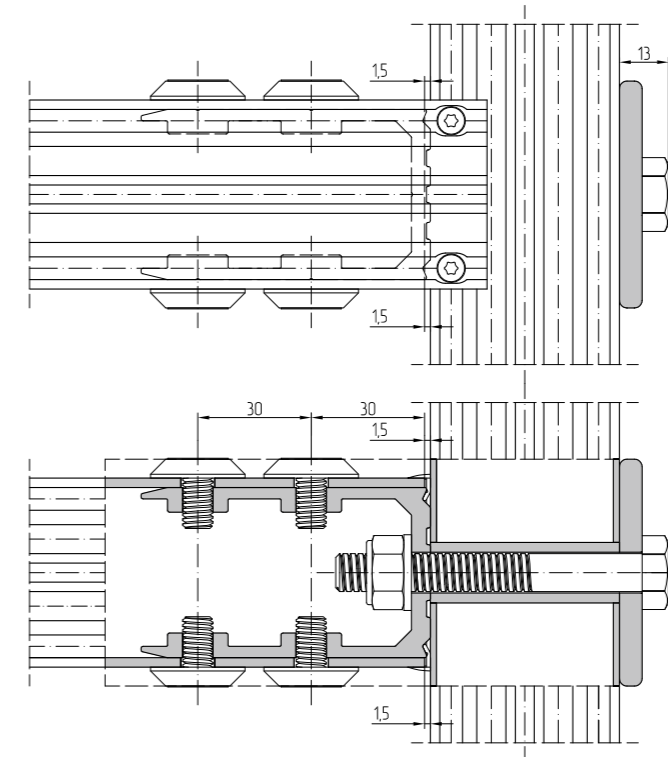

Notch connection of mullion and transom with help of a joining element and reinforcing profile

Glazing thickness, mm	Support plate	Support plate	Length screws L, mm
34-38	AYPC.F50.0948	AYPC.F50.0949	32 DIN 7981
40-44	AYPC.F50.0948-01	AYPC.F50.0949-01	35 ISO 4762
46-50	AYPC.F50.0948-02	AYPC.F50.0949-02	38 DIN 7981
52-56	AYPC.F50.0948-03	AYPC.F50.0949-03	45 DIN 7981

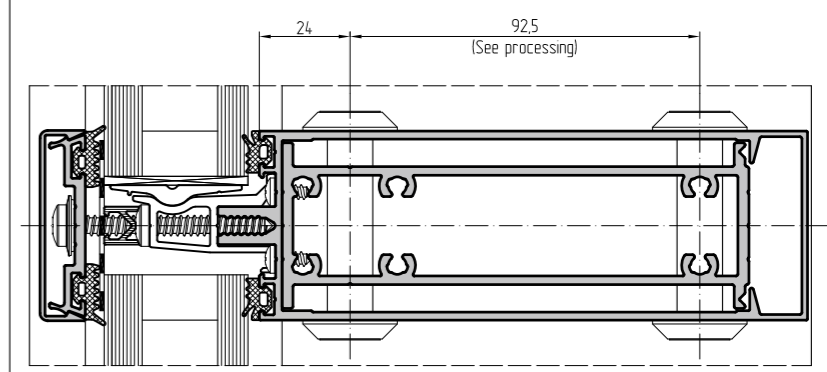
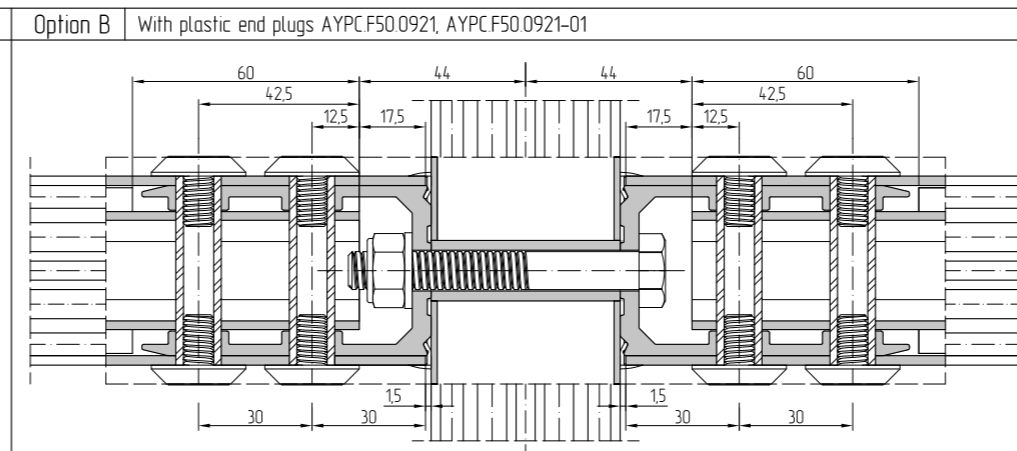
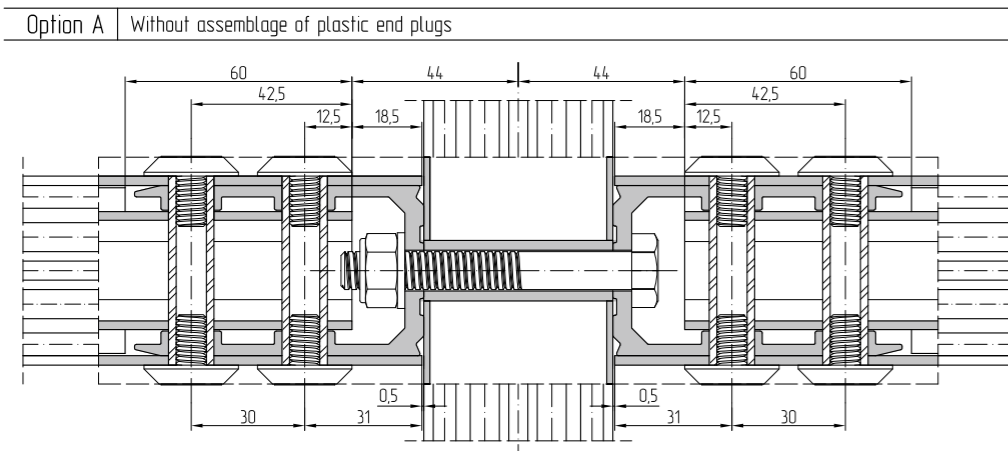
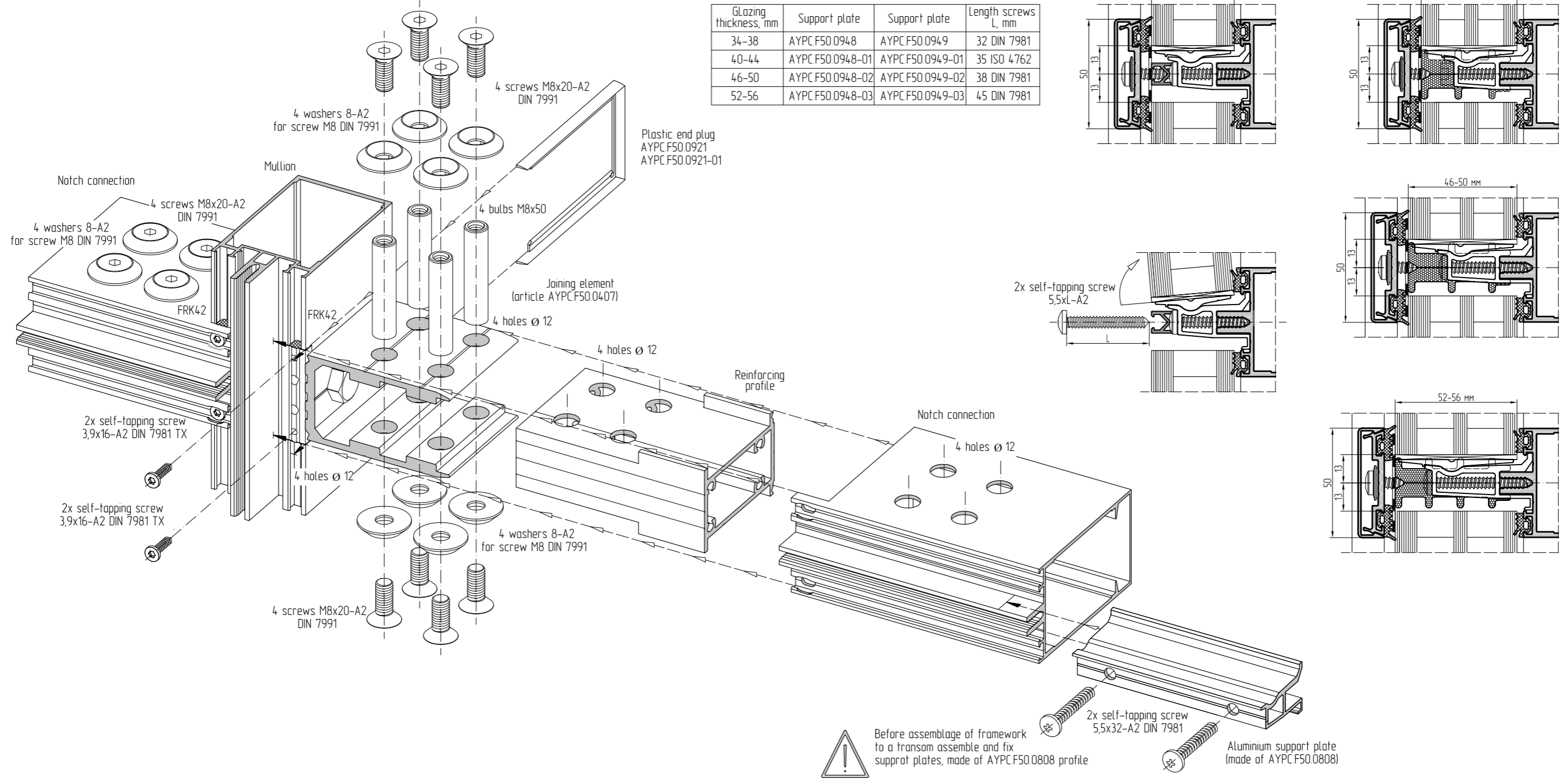



Installation of AYPC.F50.0953 bearing plate for heavy-weight infill unit on the sweep angle

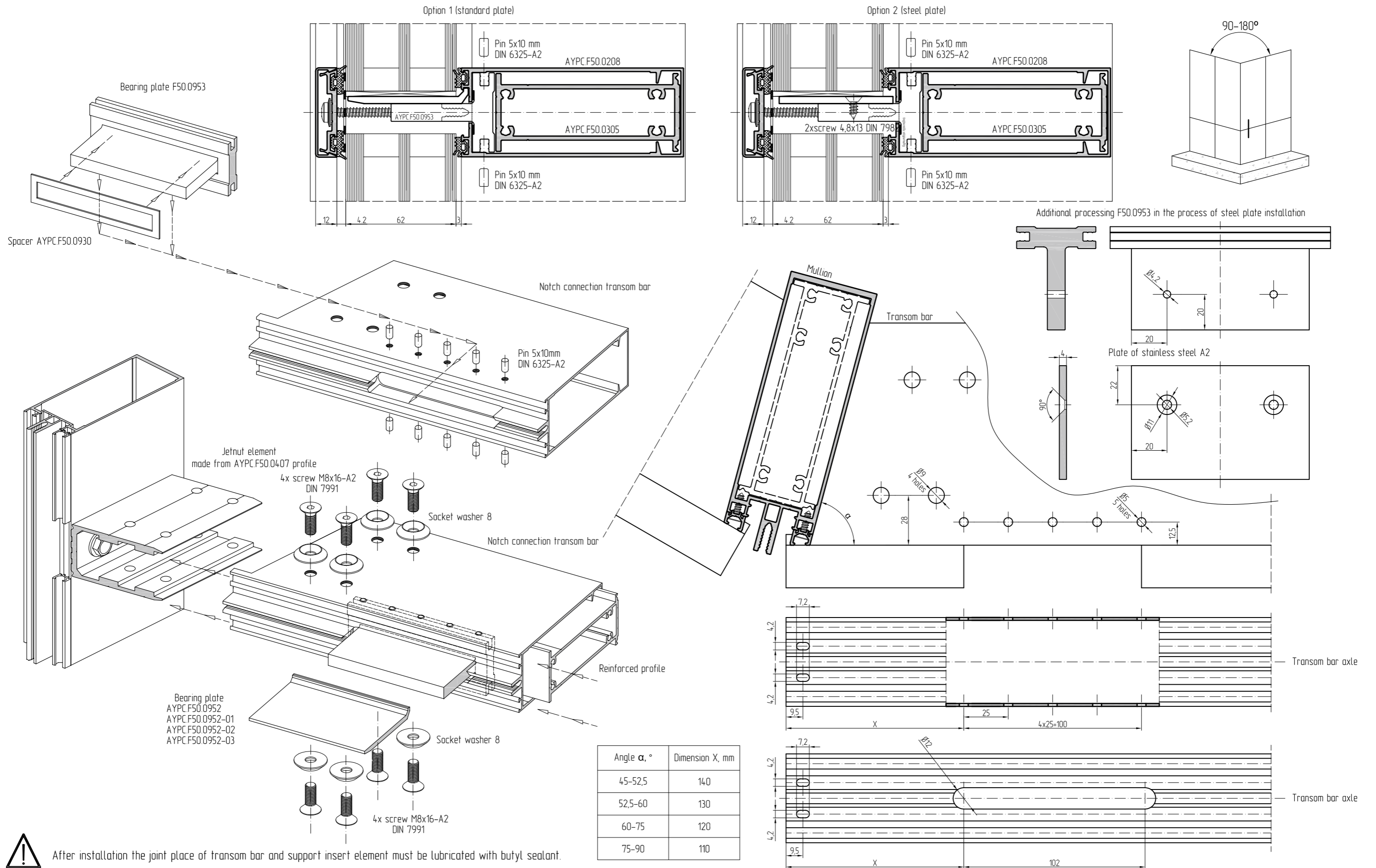

⚠ After installation the joint place of transom bar and support insert element must be lubricated with butyl sealant.

Notch connection of mullions and transoms with help of one joining element

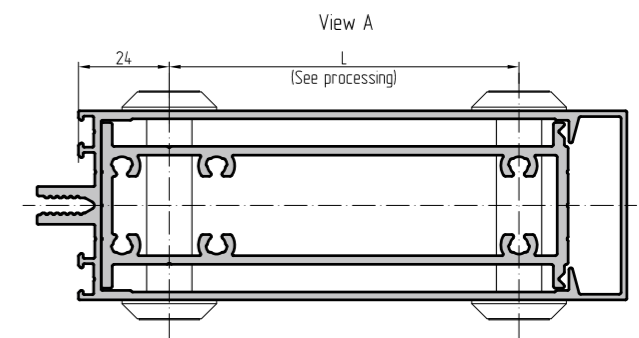
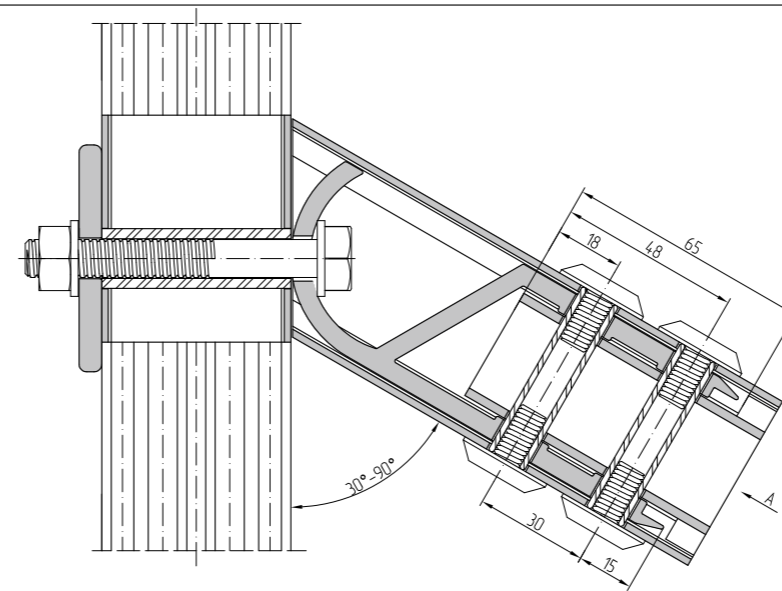
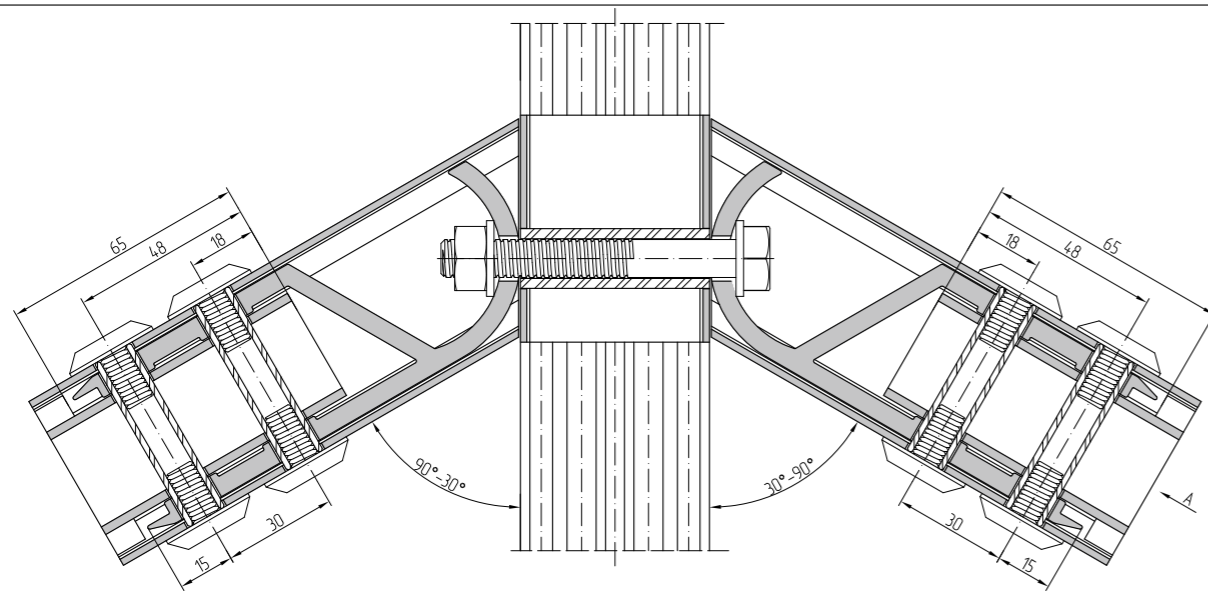
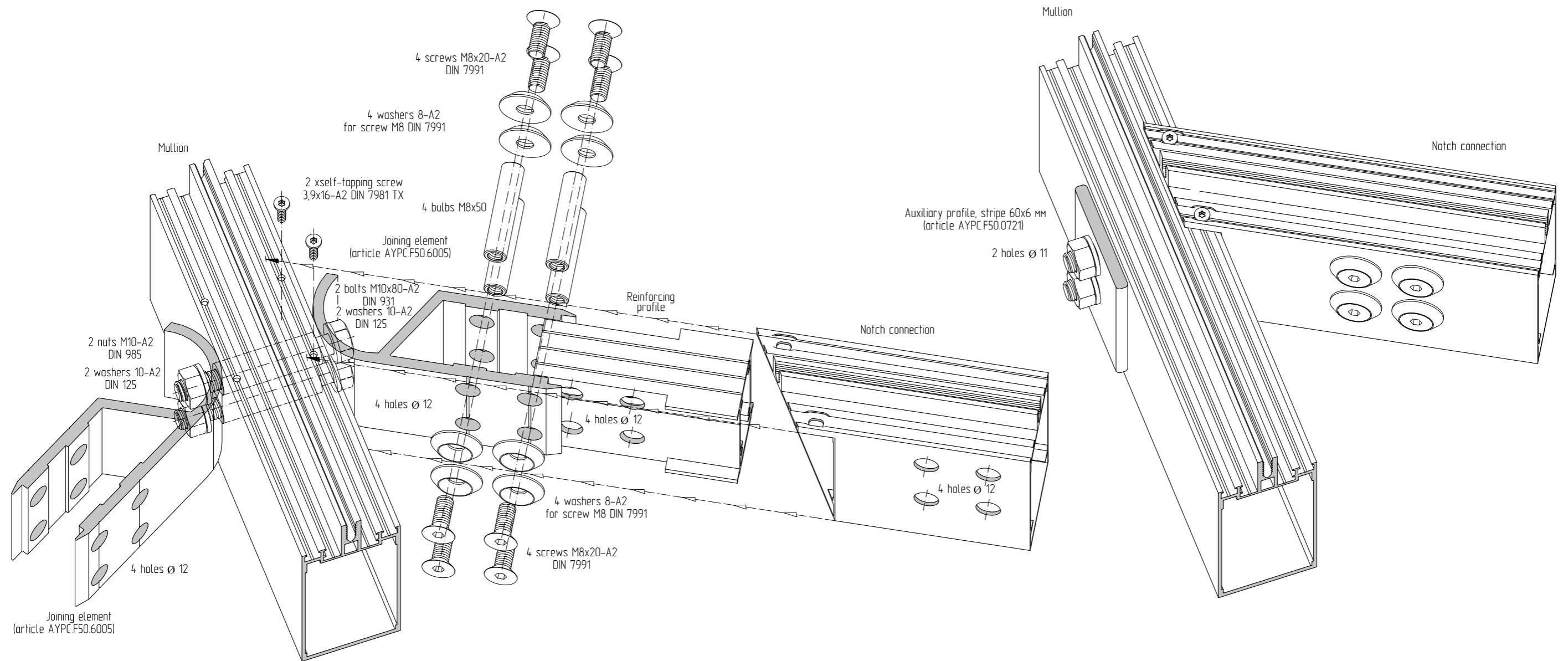



Notch connection of Mullions and transoms with help of a slide and one joining element

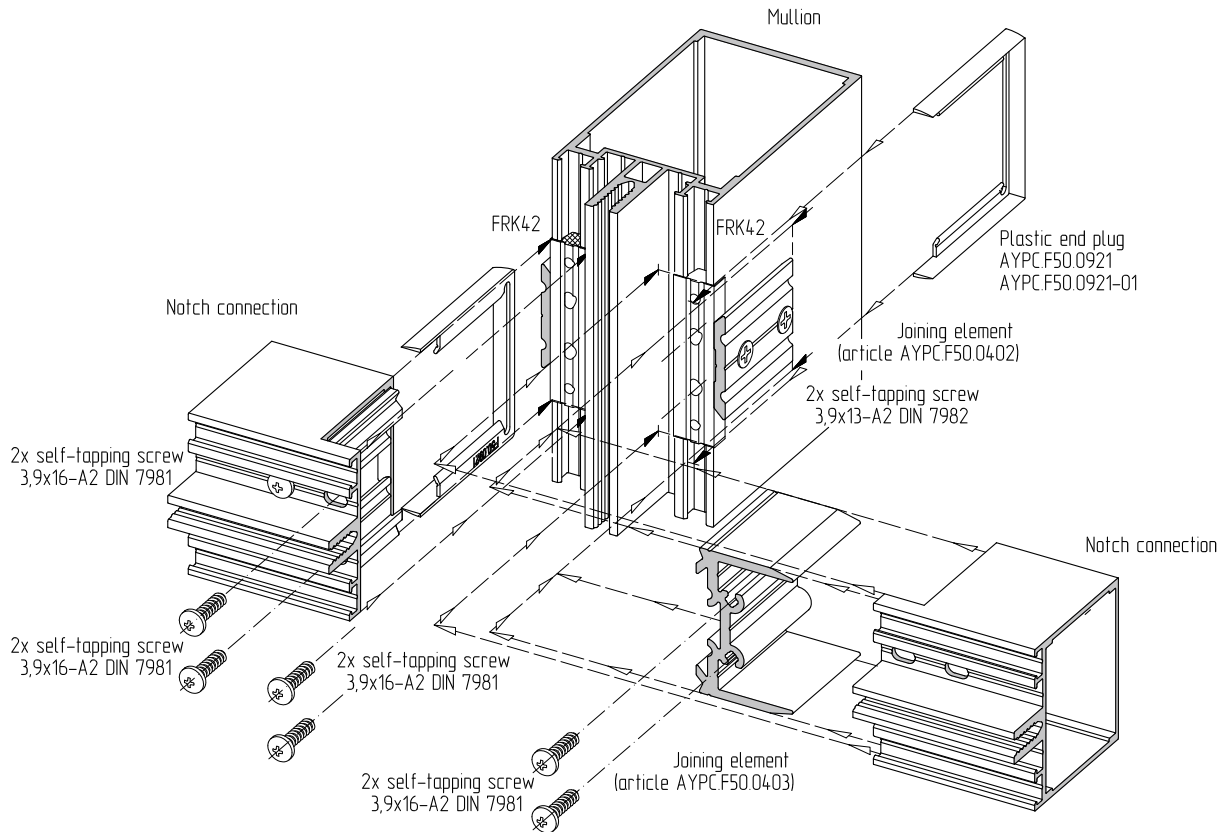

With plastic end plugs AYPC.F50.0921, AYPC.F50.0921-01

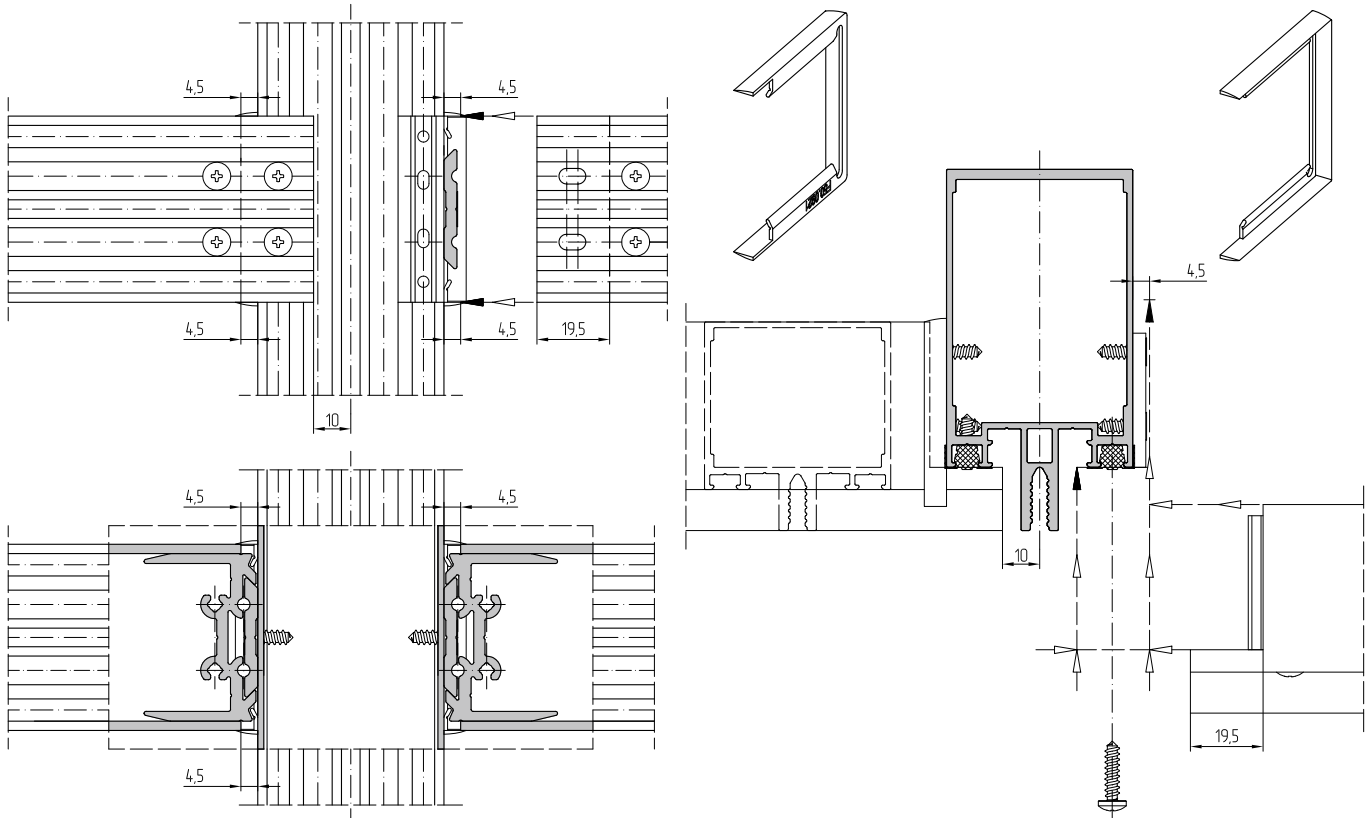

Notch connection of mullions and inclined transoms without joining element

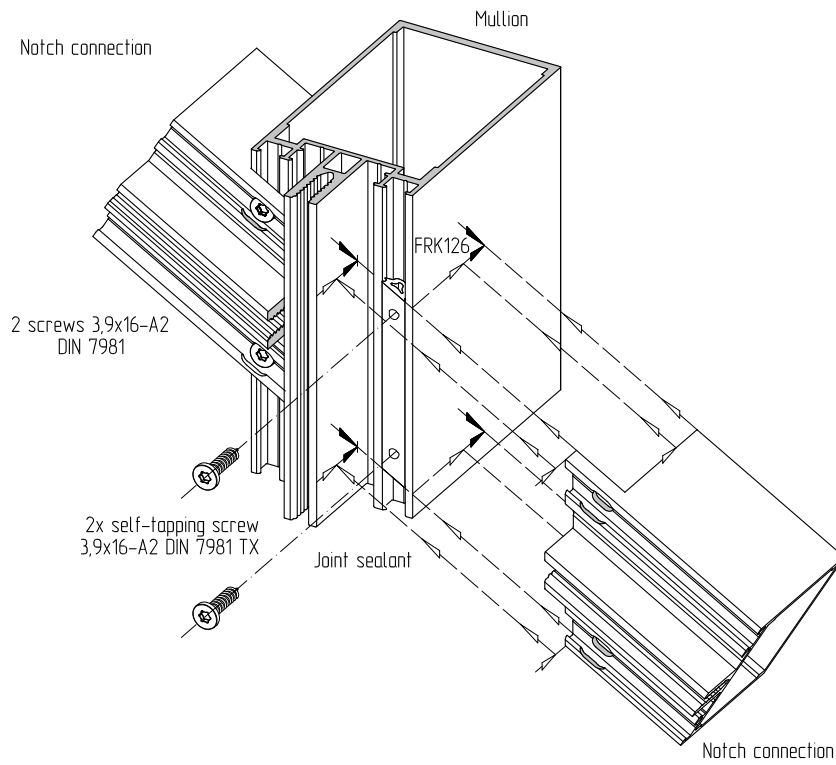

Without assemblage of plastic end plugs

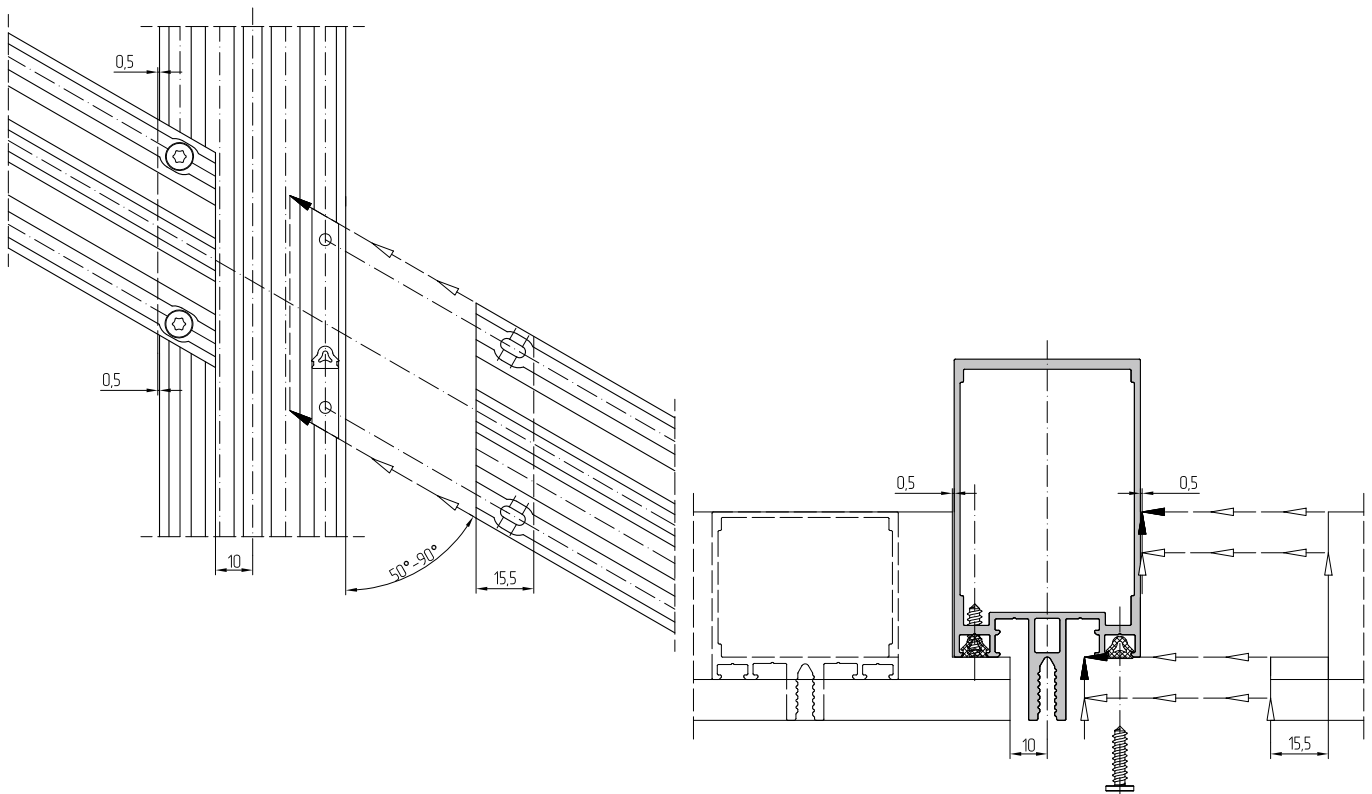



Notch connection of mullions and transoms with help of one joining element

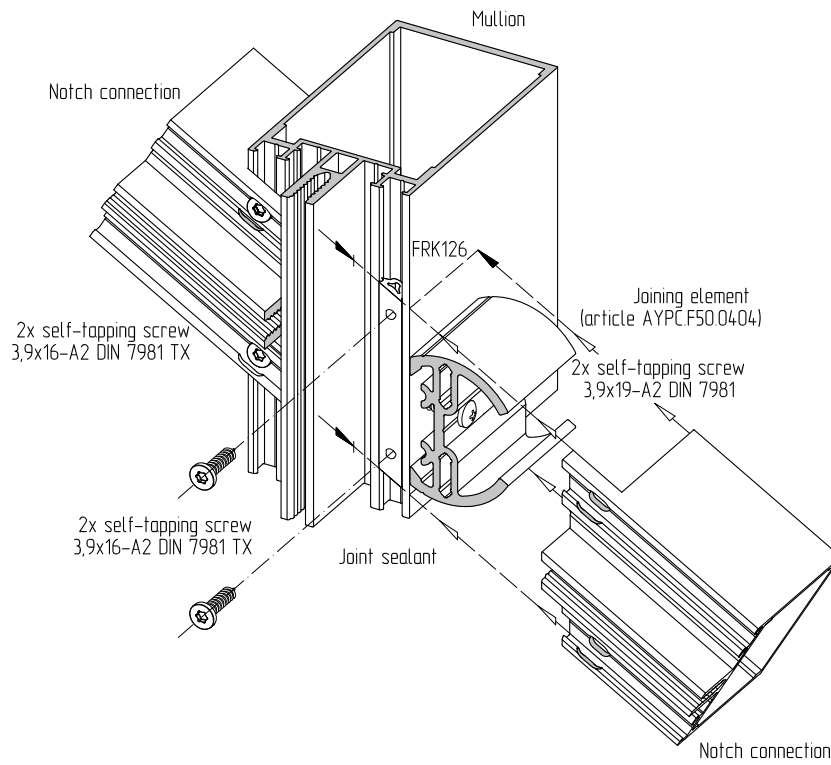

Without assemblage of plastic end plugs

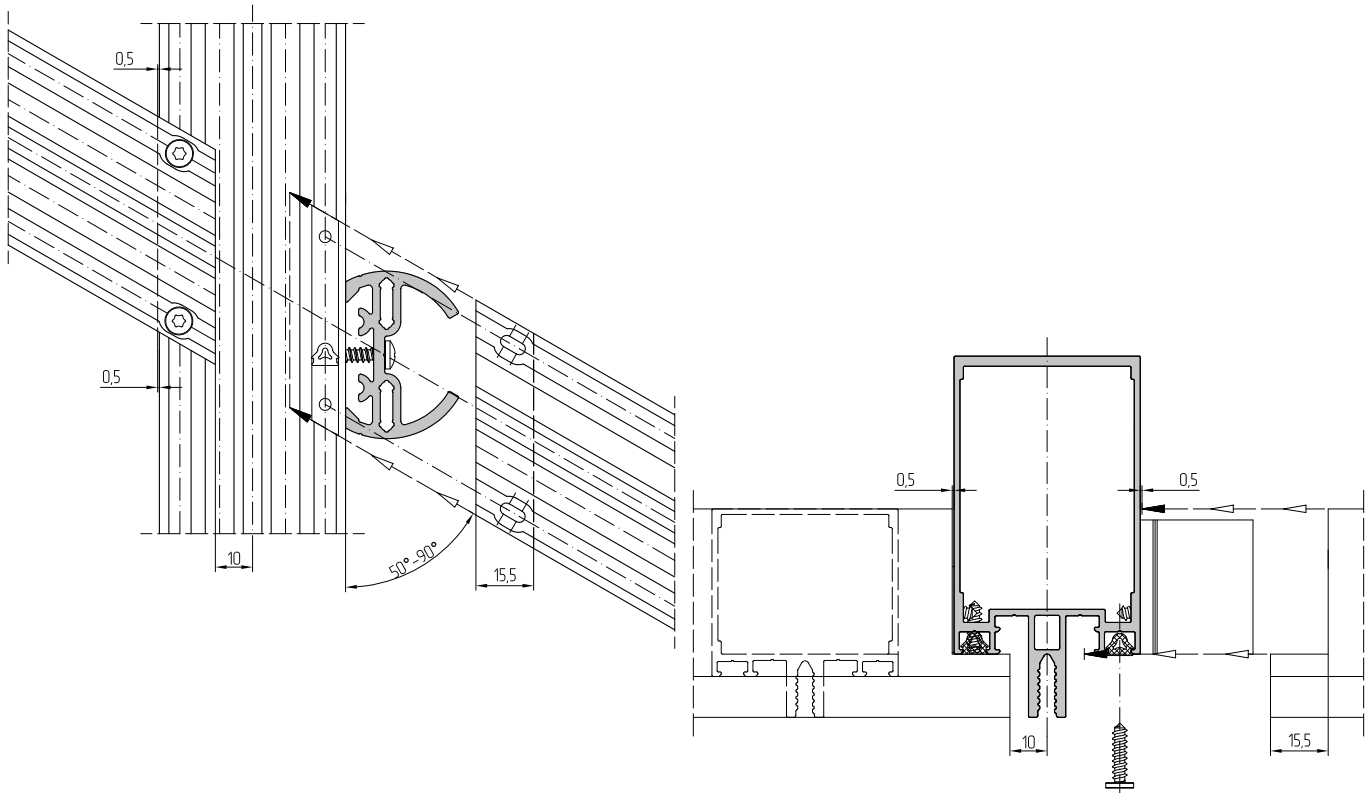

Notch connection of mullions and transoms with help of one joining element

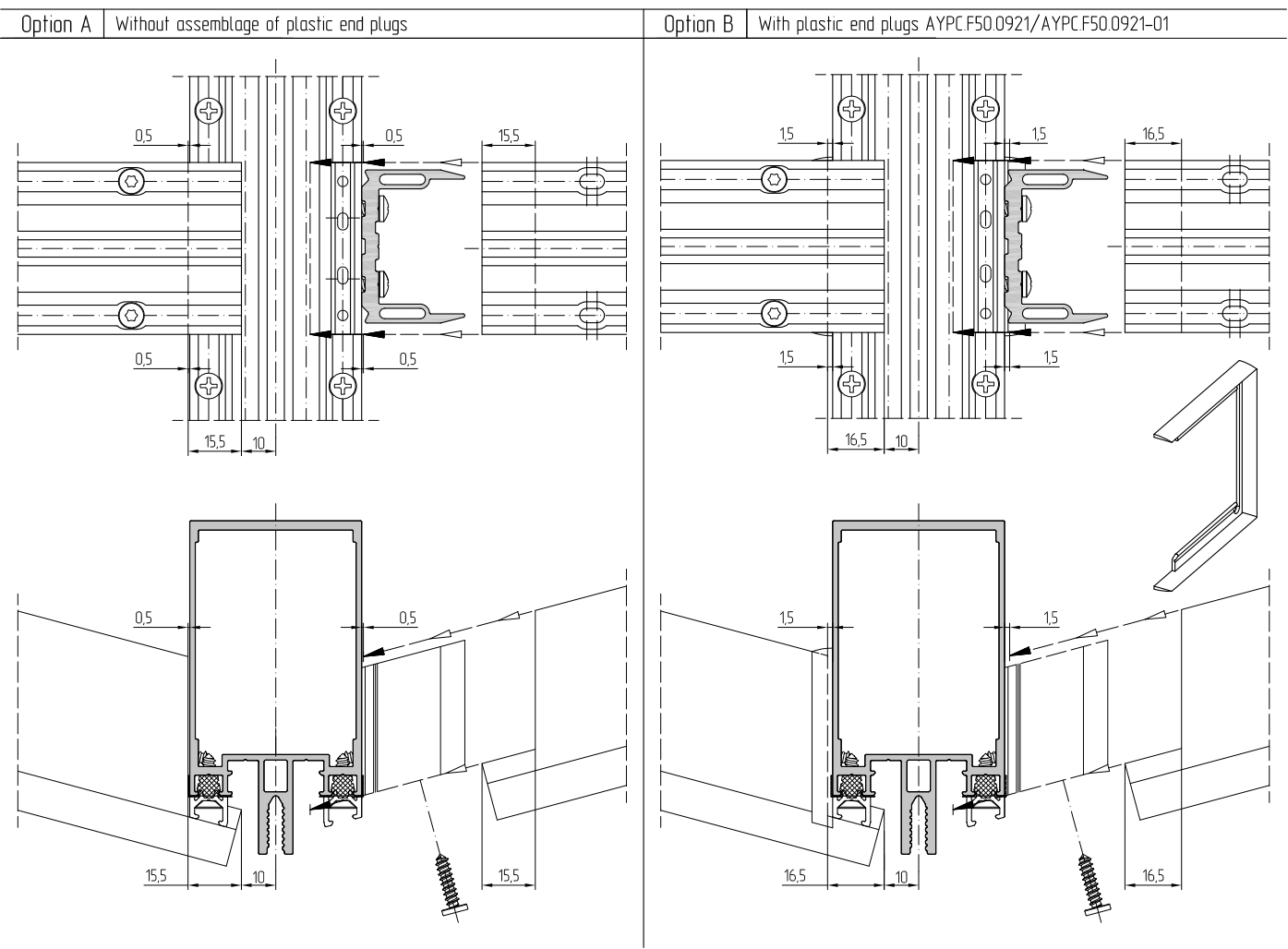
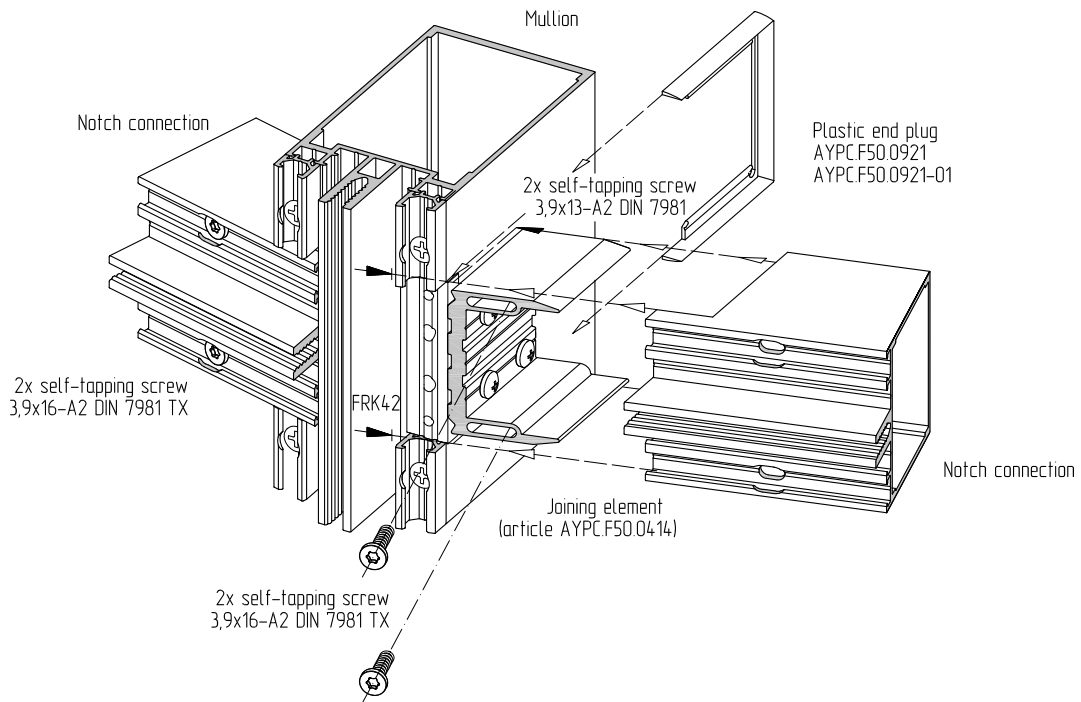

Shaped notch connection of mullions and transoms without joining element

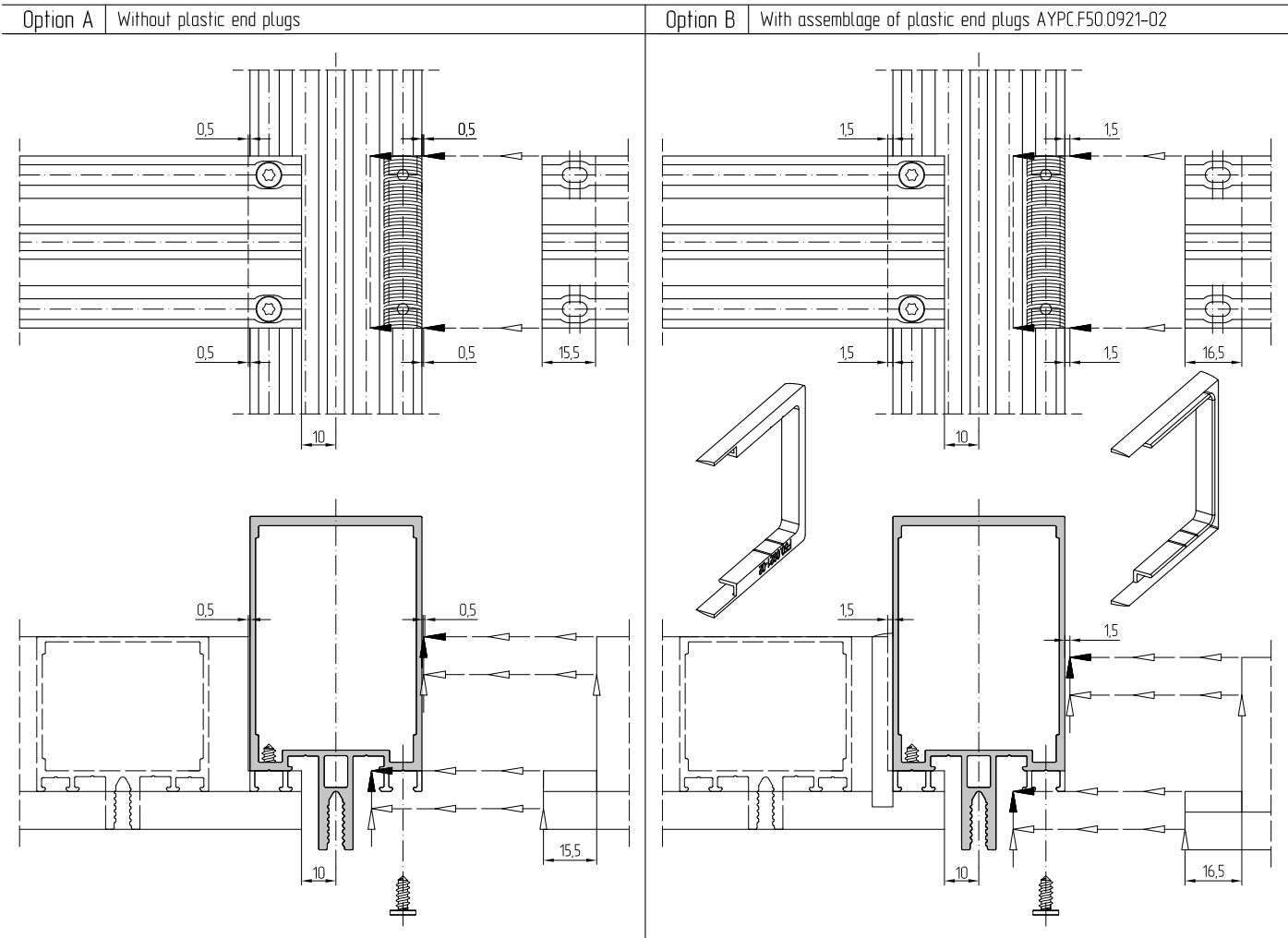
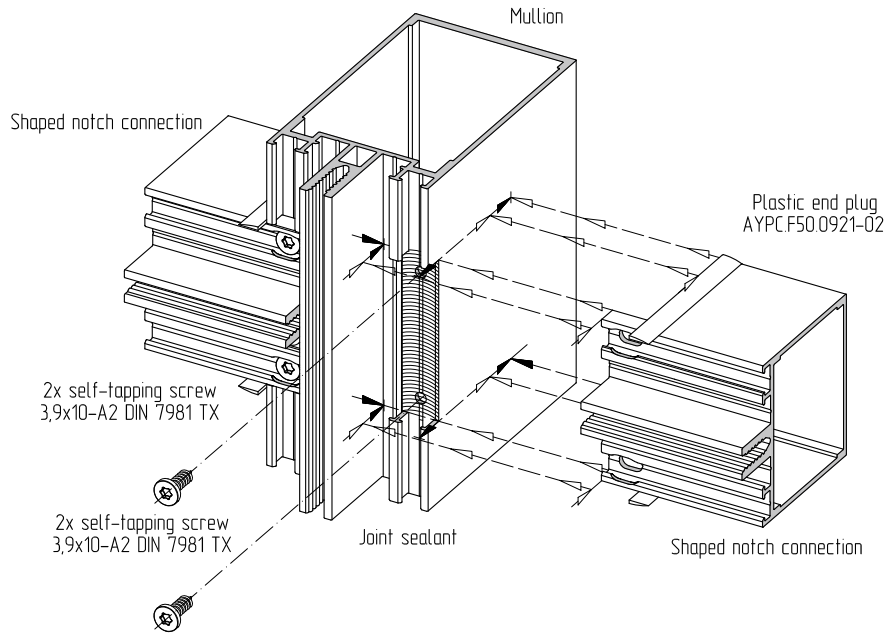

Shaped notch connection of mullions and transoms with help of joining element

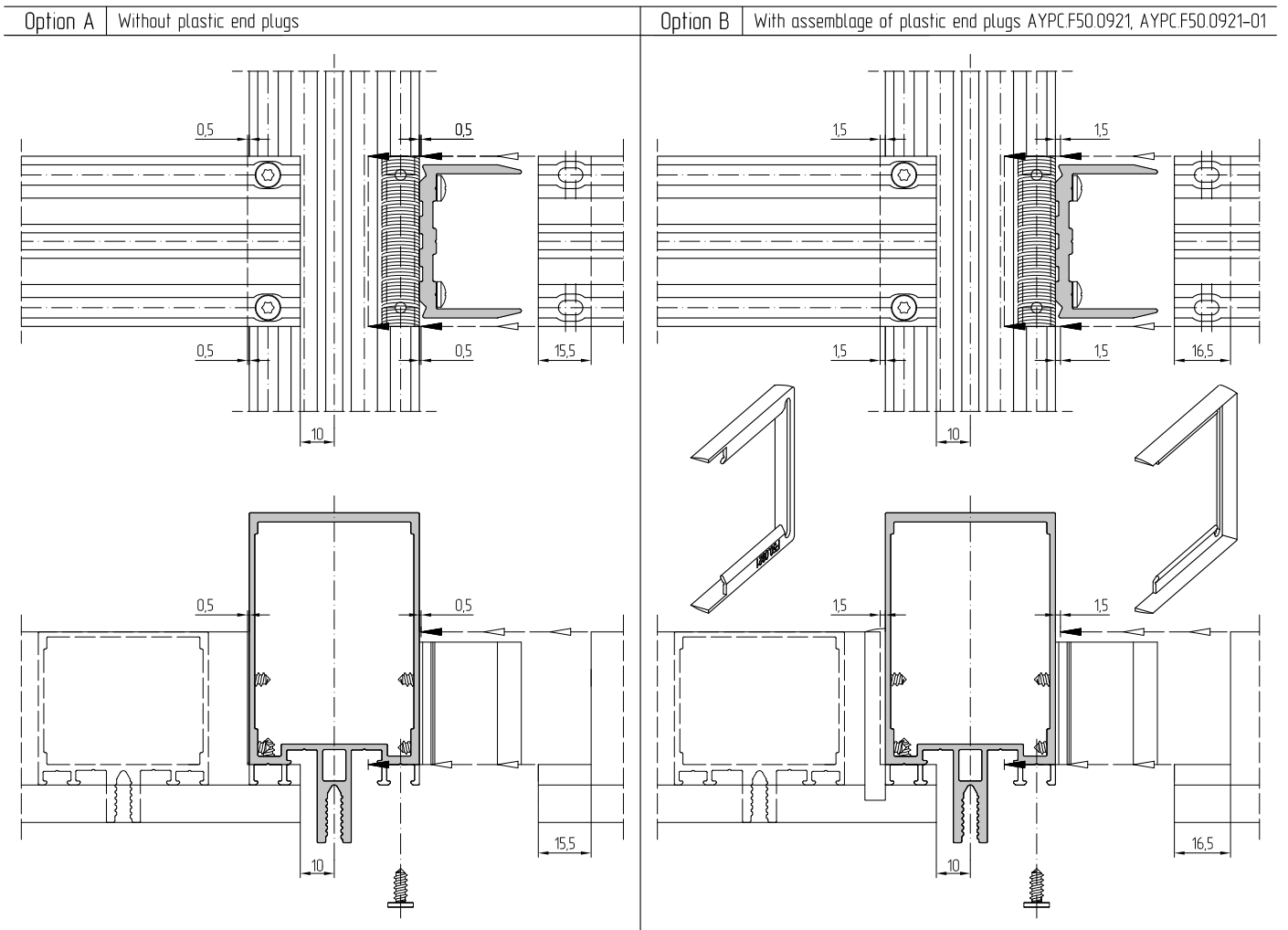
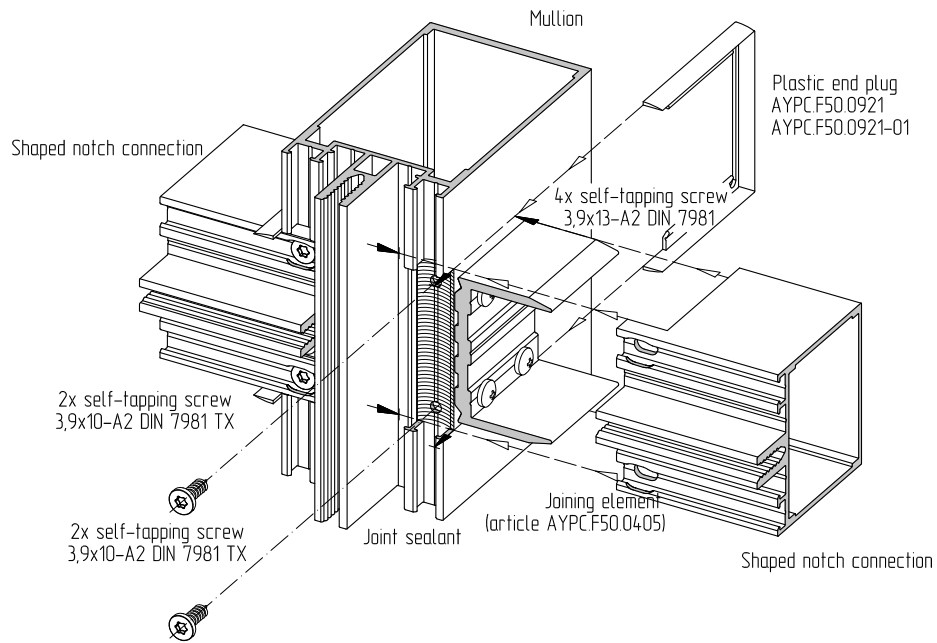

Shaped notch connection of mullions and transoms with help of joining element

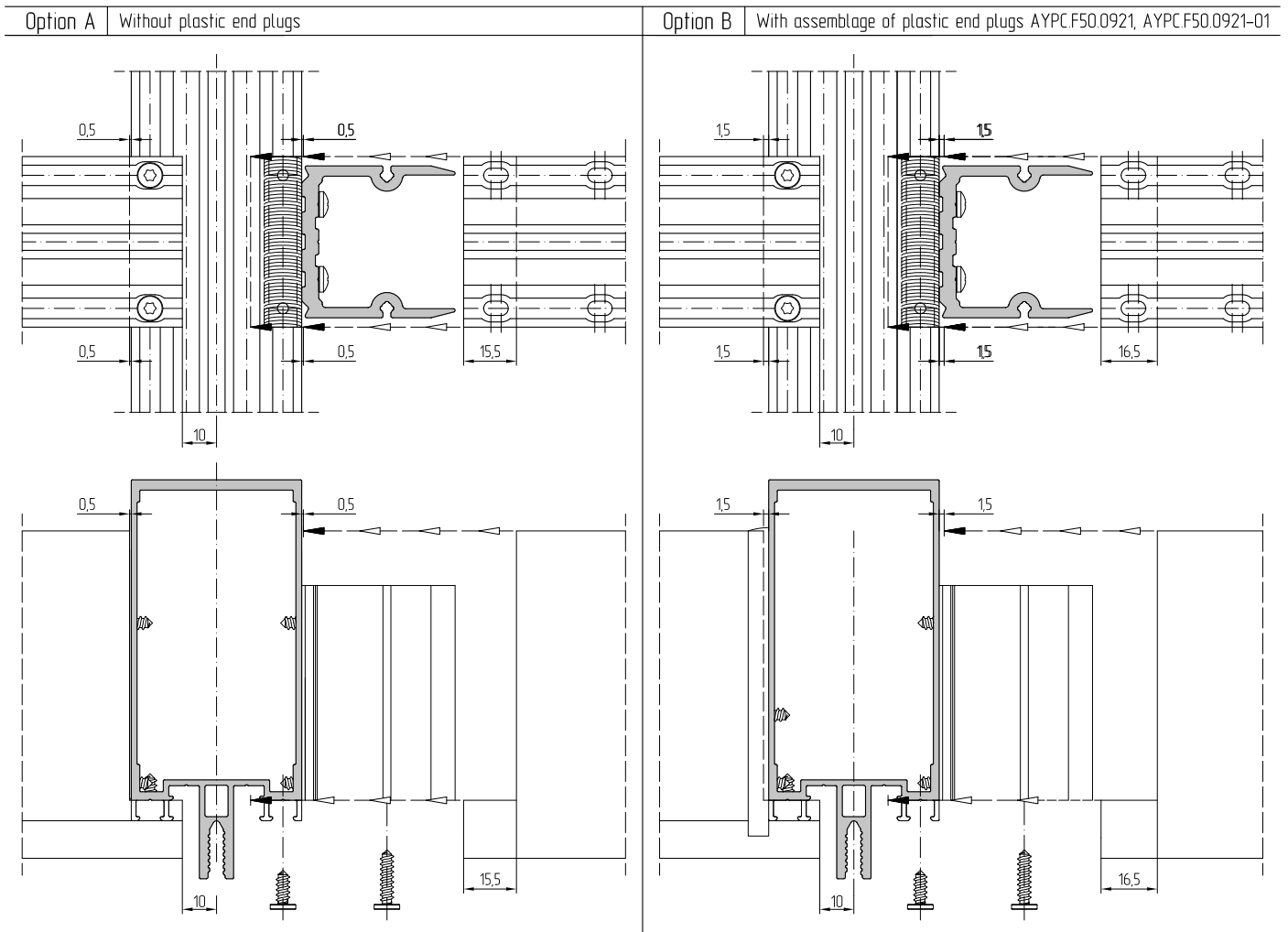
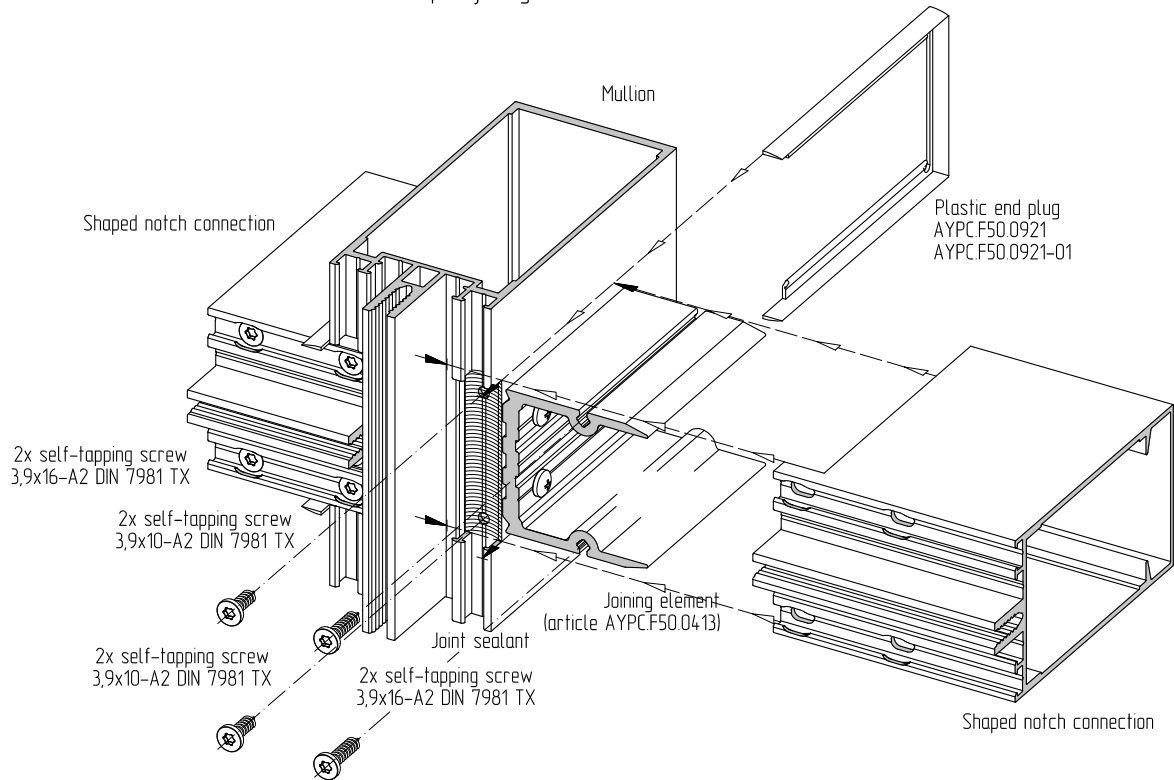

Shaped notch connection of mullions and transoms with help of joining element

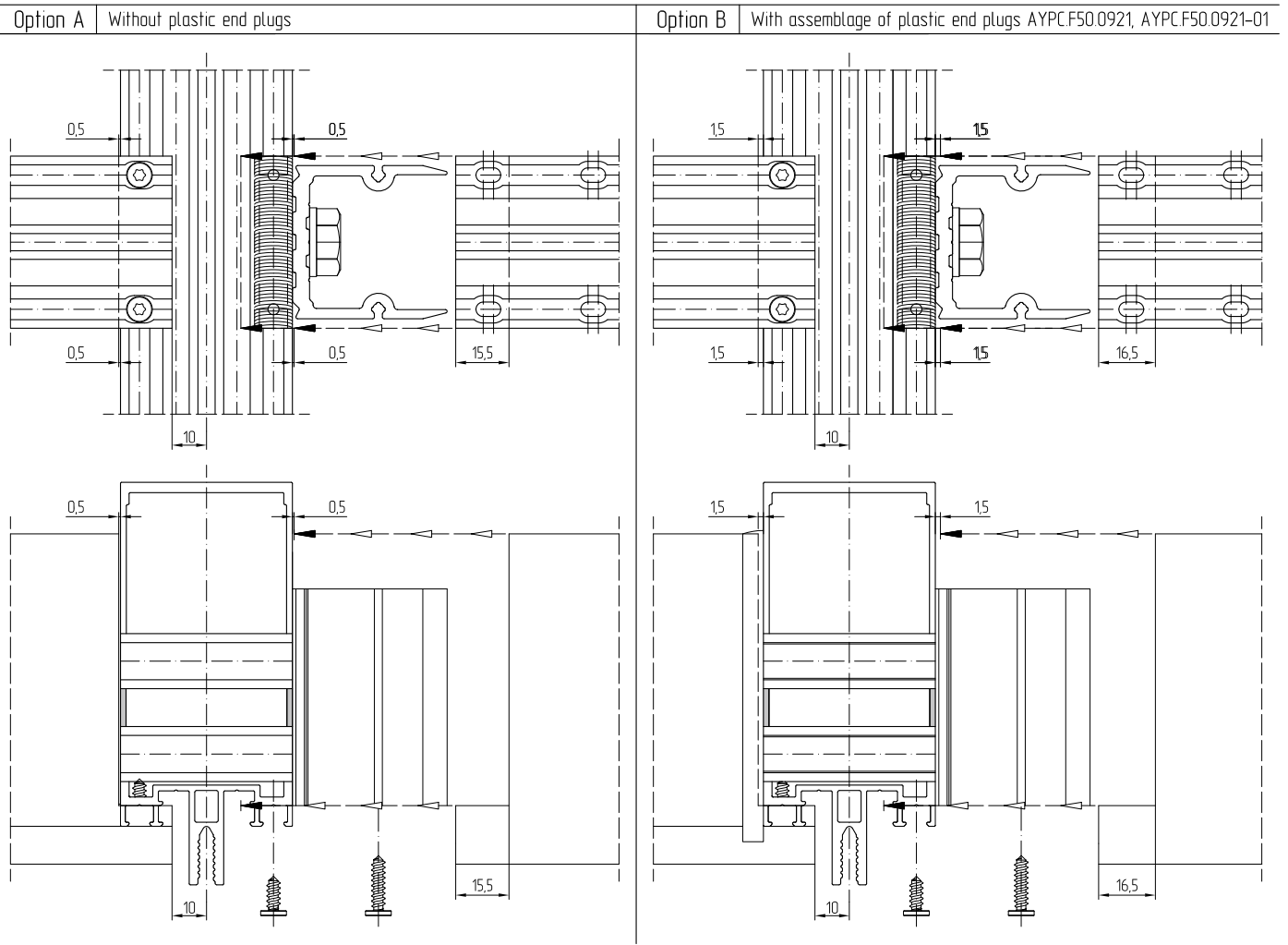
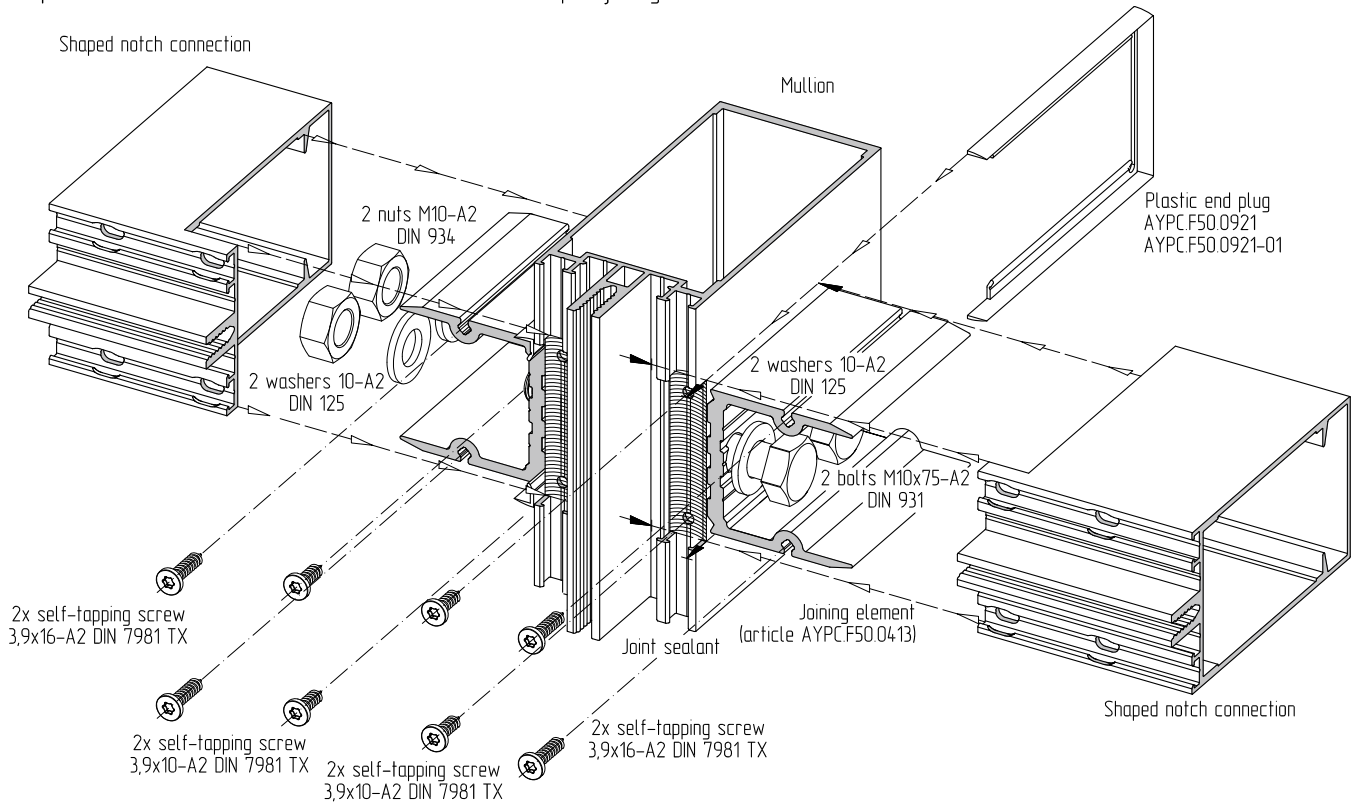

Shaped notch connection of mullions and transoms with help of joining element

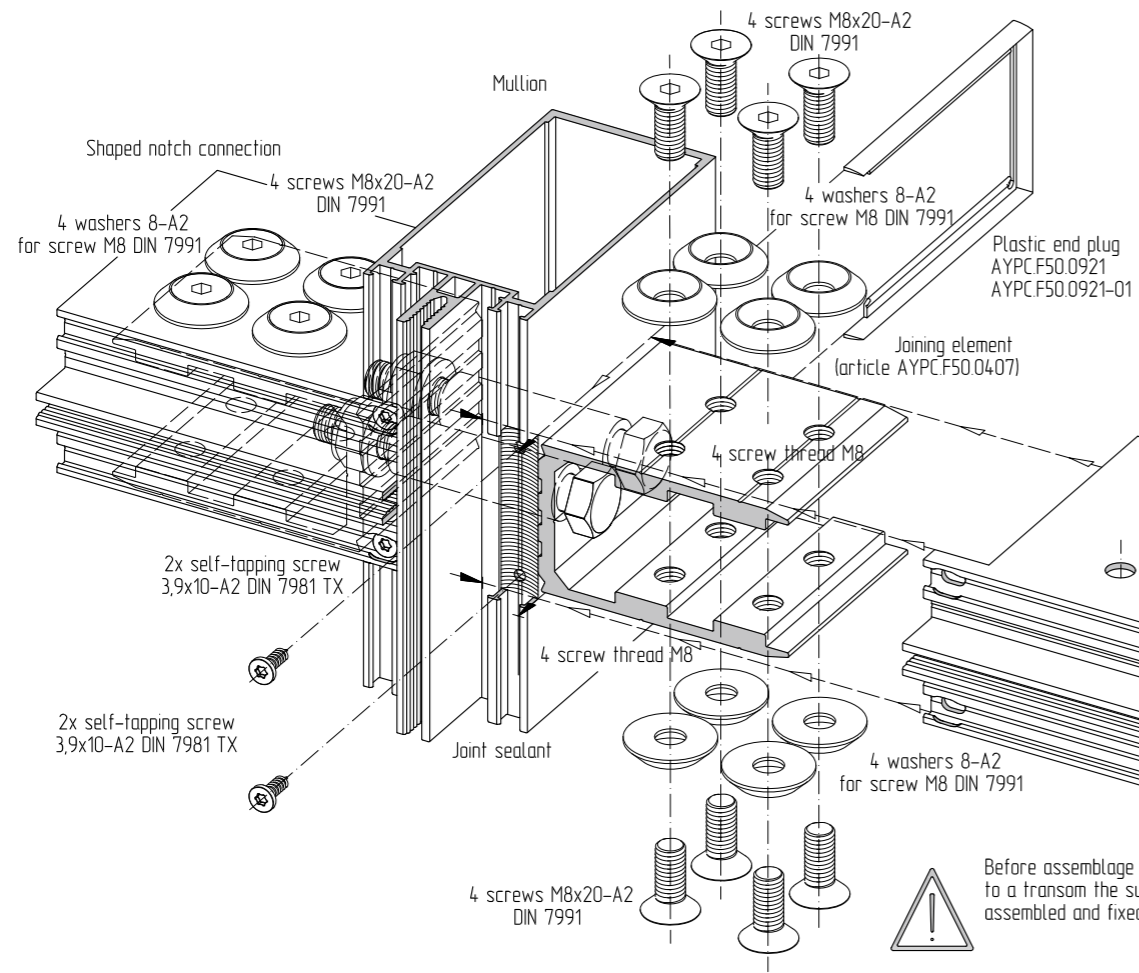

Glazing thickness, mm	Support plate	Support plate	Length screws L, mm
34-38	AYPC.F50.0948	AYPC.F50.0949	32 DIN 7981
40-44	AYPC.F50.0948-01	AYPC.F50.0949-01	35 ISO 4762
46-50	AYPC.F50.0948-02	AYPC.F50.0949-02	38 DIN 7981
52-56	AYPC.F50.0948-03	AYPC.F50.0949-03	45 DIN 7981

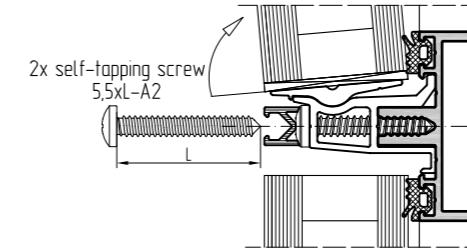
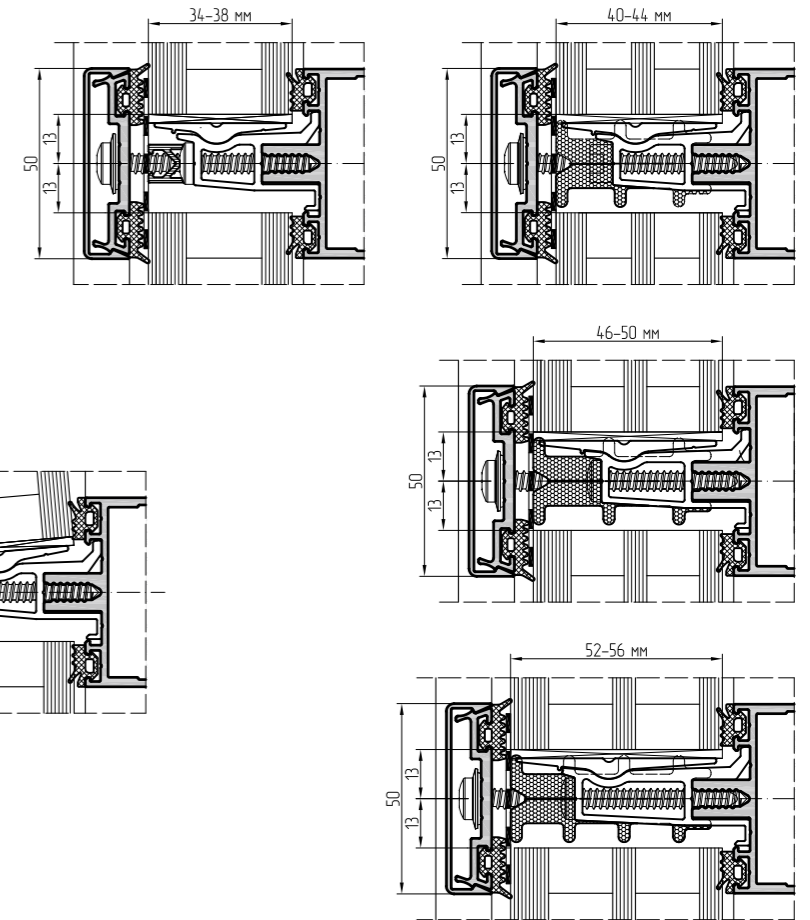

Aluminium support plate see the following table

Option A Without plastic end plugs

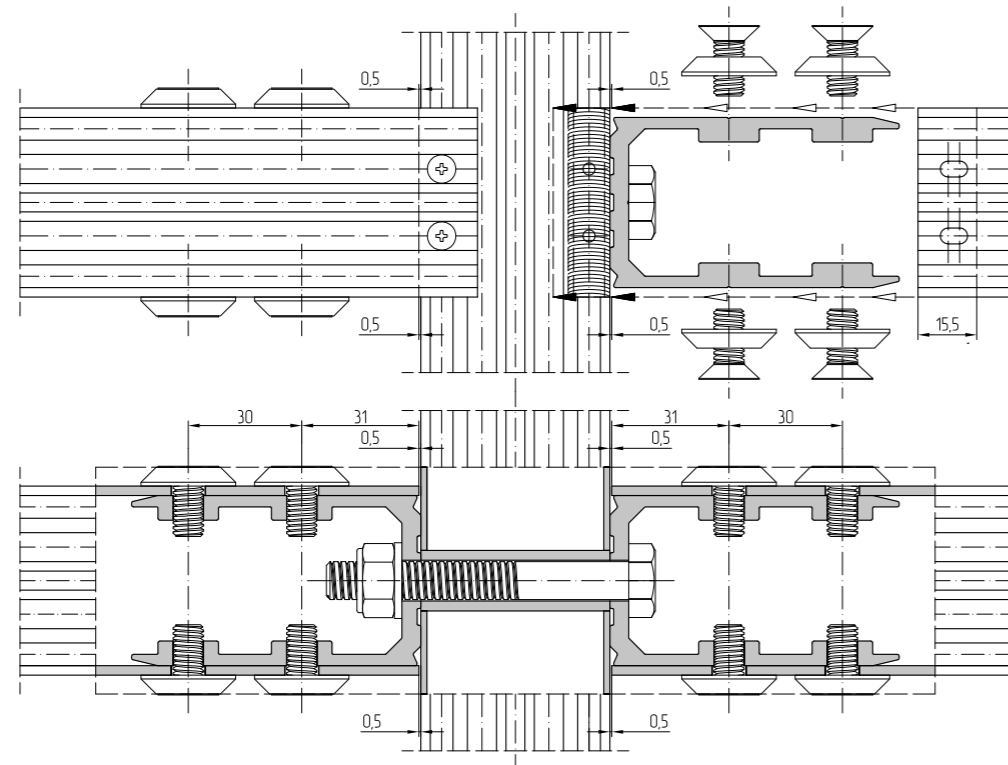

Option B With assemblage of plastic end plugs AYP.C.F50.0921, AYP.C.F50.0921-01

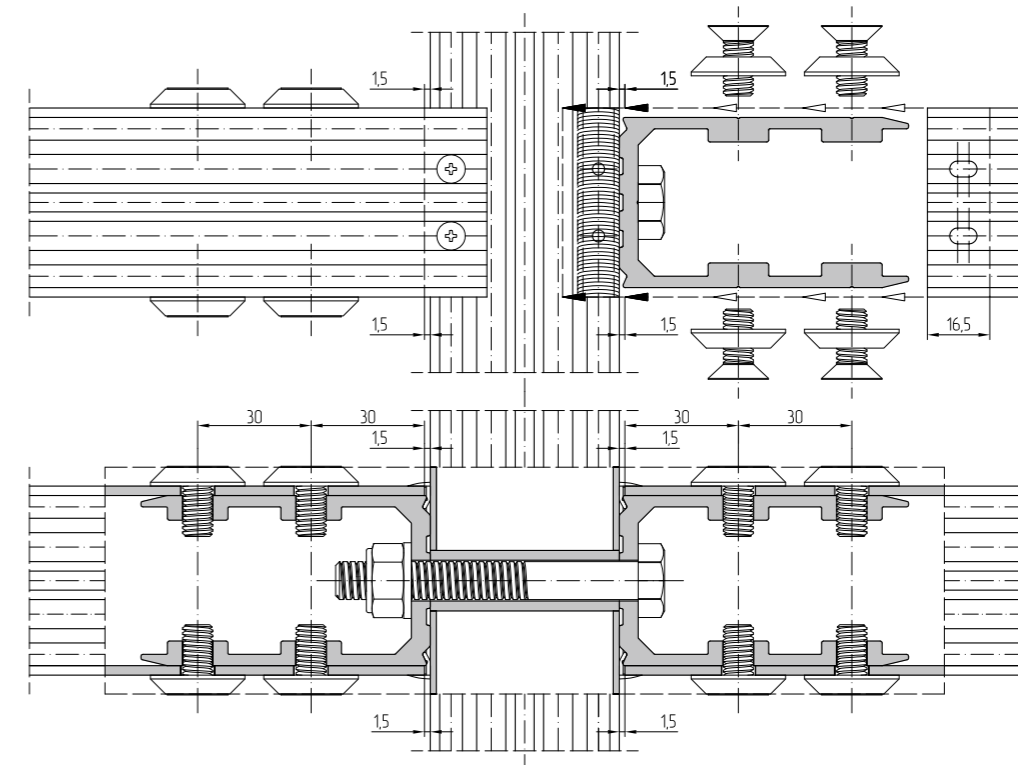



Shaped notch connection of mullions and transoms with help of joining element

Glazing thickness, mm	Support plate	Support plate	Length screws L, mm
34-38	AYPC.F50.0948	AYPC.F50.0949	32 DIN 7981
40-44	AYPC.F50.0948-01	AYPC.F50.0949-01	35 ISO 4762
46-50	AYPC.F50.0948-02	AYPC.F50.0949-02	38 DIN 7981
52-56	AYPC.F50.0948-03	AYPC.F50.0949-03	45 DIN 7981

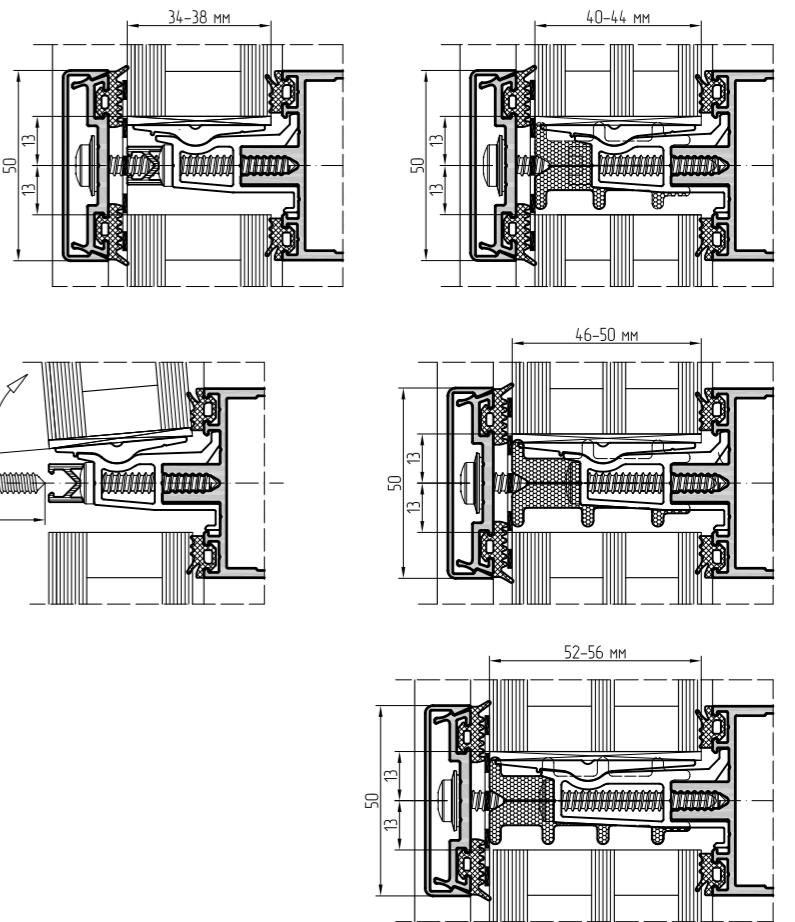
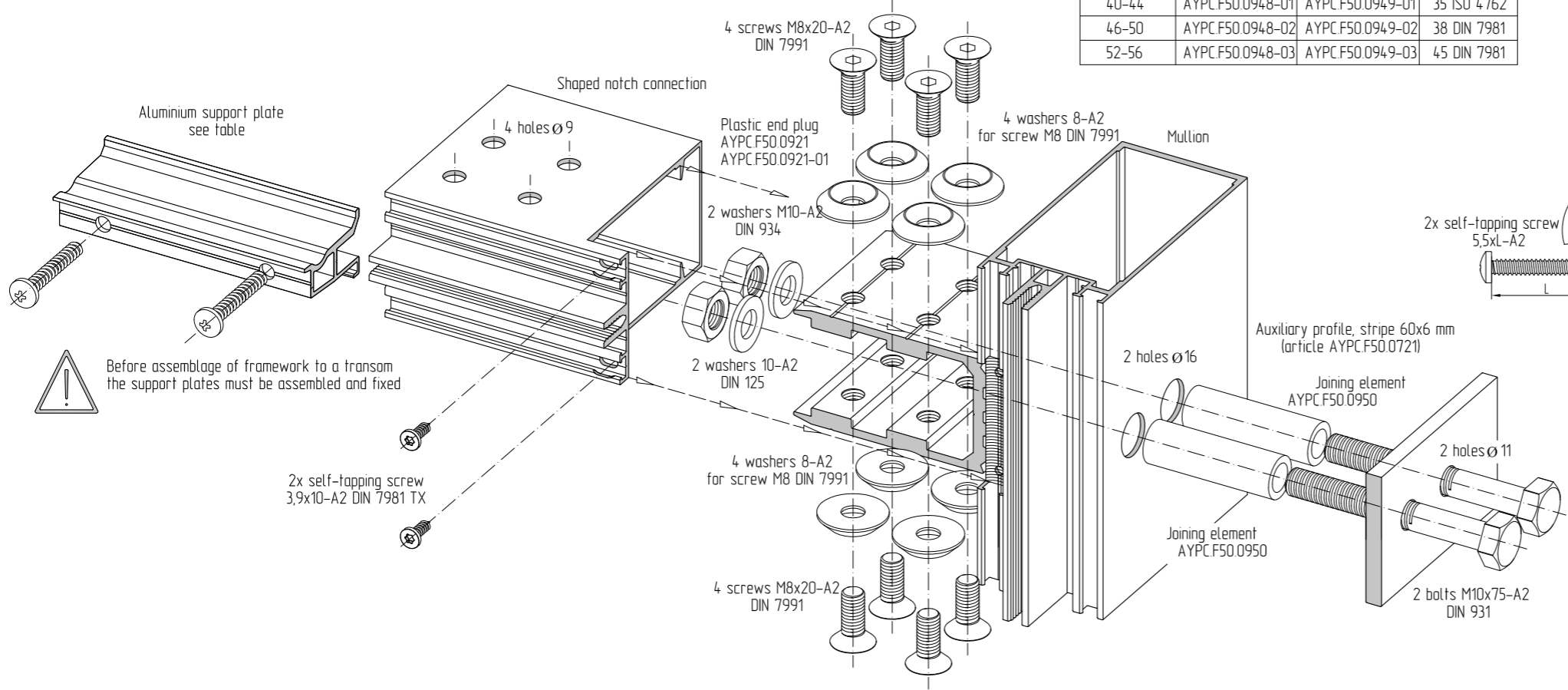

Option A Without plastic end plugs

Option B With assemblage of plastic end plugs AYPC.F50.0921, AYPC.F50.0921-01

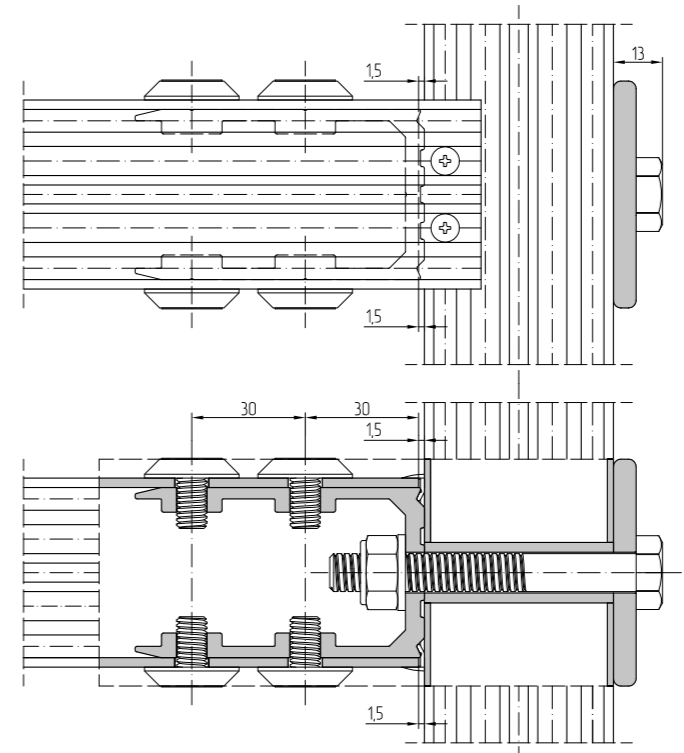
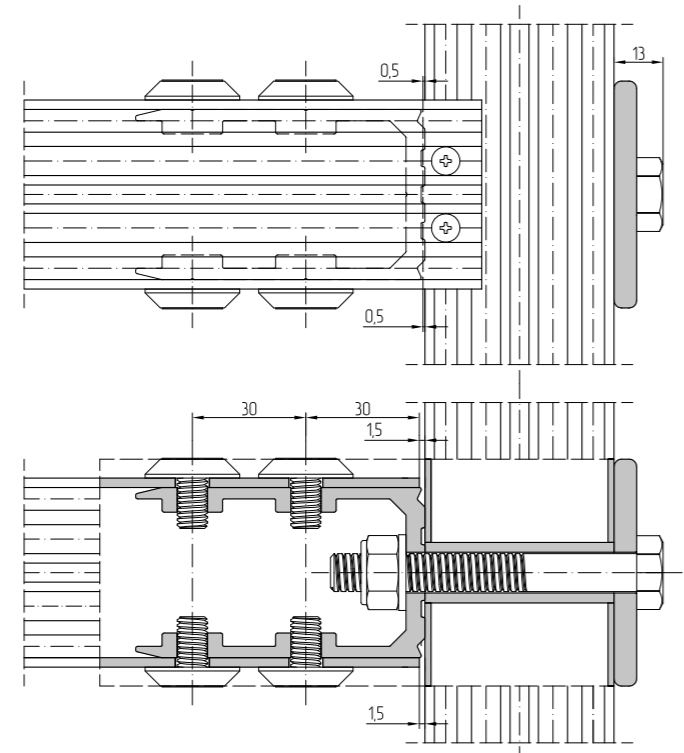



Shaped notch connection of mullions and transoms with help of joining element

Glazing thickness, mm	Support plate	Support plate	Length screws L, mm
34-38	AYPC.F50.0948	AYPC.F50.0949	32 DIN 7981
40-44	AYPC.F50.0948-01	AYPC.F50.0949-01	35 ISO 4762
46-50	AYPC.F50.0948-02	AYPC.F50.0949-02	38 DIN 7981
52-56	AYPC.F50.0948-03	AYPC.F50.0949-03	45 DIN 7981

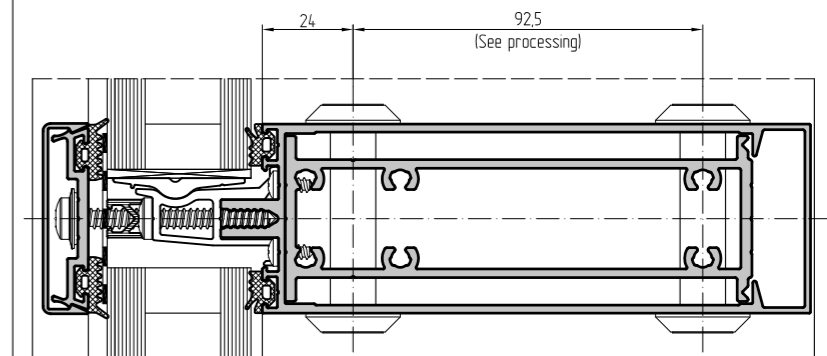
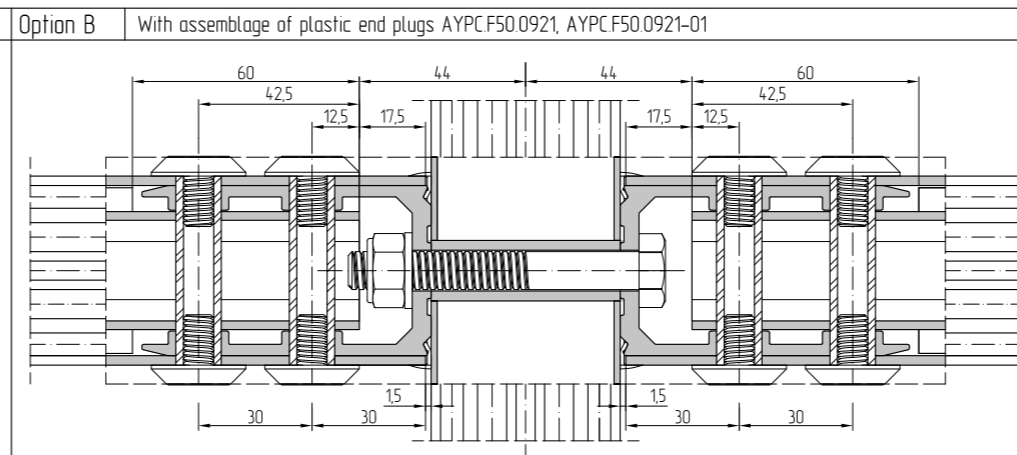
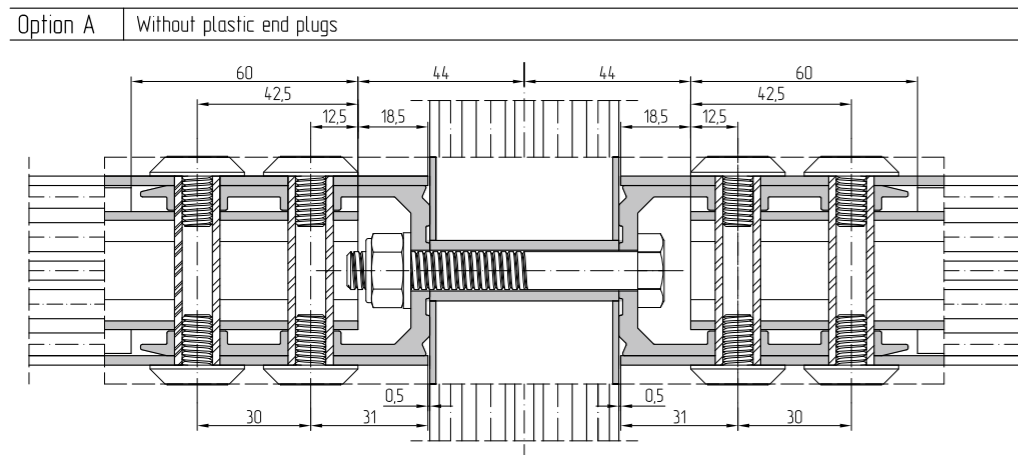
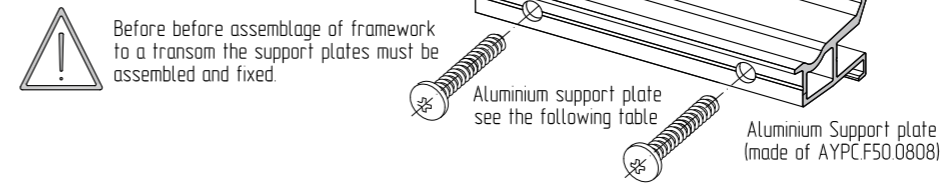
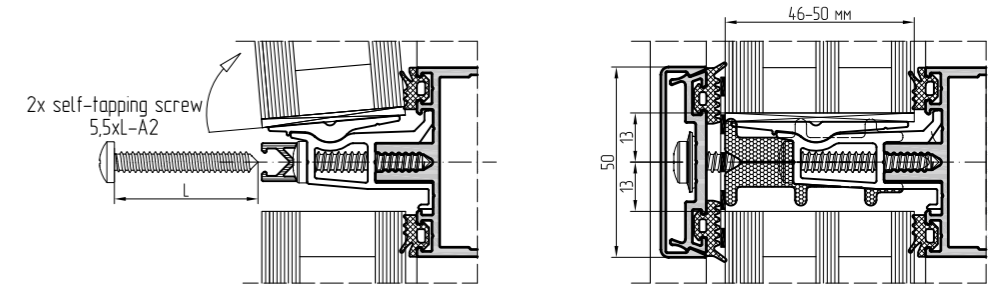
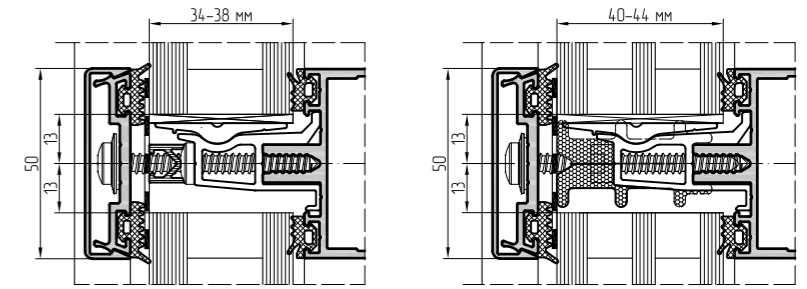
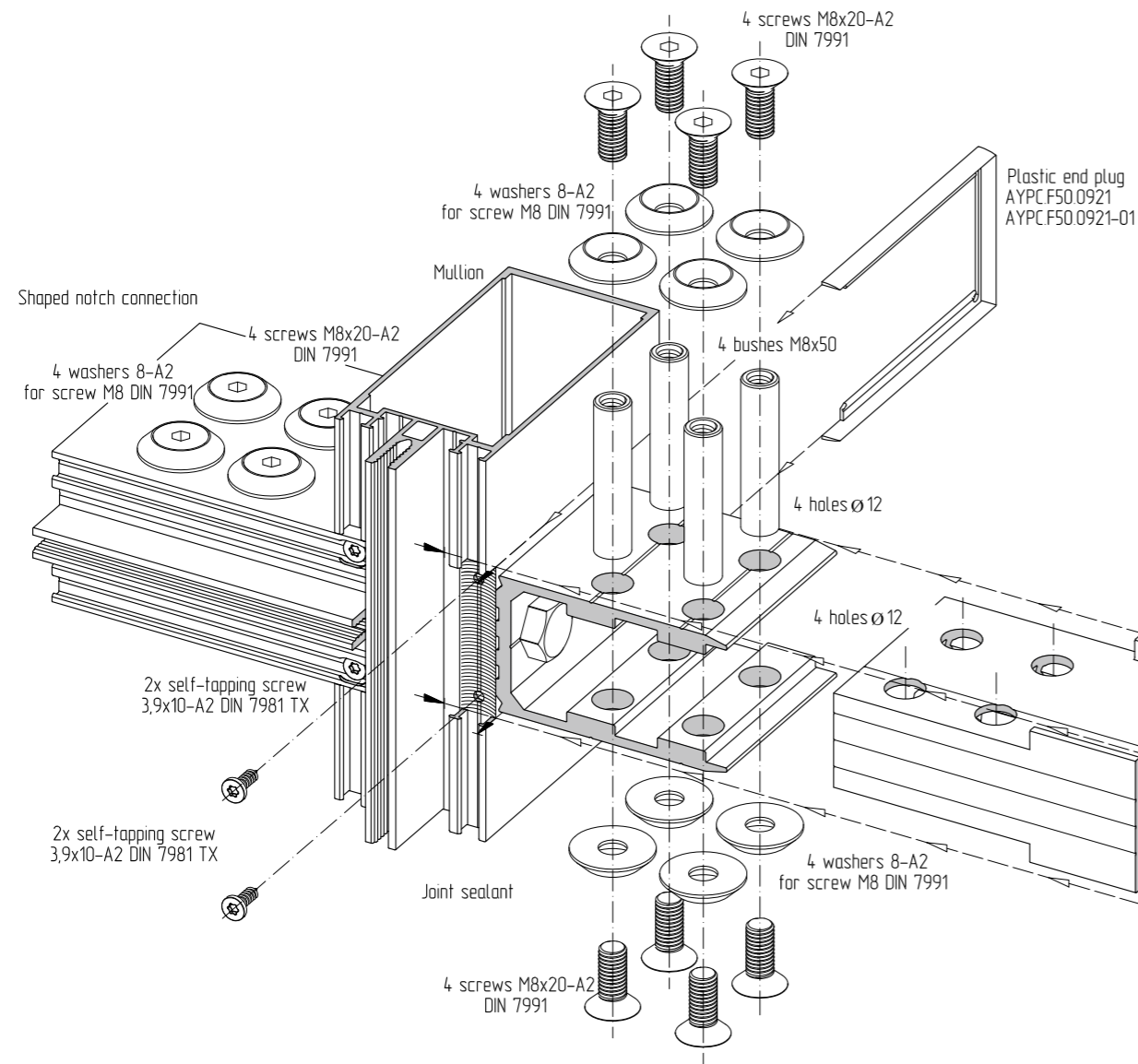



Shaped notch connection of mullions and transoms with help of slide and a joining element

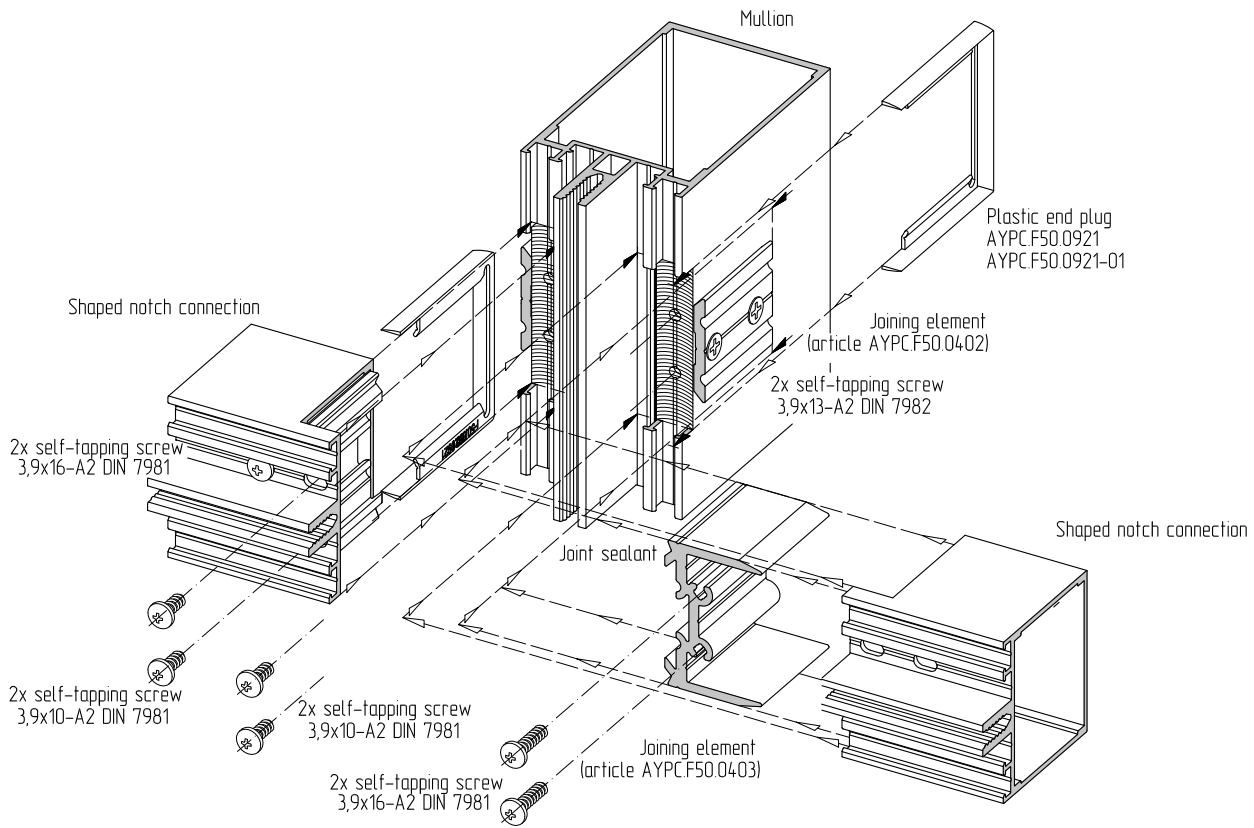

With assemblage of plastic end plugs AYPC.F50.0921, AYPC.F50.0921-01

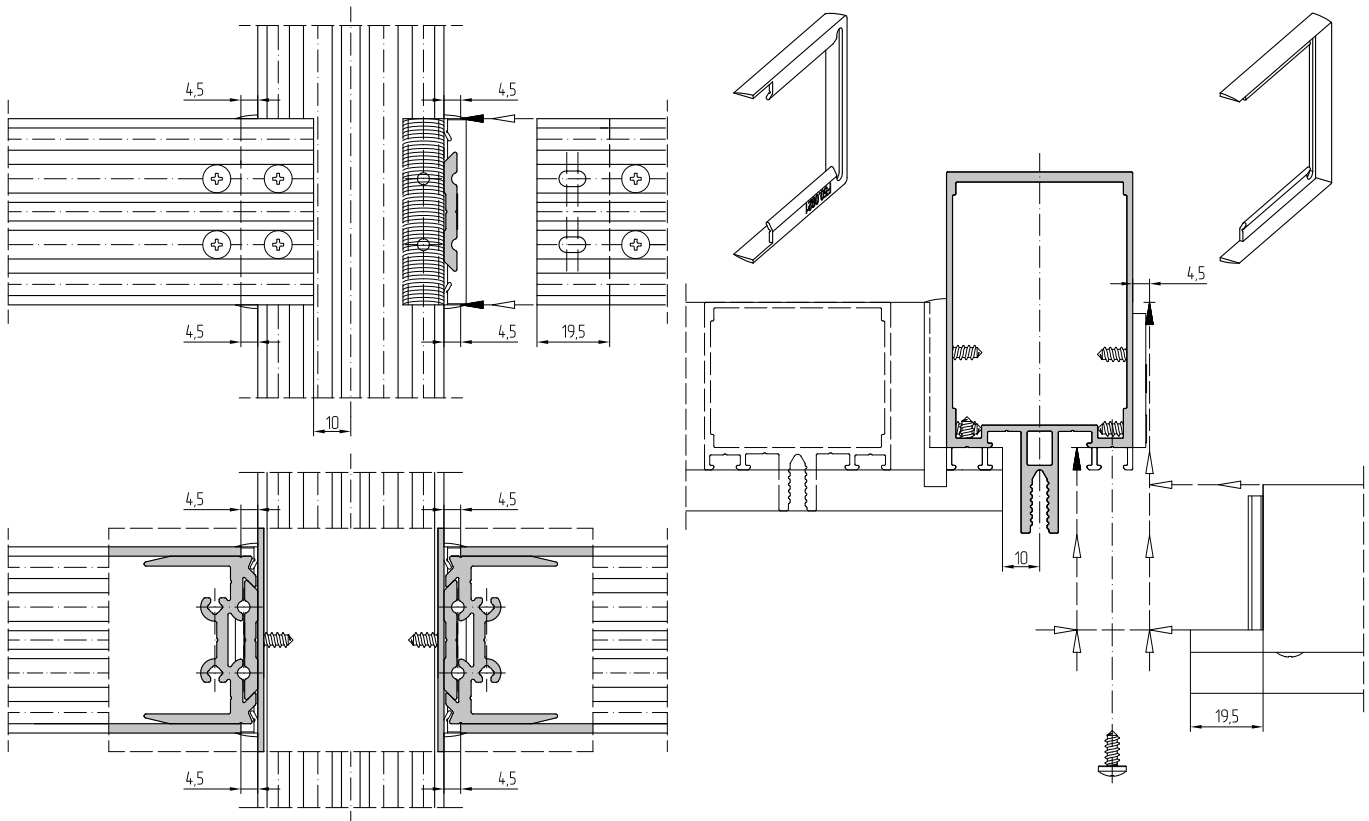

Shaped notch connection of mullions and inclined transoms without joining element

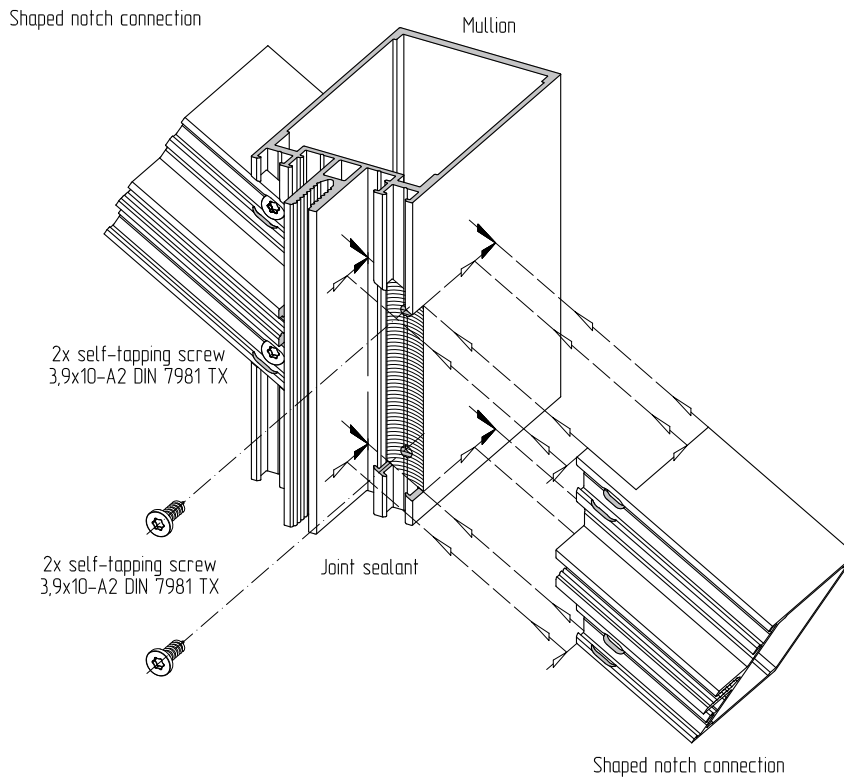

Without plastic end plugs

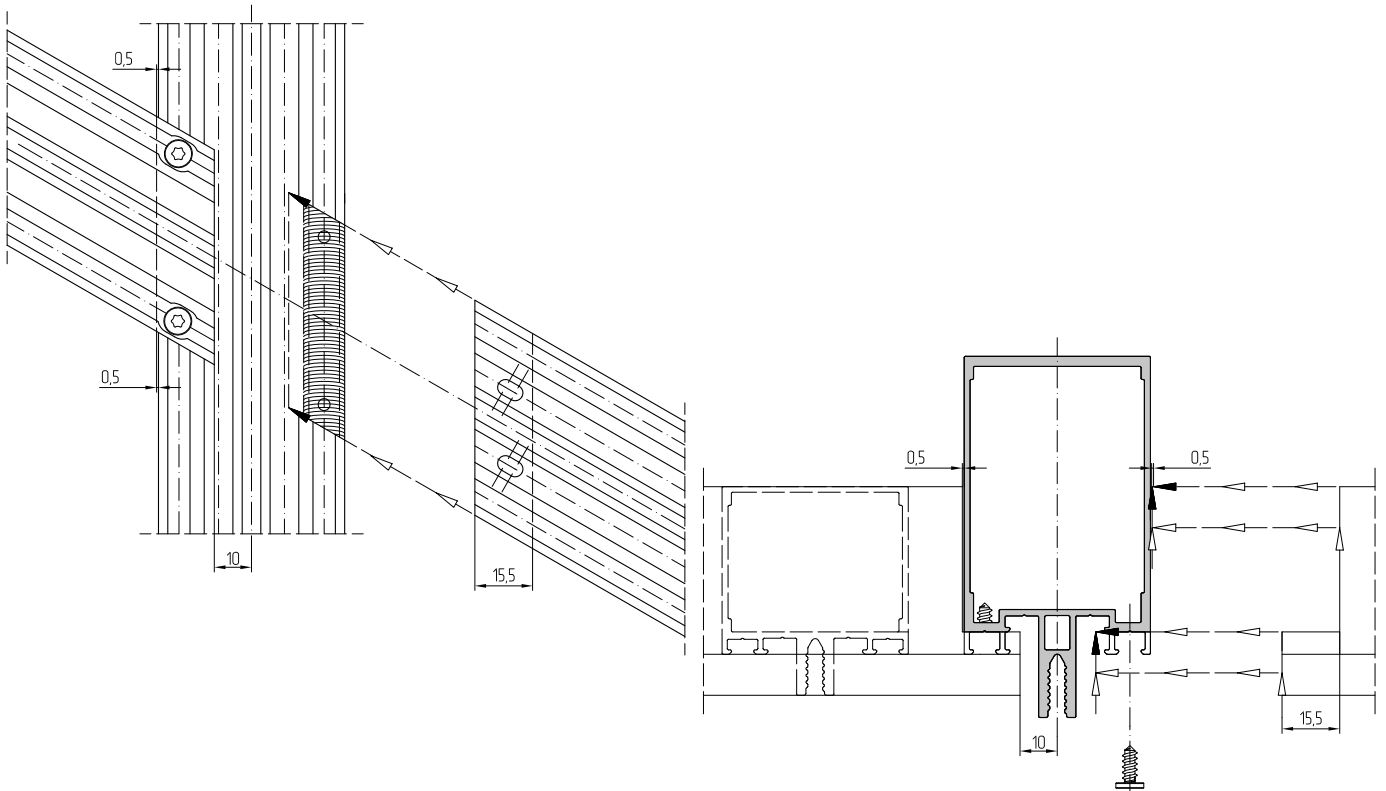

Shaped notch connection of mullions and inclined transoms with help of joining element

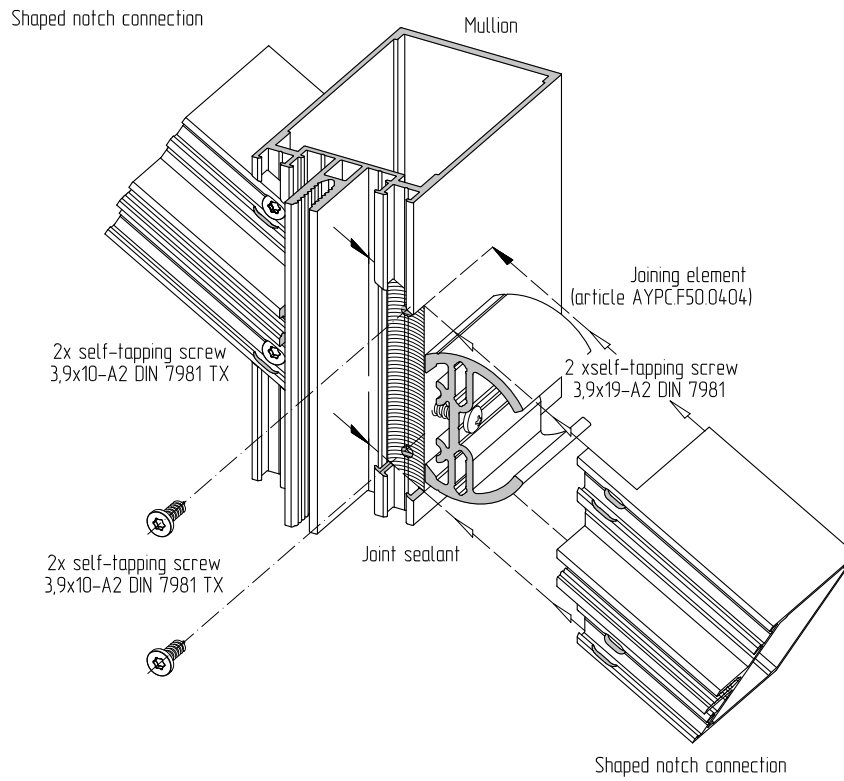

Without plastic end plugs

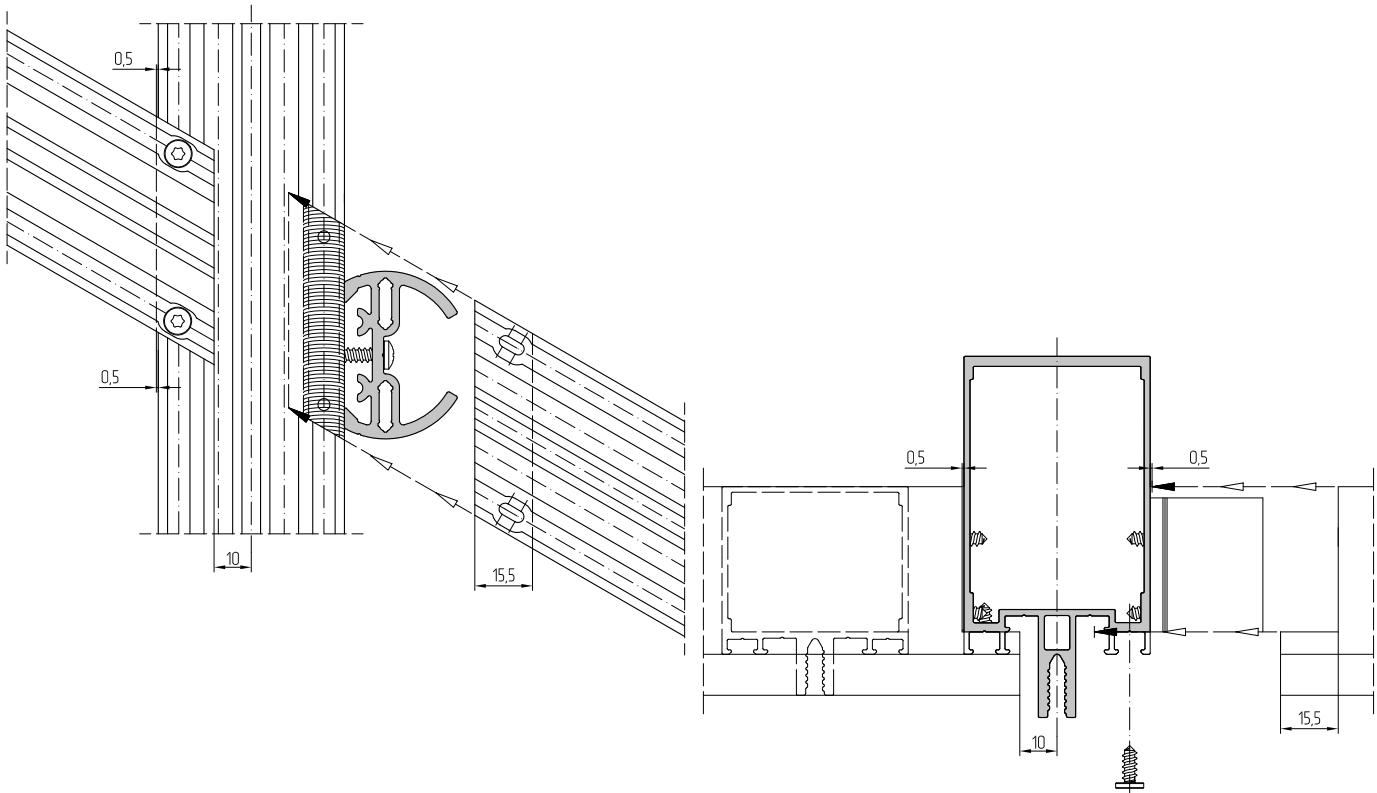

Notch connection of Mullions and transoms with help of auxiliary profiles.

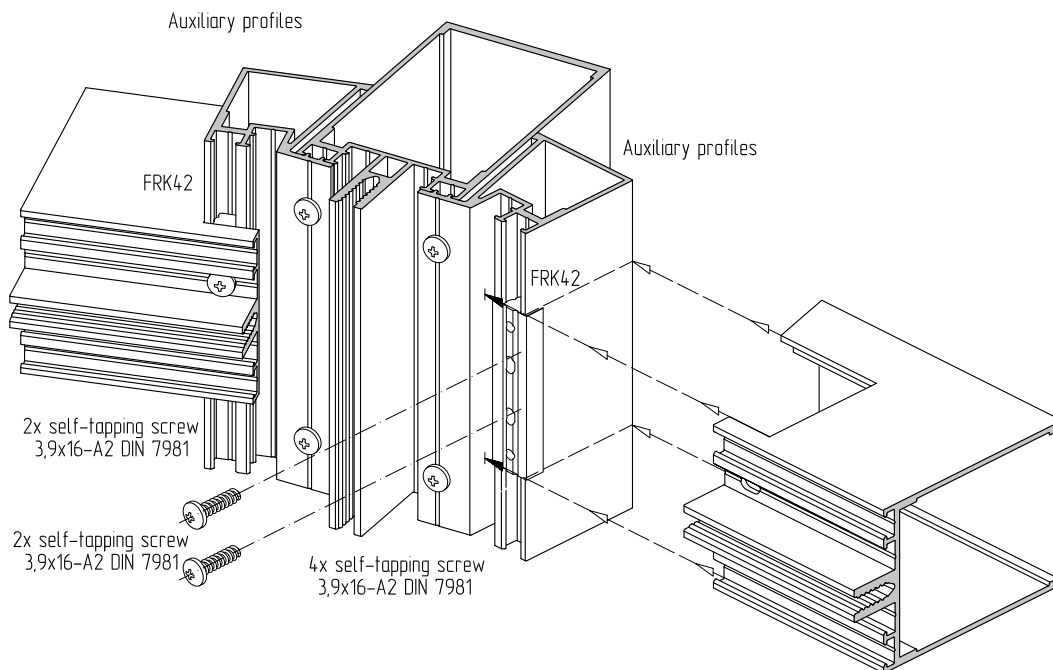
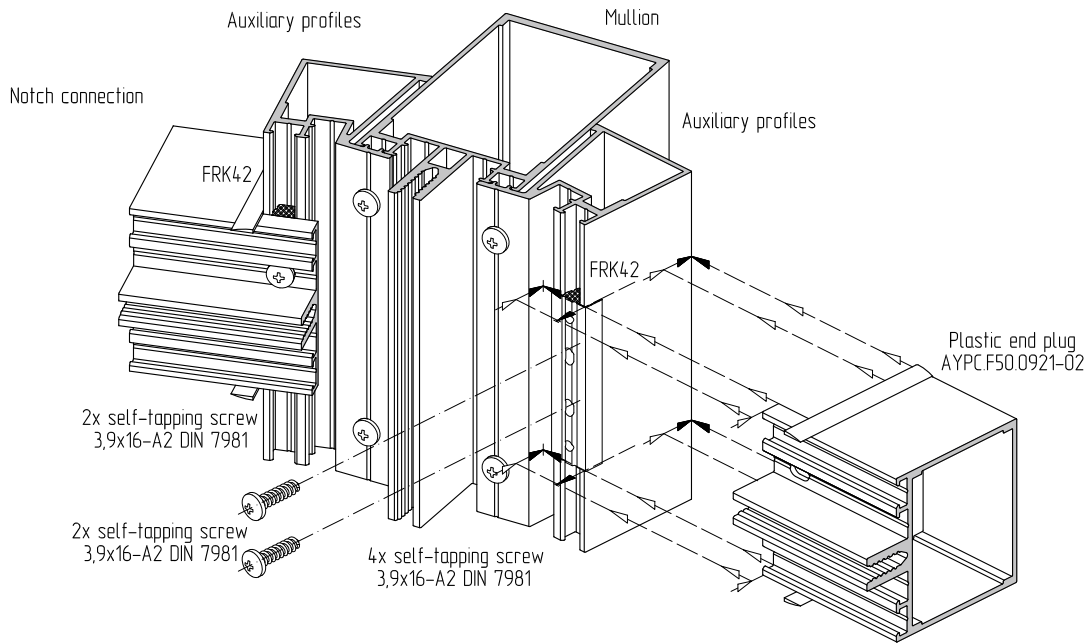

Vertical connection of mounting mullions

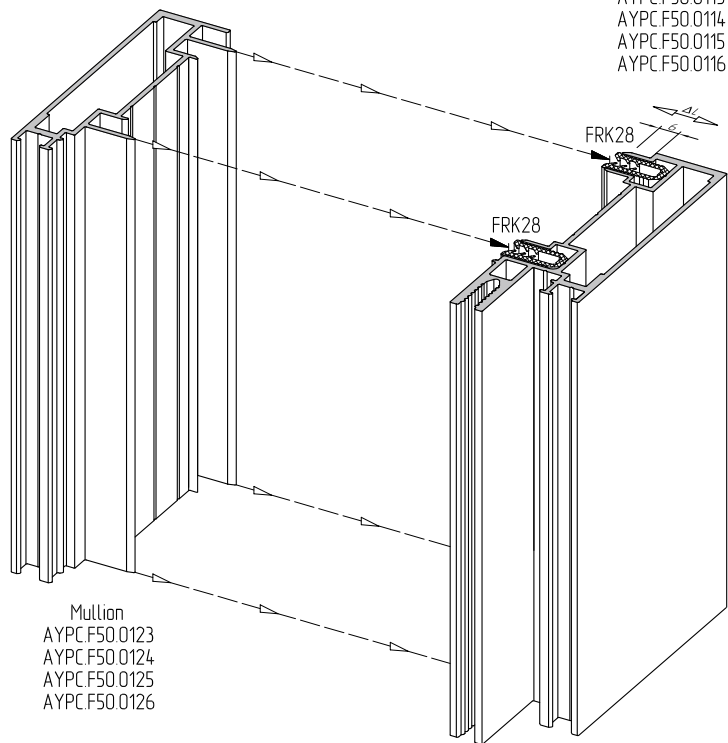
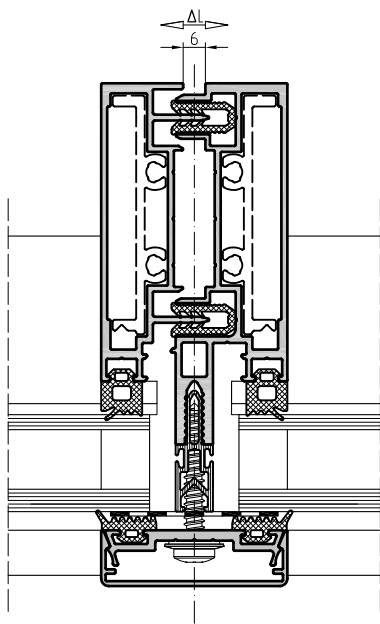

Vertical connection of mounting mullions at angle

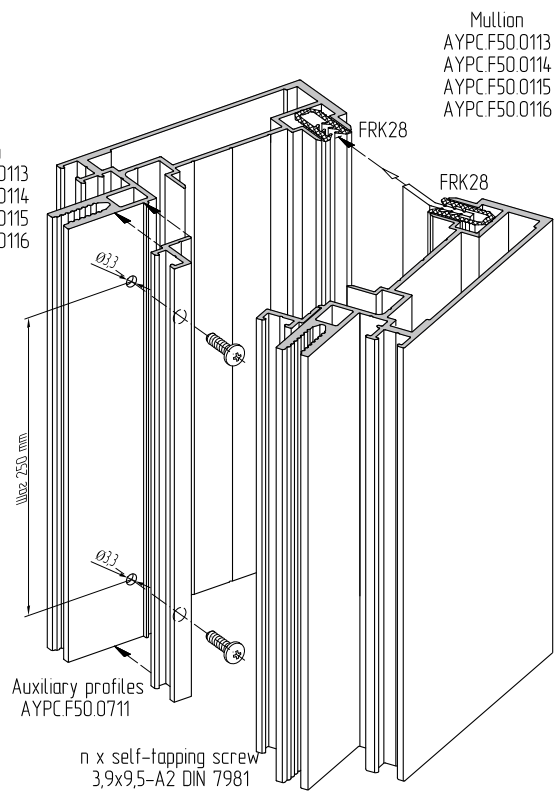
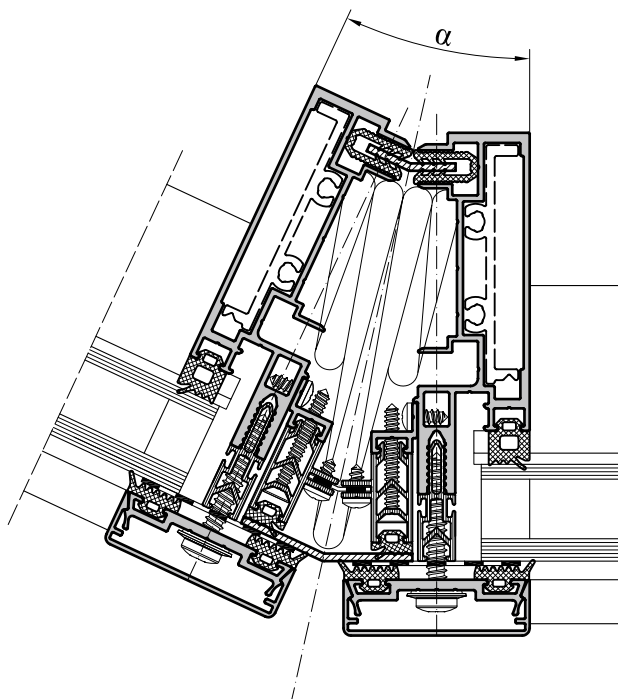

Vertical direct connection of mullions

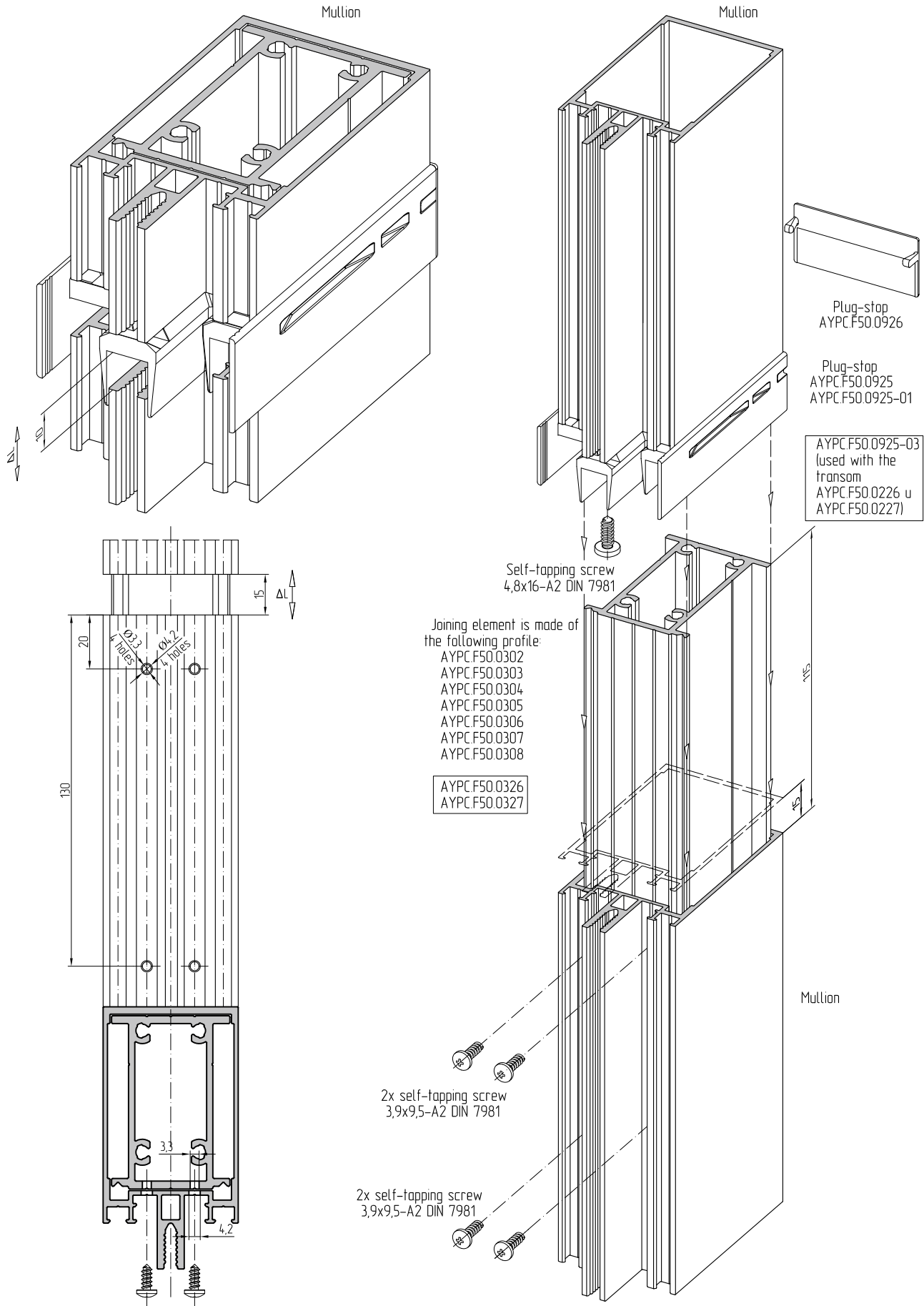



Vertical direct connection of mullions

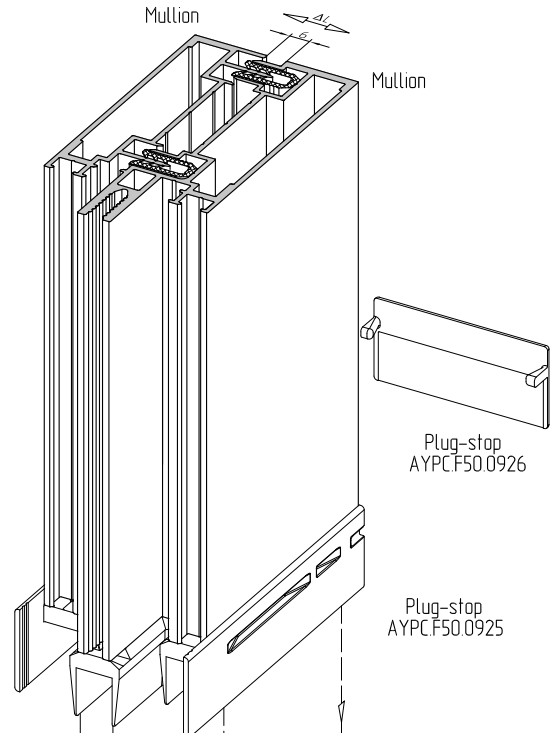
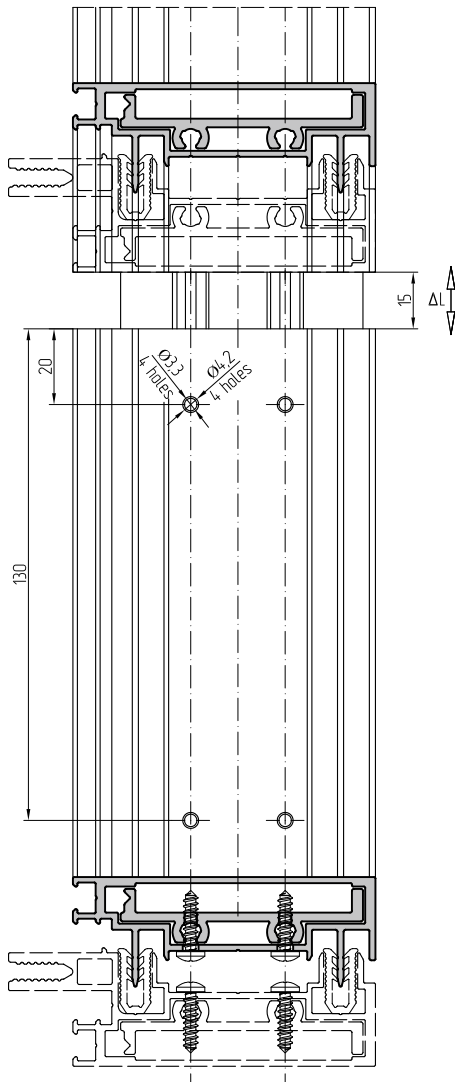
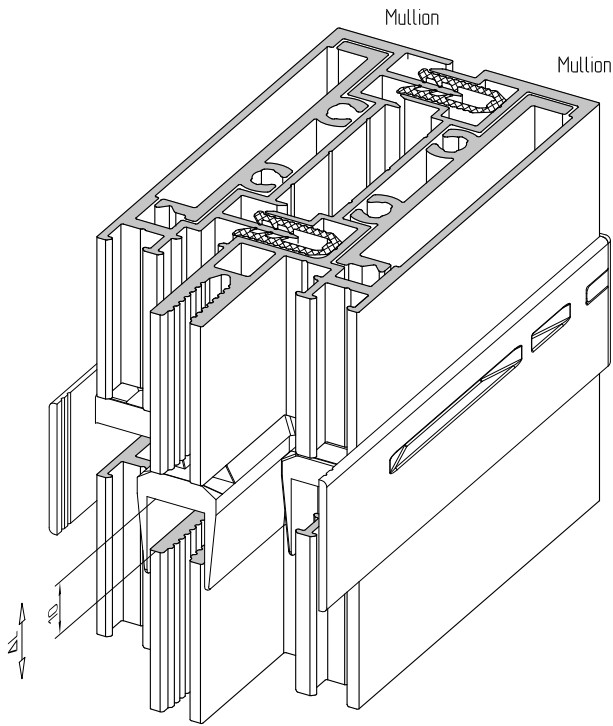

Self-tapping screw  
4,8x16-A2 DIN 7981

Joining element is made of  
the following profile:  
AYPC.F50.0313  
AYPC.F50.0314  
AYPC.F50.0315  
AYPC.F50.0316

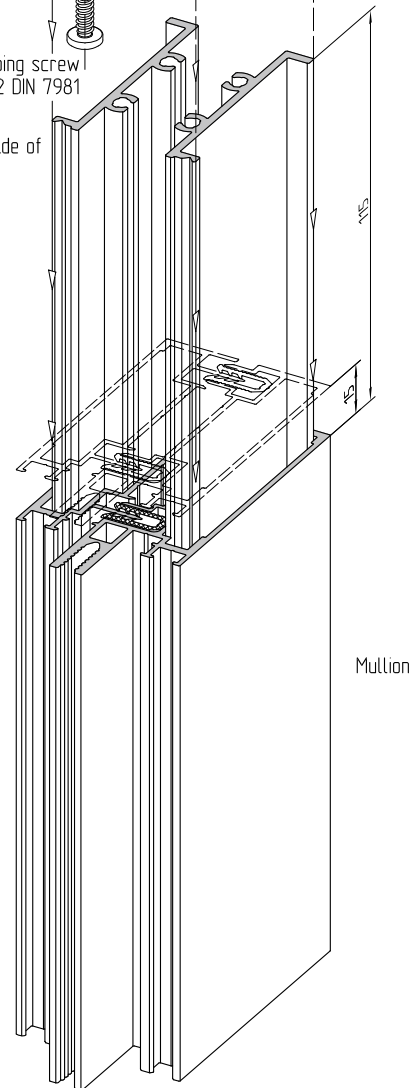

Vertical direct connection of mullions, Clamp bar and decorative cover cap.

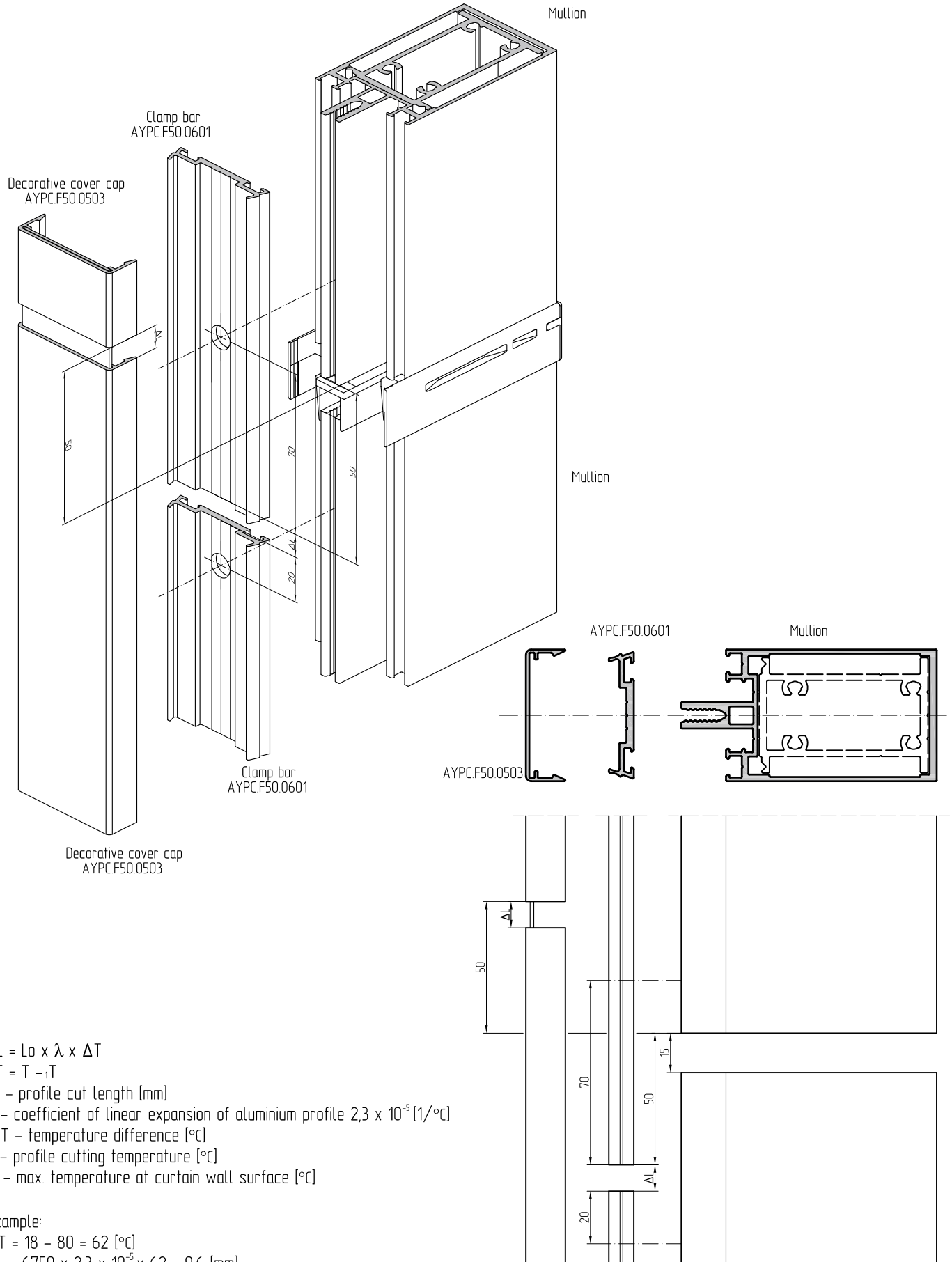

$\Delta L = L_0 \times \lambda \times \Delta T$   
 $\Delta T = T - T_1$   
 $L_0$  - profile cut length [mm]  
 $\lambda$  - coefficient of linear expansion of aluminium profile  $2,3 \times 10^{-5}$  [1/°C]  
 $\Delta T$  - temperature difference [°C]  
 $T$  - profile cutting temperature [°C]  
 $T_1$  - max. temperature at curtain wall surface [°C]

Example:  
 $\Delta T = 18 - 80 = 62$  [°C]  
 $\Delta L = 6750 \times 2,3 \times 10^{-5} \times 62 = 9,6$  [mm]

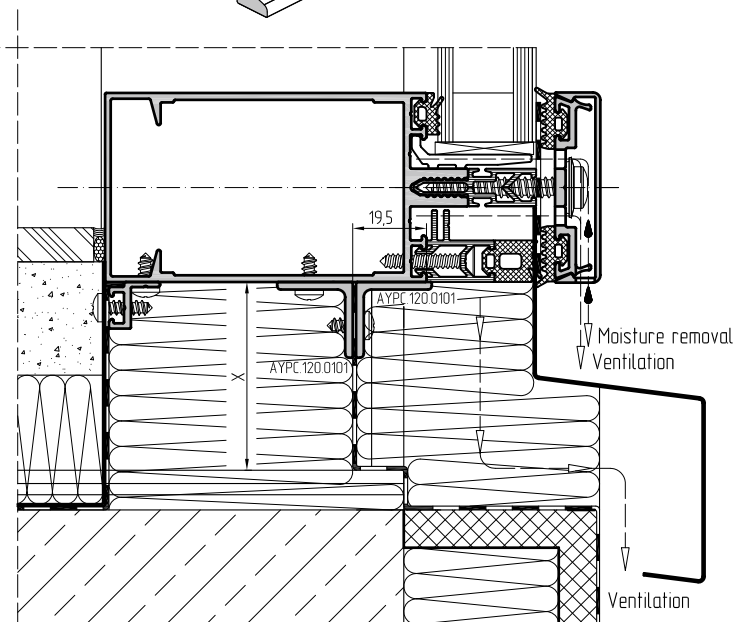
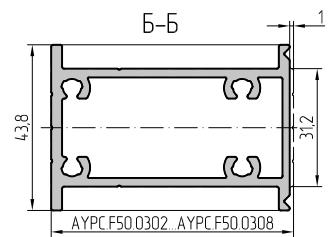
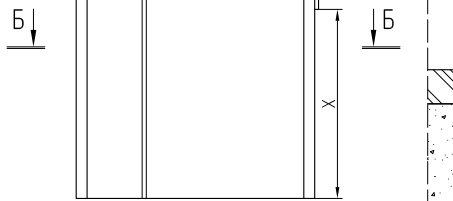
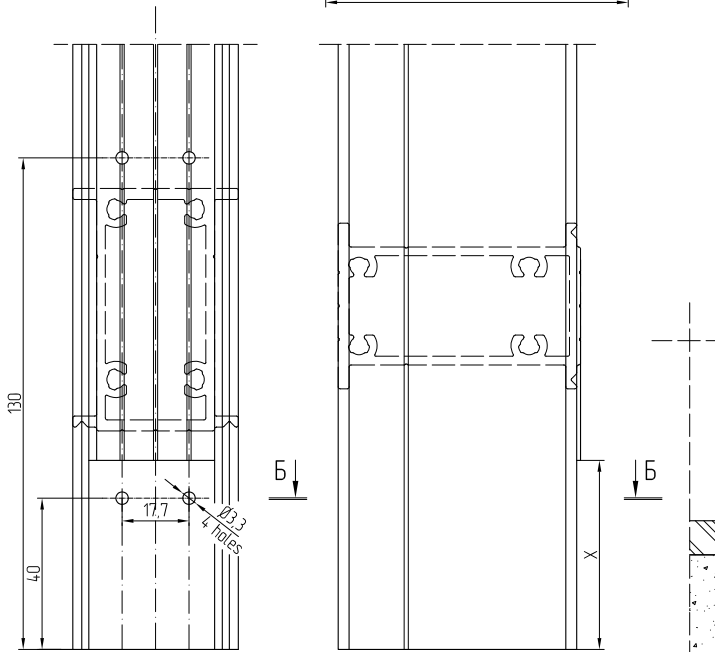
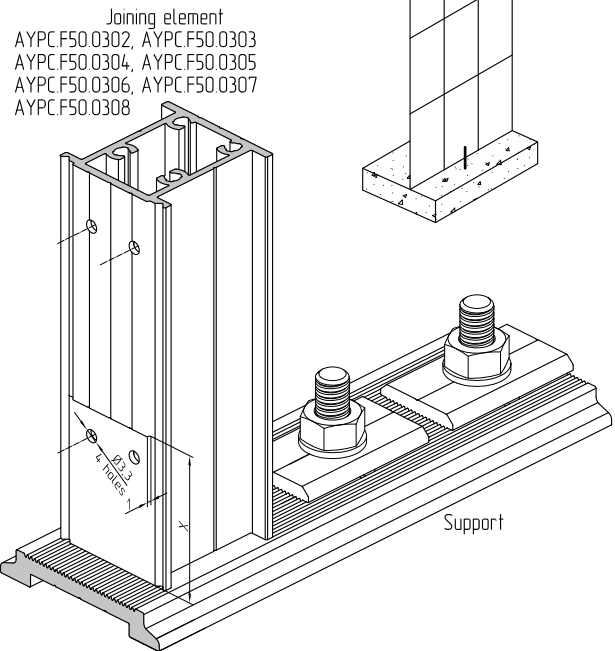
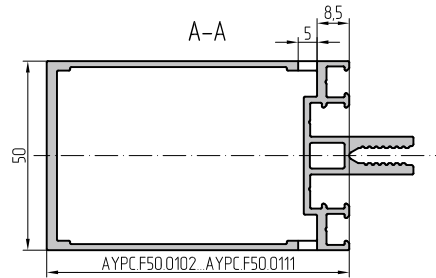
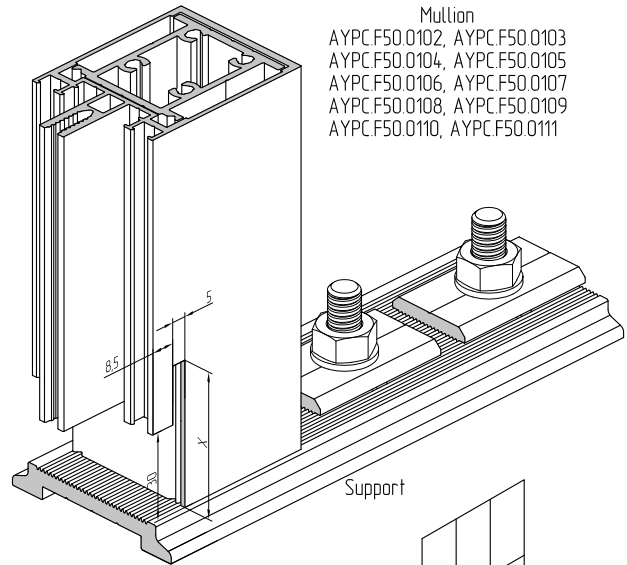
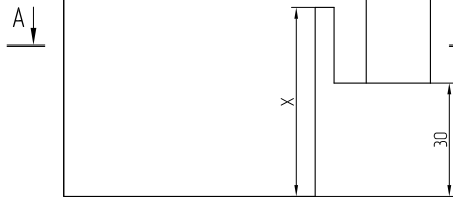
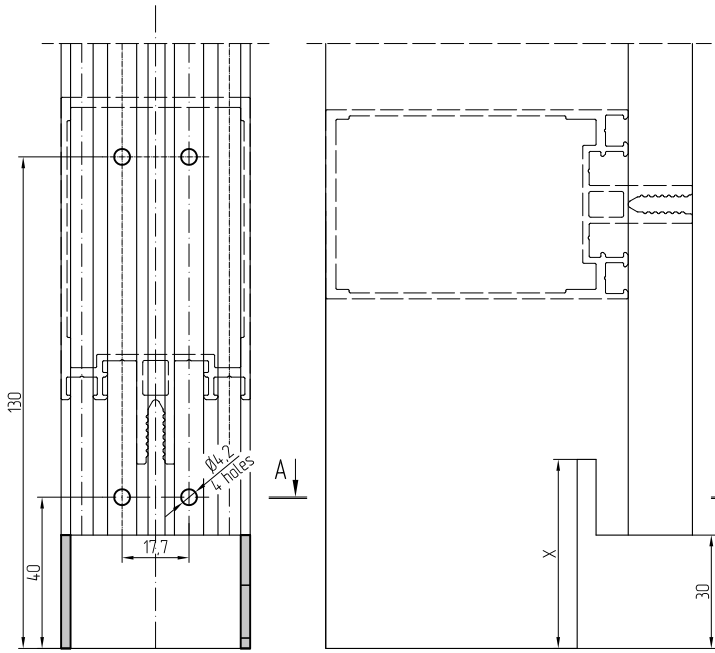

Curved connection of mullions

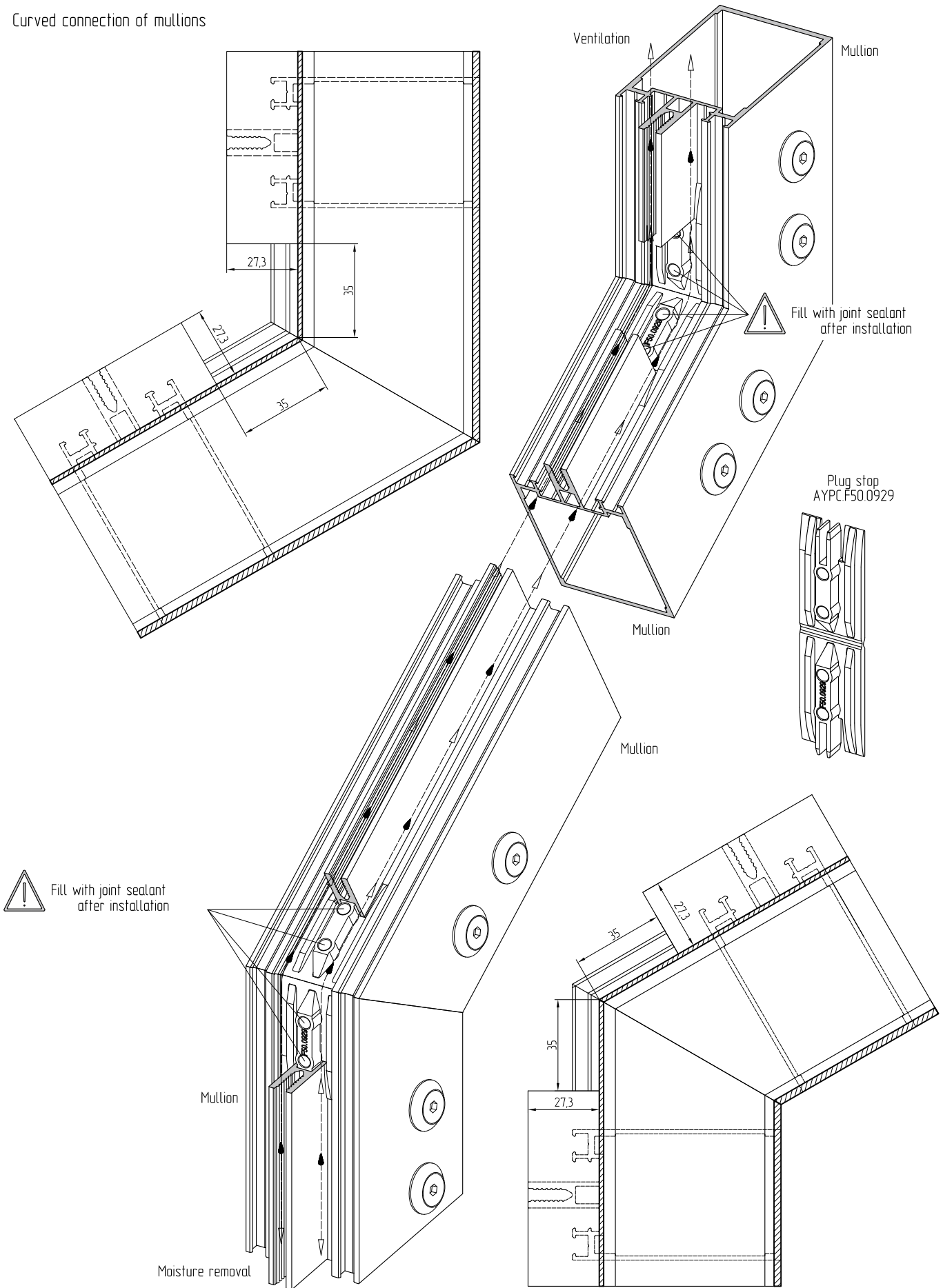

! Fill with joint sealant after installation

Mullions connection at an angle

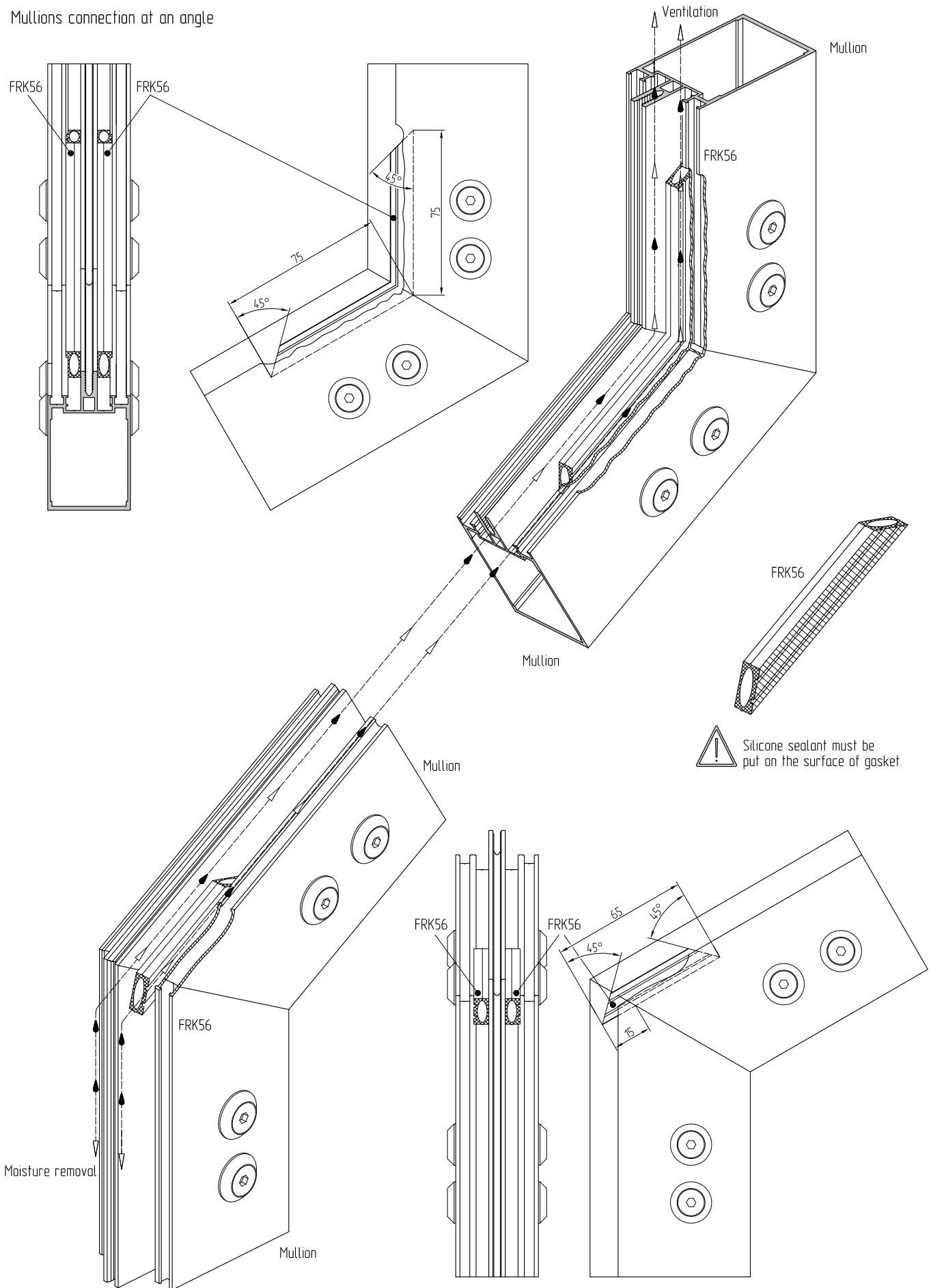





Inclined fixation of mullions

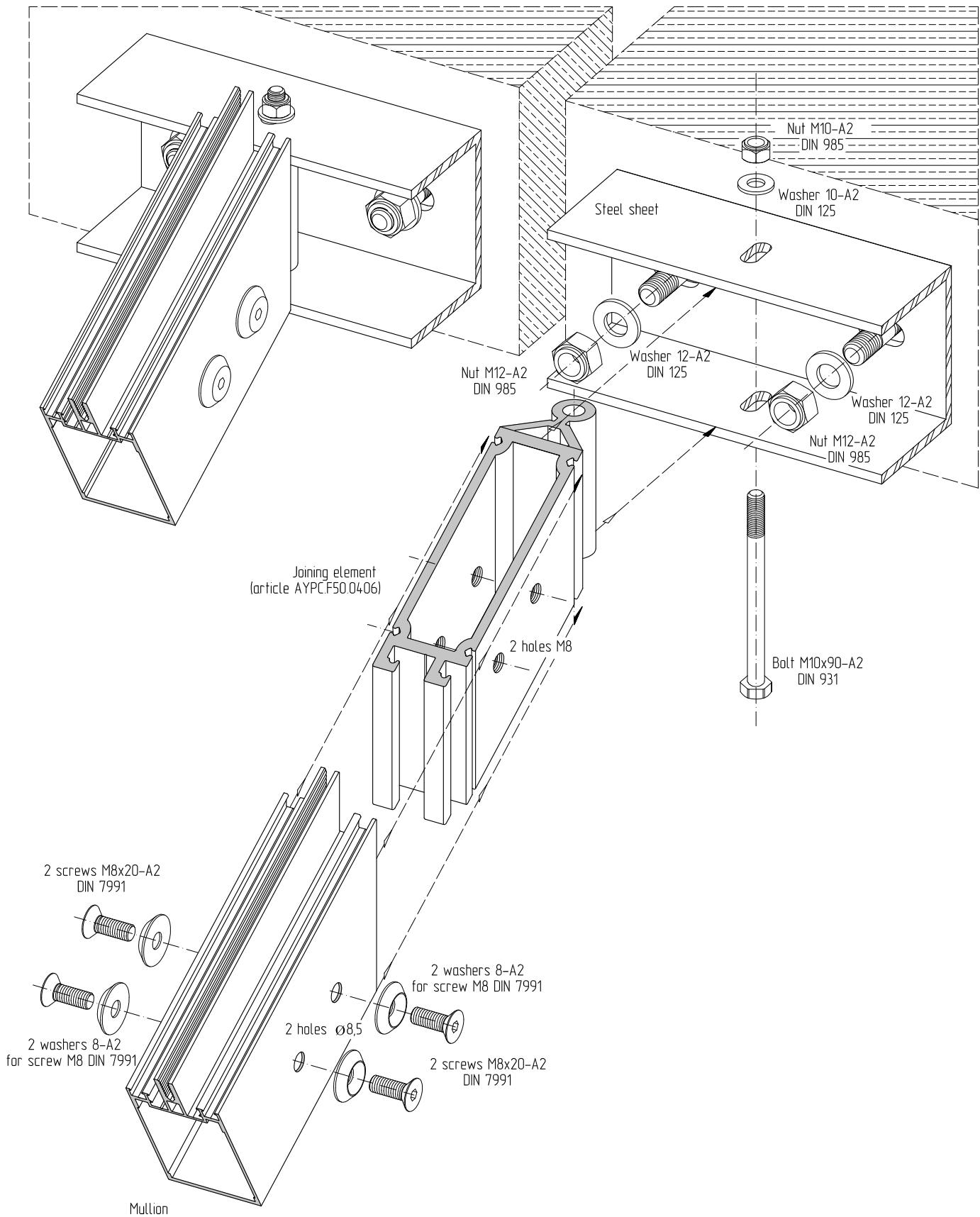



Inclined fixation of mullions

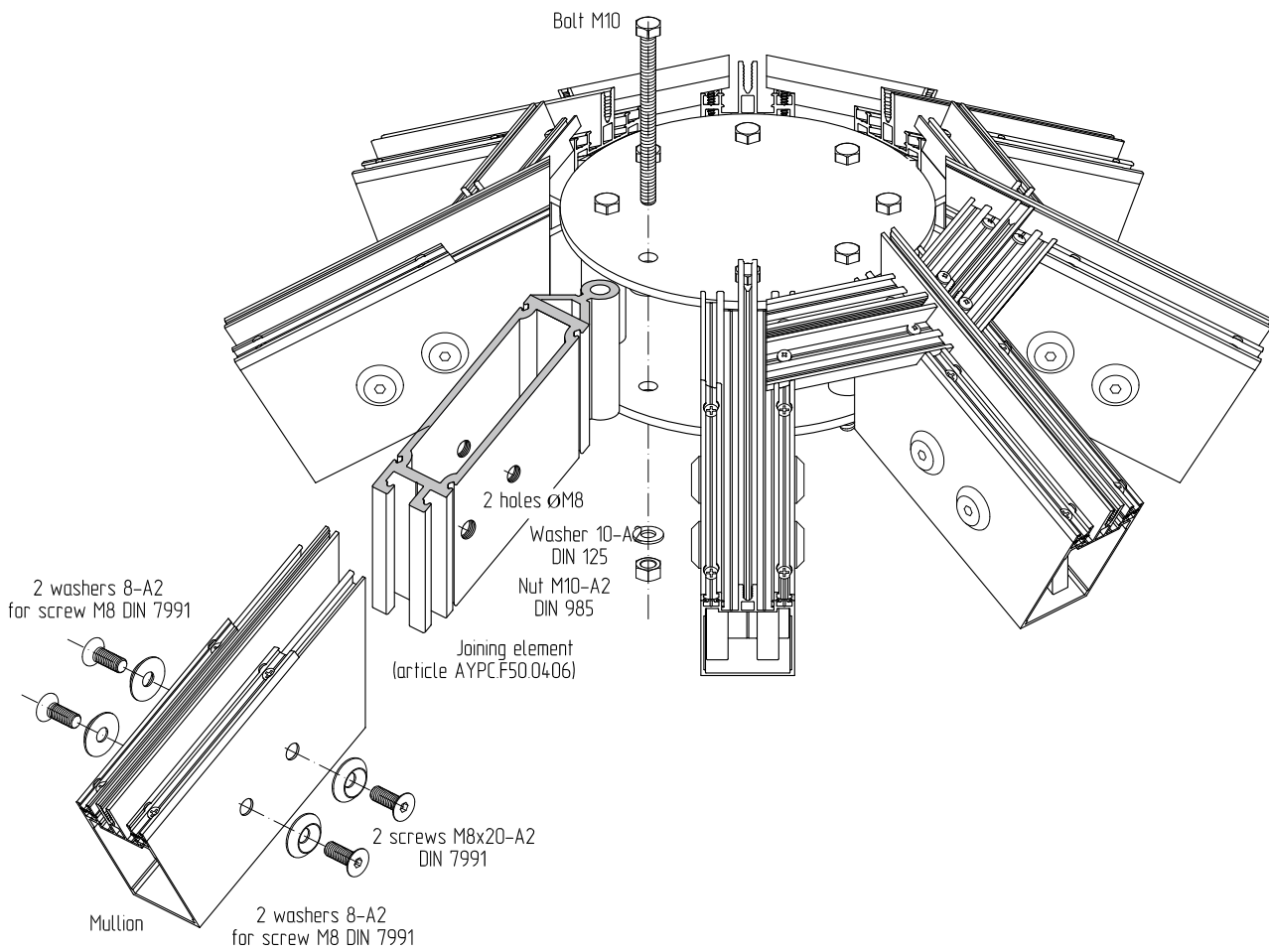
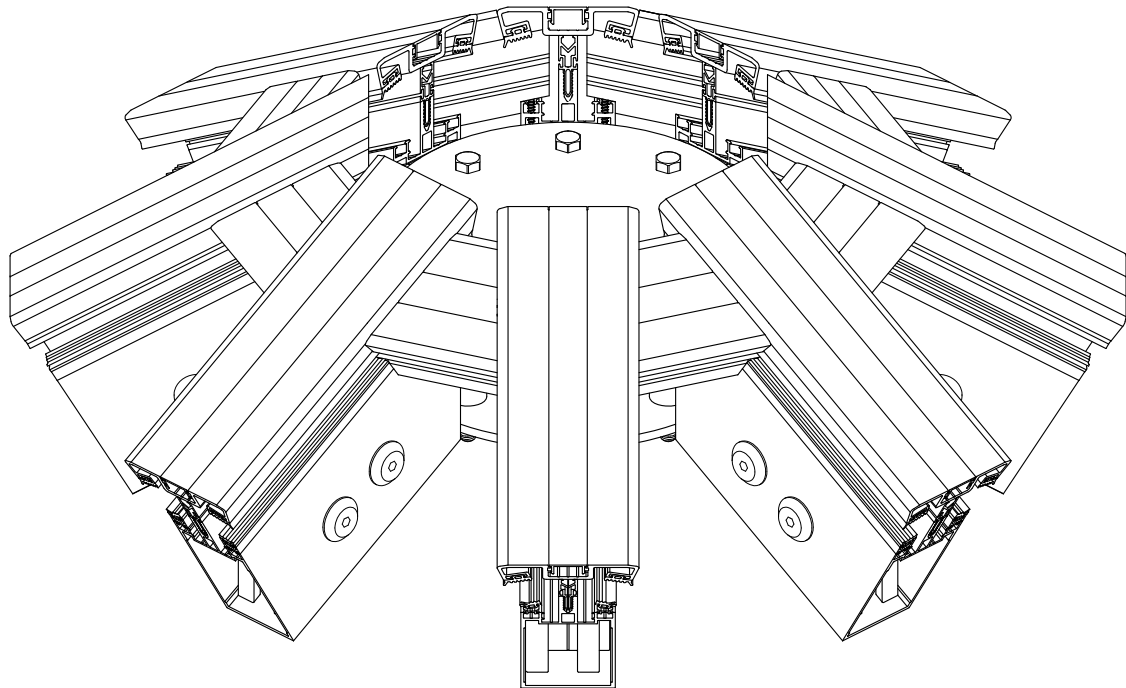

Connection of mullions at the plane of glass unit

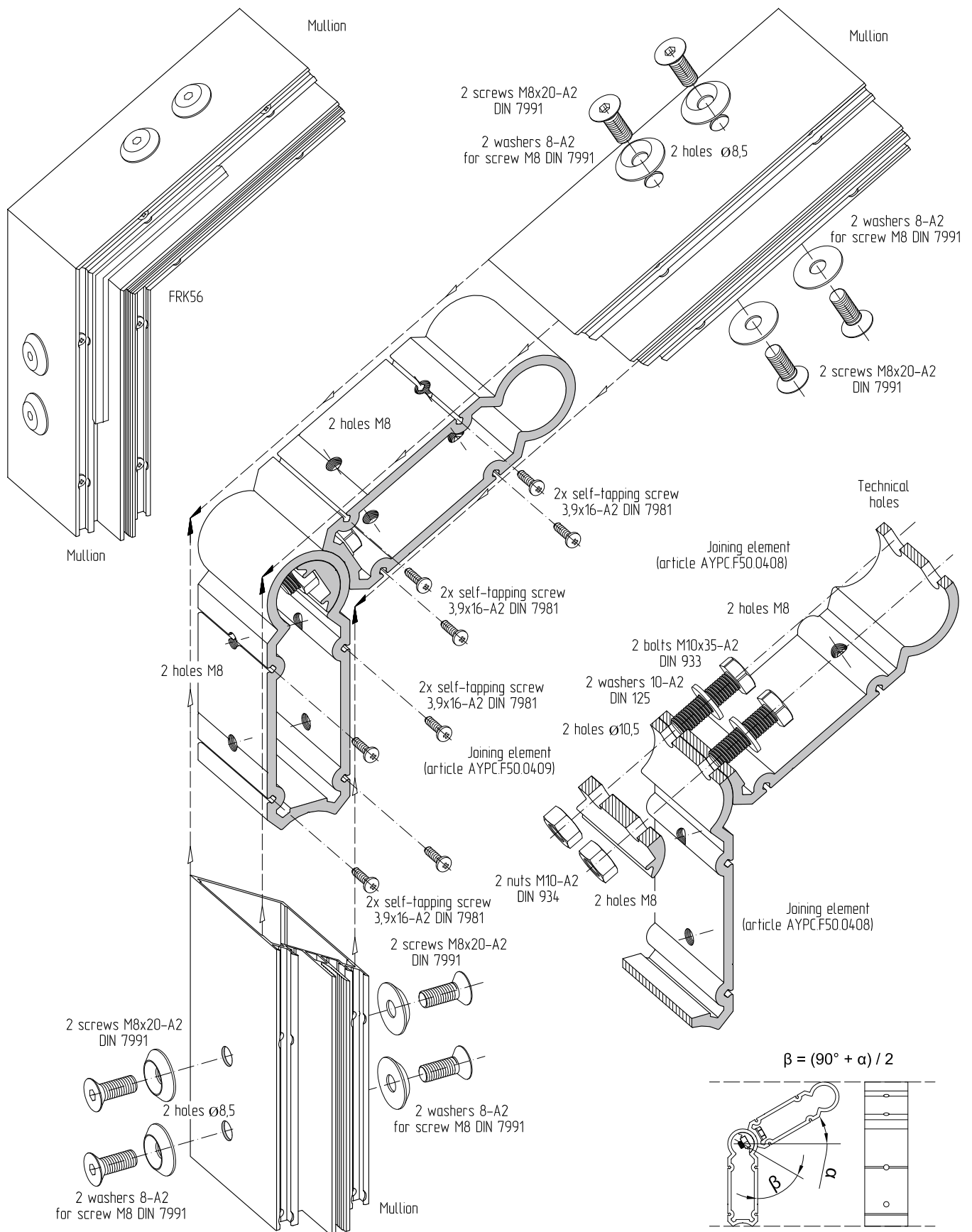

Connection of mullions at two planes

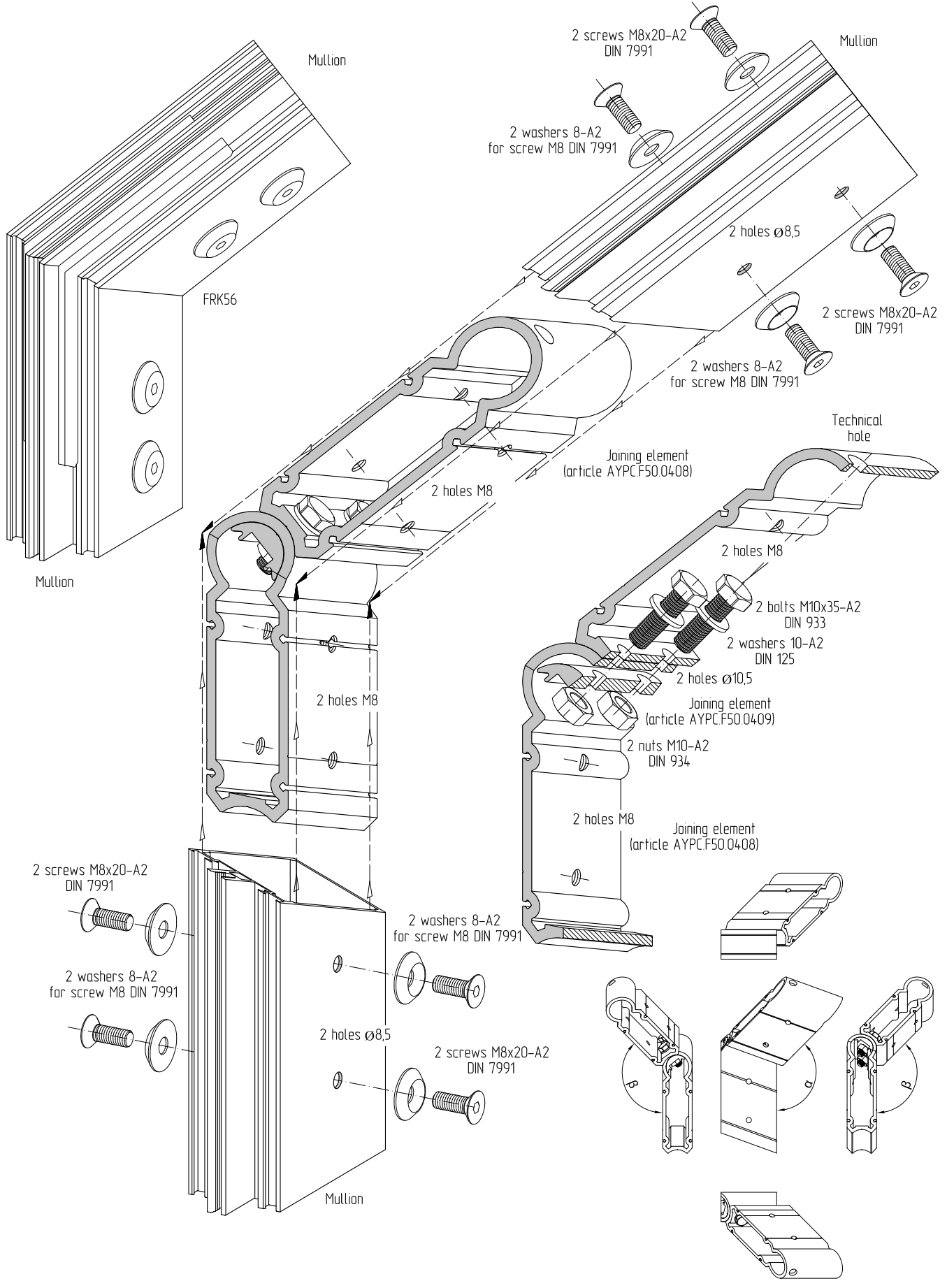





Curved connection of three mullions at two planes

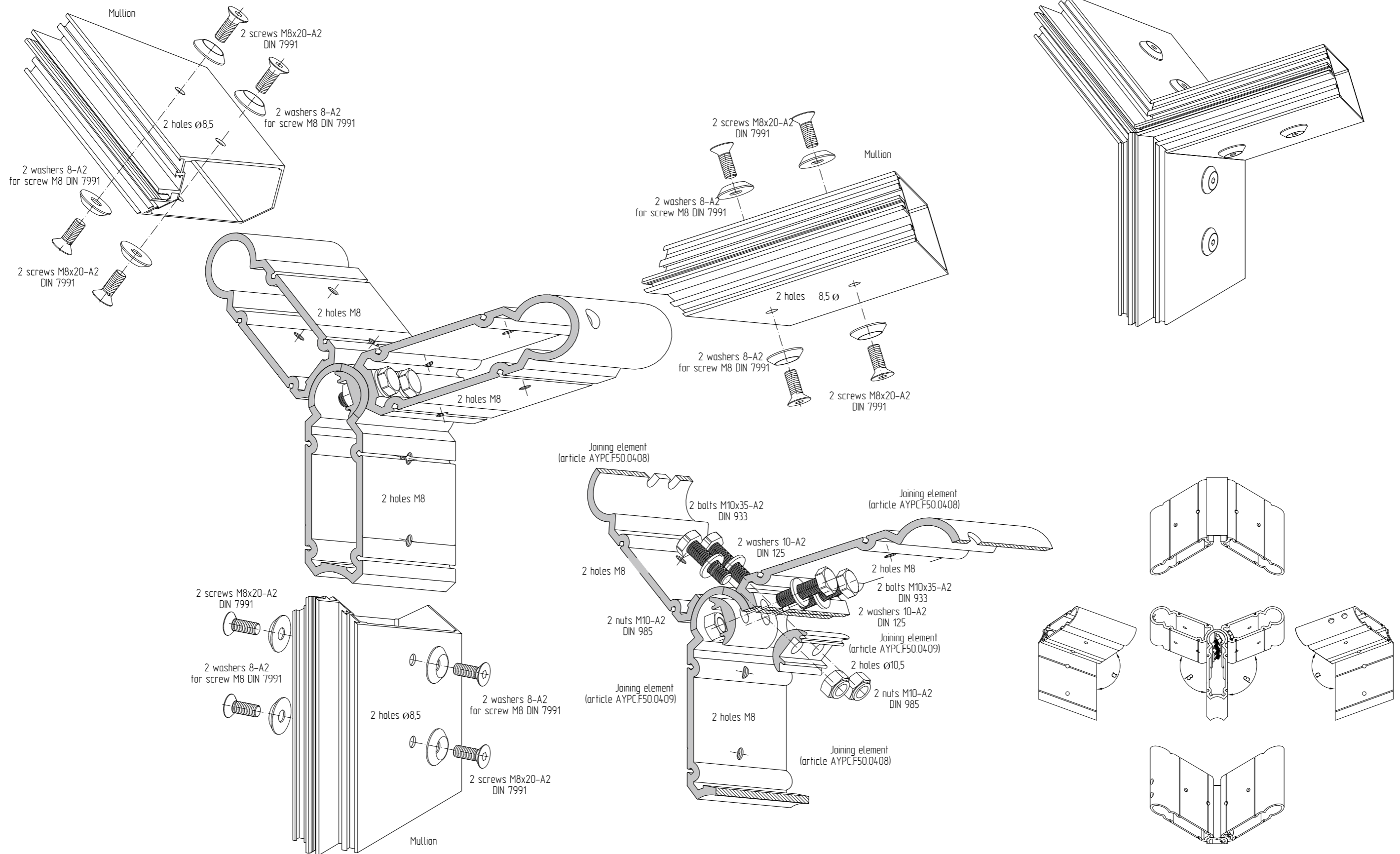



Assemblage of curtain wall construction to steel bearing framework

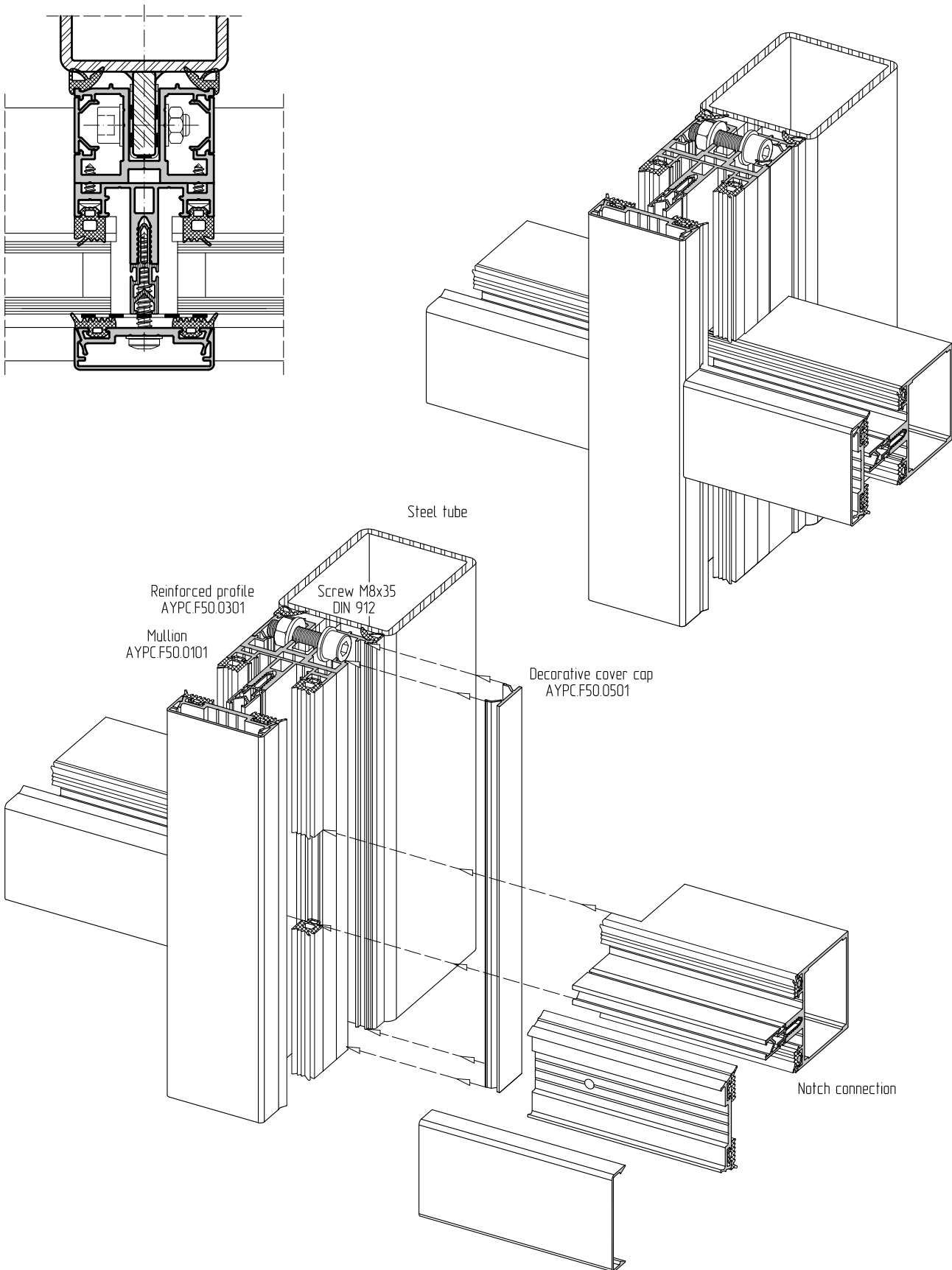

Assemblage of curtain wall construction to wood bearing framework

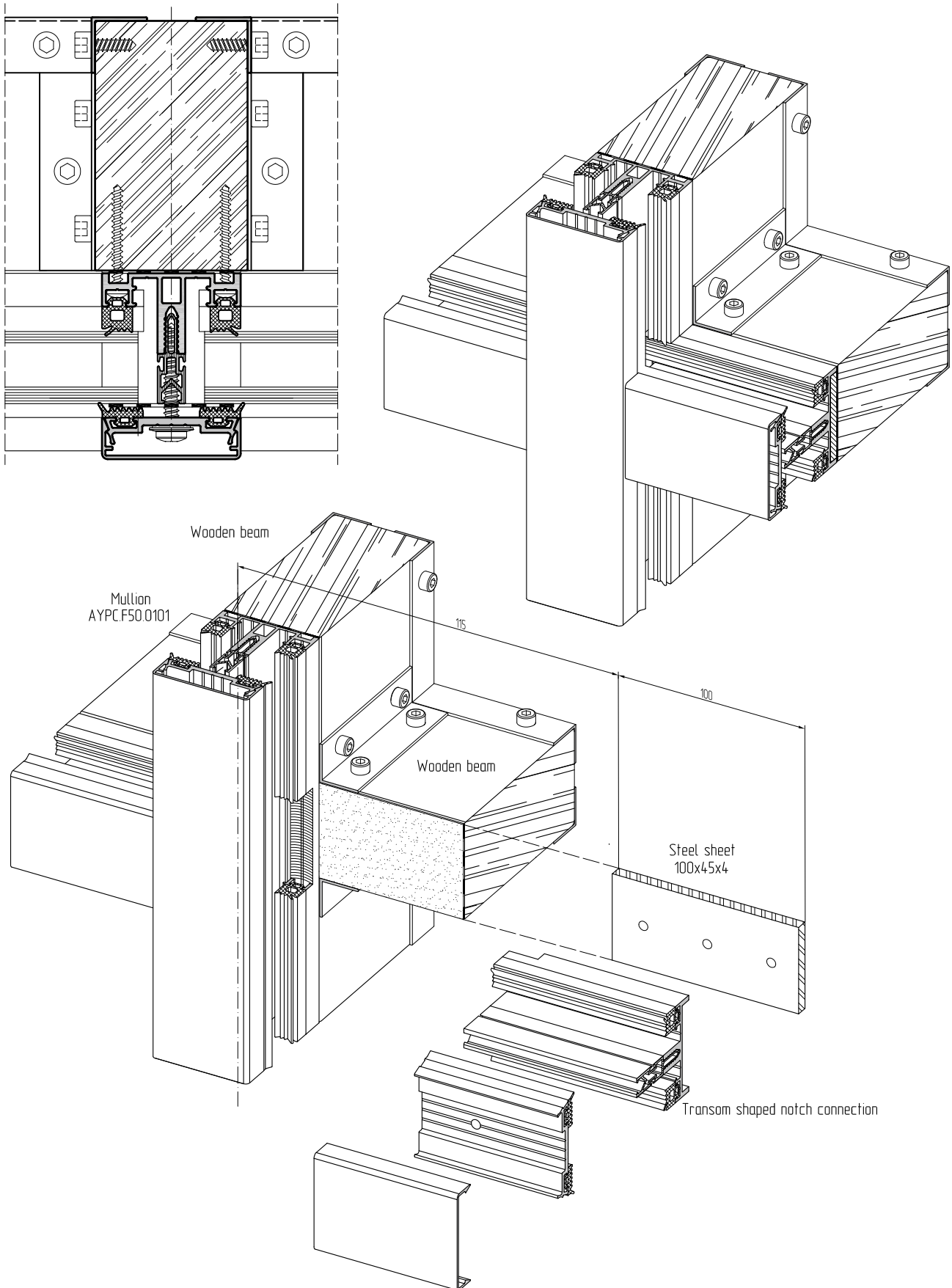





Installation of gaskets FRK14-FRK22 on mullions and transoms

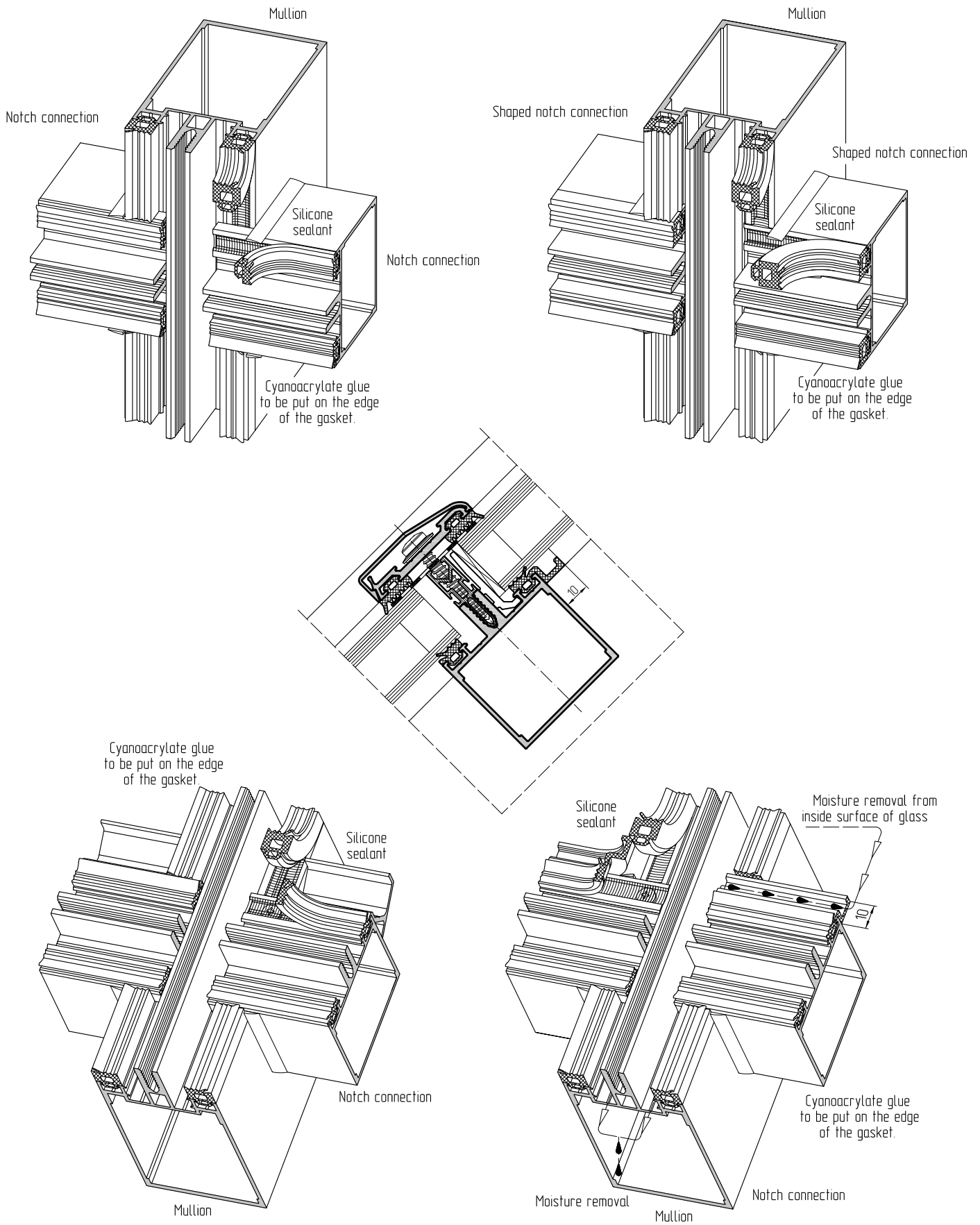

Gasket installation into clamp bar profile FRK24-FRK25

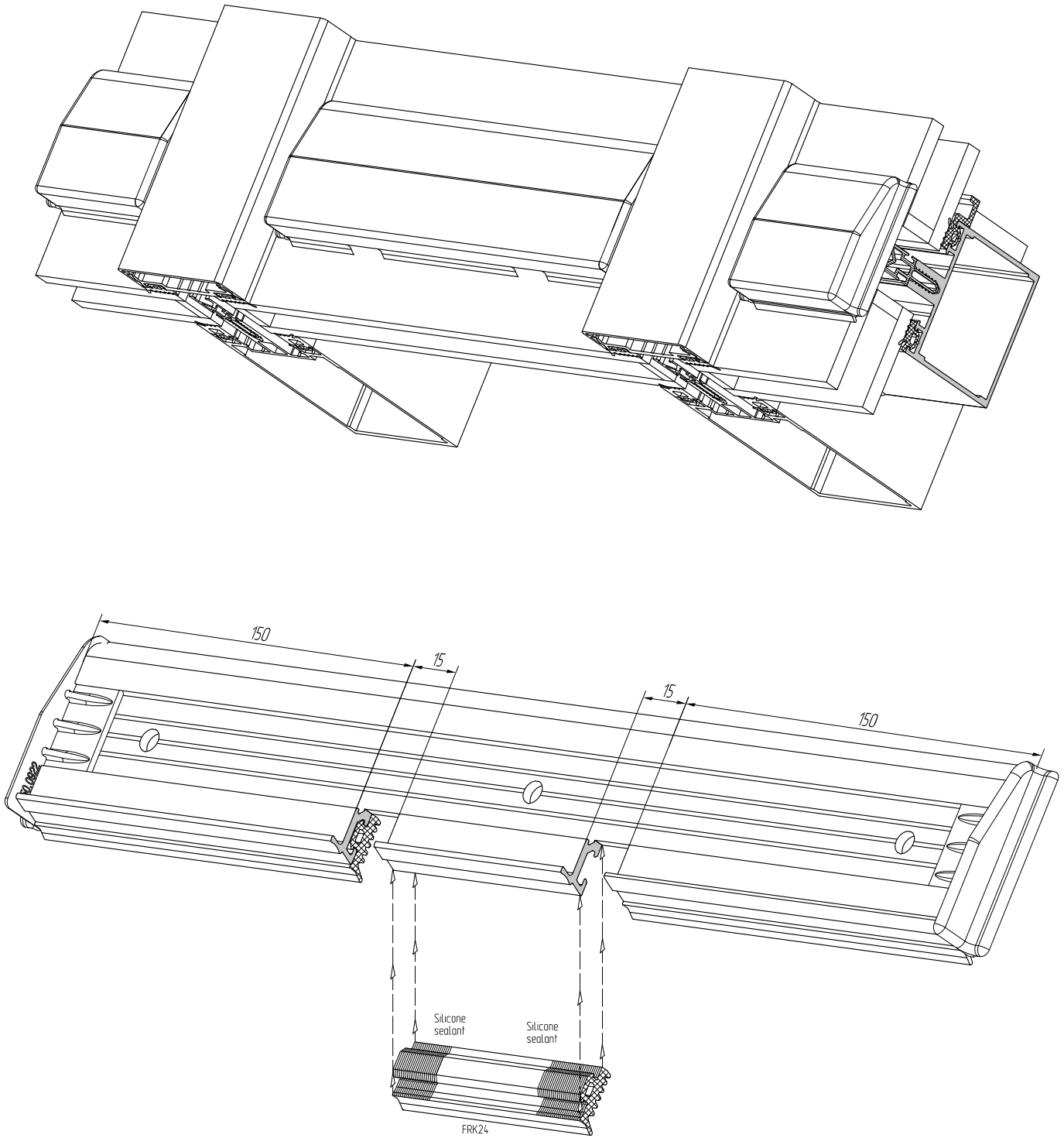

Installation of AYPC.F50.0901-AYPC.F50.0903 distance PVC profiles at the opaque part of the construction notch connection of mullions and transoms

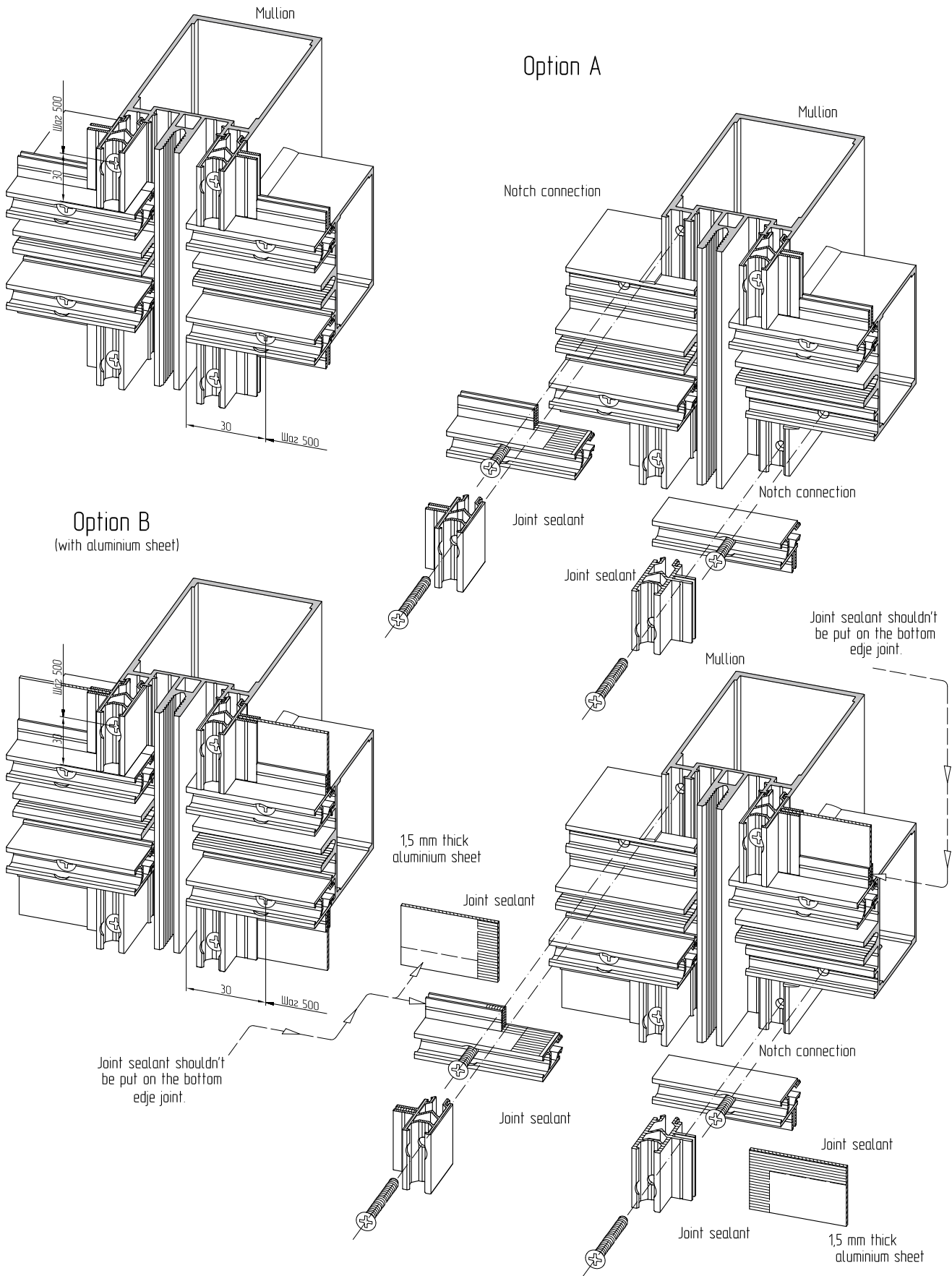

Installation of AYPC.F50.0901-AYPC.F50.0903 distance PVC profiles at the opaque part of the construction shaped notch connection of mullions and transoms

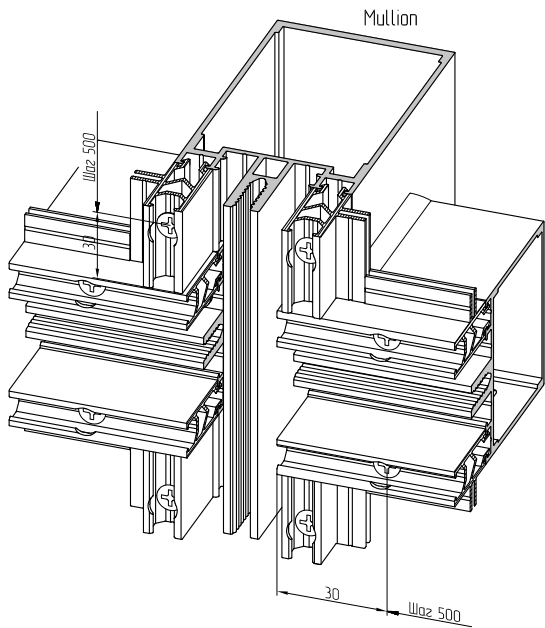

Option B  
(with aluminium sheet)

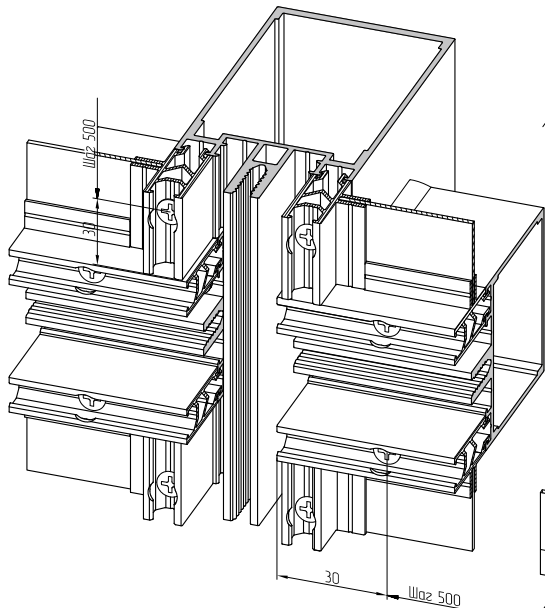

Joint sealant shouldn't be put on the bottom edge joint.

Option A

Shaped notch connection

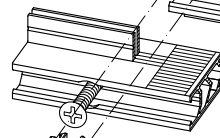

Joint sealant

Screw 3,9x32  
(see table of glazing)

Notch shaped connection

1,5 mm thick aluminium sheet

Joint sealant

Joint sealant

Mullion

Shaped notch connection

Joint sealant shouldn't be put on the bottom edge joint.

Mullion

Shaped notch connection

Joint sealant

1,5 mm thick aluminium sheet

Joint sealant

Mounting of plastic edge plug AYPC.F50.0921 at the connection of transom and mullion.

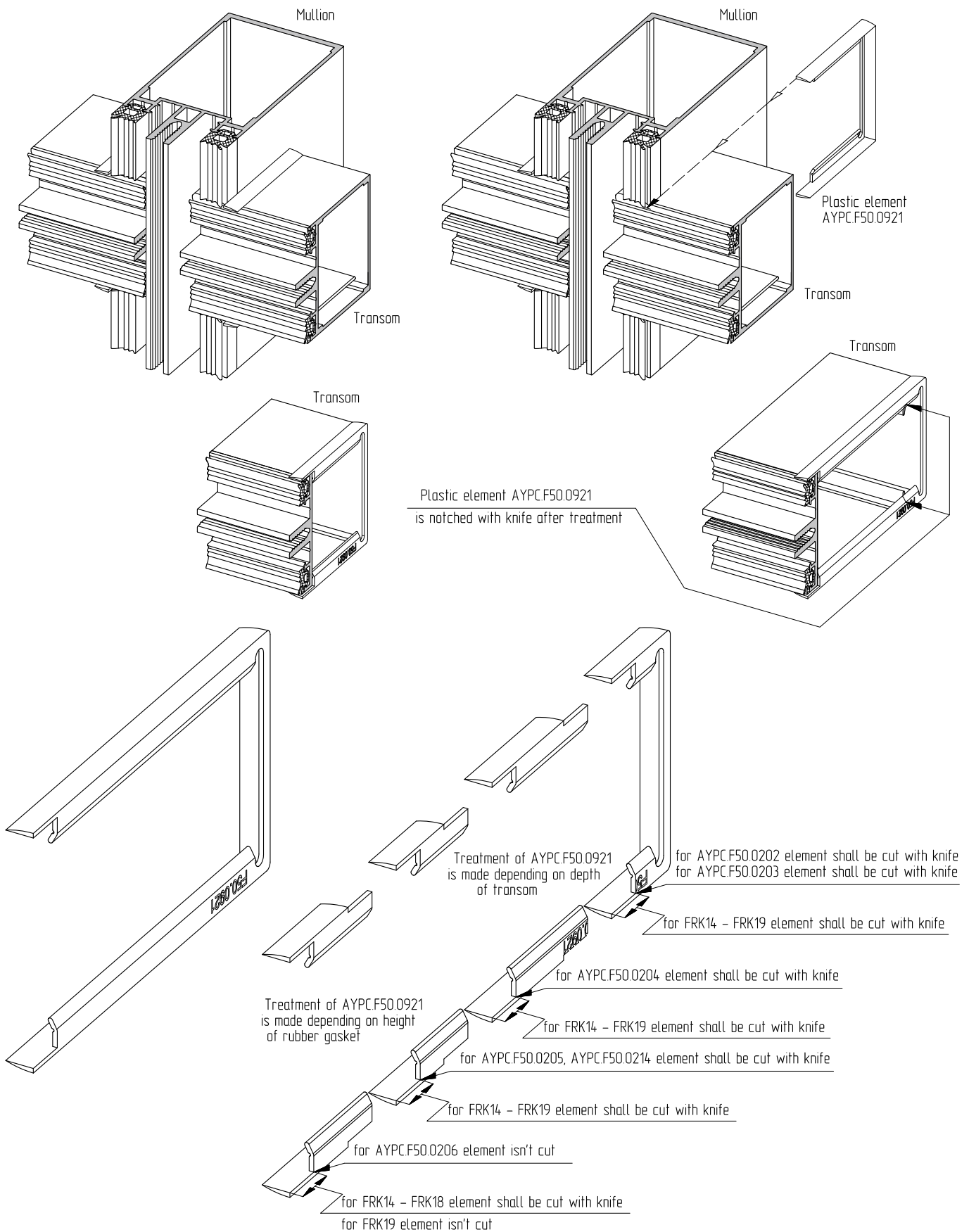

Mounting of plastic edge plug AYPC.F50.0921-01 at the connection of transom and mullion.

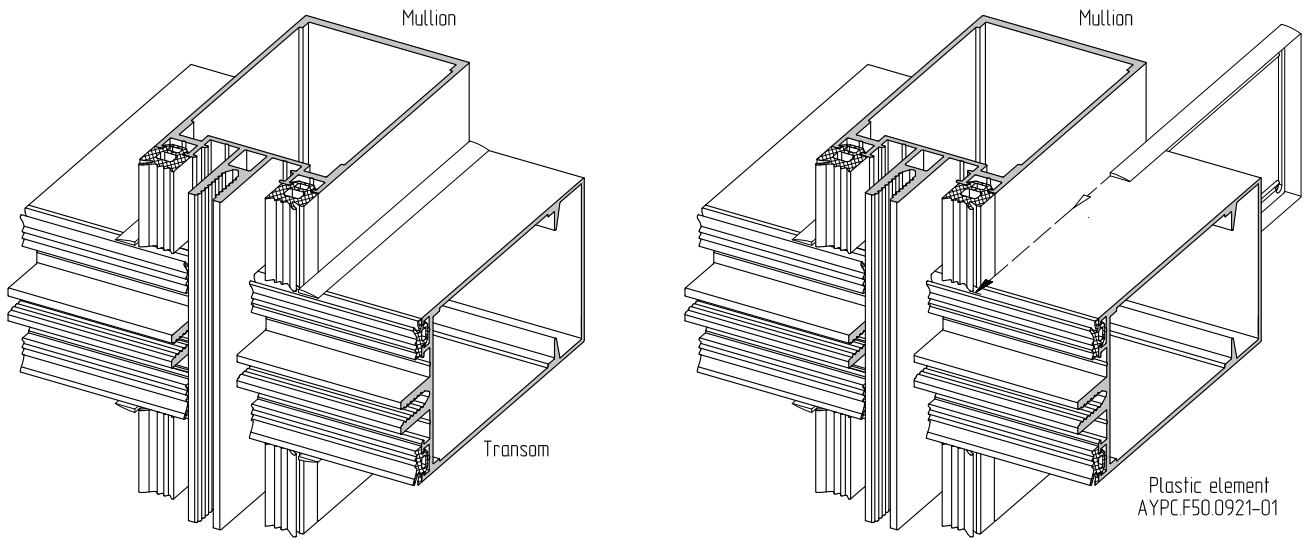

Plastic element AYPC.F50.0921-01 is notched with knife after treatment

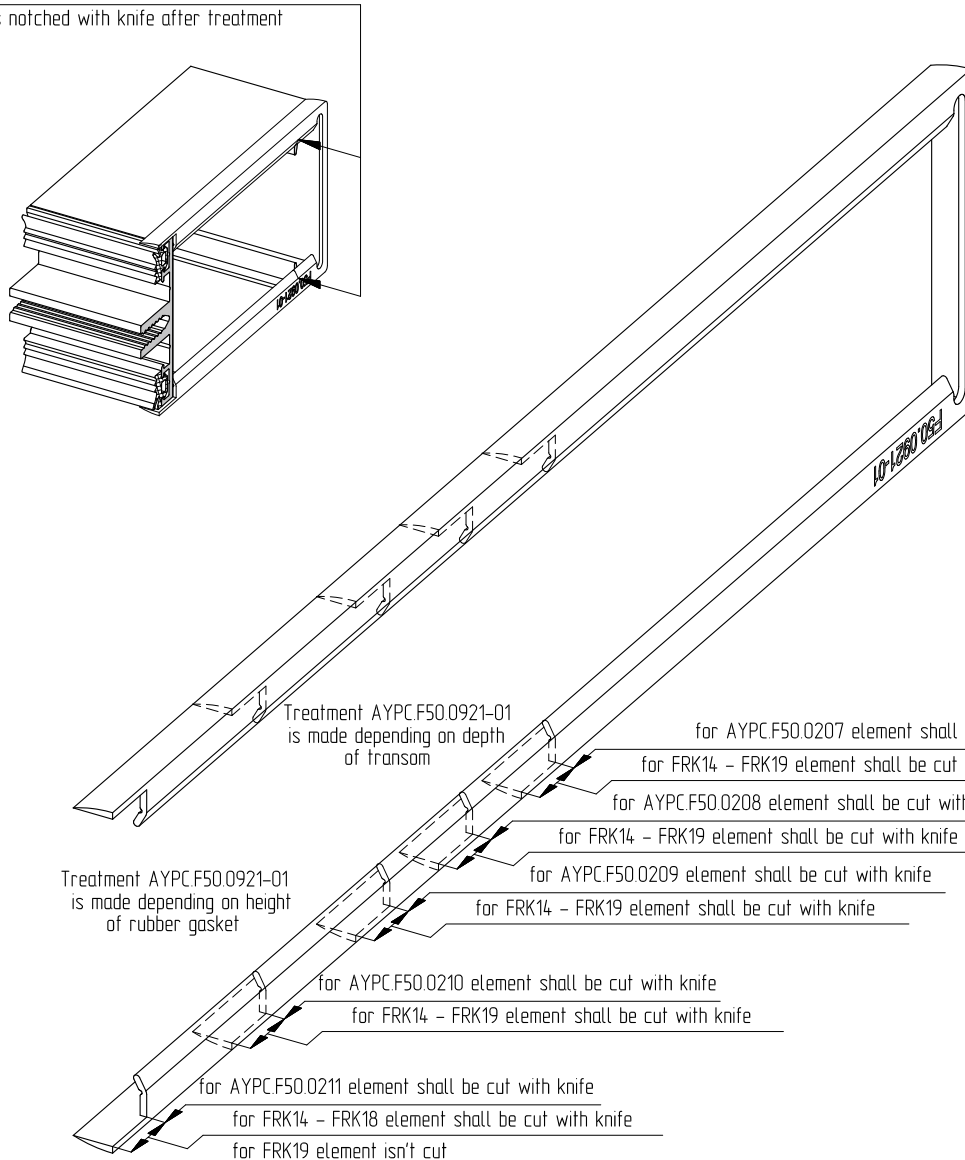



Mounting of plastic edge plug AYPC.F50.0921-02 at the connection of transom and mullion.

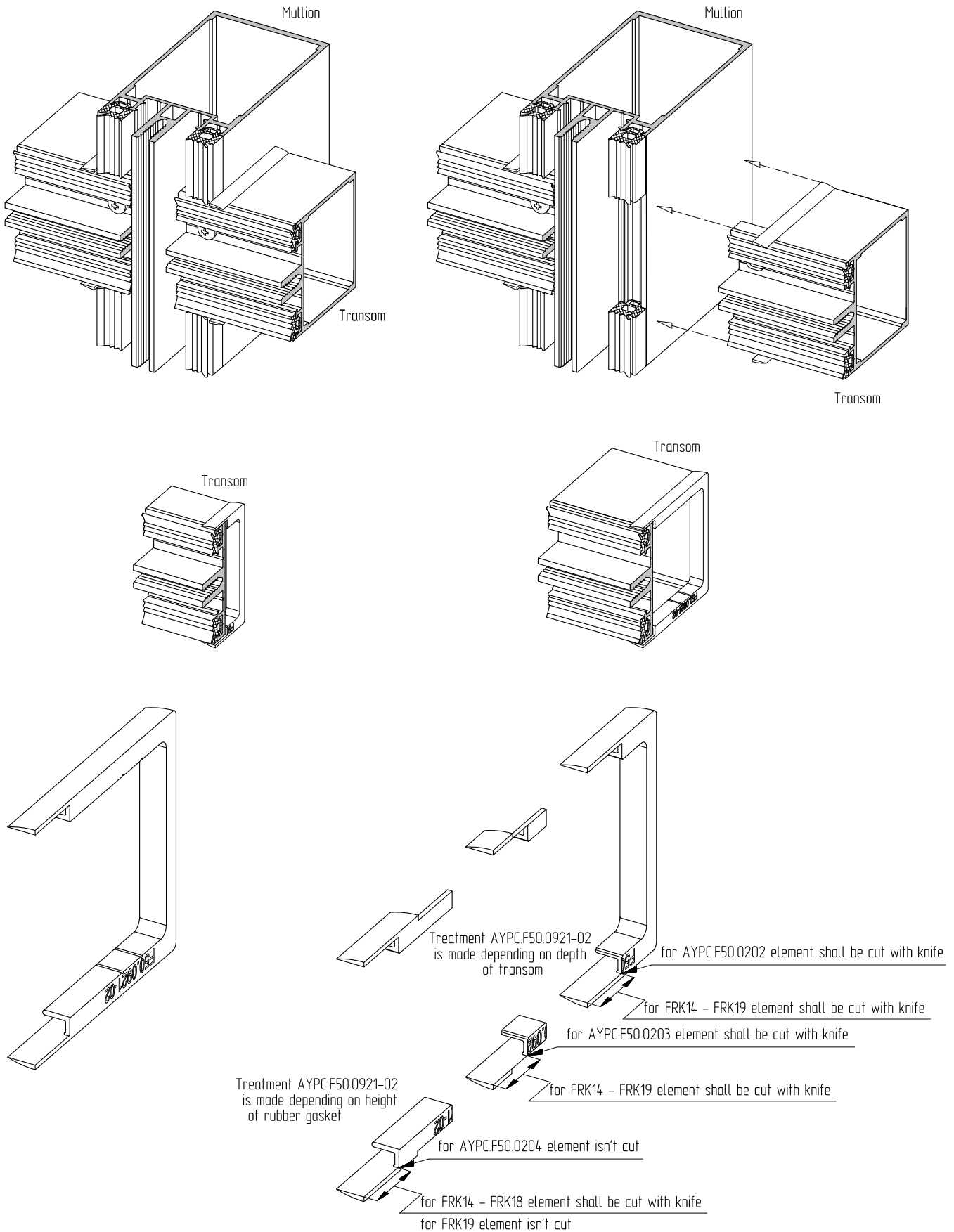



Mounting of plastic edge plugs AYPC.F50.0922 at the edges of transom clamps and cover caps on inclined surfaces

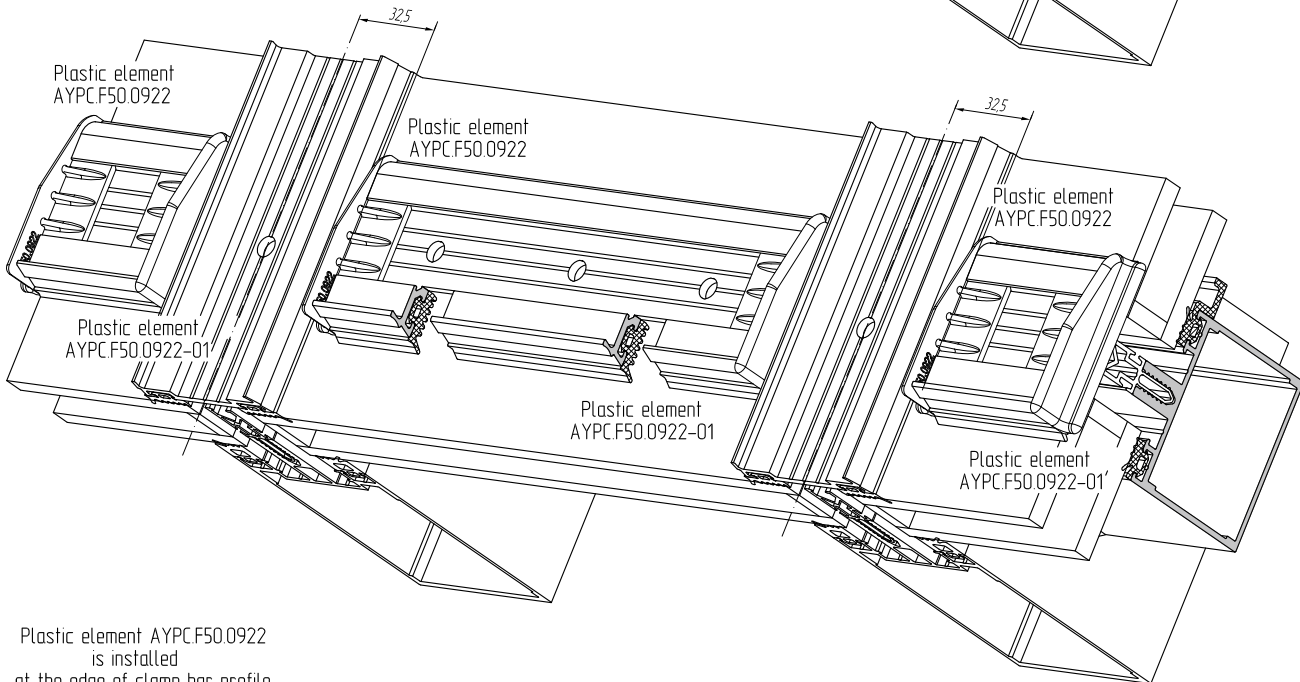
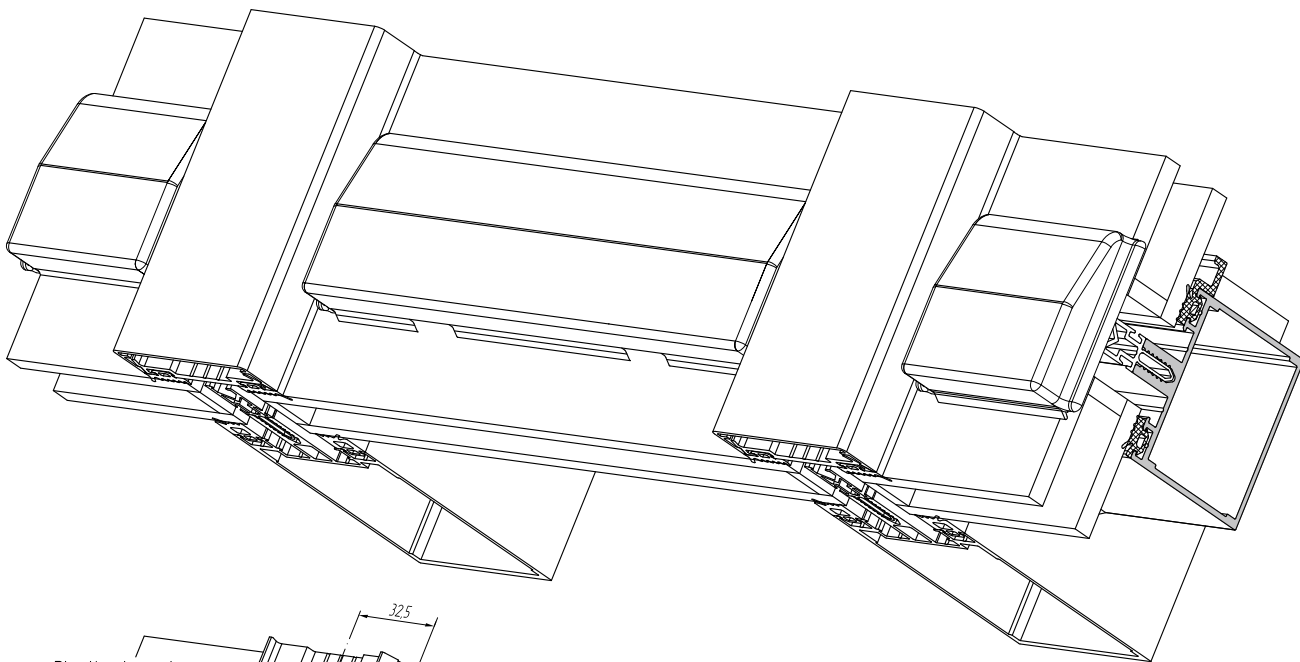

Plastic element AYPC.F50.0922 is installed at the edge of clamp bar profile.

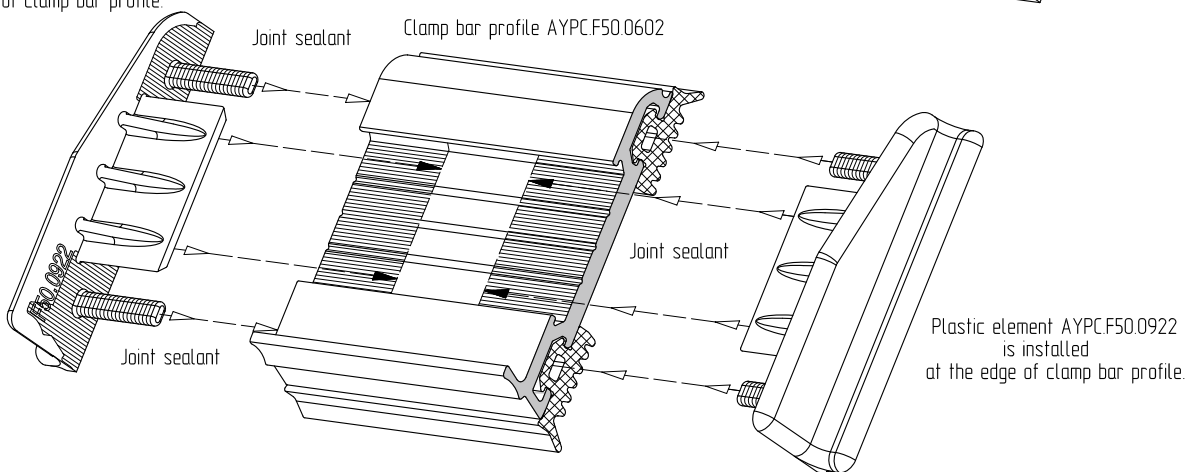

Installation of RFK161 plastic end stop plug on butt-ends of transom clamp and covers of inclined surface.

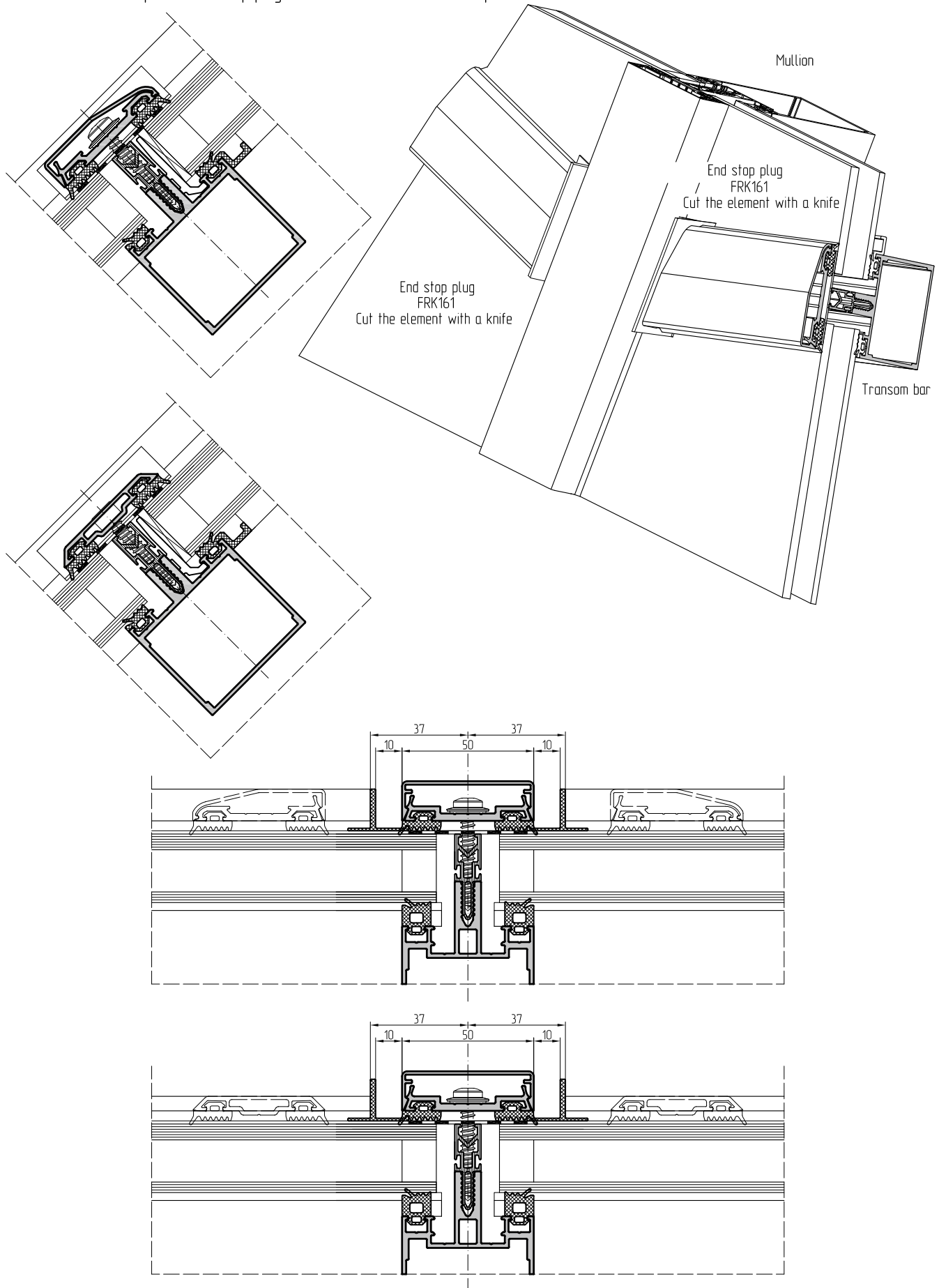

Mounting of plastic drain AYPC.F50.0923 to mullion drain trays

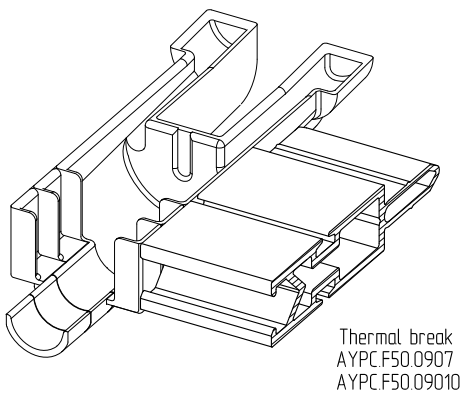
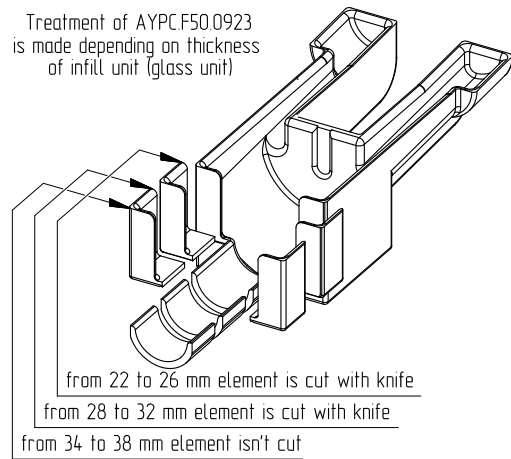
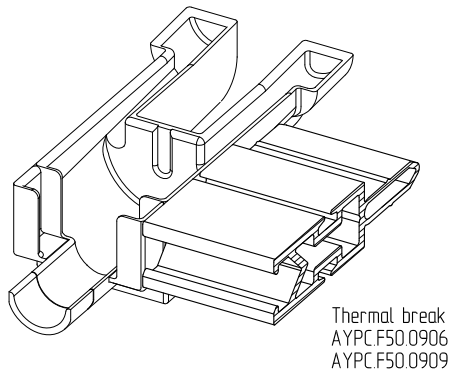
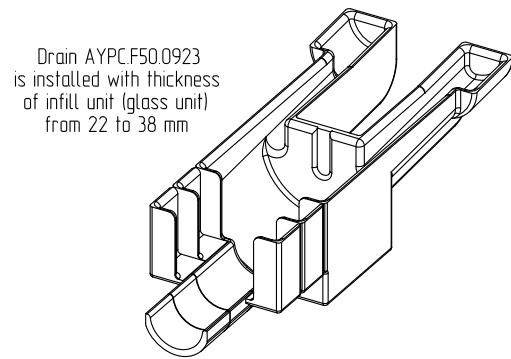
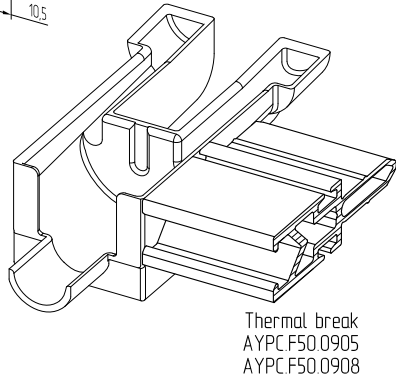
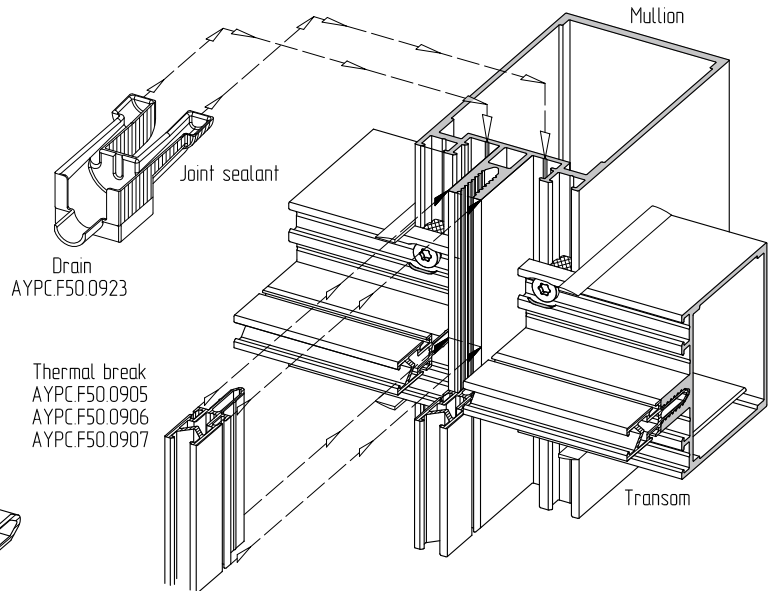
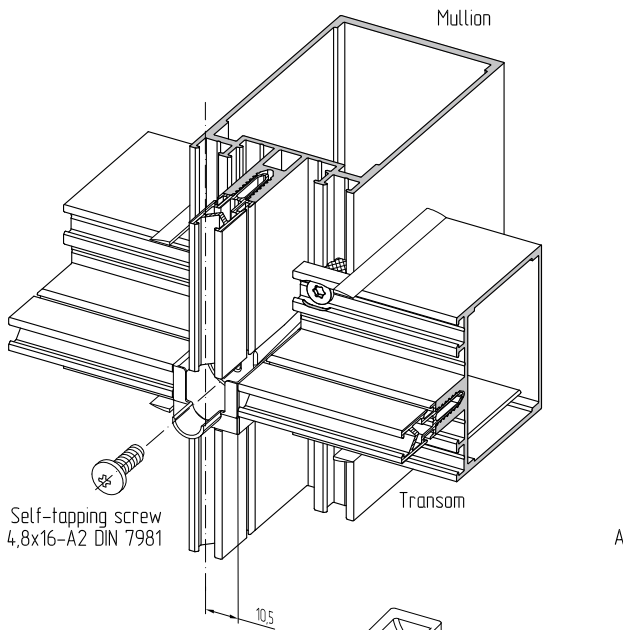

Mounting of plastic drain AYPC.F50.0923 to mullion drain trays

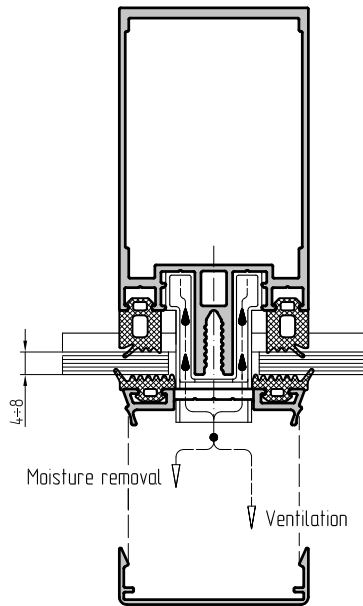
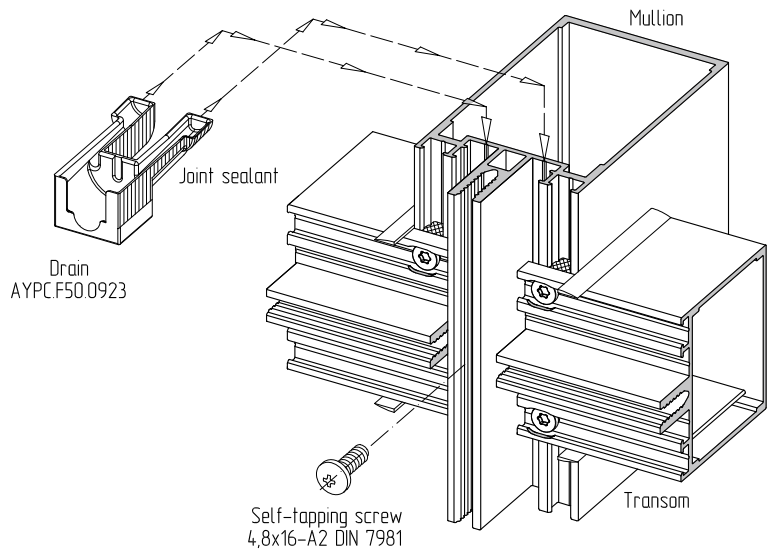
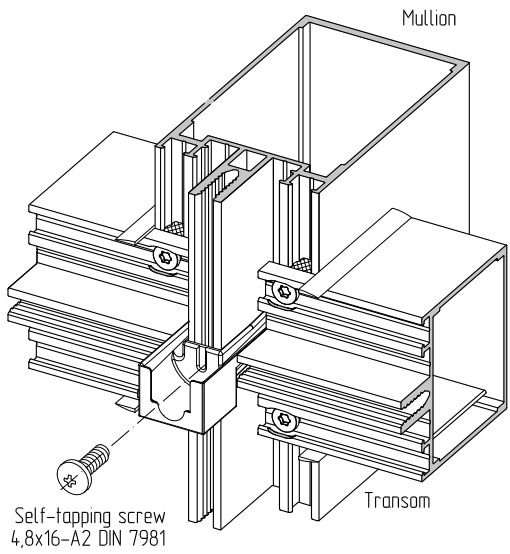

Moisture removal and ventilation are realised through holes in vertical clamp bars.

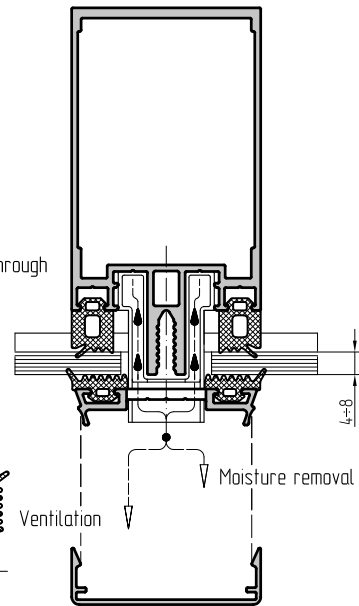
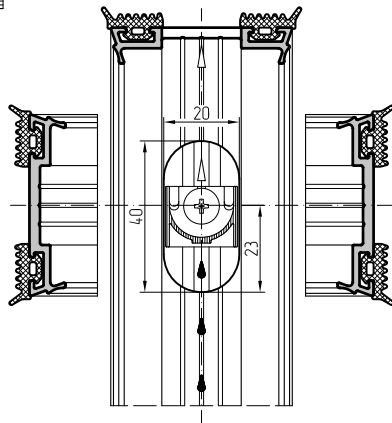

Drain AYPC.F50.0923 is installed with the infill unit (glass unit) from 4 to 8 mm

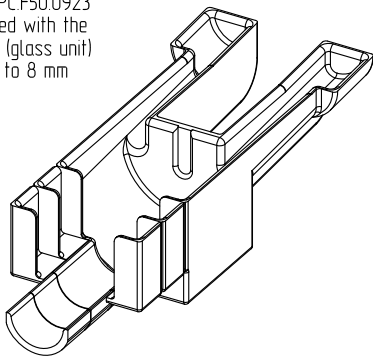

Treatment of AYPC.F50.0923 for infill unit (glass unit) from 4 to 8 mm

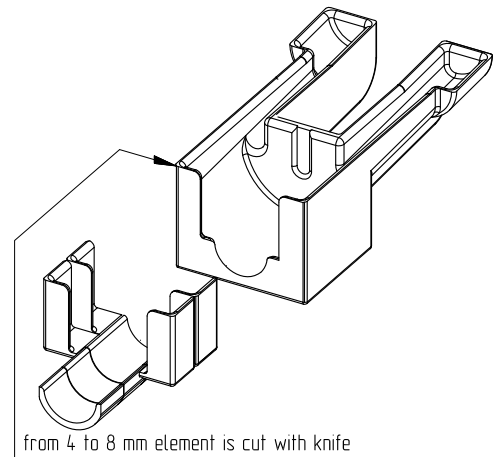

Mounting of rubber drain AYPC.F50.0928 to mullion drain trays

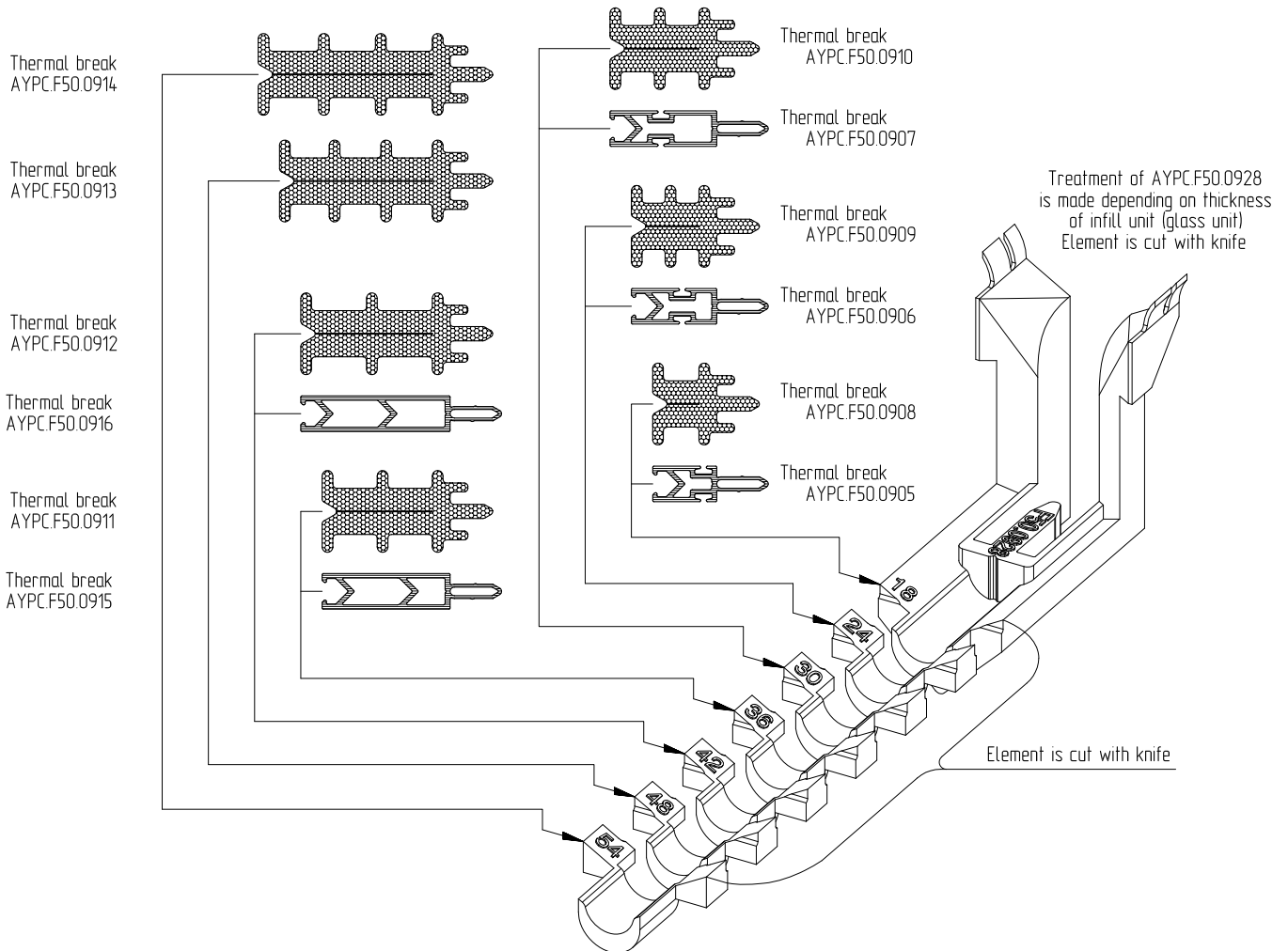
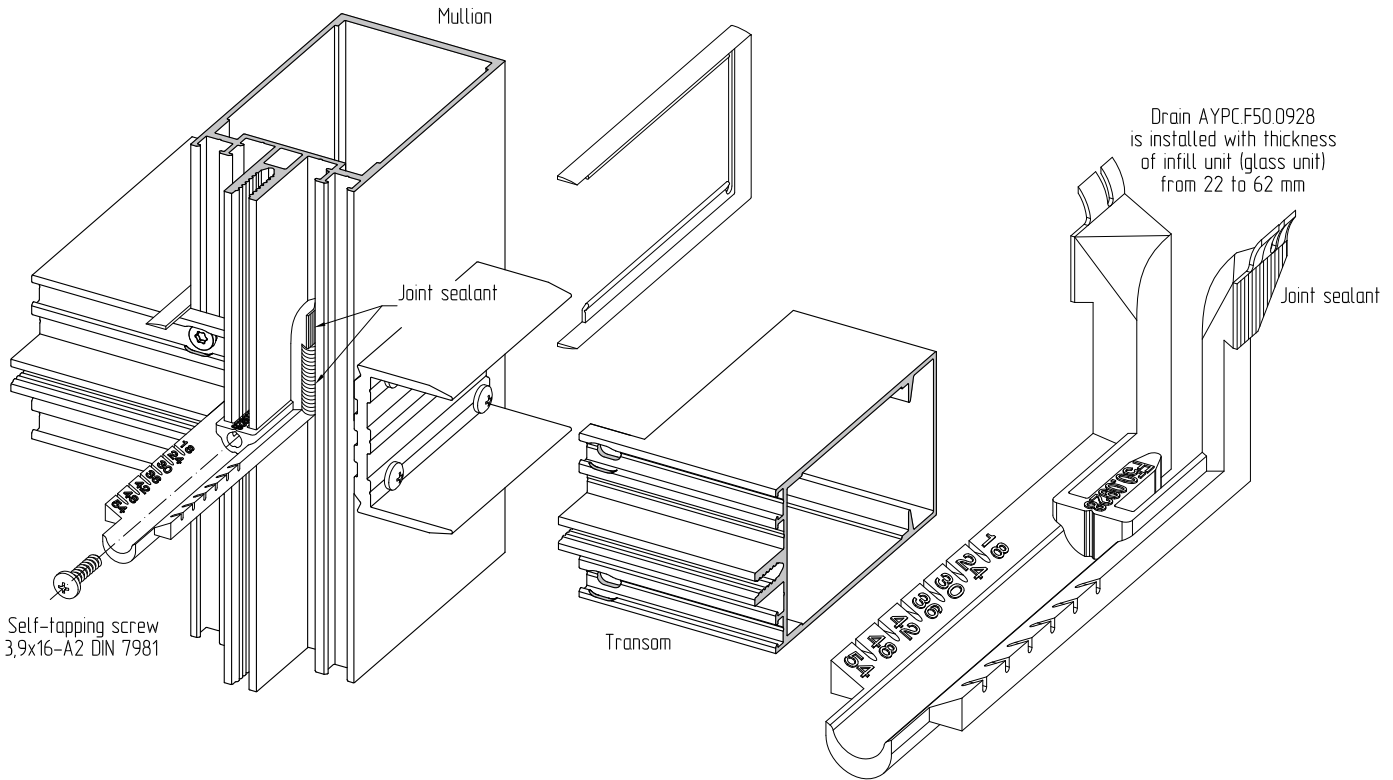

Mounting of plastic edge plugs AYPC.F50.0924 at the connection place of transom and mullion

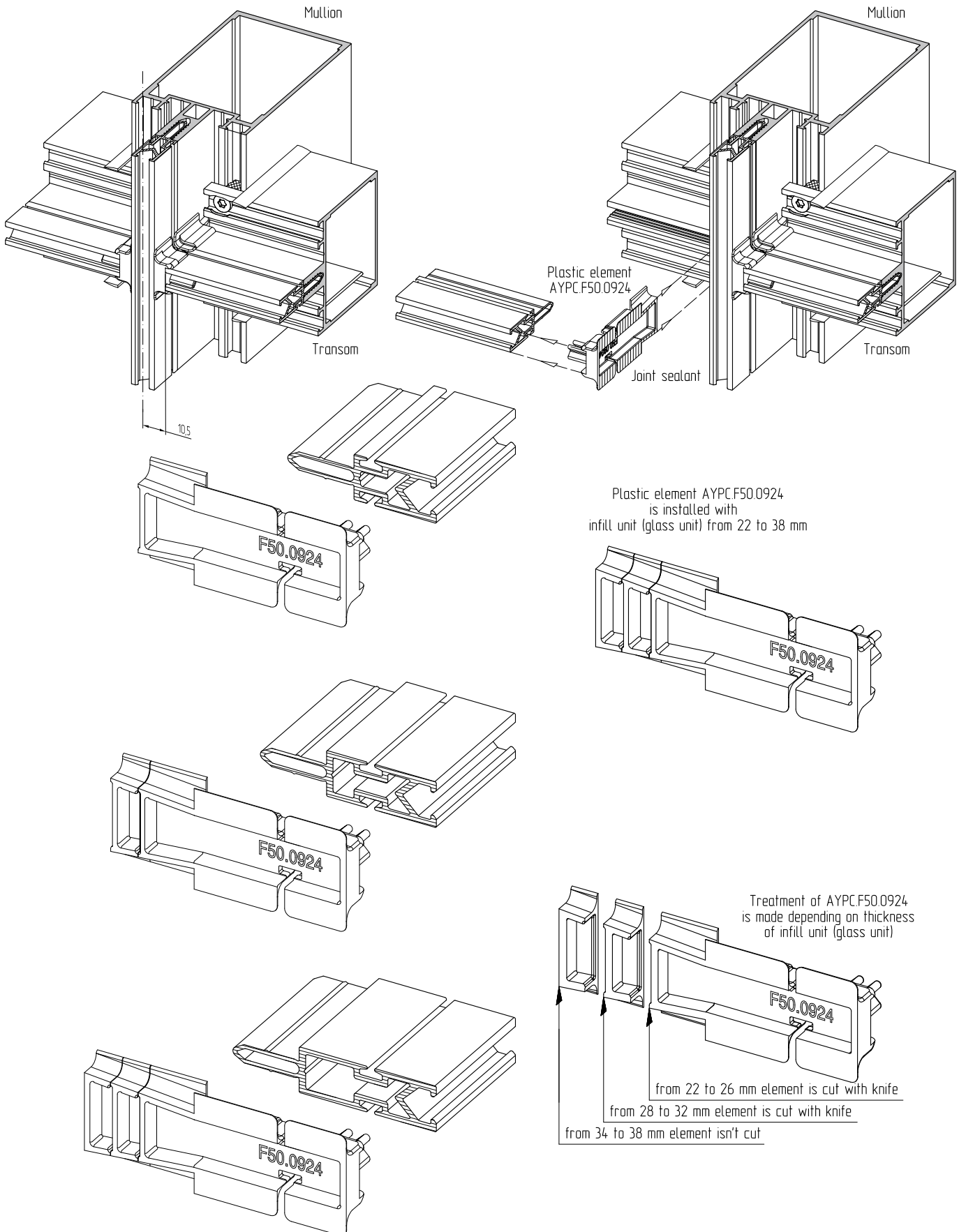



Mounting of plastic plugs AYPC.F50.0925, AYPC.F50.0926 at the vertical connection of mullions

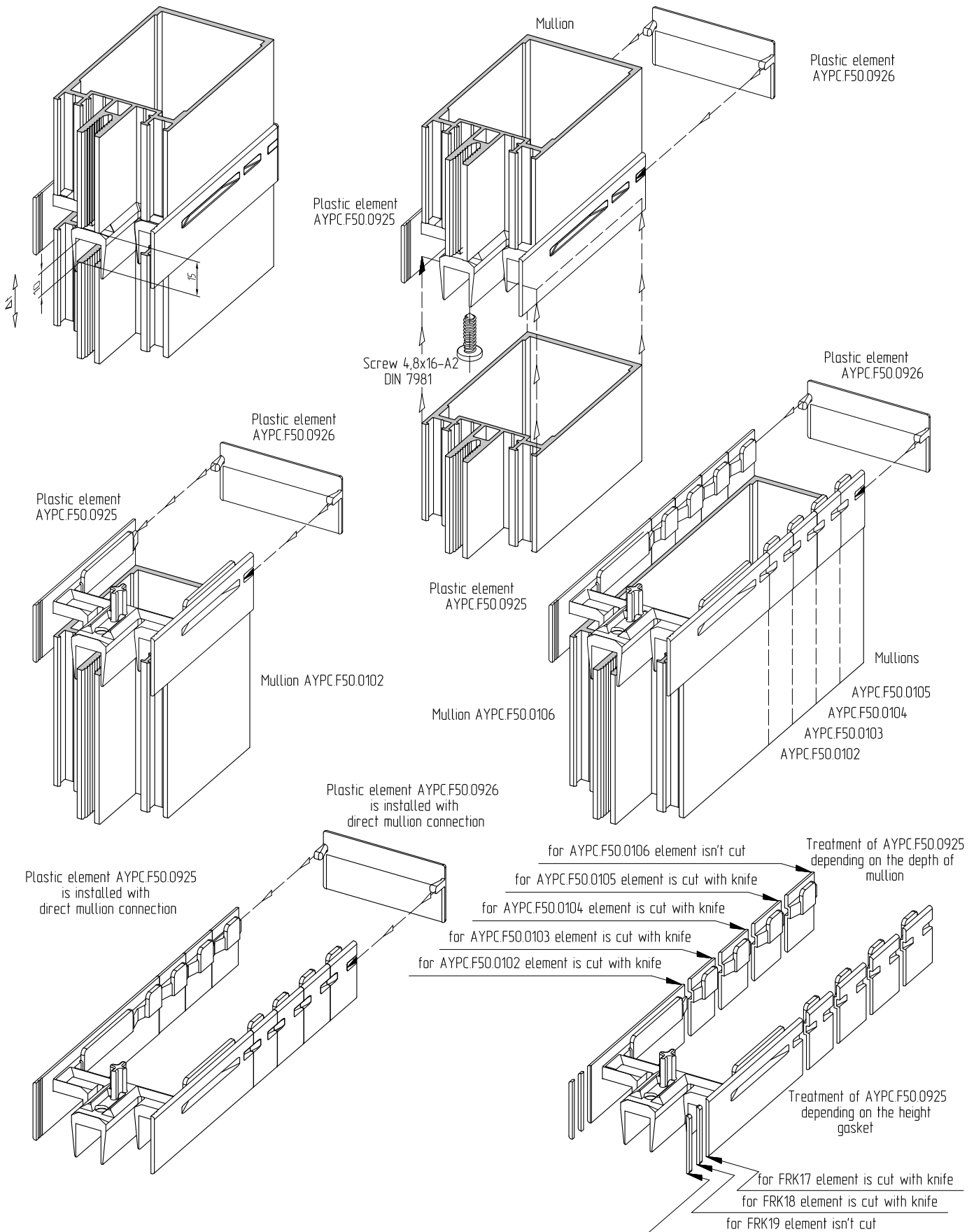

Installation of AYPC.F50.0925-01, AYPC.F50.0925-03, AYPC.F50.0926 plastic plug stops on the vertical connection of mullions

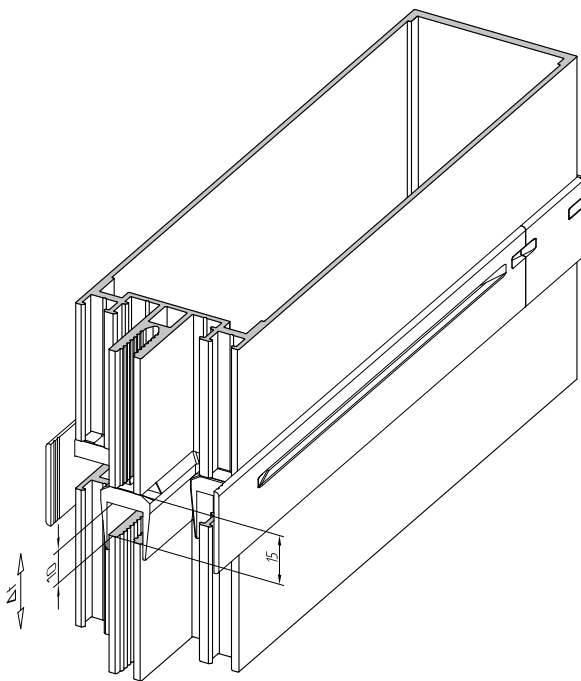

Plastic element AYPC.F50.0926 is installed in the process of direct mullion connection.

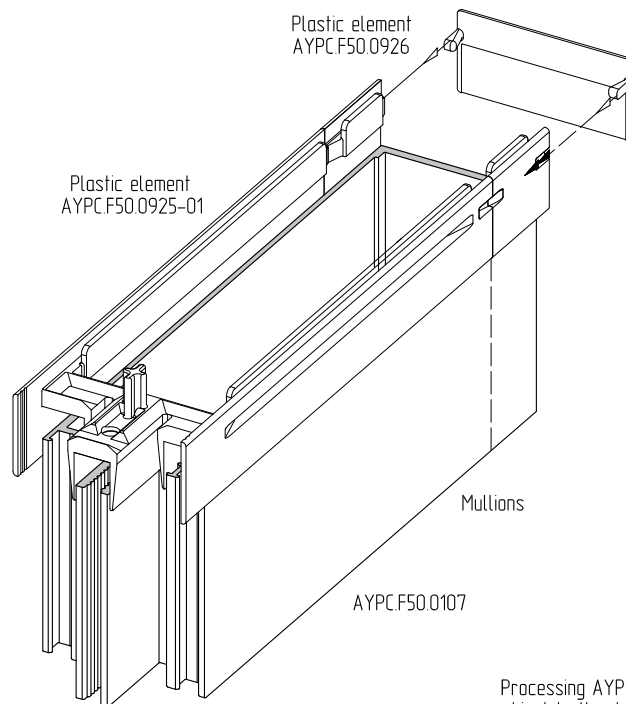

Processing AYPC.F50.0925-01 subject to the depth of mullions

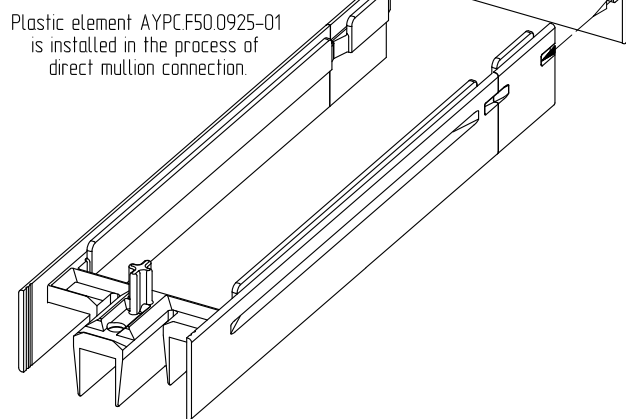

Plastic element AYPC.F50.0925-01 is installed in the process of direct mullion connection.

for AYPC.F50.0108 the element mustn't be cut

for AYPC.F50.0107 the element mustn't be cut

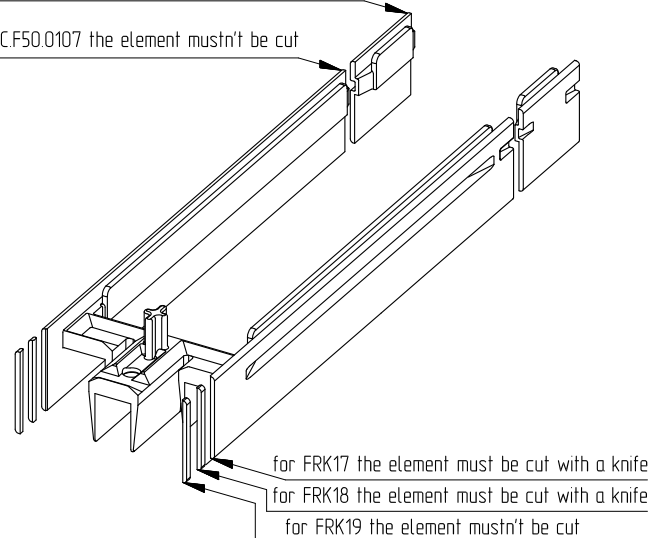

for FRK17 the element must be cut with a knife  
for FRK18 the element must be cut with a knife  
for FRK19 the element mustn't be cut

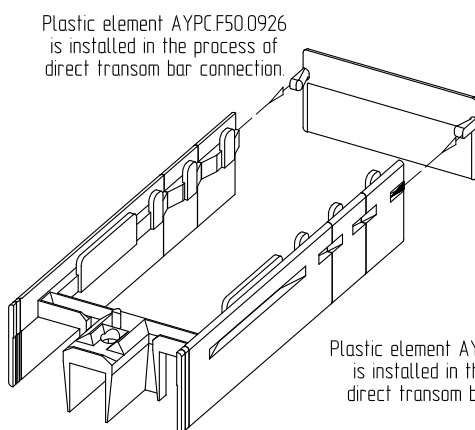

Plastic element AYPC.F50.0926 is installed in the process of direct transom bar connection.

for AYPC.F50.0207 u AYPC.F50.0227 the element mustn't be cut

for AYPC.F50.0206 u AYPC.F50.0226 the element mustn't be cut

for AYPC.F50.0205 the element must be cut with a knife

Processing of AYPC.F50.0925-03 subject to the depth of transom bar

Plastic element AYPC.F50.0925-03 is installed in the process of direct transom bar connection.

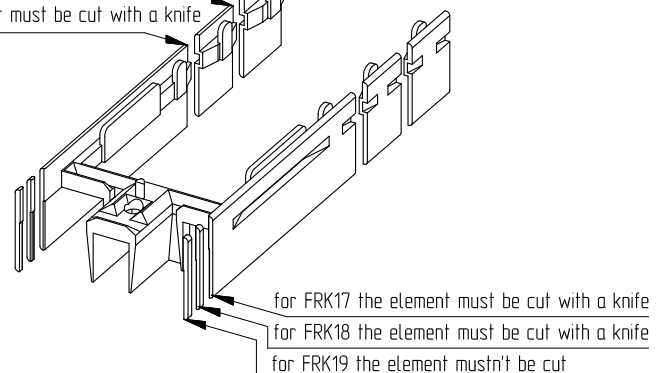

for FRK17 the element must be cut with a knife  
for FRK18 the element must be cut with a knife  
for FRK19 the element mustn't be cut

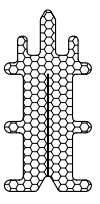
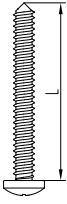

Rubber plug is intended for assigning clamp self-tapping screw in the process of forwarding through thermal break.

	
For thermal breaks	Screw 5,5xL-A4 DIN 7981
AYPC.F50.0911	
AYPC.F50.0912	
AYPC.F50.0913	
AYPC.F50.0914	

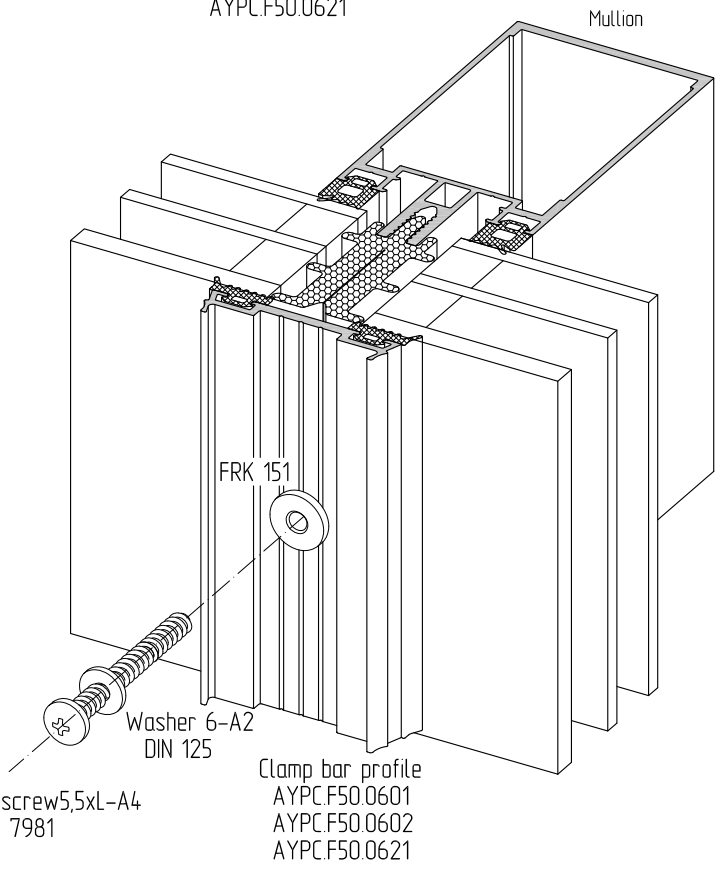
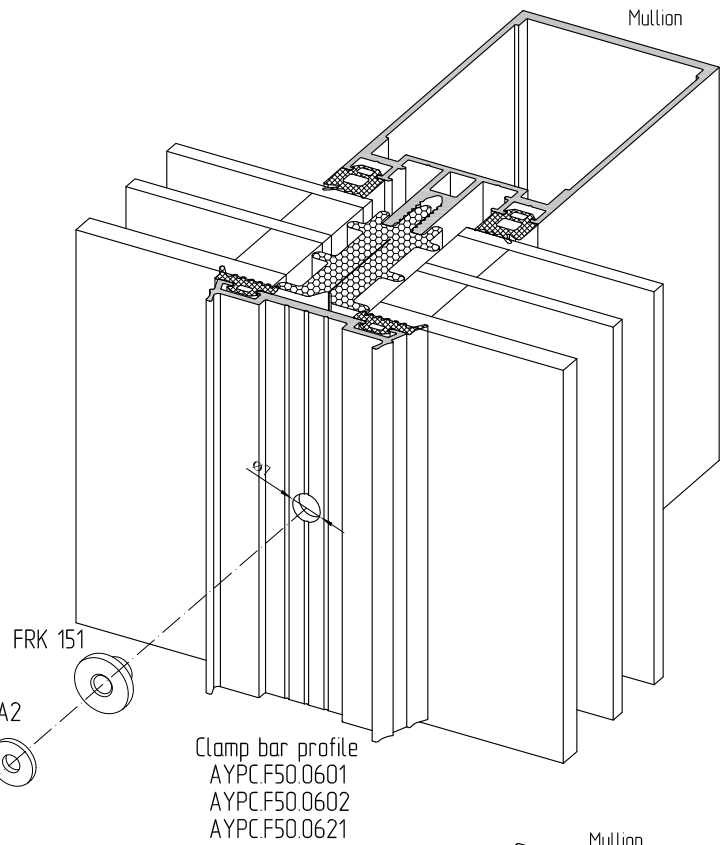

Scheme of wirework installation with help of FRK 124 rubber gasket

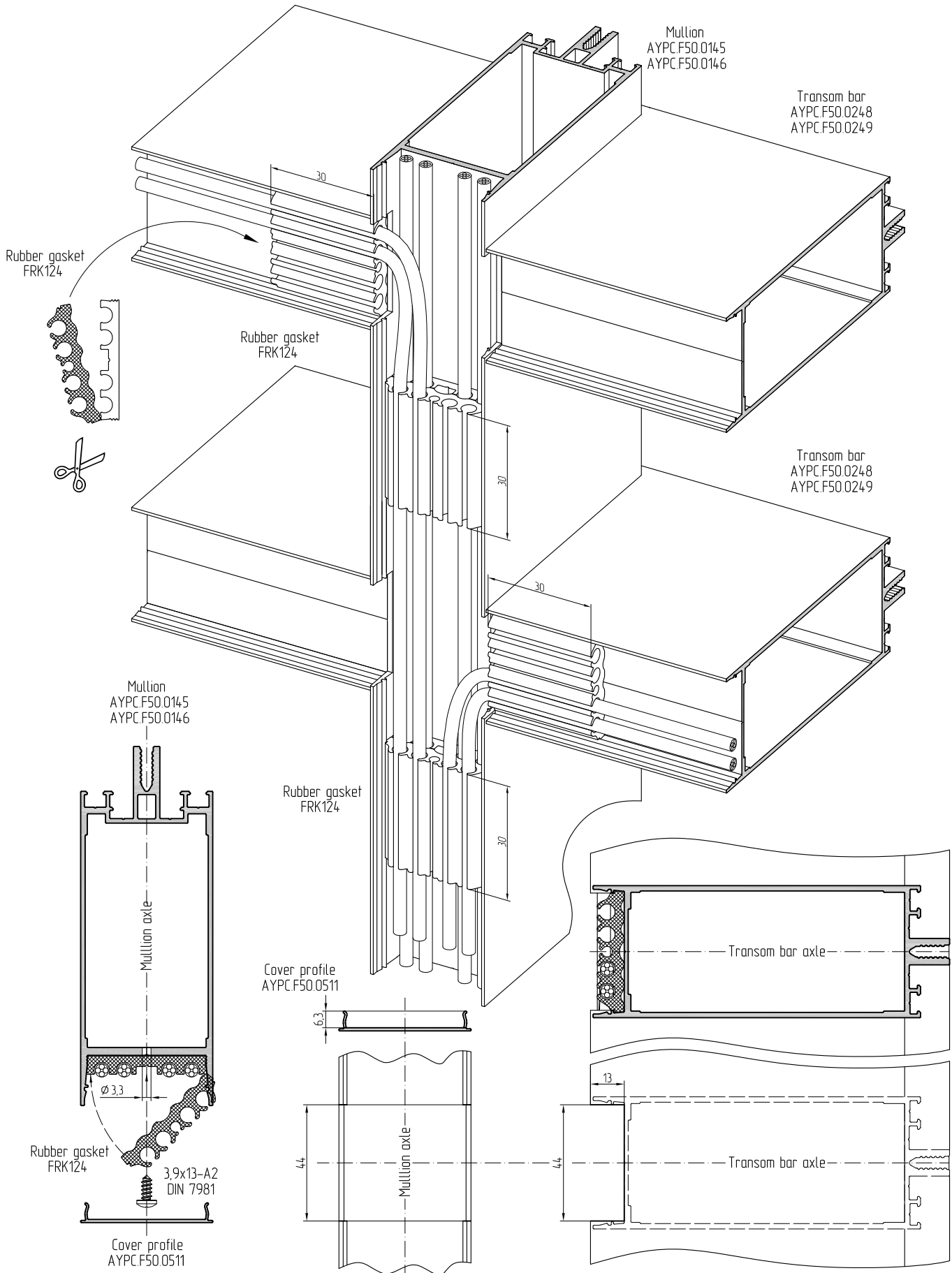

Scheme of wirework installation with help of FRK 125 rubber gasket

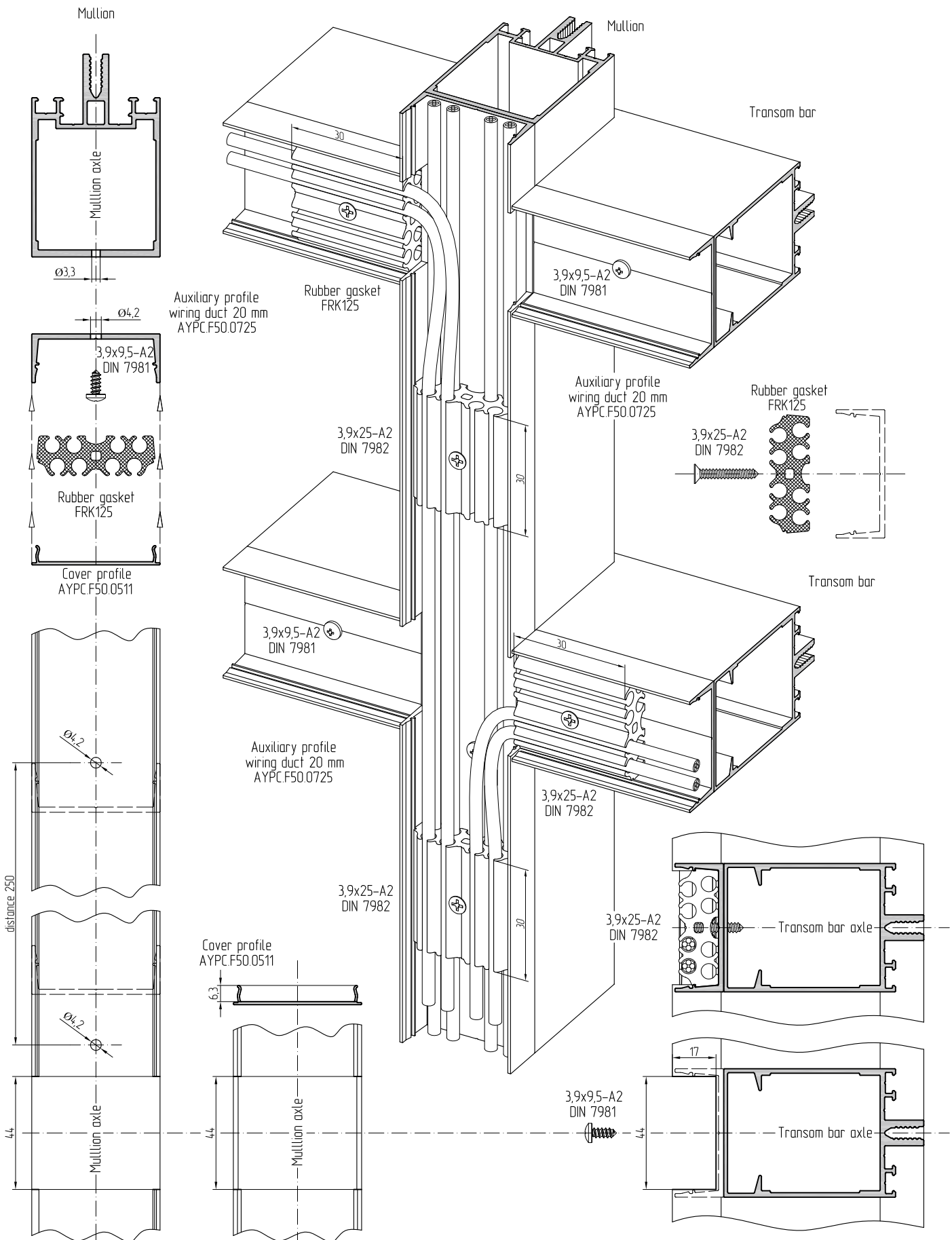

Application of aluminium butyl tape

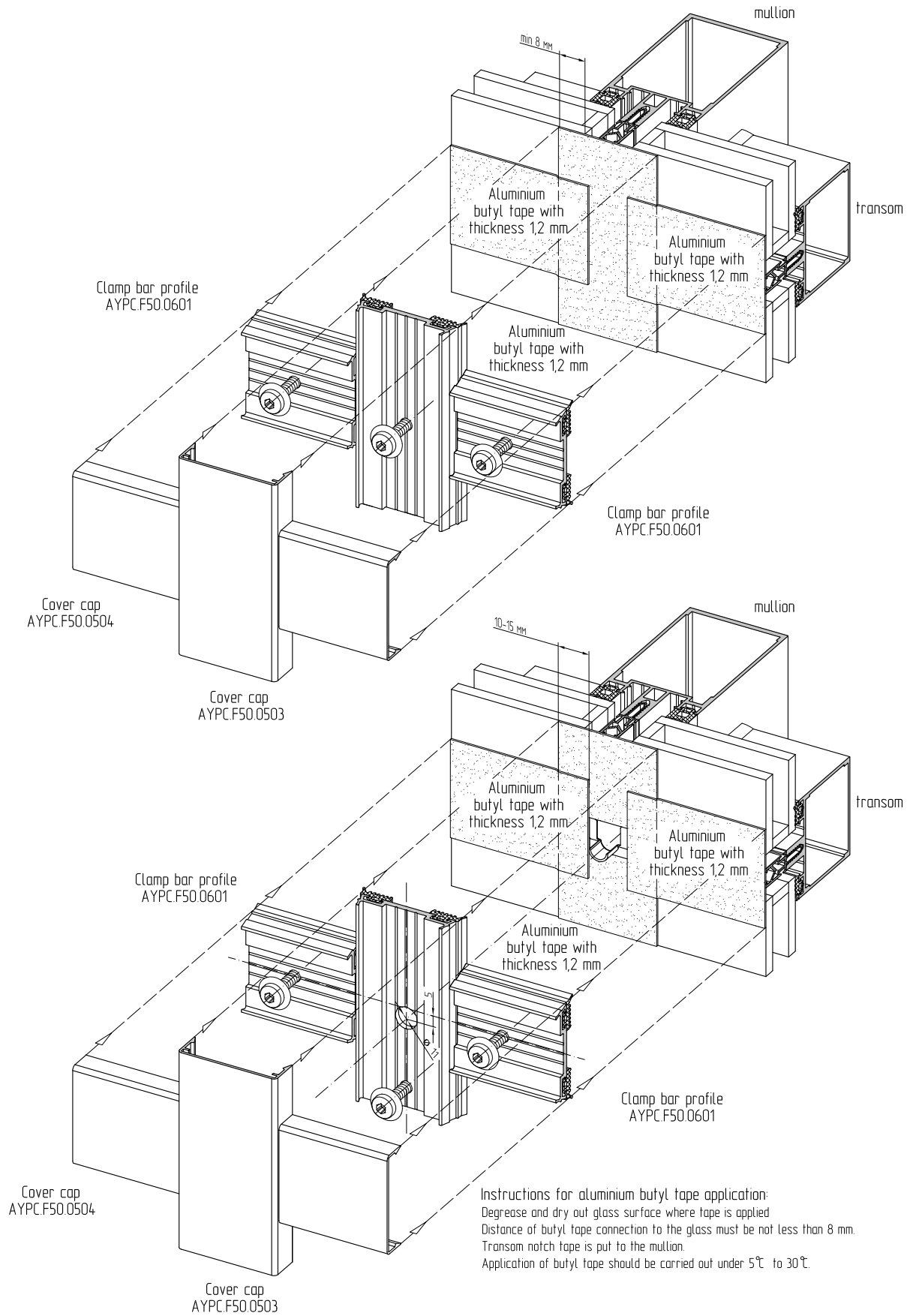

Application of aluminium butyl tape

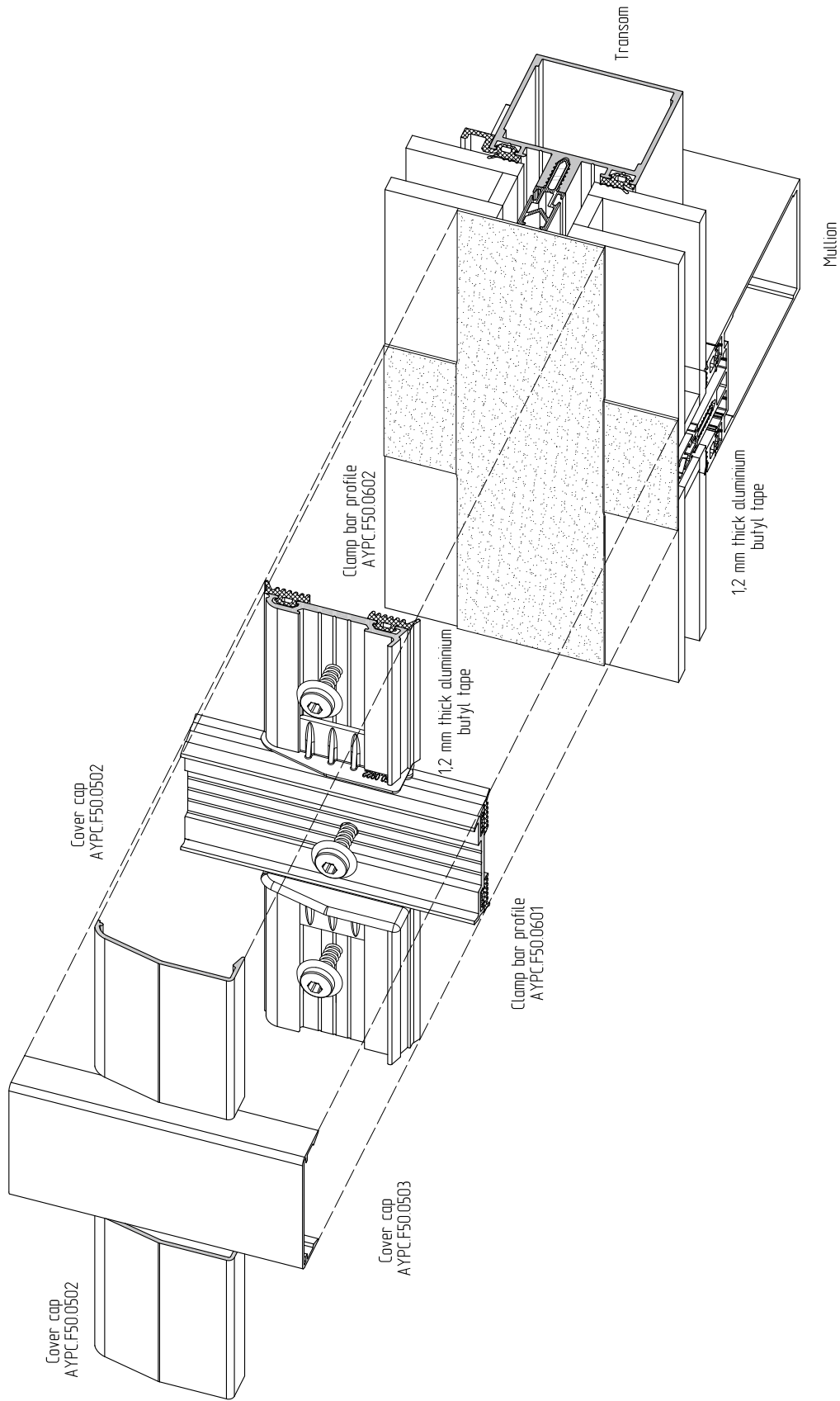

Instructions for aluminium butyl tape application:  
 Degrease and dry out glass surface where tape is applied  
 Distance of butyl tape connection to the glass must be not less than 8 mm.  
 Transom notch tape is put to the mullion.  
 Application of butyl tape should be carried out under 5°C to 30°C.

Mounting of aluminium inserts at the connection of cover caps AYPC.F50.0503 and AYPC.F50.0505

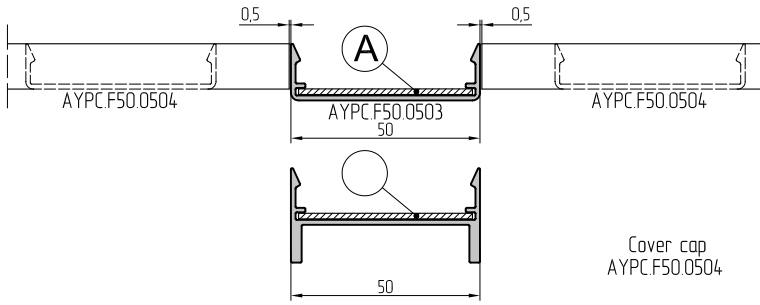

Cover cap  
AYPC.F50.0504

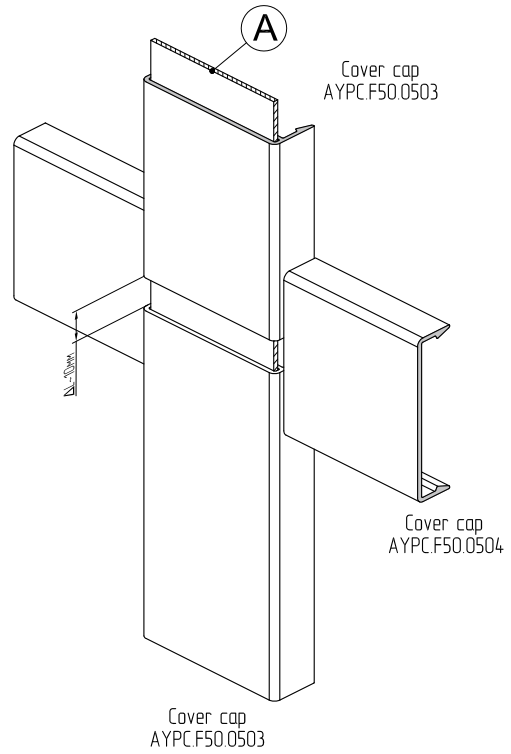

Cover cap  
AYPC.F50.0503

Cover cap  
AYPC.F50.0504

Cover cap  
AYPC.F50.0503

Inserts are made of 1,5 mm thick aluminium sheet

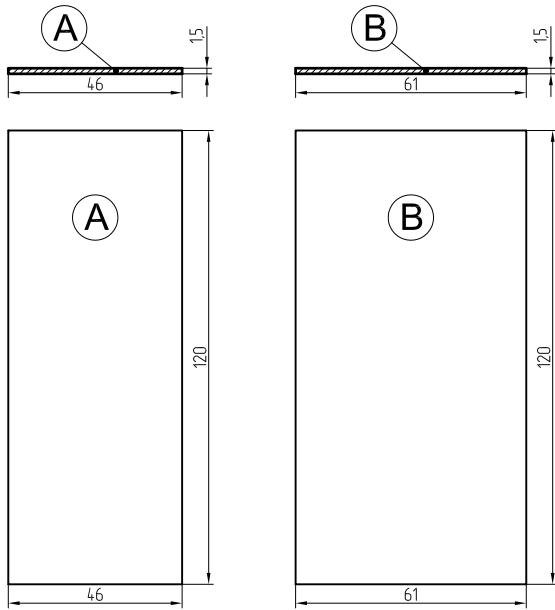

Cover cap  
AYPC.F50.0506

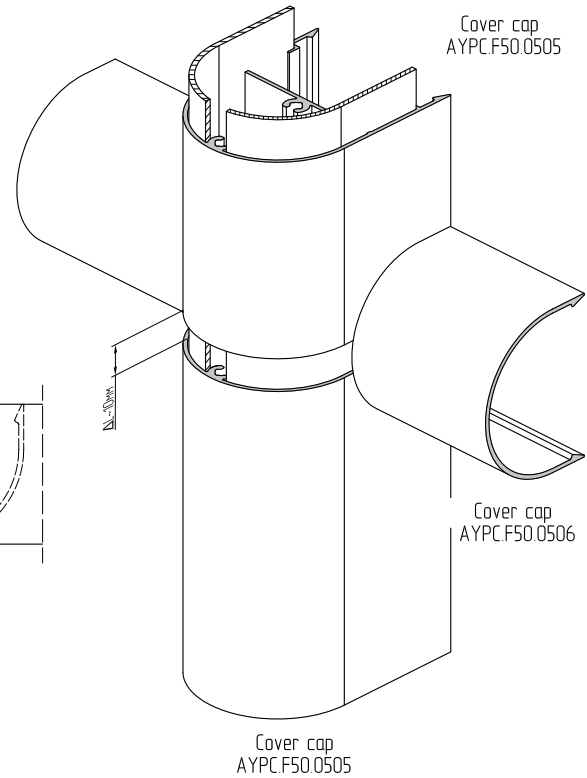

Cover cap  
AYPC.F50.0505

Cover cap  
AYPC.F50.0506

Cover cap  
AYPC.F50.0505

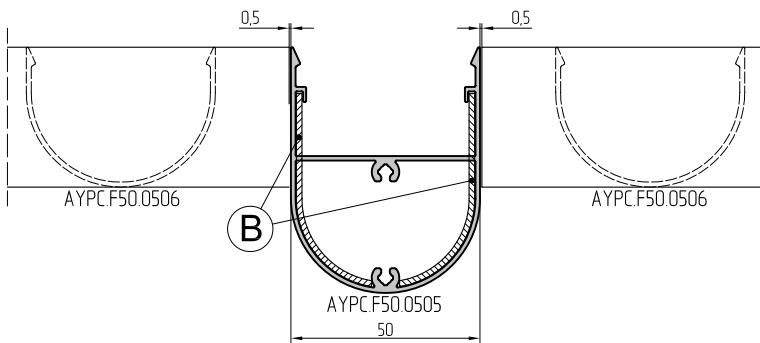

Mounting of edge plugs and aluminium inserts at the connection of cover caps AYPC.F50.0505

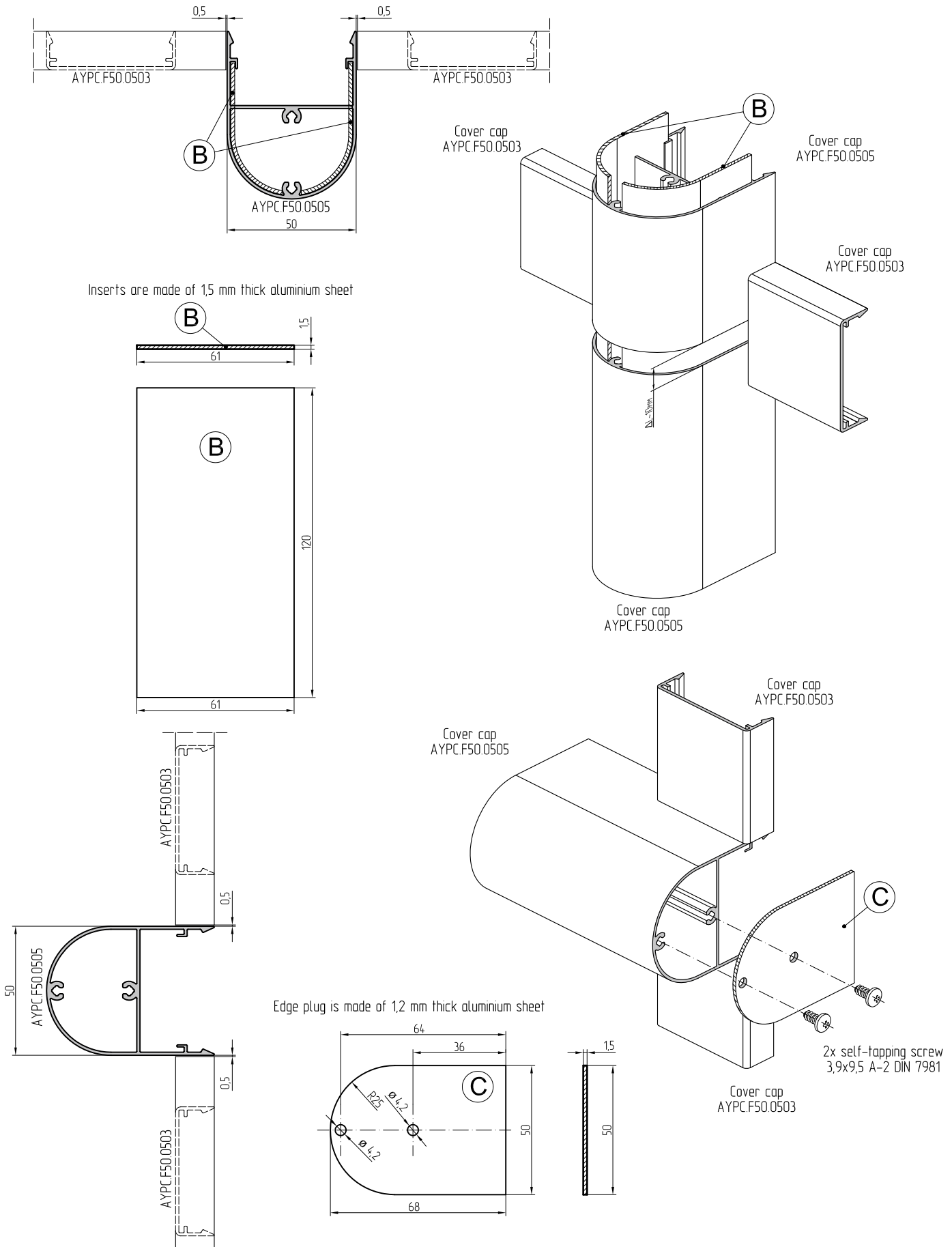

Mounting of edge plugs and aluminium inserts at the connection of cover caps AYPC.F50.0507

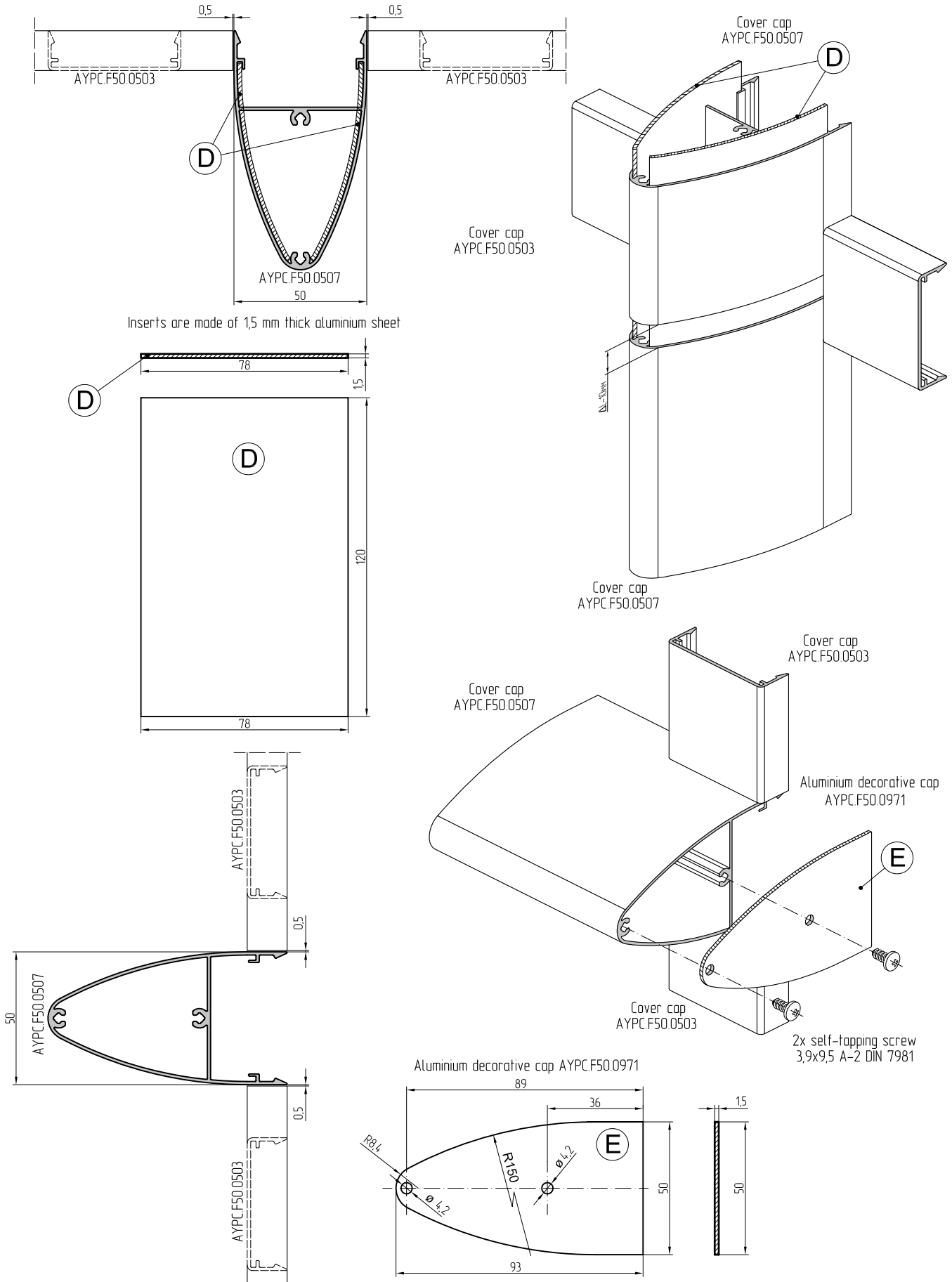



Mounting of edge plugs and aluminium inserts at the connection of cover caps AYPC.F50.0520

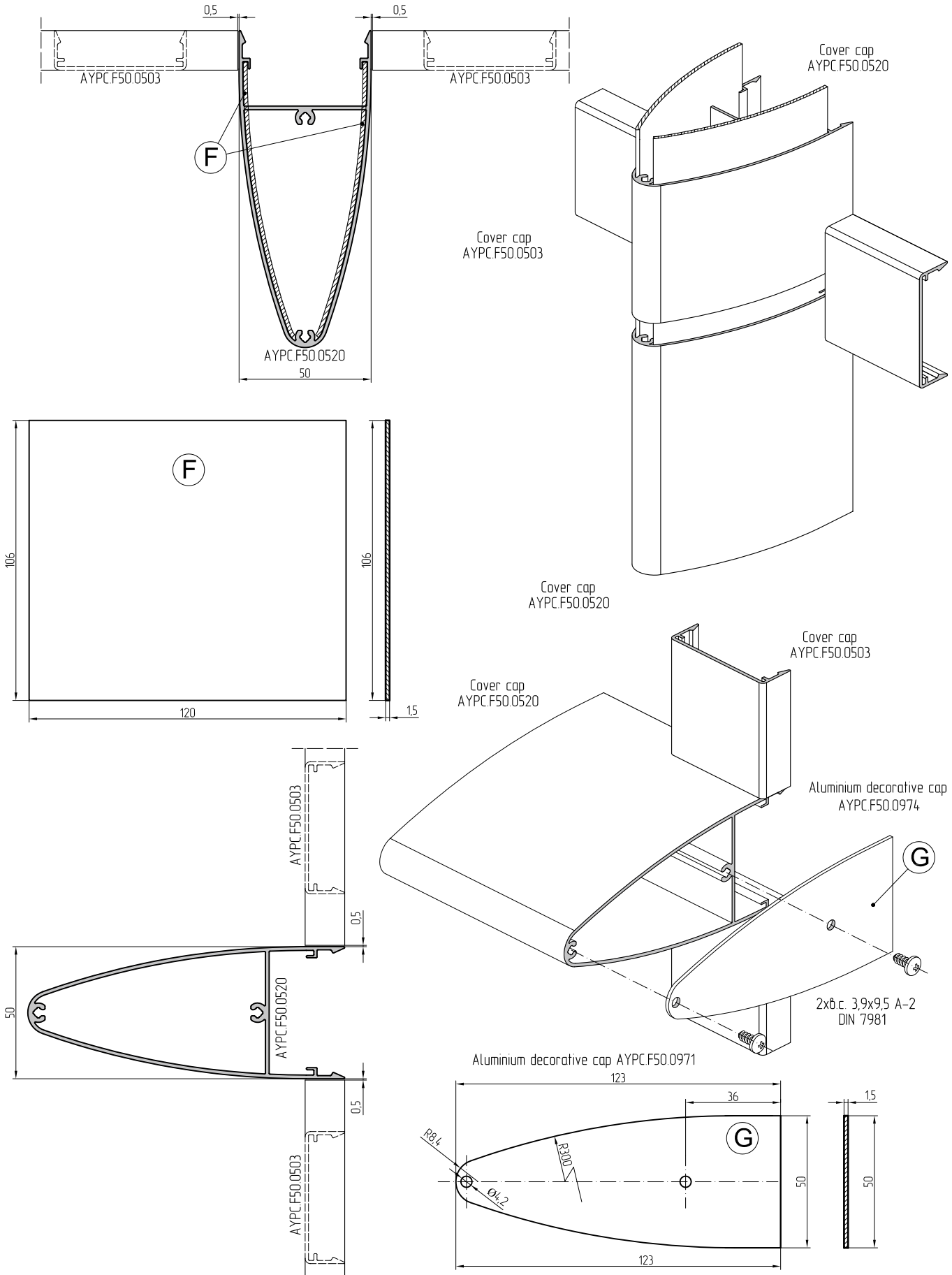



Mounting of brackets at the connection of cover caps AYPC.F50.0508 and AYPC.F50.0521

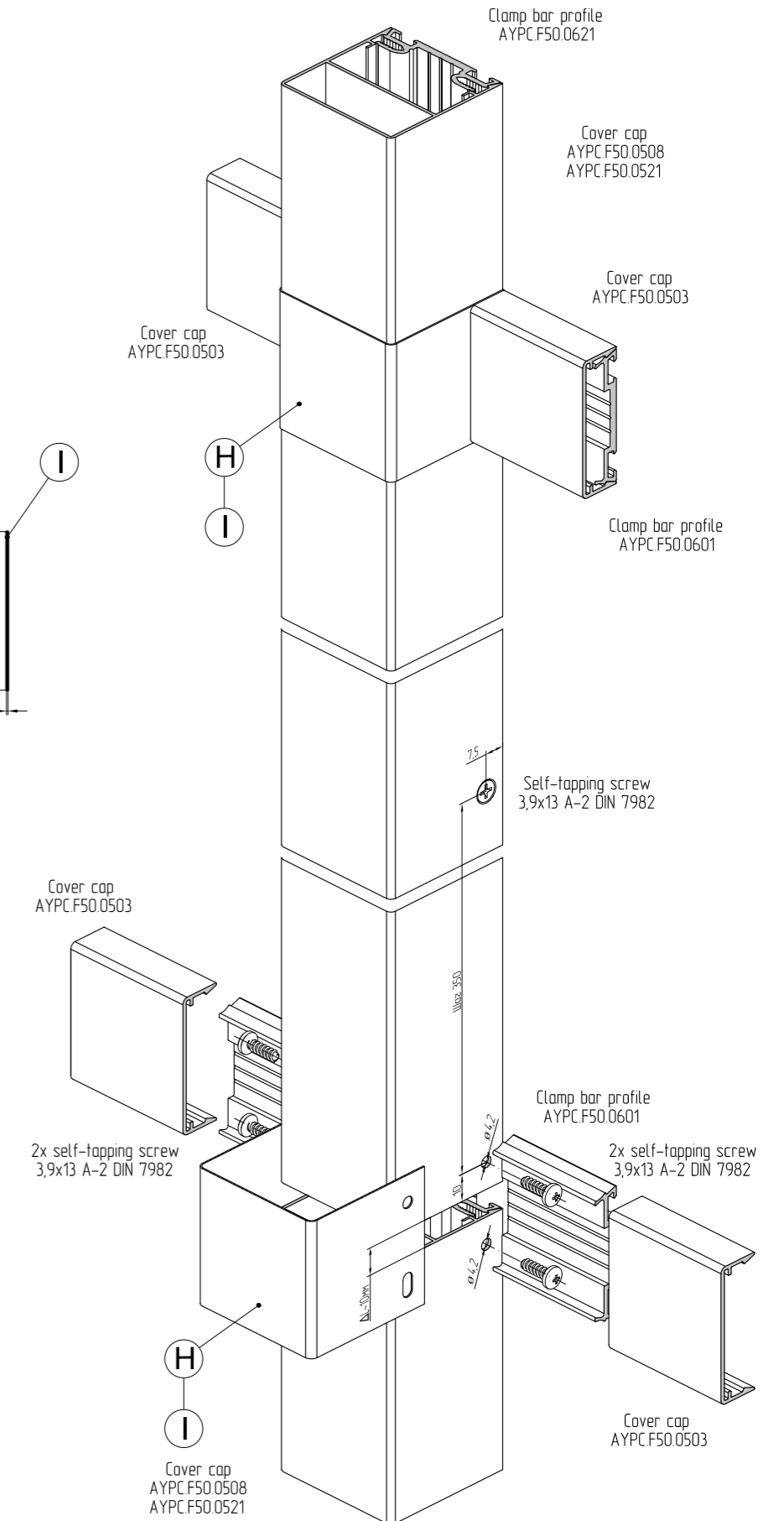
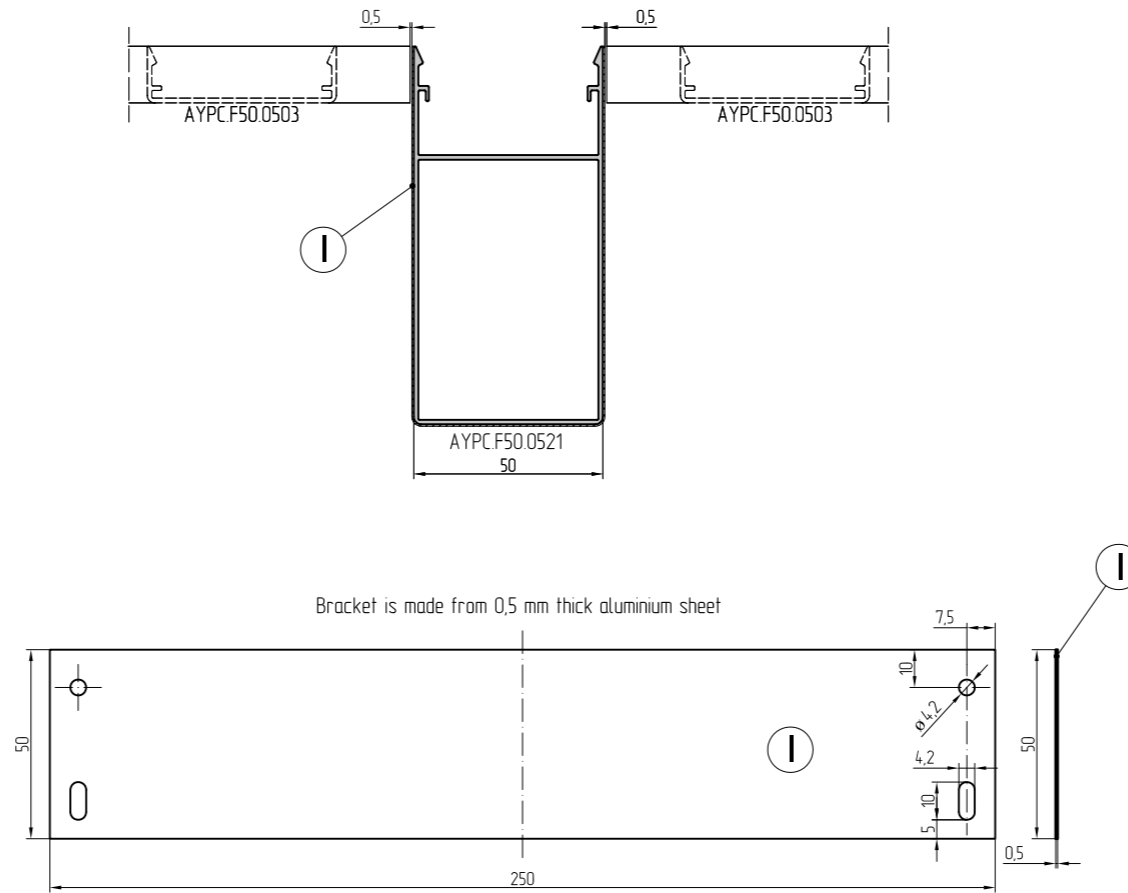
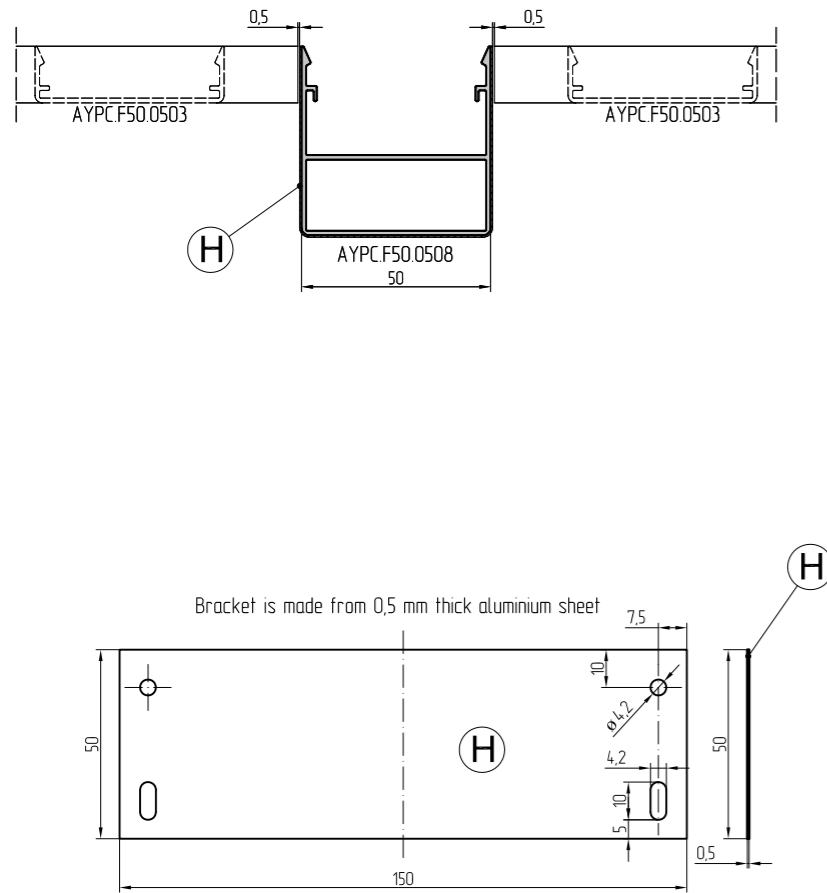

Mounting of brackets at the connection of cover caps AYPC.F50.0507

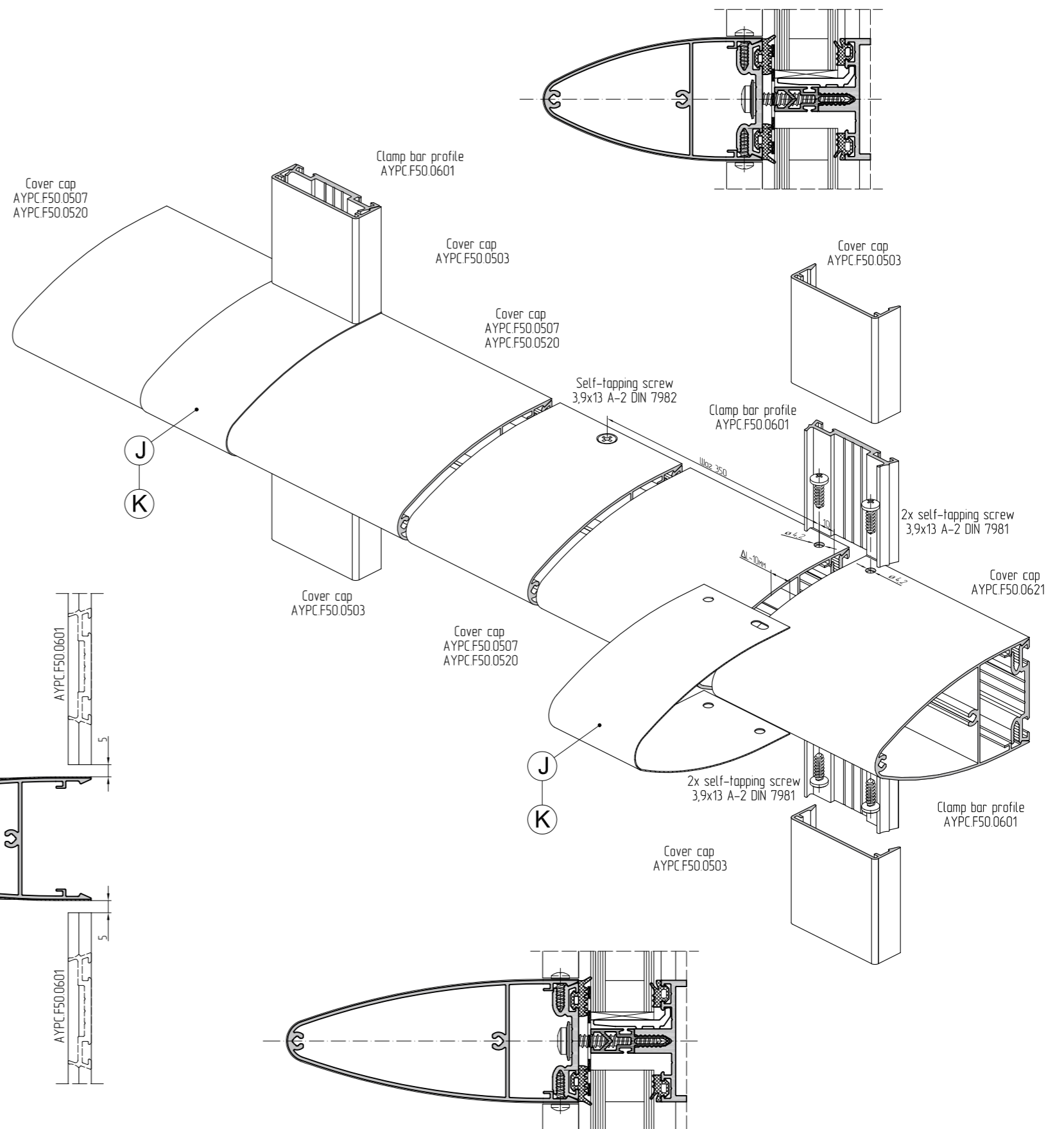
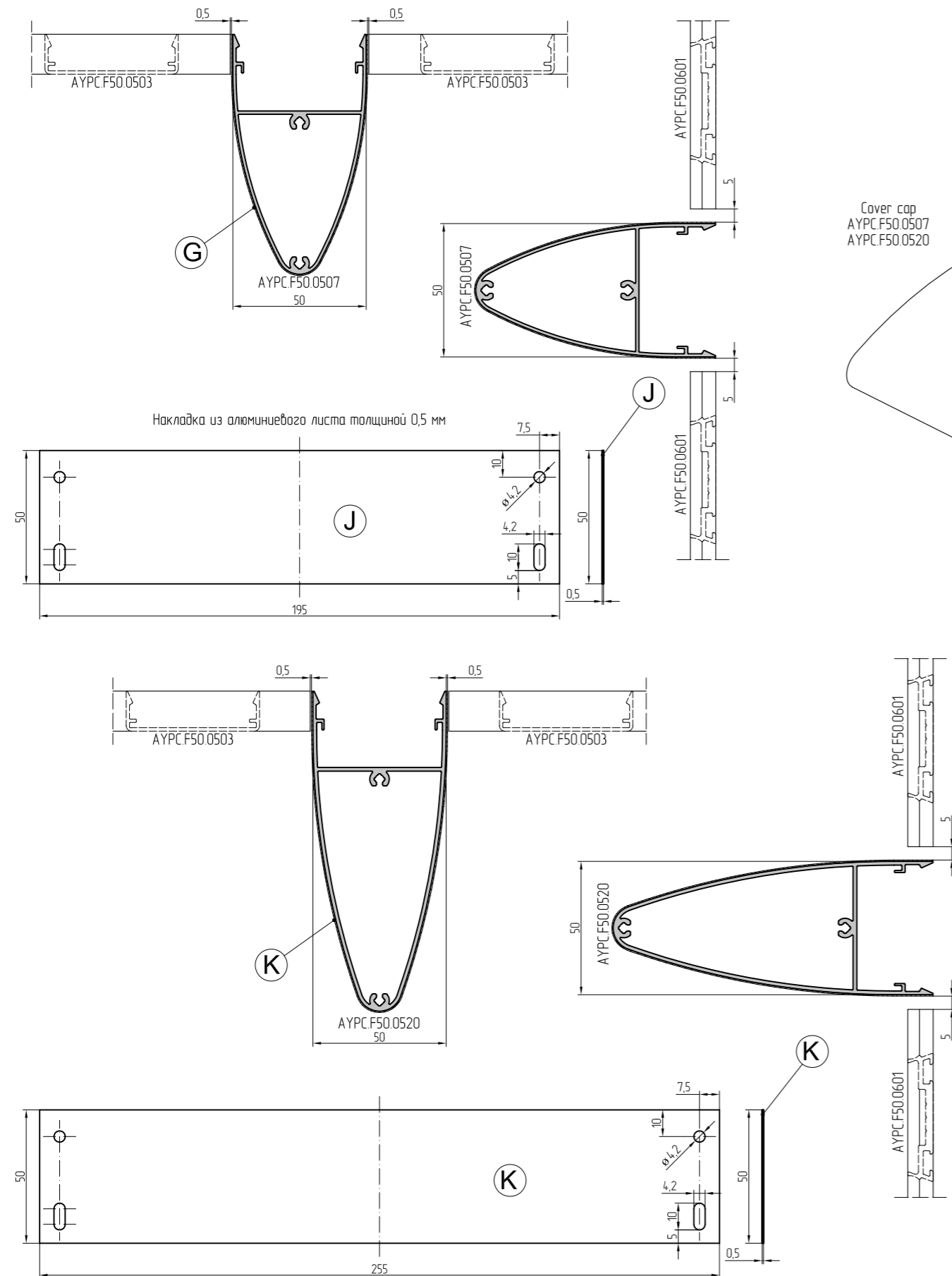



Mounting of brackets at the connection of cover caps AYPC.F50.0510

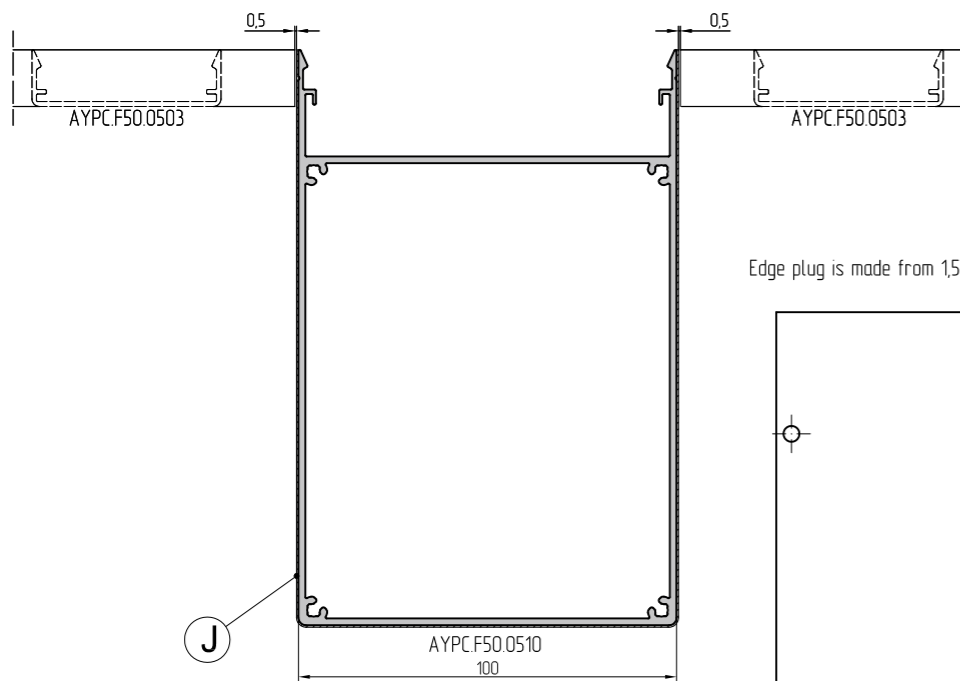

Bracket is made from 0,5 mm thick aluminium sheet

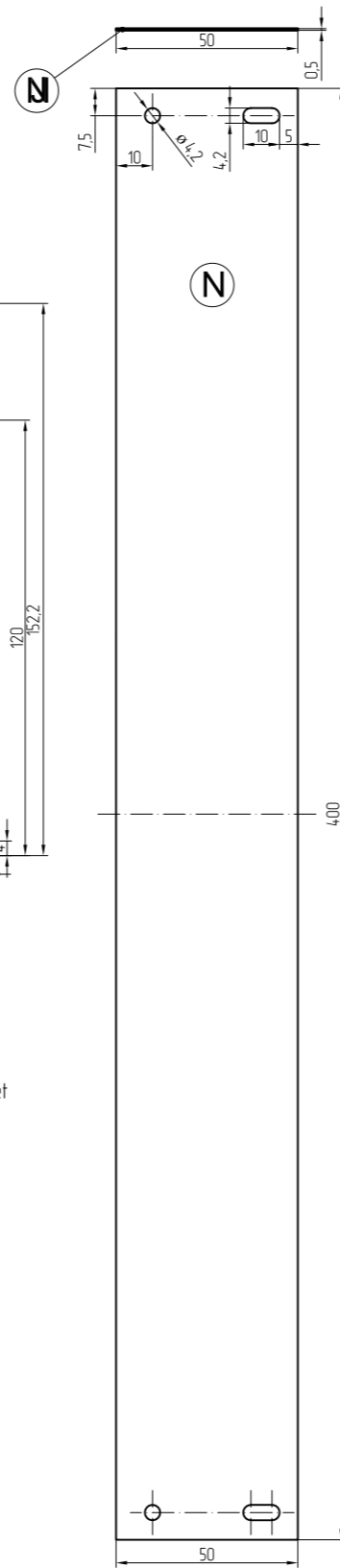

Edge plug is made from 1,5 mm thick aluminium sheet

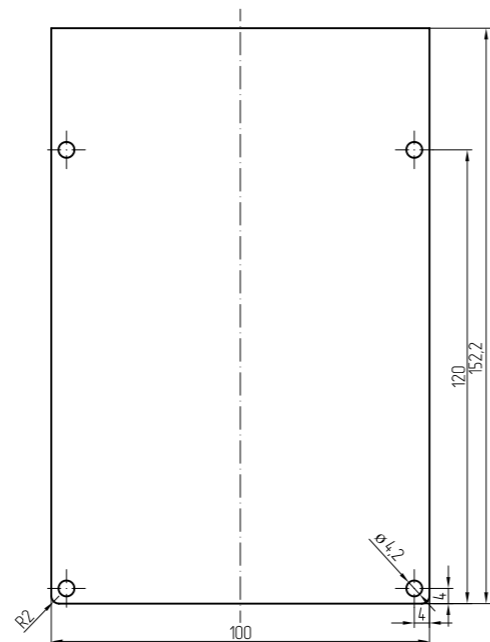

Junction is made from 2,5 mm thick aluminium sheet

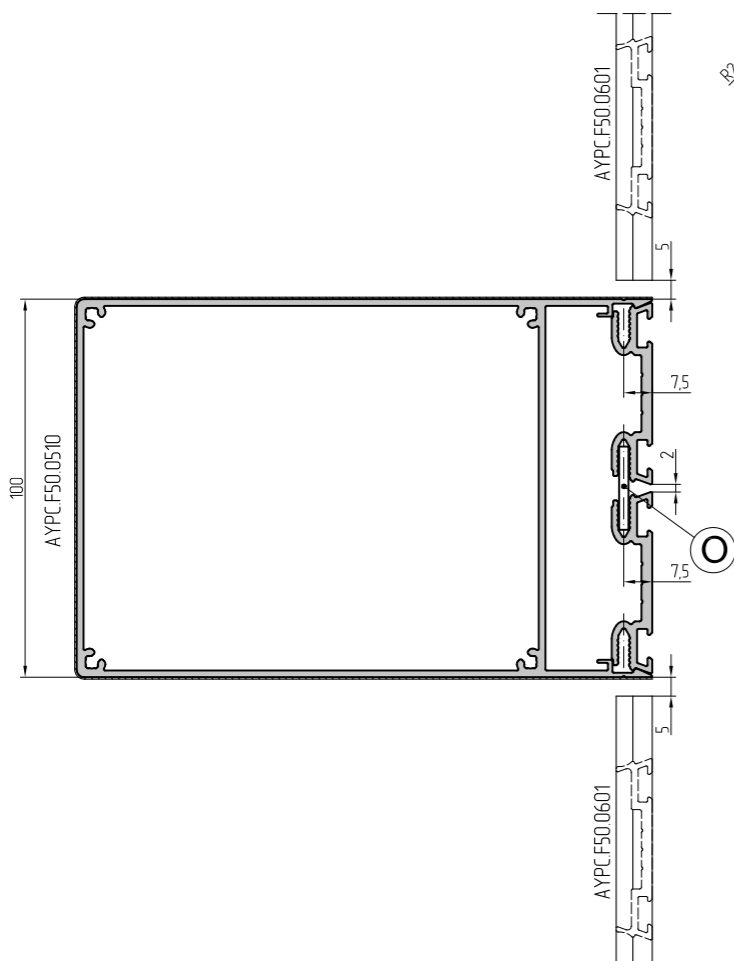
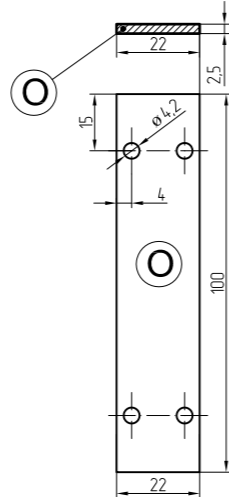

Clamp bar profile AYPC.F50.0621

Clamp bar profile AYPC.F50.0621

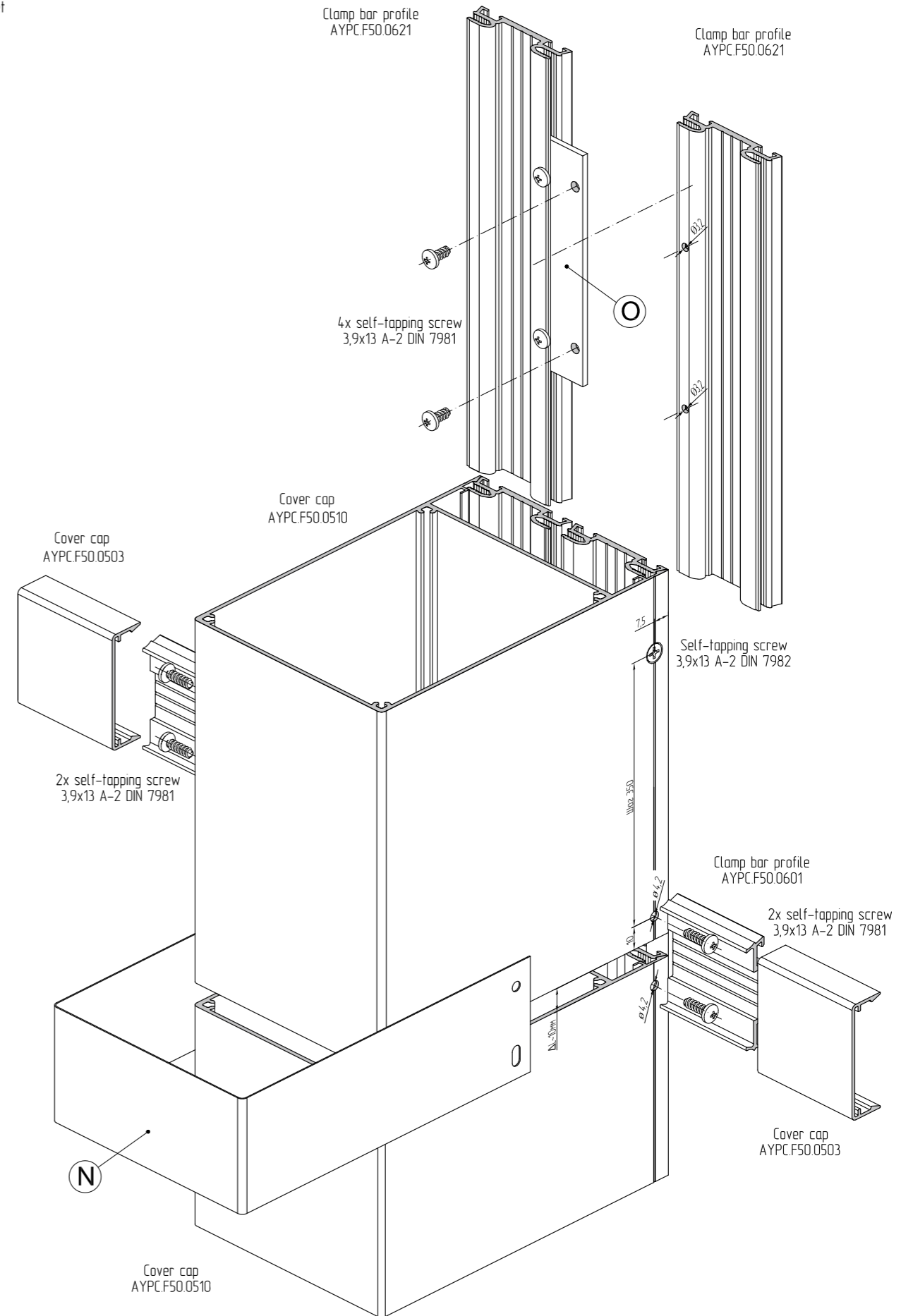



**ALUFACH ALT F50**  
CURTAIN WALL  
SYSTEM

# EXAMPLE OF STANDARD CONSTRUCTION CALCULATION

12





Calculation of standard curtain wall construction. Notch connection of mullions and transoms

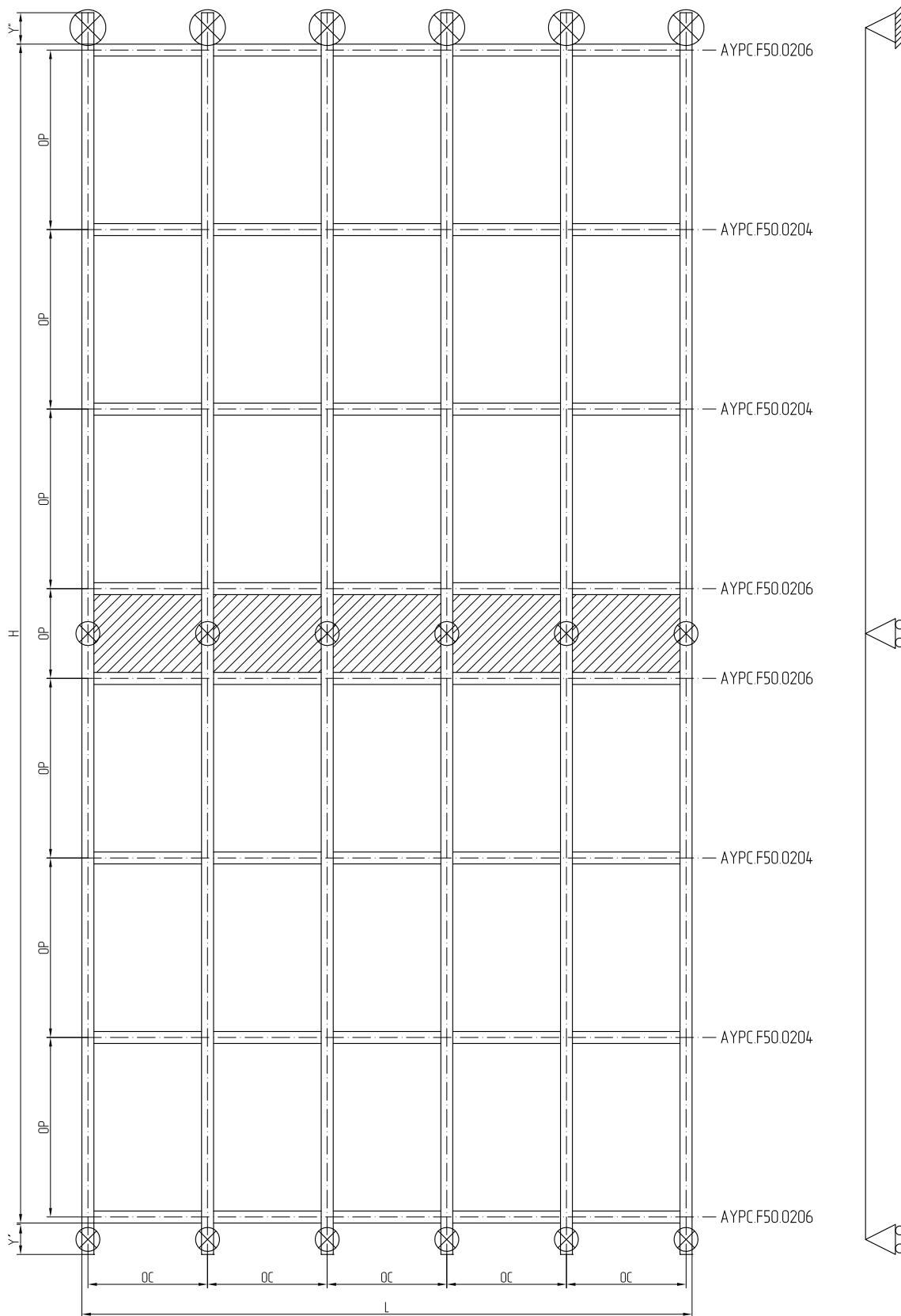

**Calculation of standard curtain wall construction. Notch connection of mullions and transoms**
**ALuminium profiles**

Article	Name	Cutting scheme	Quantity
AYPC.F50.0103	Mullion 80 mm	H+Y+Y"	6
AYPC.F50.0204	Transom 45 mm	OC-20	20
AYPC.F50.0206	Transom 85 mm	OC-20	20
AYPC.F50.0601	Clamp bar profile 9,5 mm for mullions	H	6
AYPC.F50.0601	Clamp bar profile 9,5 mm for transoms	OC-55	40
AYPC.F50.0503	Cover cap for mullions	H	6
AYPC.F50.0504	Cover cap profile for transoms	OC-51	40

**PVC (PVC-U-HI) profiles**

Article	Name	Cutting scheme	Quantity
AYPC.F50.0905	Thermal break profile 18 mm for mullions	H	6
AYPC.F50.0905	Thermal break profile 18 mm for transoms 45 mm	OC-12	40
AYPC.F50.0902	Distance profile 24 mm for mullions	H   OP-51	2   10
AYPC.F50.0901	Distance profile 18 mm for transoms	OC-20	20

**Gaskets (EPDM)**

Article	Name	Cutting scheme	Quantity
FRK17	Rubber gasket 9 mm for mullions and distance profiles 24 mm and 18 mm	H+2%   (OC-20)+2%	12   10
FRK14	Rubber gasket 3 mm for transoms	(OC-20)+2%	60
FRK15	Rubber gasket 5 mm for distance profile 24 mm	(OP-51)+2%	10
FRK15	Rubber gasket 5 mm for distance profile 18 mm	(OC-20)+2%	10
FRK24	Rubber gasket 3 mm for clamp bar profile 9,5 mm for mullions	H+2%	12
FRK24	Rubber gasket 3 mm for clamp bar profile 9,5 mm for transoms	(OC-55)+2%	80

**Hardware**

Article	Name	Quantity
AYPC.F50.0945-01	Jet nut 36 mm from profile F50.0405 for transoms 45 mm	40
AYPC.F50.0945-03	Jet nut 63 mm from profile F50.0405 for transoms 85 mm	40
AYPC.F50.0941	Aluminium support plate 100 mm from profile F50.0802, under Glass unit 26 mm	70
100x26x3	Leveling plate under Glass unit 26 mm	70
AYPC.F50.0921	Transom plug	80
AYPC.F50.0923	Drip drain	12
FRK42	Sealing plate	80
AYPC.F50.2901-01	Anchor support (fixing kit)	6
AYPC.F50.2902-01	Wind support (fixing kit)	12
	Self-tapping screw 3,9x13 DIN 7981 for fixing junction element to a mullion	160
	Self-tapping screw 3,9x16 DIN 7981 for fixing transoms to a mullion	160
	Self-tapping screw 5,5x38-A4 DIN 7981 for fixing mullion and transom clamp bars	(H/250)6+(OC/250)80
	Washer with rubber gasket under self-tapping screw 5,5x38-A4 DIN 7981	(H/250)6+(OC/250)80

**Glazing**

Name	Infill unit dimensions	Quantity
Glass unit 26 mm (6-16-4)	(OP-24)x(OC-24)	30
Hardened enamelled glass 6 mm	(OP-24)x(OC-24)	5
1,5 mm thick aluminium sheet	(OP-52)x(OC-52)	5
Waterproofing vapour seal membrane	(OP)x(OC)	5
Silicate cotton	(OP-50)x(OC-50)	5



**ALUFACH** ALTF50  
CURTAIN WALL  
SYSTEM

# PROFILES TREATMENT



Notch connection of mullions and transoms without mounting plastic edge plugs

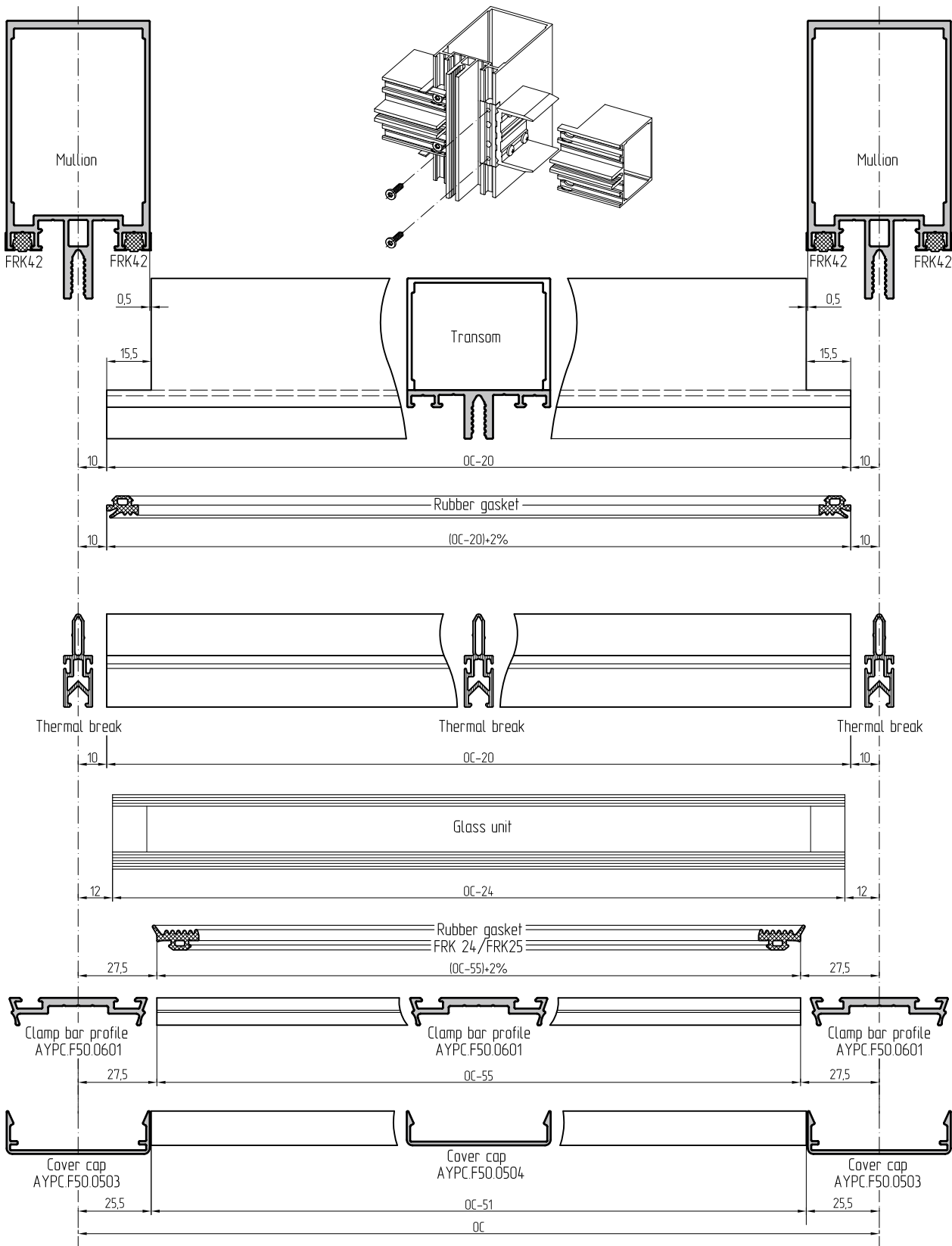

Notch connection of mullions and transoms with mounting plastic edge plugs AYPC.F50.0921, AYPC.F50.0921-01, AYPC.F50.0921-02

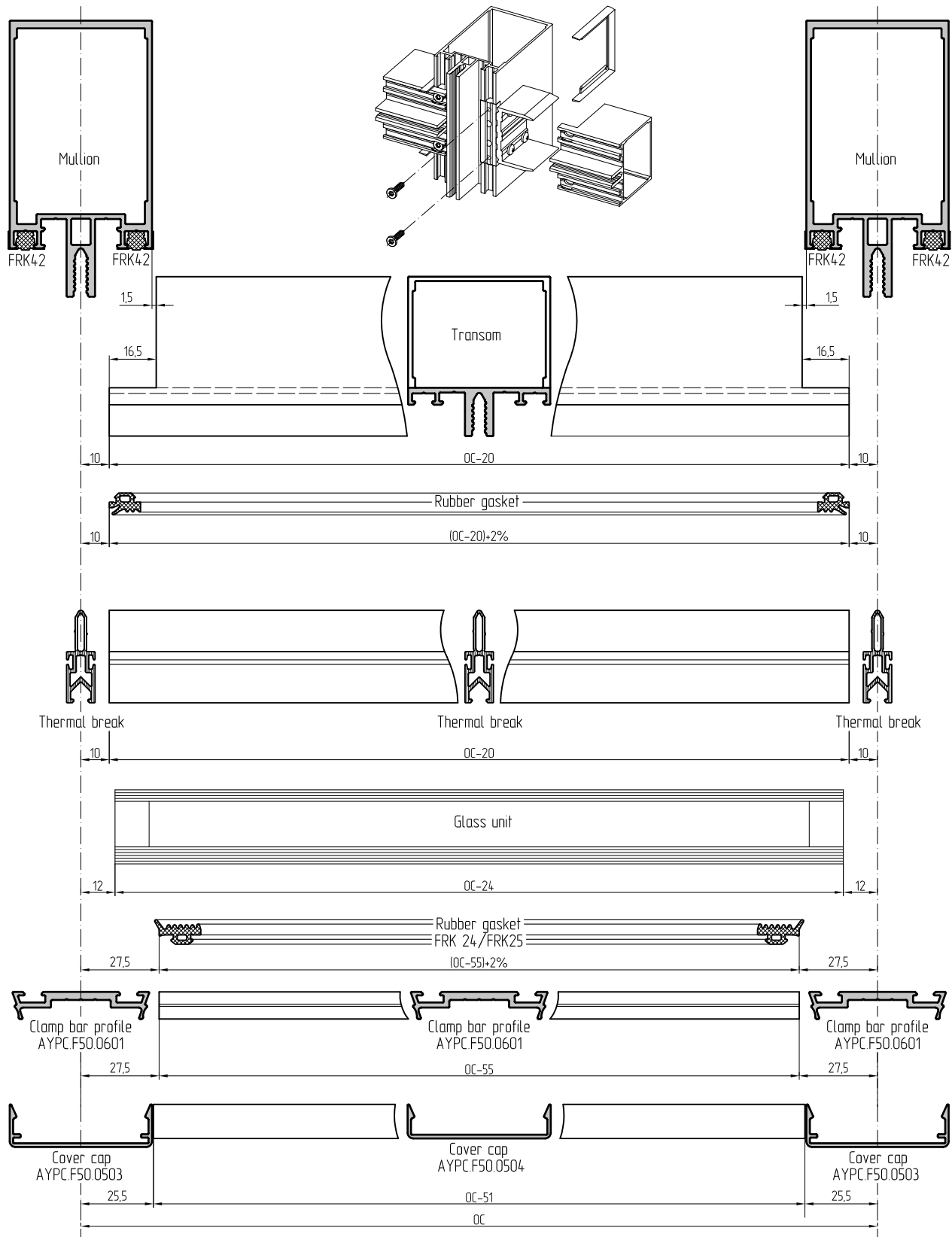

Notch connection of Mullions and transoms with mounting plastic edge plugs AYPC.F50.0921, AYPC.F50.0921-01

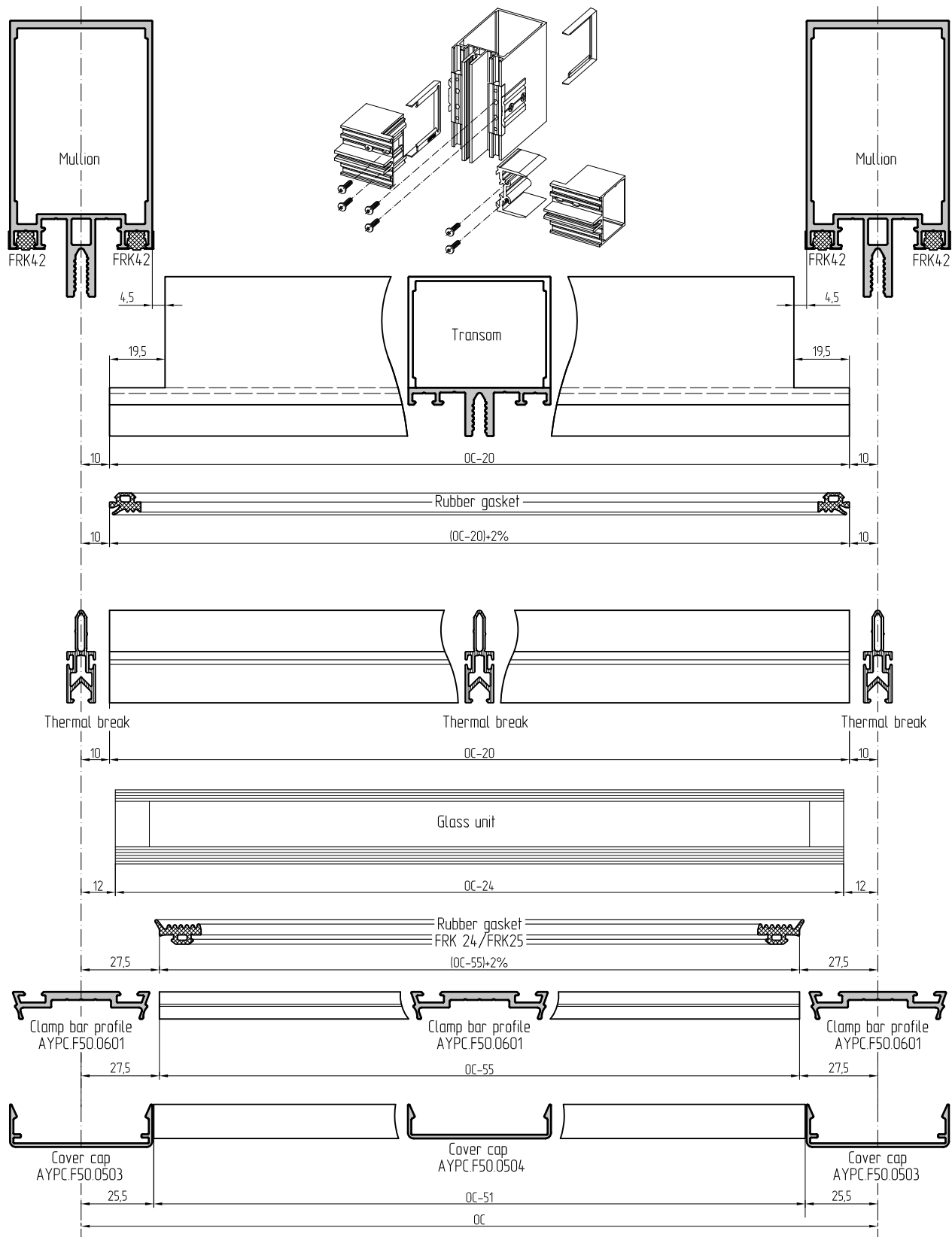

Notch connection of mullions and transoms at the opaque part of facade without mounting plastic edge plugs

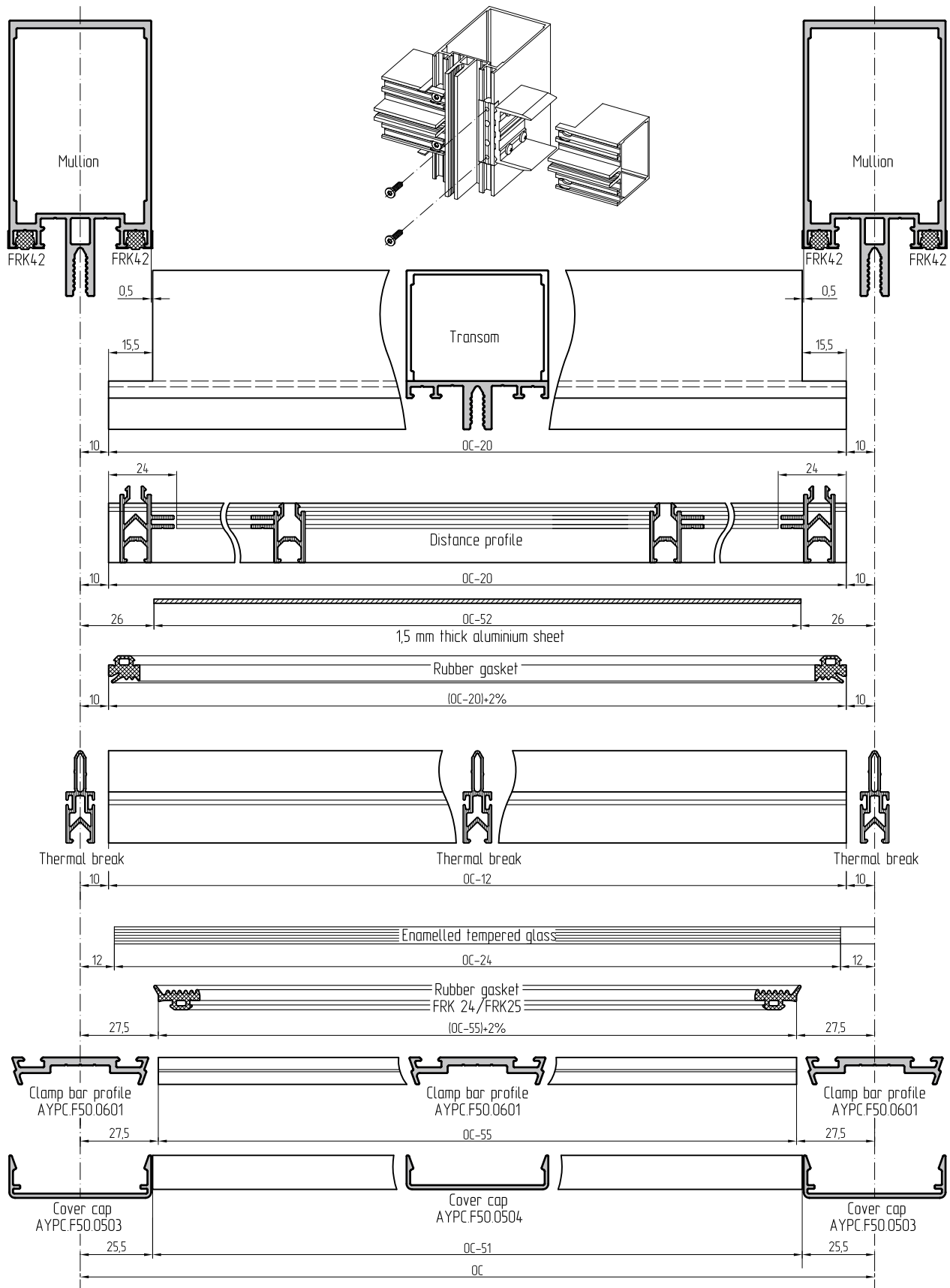



Notch connection of mullions and transoms at the opaque part of facade

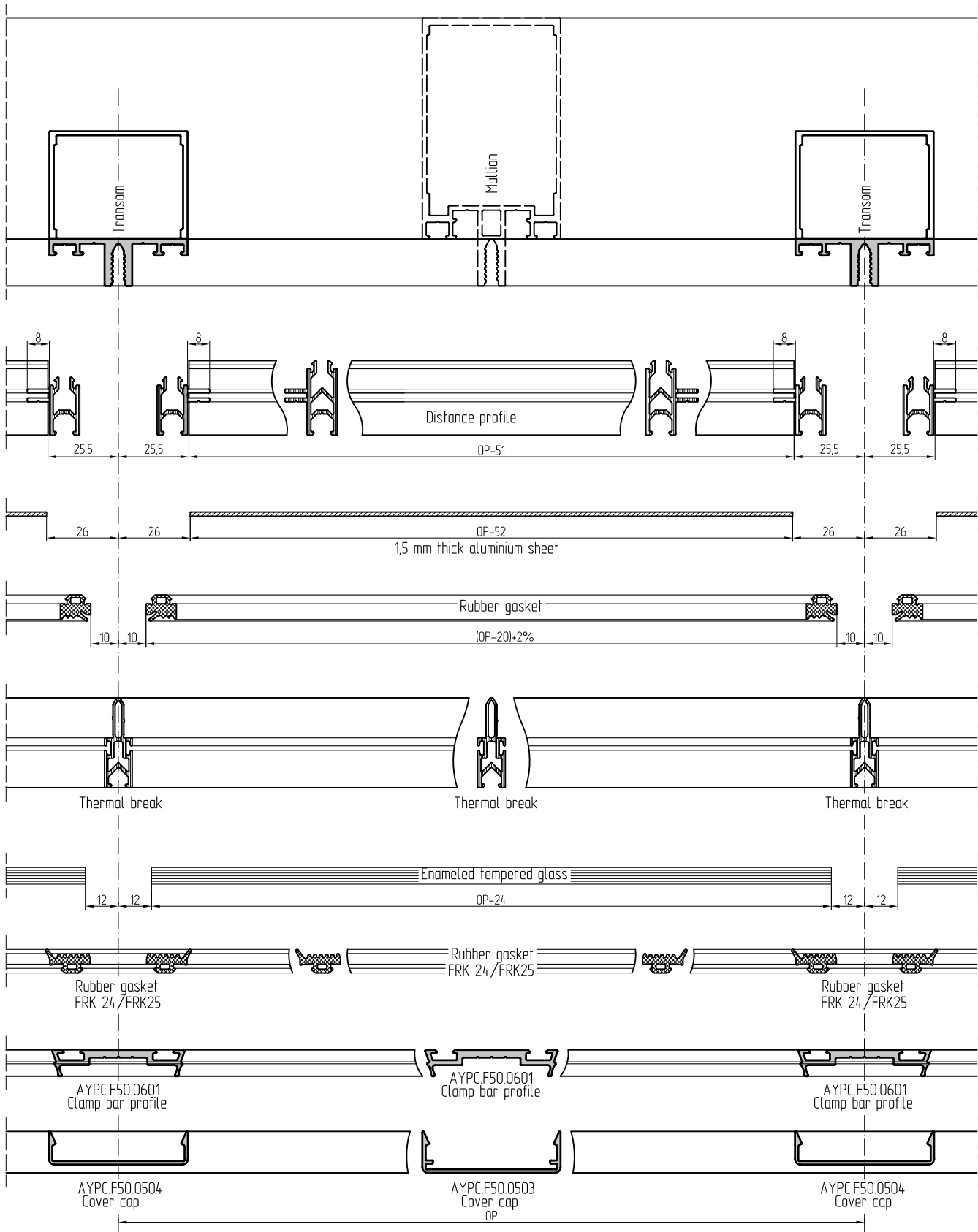

Shaped notch connection of mullions and transoms without mounting plastic edge plugs

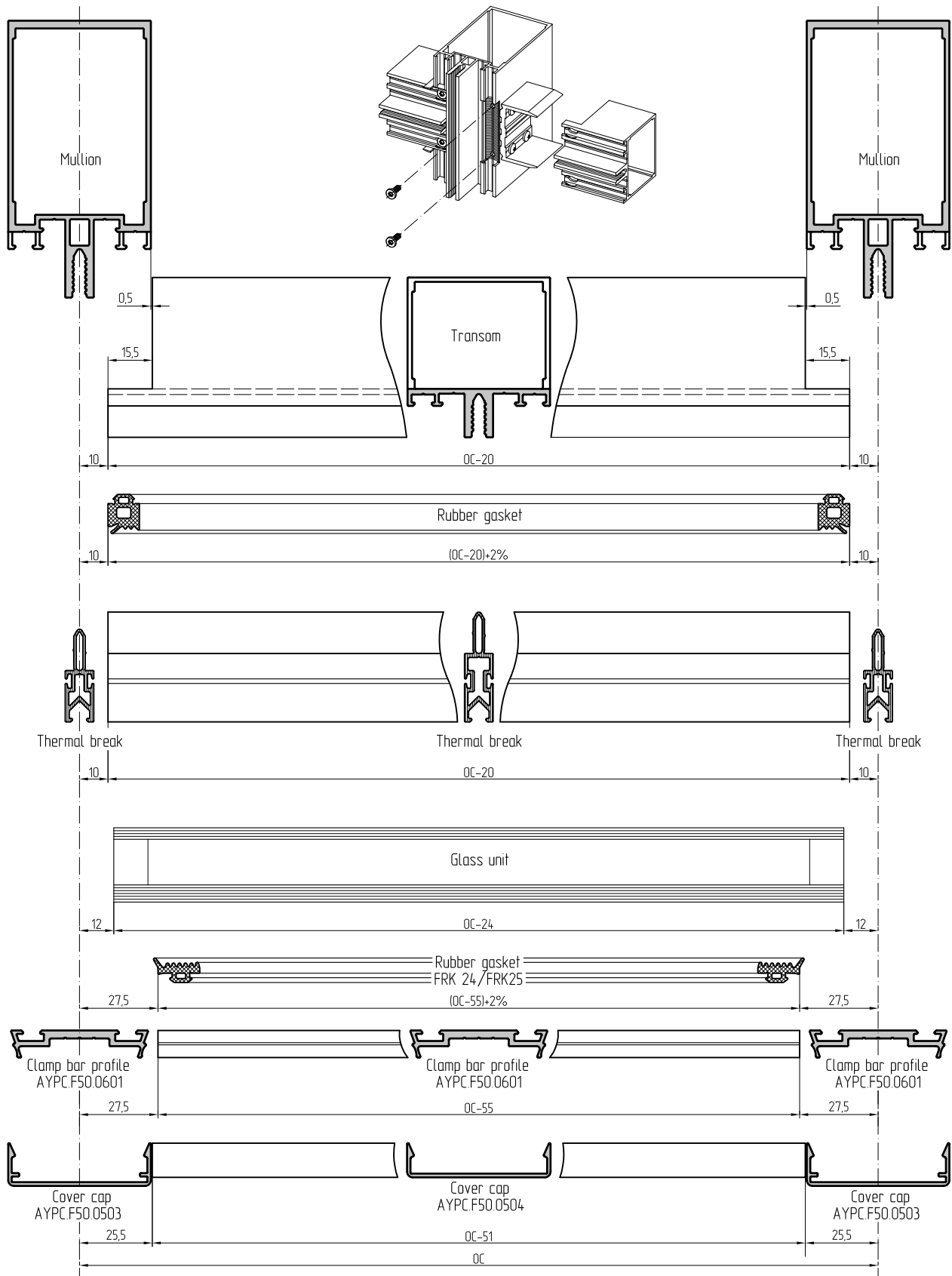

Shaped notch connection of mullions and transoms with mounting plastic edge plugs AYPC.F50.0921, AYPC.F50.0921-01  
AYPC.F50.0921-02

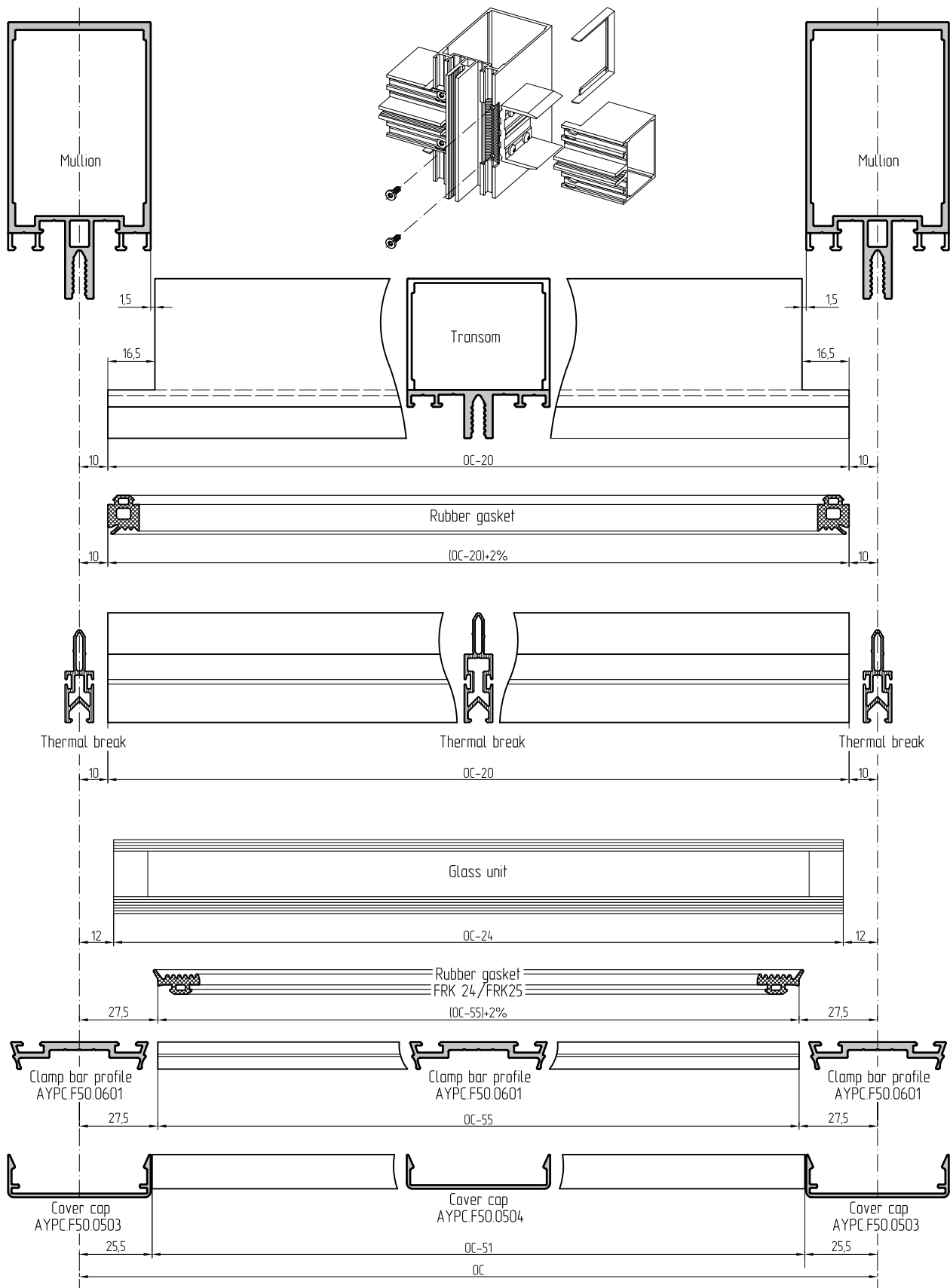

Shaped notch connection of mullions and transoms with mounting plastic edge plugs AYPC.F50.0921, AYPC.F50.0921-01

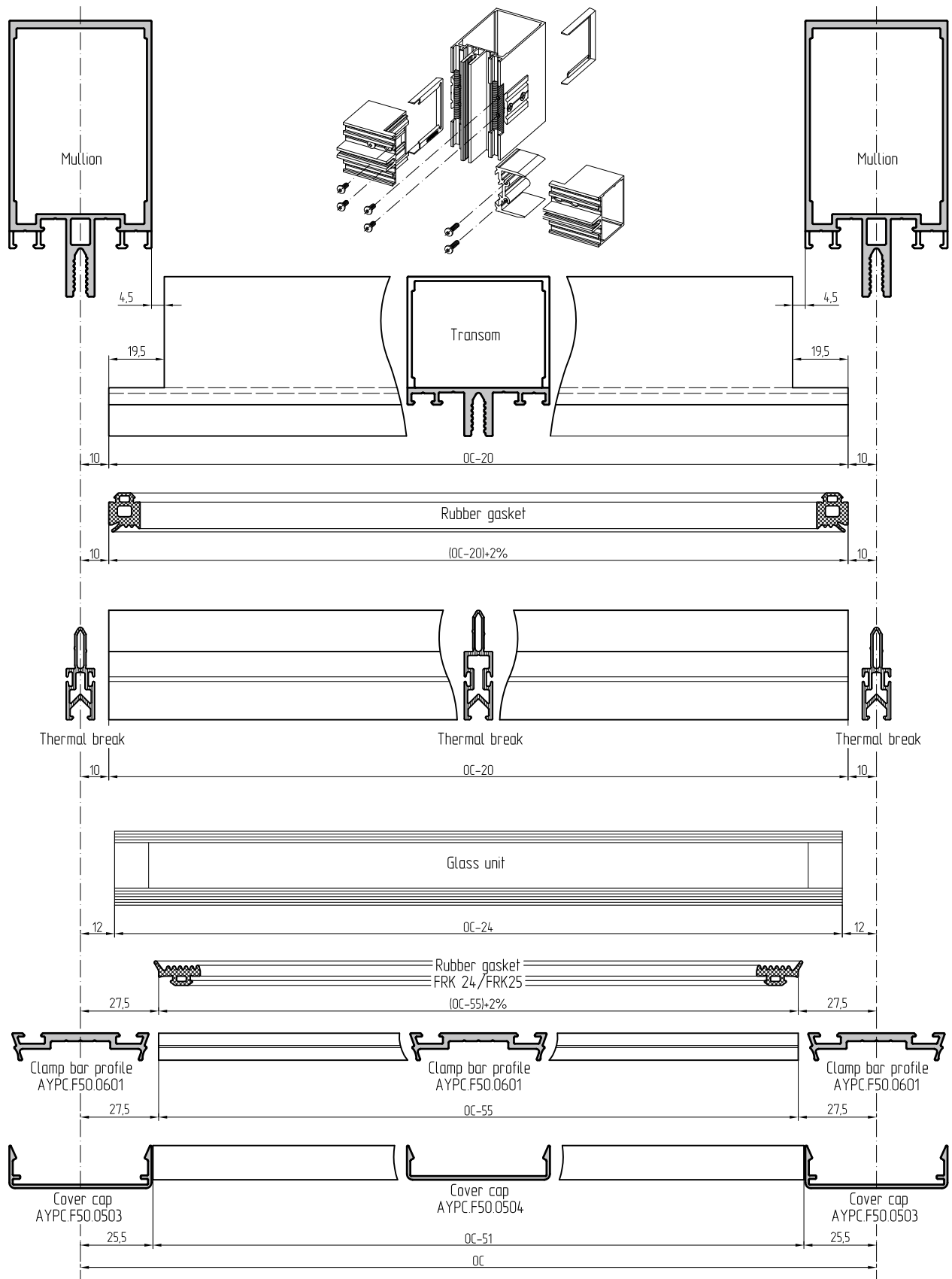

Shaped notch connection of mullions and transoms at the opaque part of facade without mounting plastic edge plugs

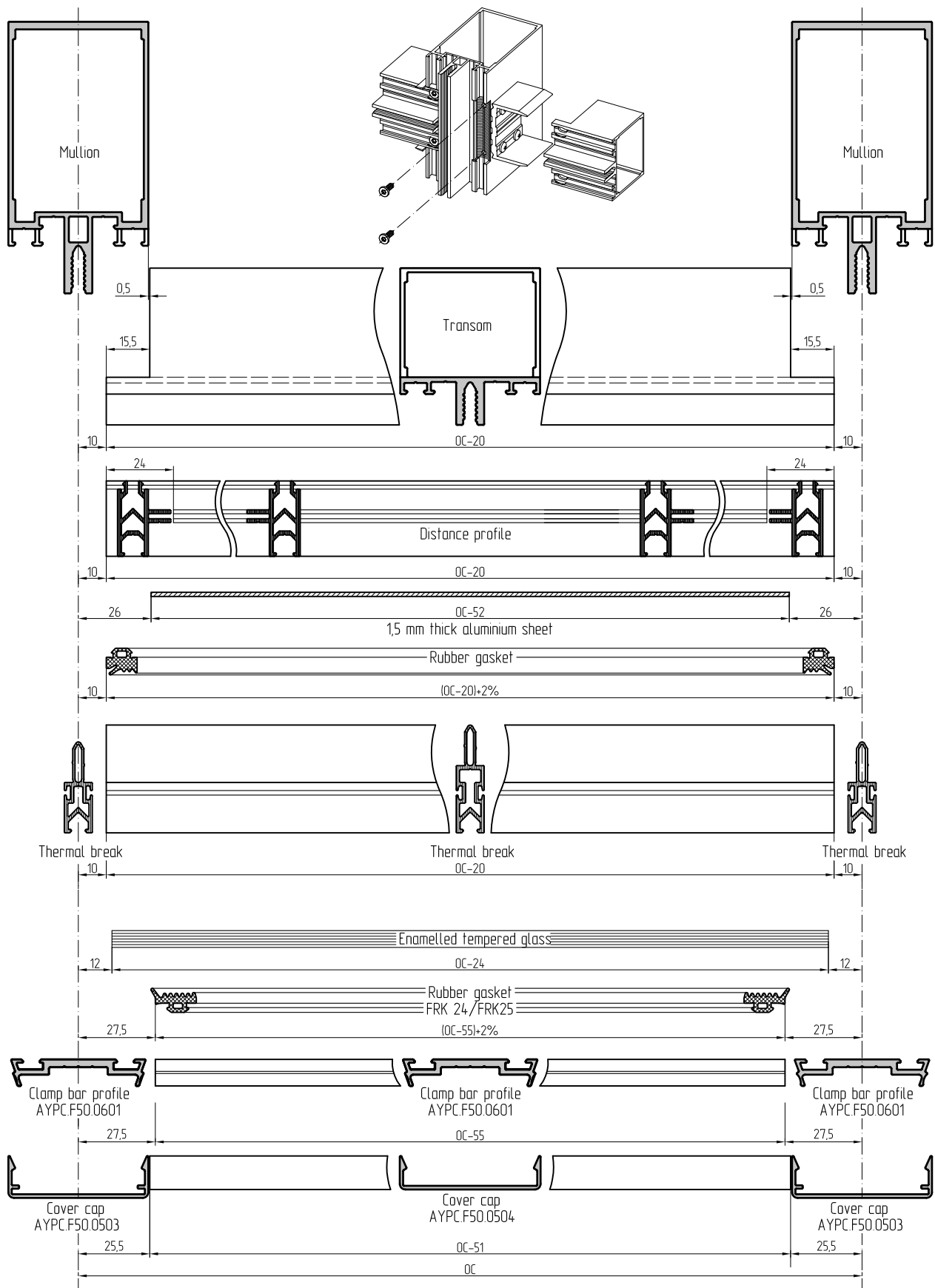

Shaped notch connection of Mullions and transoms at the opaque part of facade

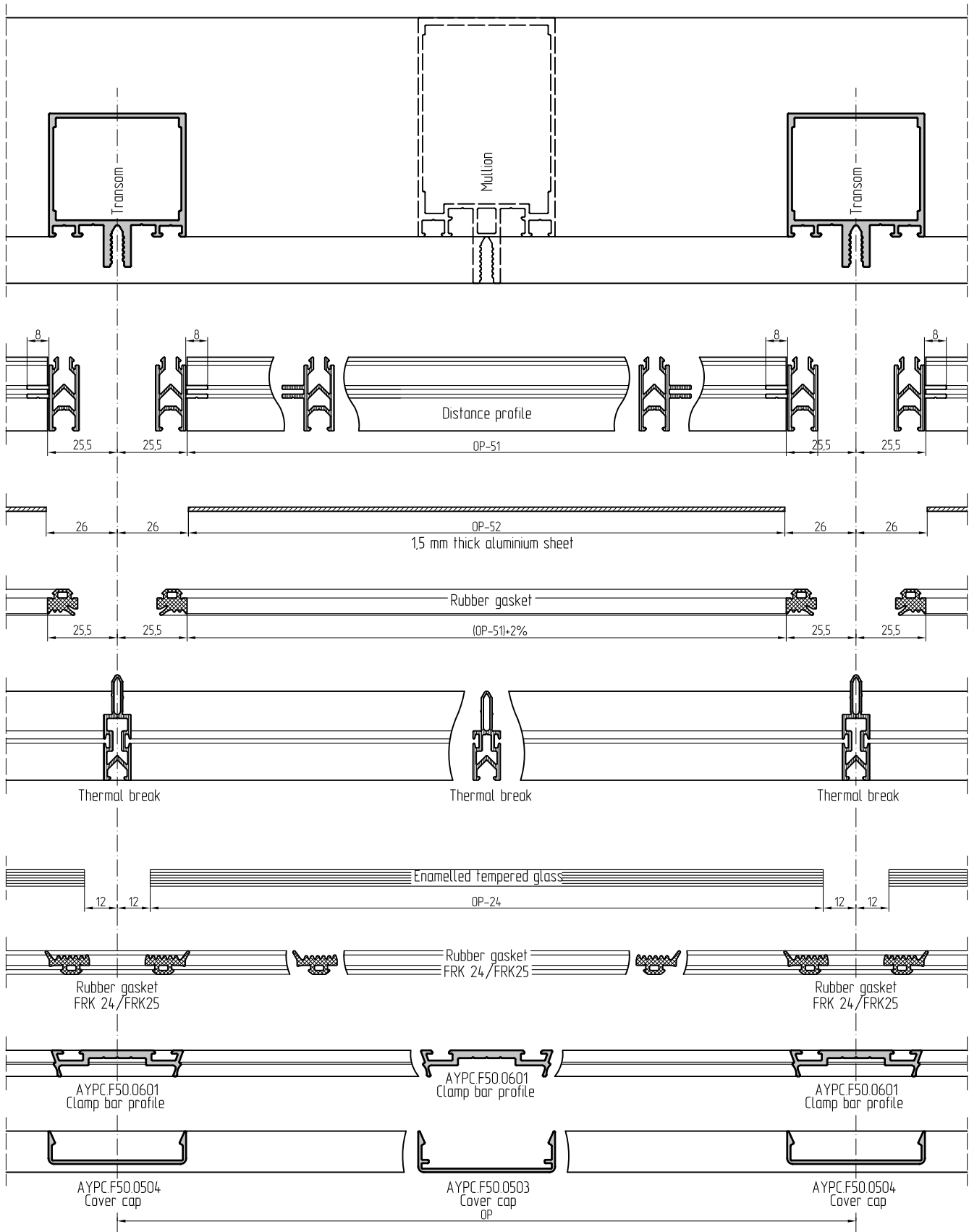

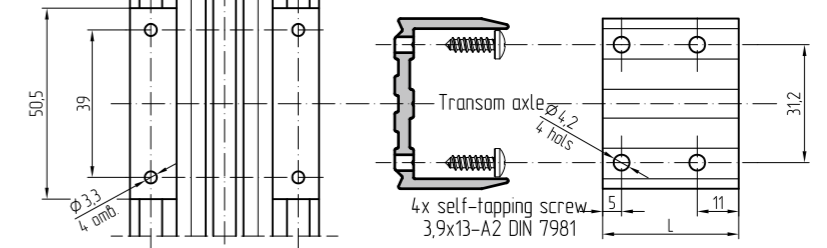
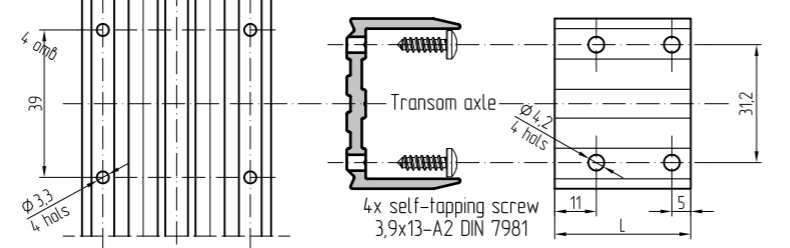
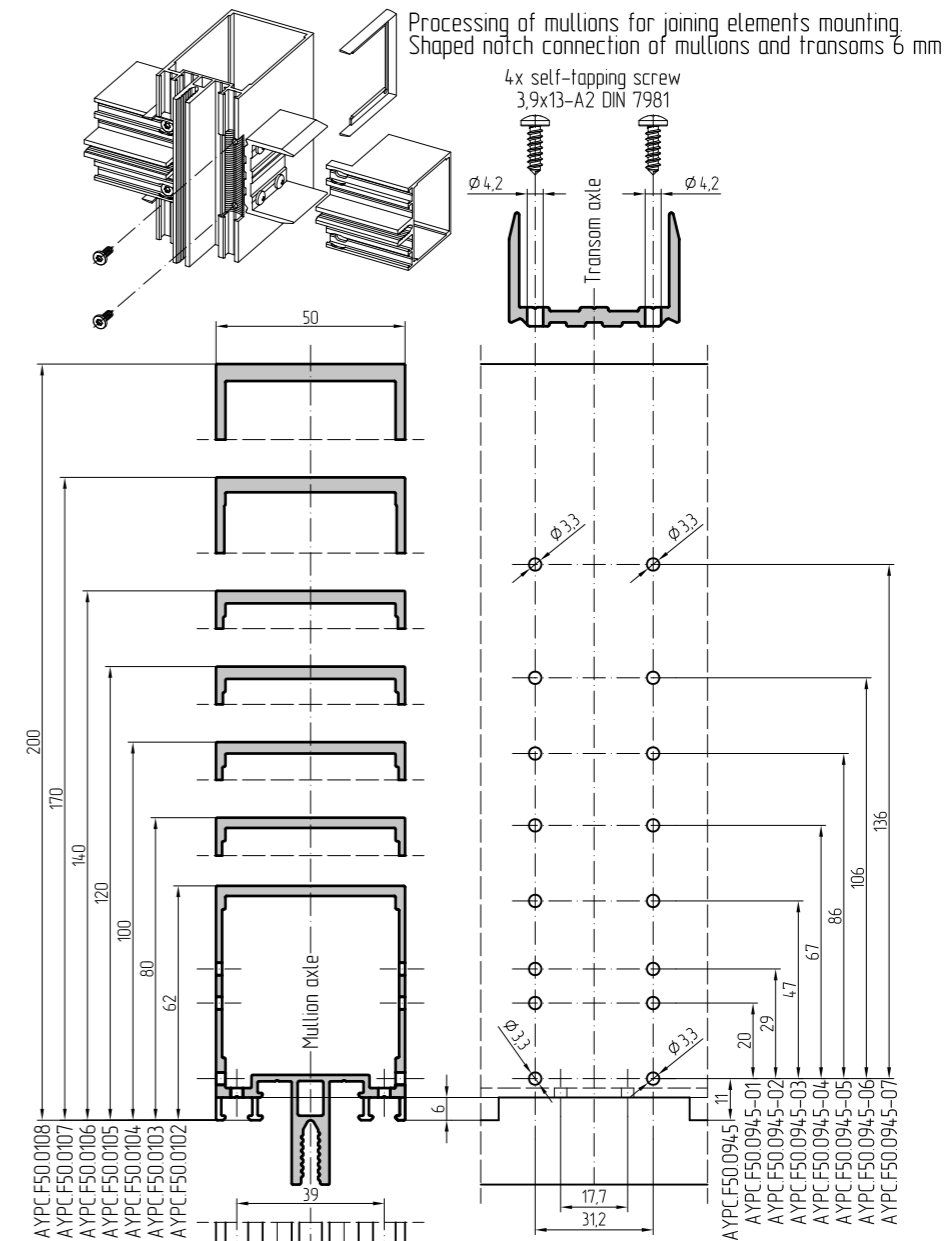
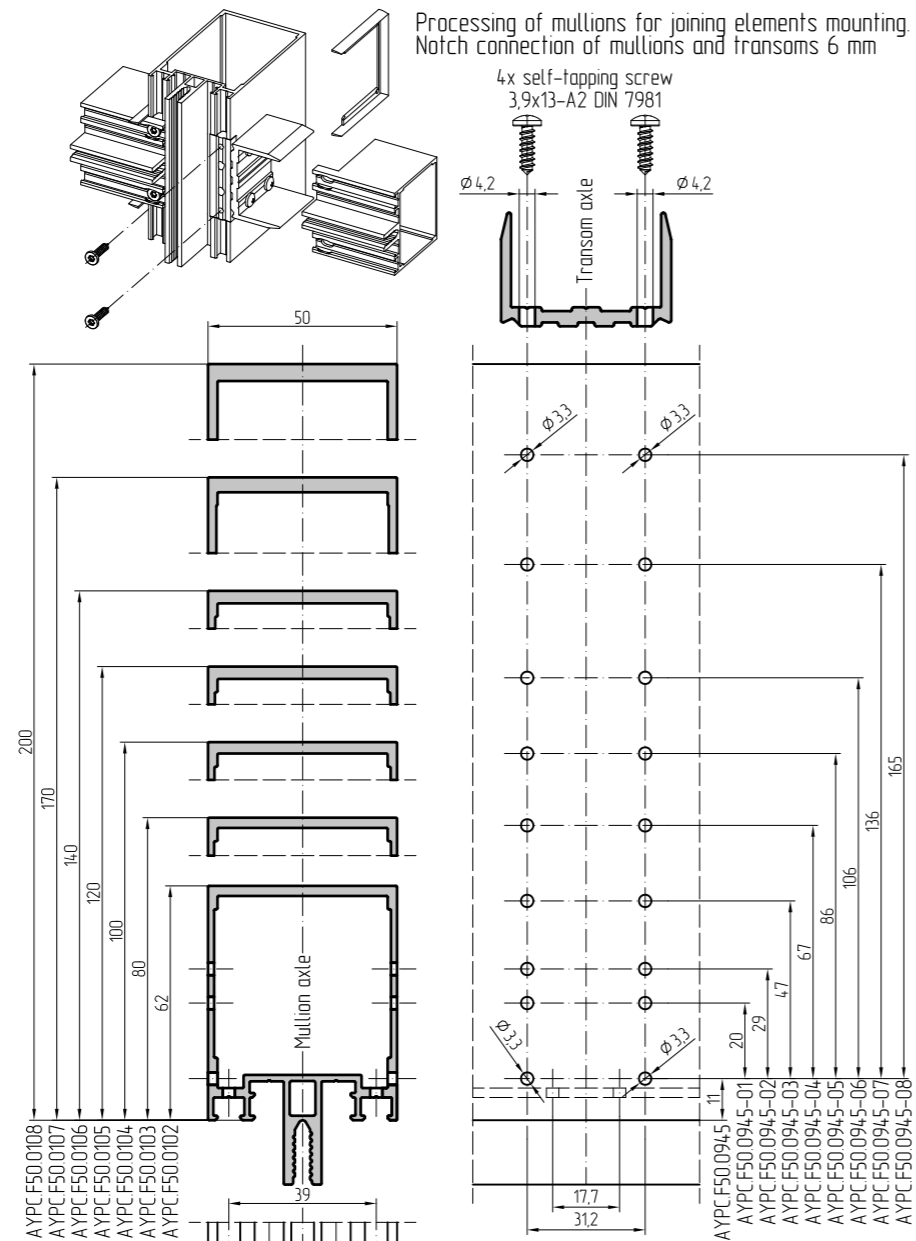

Sealing plate FRK4-2  
For connection of mullion and transom - notch connection 6 mm

Assemble after mullion processing

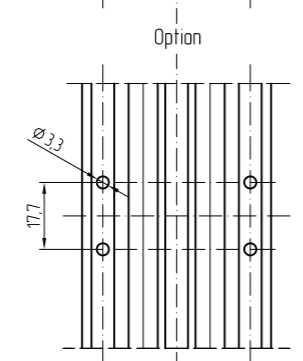

Jet nut, made from profile AYPC.F50.0405

Article	Length L, mm	For transom
AYPC.F50.0945	16	AYPC.F50.0203
AYPC.F50.0945-01	36	AYPC.F50.0204
AYPC.F50.0945-02	45	AYPC.F50.0205 AYPC.F50.0214
AYPC.F50.0945-03	63	AYPC.F50.0206
AYPC.F50.0945-04	83	AYPC.F50.0207
AYPC.F50.0945-05	102	AYPC.F50.0208
AYPC.F50.0945-06	122	AYPC.F50.0209
AYPC.F50.0945-07	152	AYPC.F50.0210
AYPC.F50.0945-08	181	AYPC.F50.0211

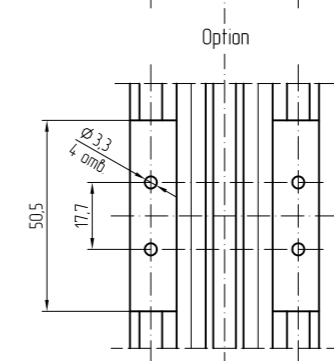

Jet nut, made from profile AYPC.F50.0405

Article	Length L, mm	For transom
AYPC.F50.0945	16	AYPC.F50.0203
AYPC.F50.0945-01	36	AYPC.F50.0204
AYPC.F50.0945-02	45	AYPC.F50.0205 AYPC.F50.0214
AYPC.F50.0945-03	63	AYPC.F50.0206
AYPC.F50.0945-04	83	AYPC.F50.0207
AYPC.F50.0945-05	102	AYPC.F50.0208
AYPC.F50.0945-06	122	AYPC.F50.0209
AYPC.F50.0945-07	152	AYPC.F50.0210





Processing of Mullions for joining elements mounting.  
Notch connection of Mullions and transoms 6 mm

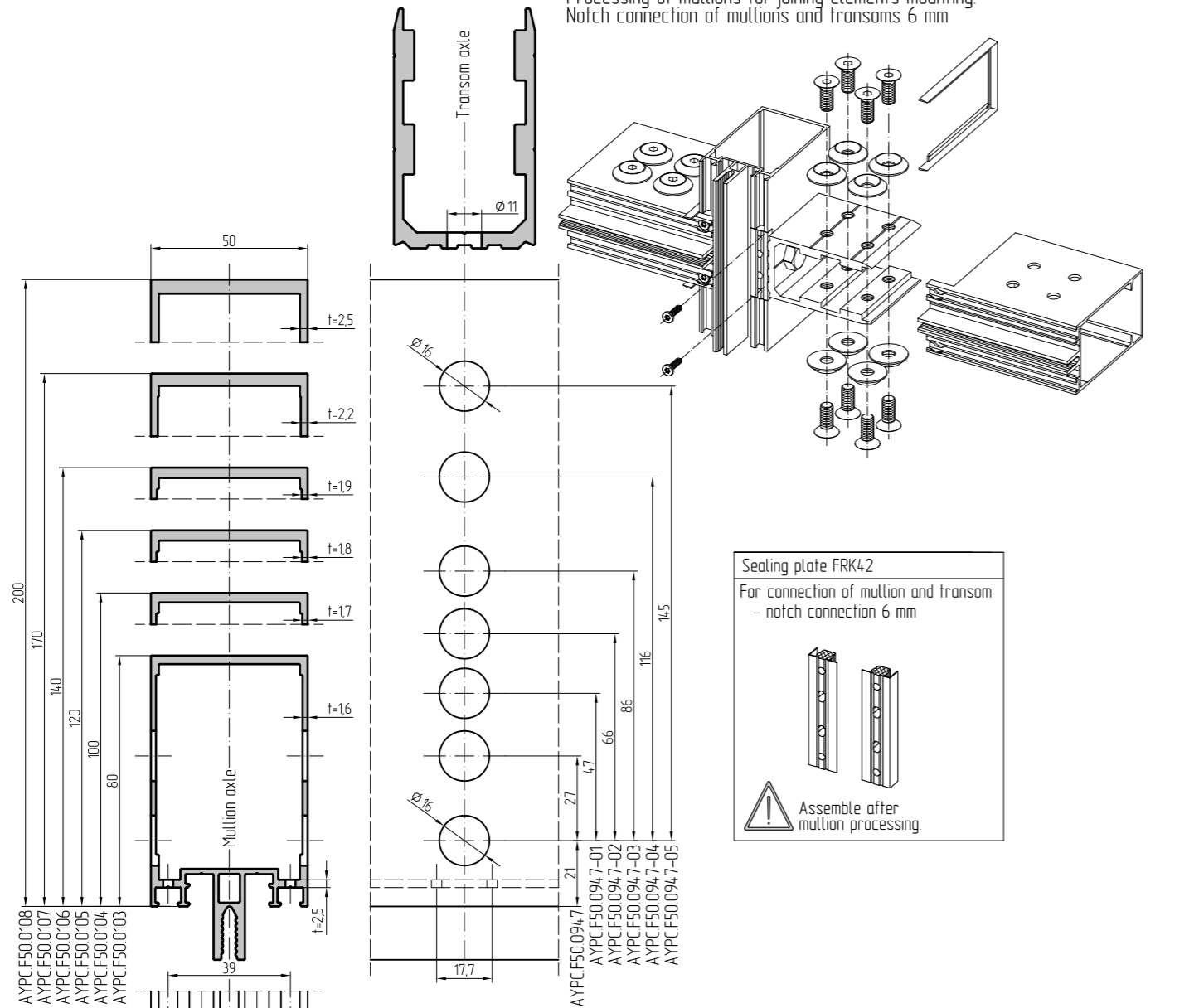

Processing of Mullions for joining elements mounting.  
Shaped notch connection of Mullions and transoms 6 mm

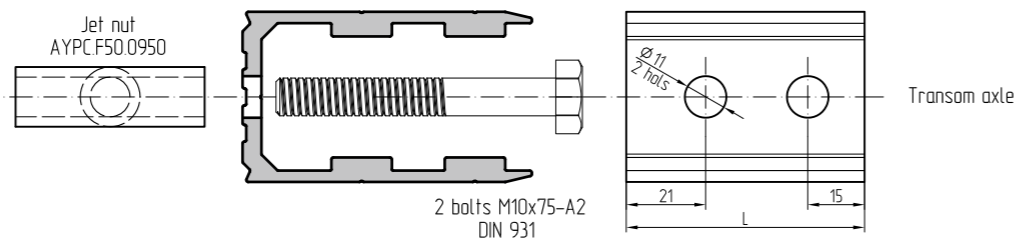
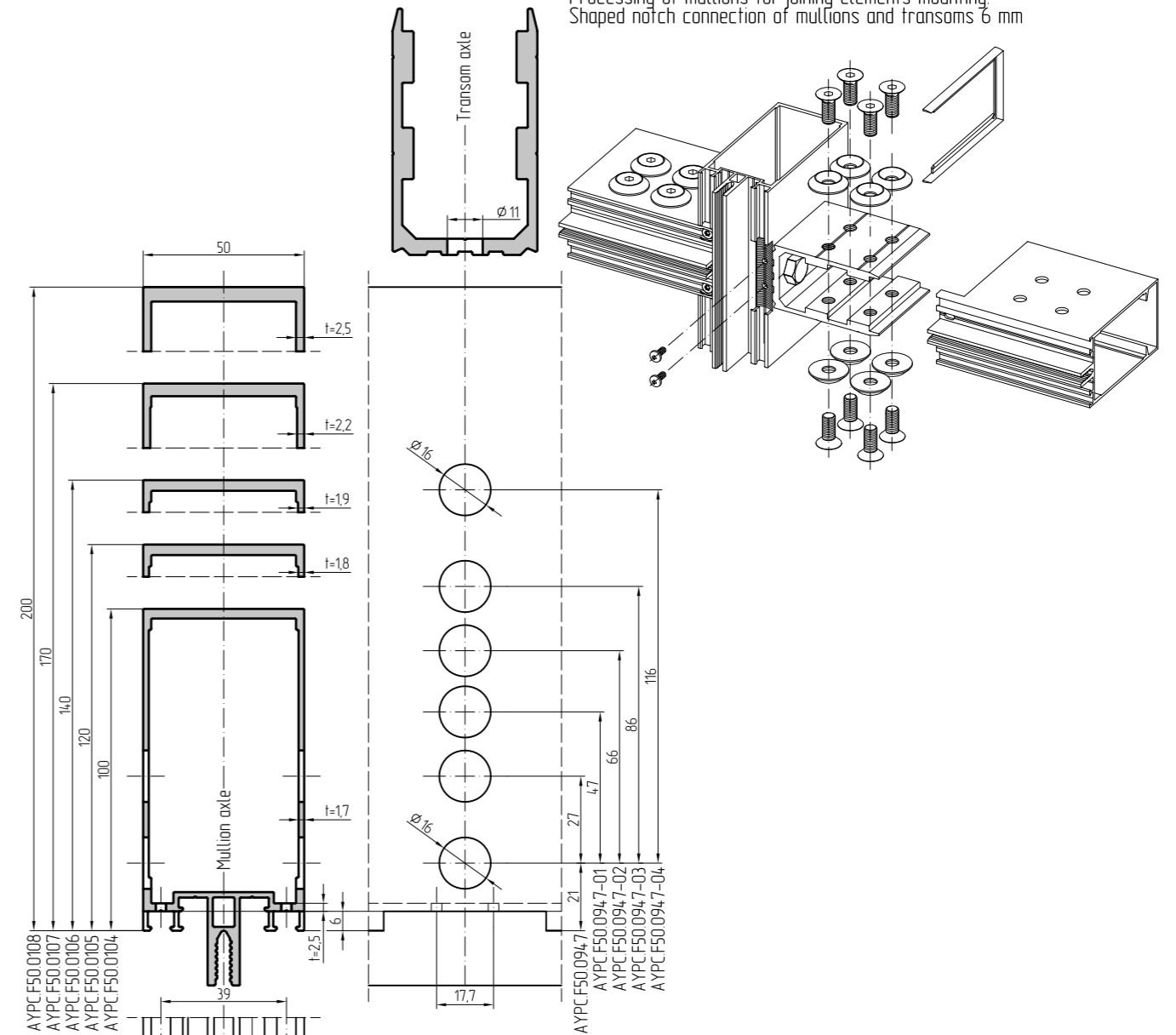

Jet nut made from profile AYPC.F50.0407		
Article	Length L, mm	For transom
AYPC.F50.0947	63	AYPC.F50.0206
AYPC.F50.0947-01	83	AYPC.F50.0207
AYPC.F50.0947-02	102	AYPC.F50.0208
AYPC.F50.0947-03	122	AYPC.F50.0209
AYPC.F50.0947-04	152	AYPC.F50.0210
AYPC.F50.0947-05	181	AYPC.F50.0211

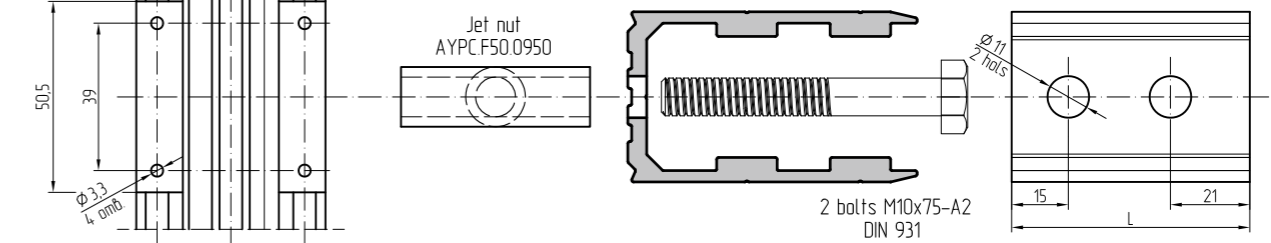

Jet nut made from profile AYPC.F50.0407		
Article	Length L, mm	For transom
AYPC.F50.0947	63	AYPC.F50.0206
AYPC.F50.0947-01	83	AYPC.F50.0207
AYPC.F50.0947-02	102	AYPC.F50.0208
AYPC.F50.0947-03	122	AYPC.F50.0209
AYPC.F50.0947-04	152	AYPC.F50.0210

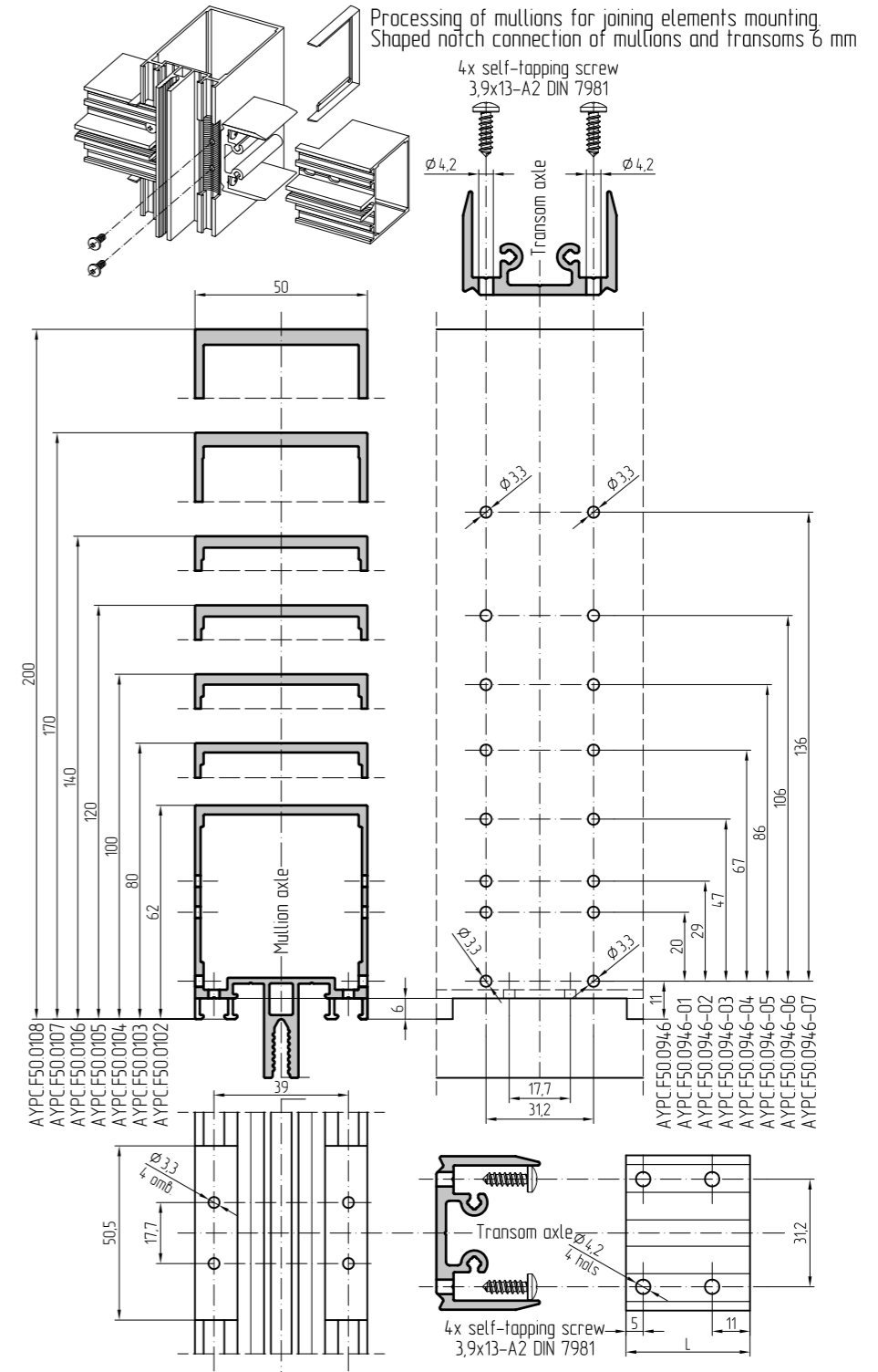
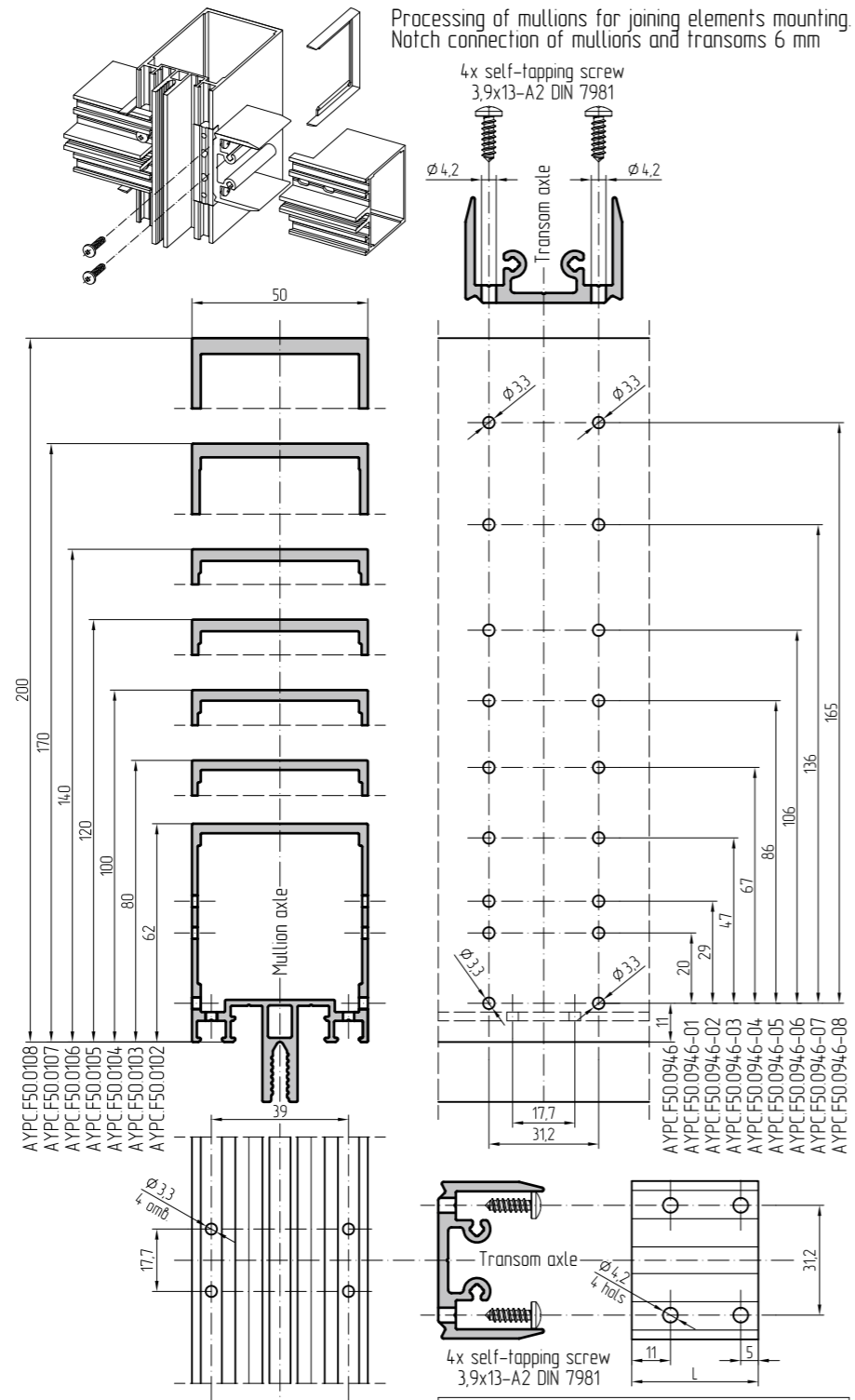

Sealing plate FRK42  
For connection of mullion and transom - notch connection 6 mm

Assemble after mullion processing

Jet nut made from profile AYPC.F50.0410		
Article	Length L, mm	For transom
AYPC.F50.0946	16	AYPC.F50.0203
AYPC.F50.0946-01	36	AYPC.F50.0204
AYPC.F50.0946-02	45	AYPC.F50.0205 AYPC.F50.0214
AYPC.F50.0946-03	63	AYPC.F50.0206
AYPC.F50.0946-04	83	AYPC.F50.0207
AYPC.F50.0946-05	102	AYPC.F50.0208
AYPC.F50.0946-06	122	AYPC.F50.0209
AYPC.F50.0946-07	152	AYPC.F50.0210
AYPC.F50.0946-08	181	AYPC.F50.0211

Jet nut made from profile AYPC.F50.0410		
Article	Length L, mm	For transom
AYPC.F50.0946	16	AYPC.F50.0203
AYPC.F50.0946-01	36	AYPC.F50.0204
AYPC.F50.0946-02	45	AYPC.F50.0205 AYPC.F50.0214
AYPC.F50.0946-03	63	AYPC.F50.0206
AYPC.F50.0946-04	83	AYPC.F50.0207
AYPC.F50.0946-05	102	AYPC.F50.0208
AYPC.F50.0946-06	122	AYPC.F50.0209
AYPC.F50.0946-07	152	AYPC.F50.0210

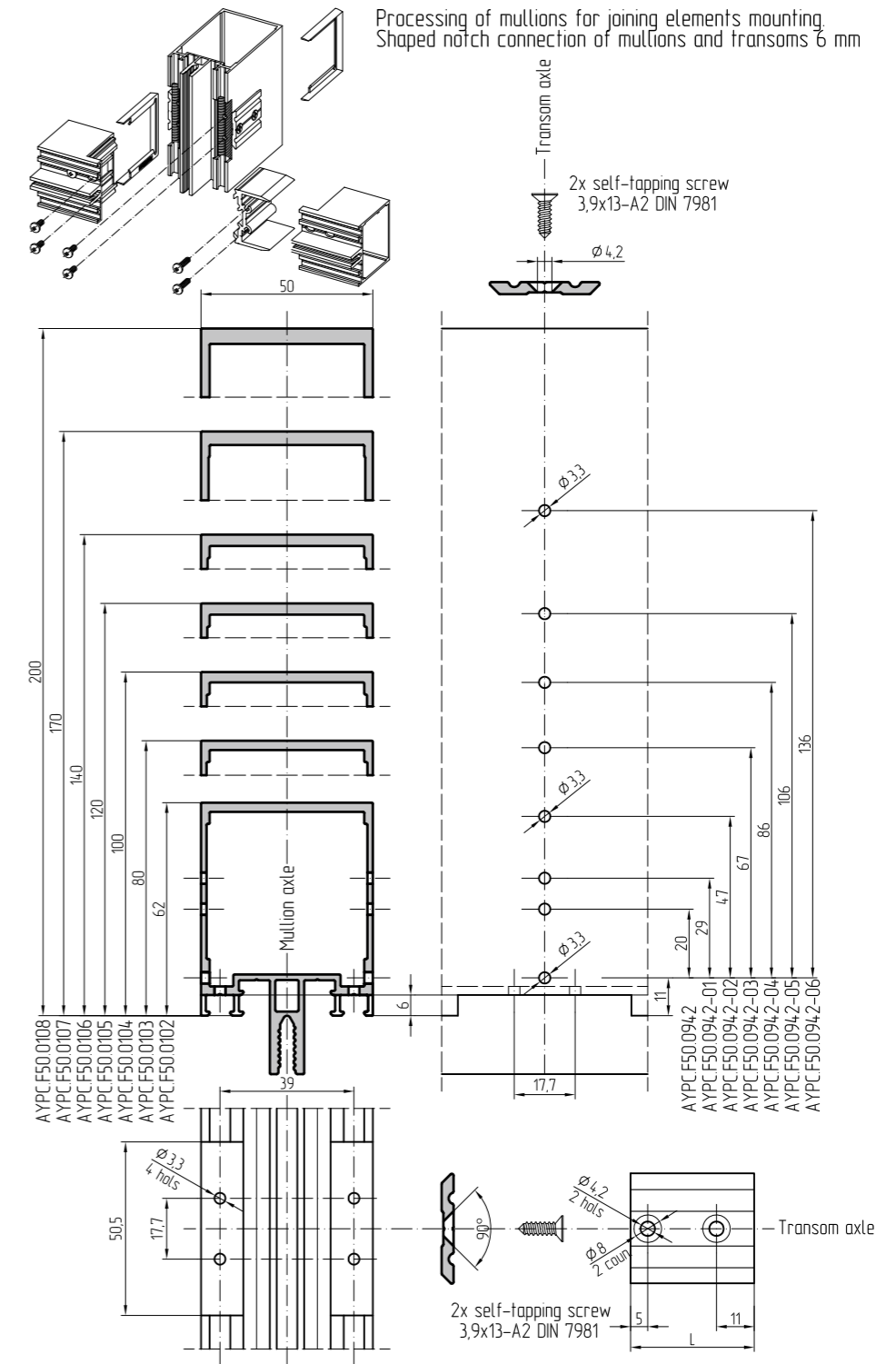
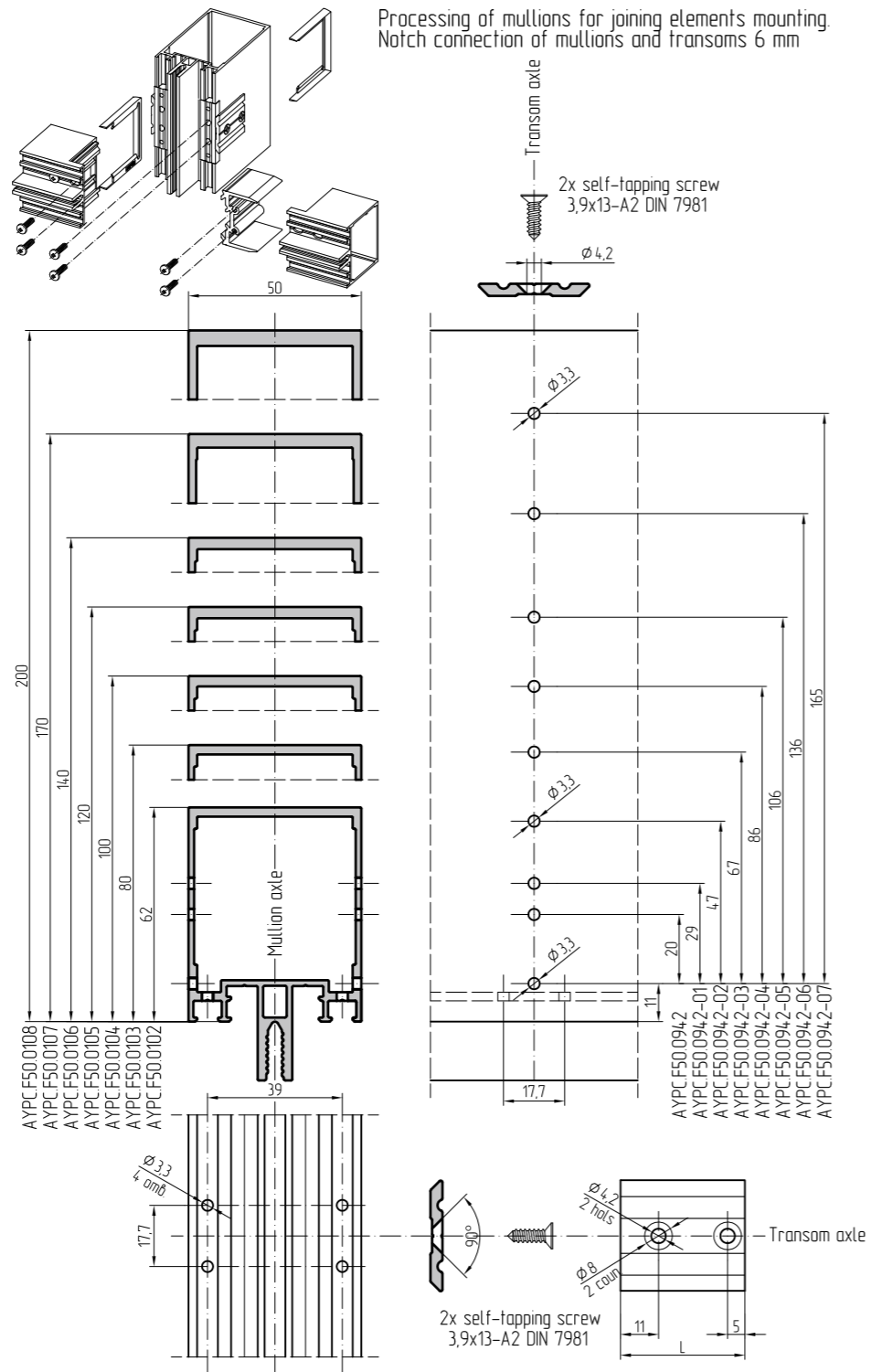

Sealing plate FRK42  
For connection of mullion and transom  
- notch connection 6 mm

Assemble after  
mullion processing

Jet nut made from profile AYPC.F50.0402

Article	Length L, mm	For transom
AYPC.F50.0942	36	AYPC.F50.0204
AYPC.F50.0942-01	45	AYPC.F50.0205 AYPC.F50.0214
AYPC.F50.0942-02	63	AYPC.F50.0206
AYPC.F50.0942-03	83	AYPC.F50.0207
AYPC.F50.0942-04	102	AYPC.F50.0208
AYPC.F50.0942-05	122	AYPC.F50.0209
AYPC.F50.0942-06	152	AYPC.F50.0210
AYPC.F50.0942-07	181	AYPC.F50.0211

Jet nut made from profile AYPC.F50.0402

Article	Length L, mm	For transom
AYPC.F50.0942	36	AYPC.F50.0204
AYPC.F50.0942-01	45	AYPC.F50.0205 AYPC.F50.0214
AYPC.F50.0942-02	63	AYPC.F50.0206
AYPC.F50.0942-03	83	AYPC.F50.0207
AYPC.F50.0942-04	102	AYPC.F50.0208
AYPC.F50.0942-05	122	AYPC.F50.0209
AYPC.F50.0942-06	152	AYPC.F50.0210

Processing of mullions for joining elements mounting  
Notch connection of mullions and transoms 6 mm

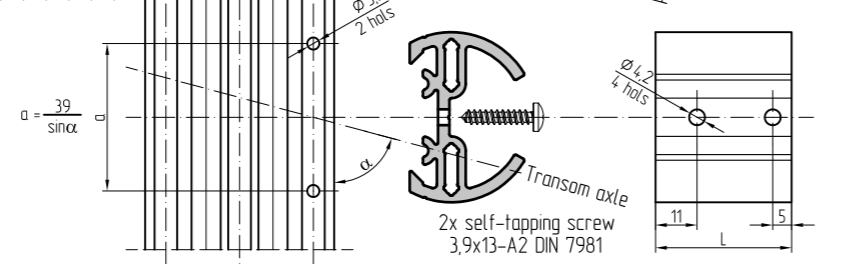
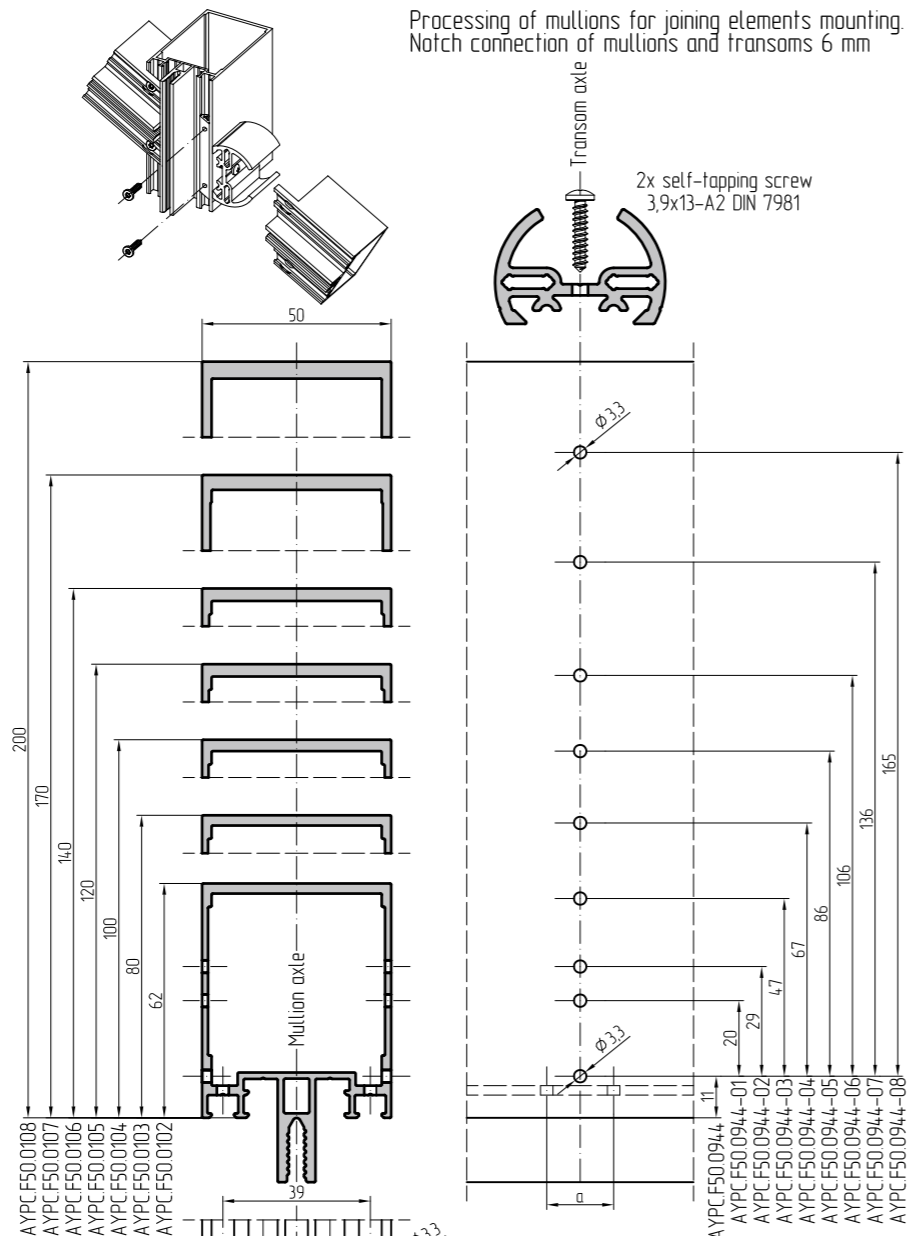

Jet nut made from profile AYPC.F50.0404

Article	Length L, mm	For transom
AYPC.F50.0944	16	AYPC.F50.0203
AYPC.F50.0944-01	36	AYPC.F50.0204
AYPC.F50.0944-02	45	AYPC.F50.0205
AYPC.F50.0944-03	63	AYPC.F50.0206
AYPC.F50.0944-04	83	AYPC.F50.0207
AYPC.F50.0944-05	102	AYPC.F50.0208
AYPC.F50.0944-06	122	AYPC.F50.0209
AYPC.F50.0944-07	152	AYPC.F50.0210
AYPC.F50.0944-08	181	AYPC.F50.0211

Processing of mullions for joining elements mounting  
Shaped notch connection of mullions and transoms 6 mm

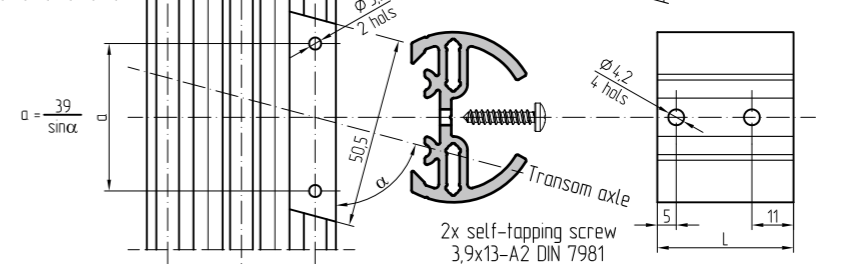
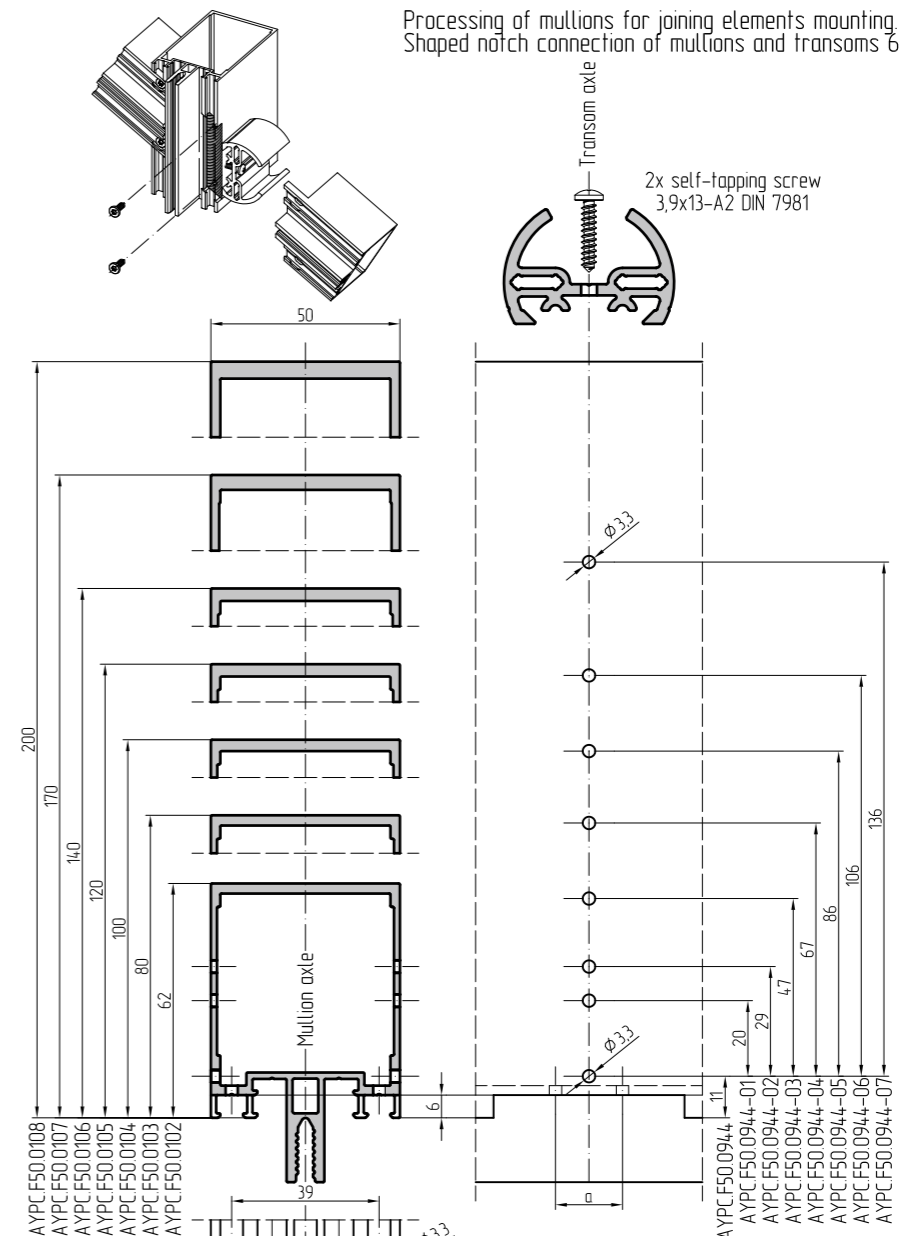

Jet nut made from profile AYPC.F50.0404

Article	Length L, mm	For transom
AYPC.F50.0944	16	AYPC.F50.0203
AYPC.F50.0944-01	36	AYPC.F50.0204
AYPC.F50.0944-02	45	AYPC.F50.0205
AYPC.F50.0944-03	63	AYPC.F50.0206
AYPC.F50.0944-04	83	AYPC.F50.0207
AYPC.F50.0944-05	102	AYPC.F50.0208
AYPC.F50.0944-06	122	AYPC.F50.0209
AYPC.F50.0944-07	152	AYPC.F50.0210

Sealing plate FRK42  
For connection of mullion and transom  
- notch connection 6 mm

Assemble after mullion processing

Processing of mounting mullions for joining element assemblage.  
Notch connection of mounting mullions and transoms 6 mm

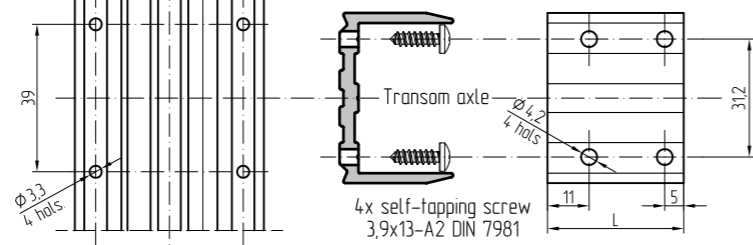
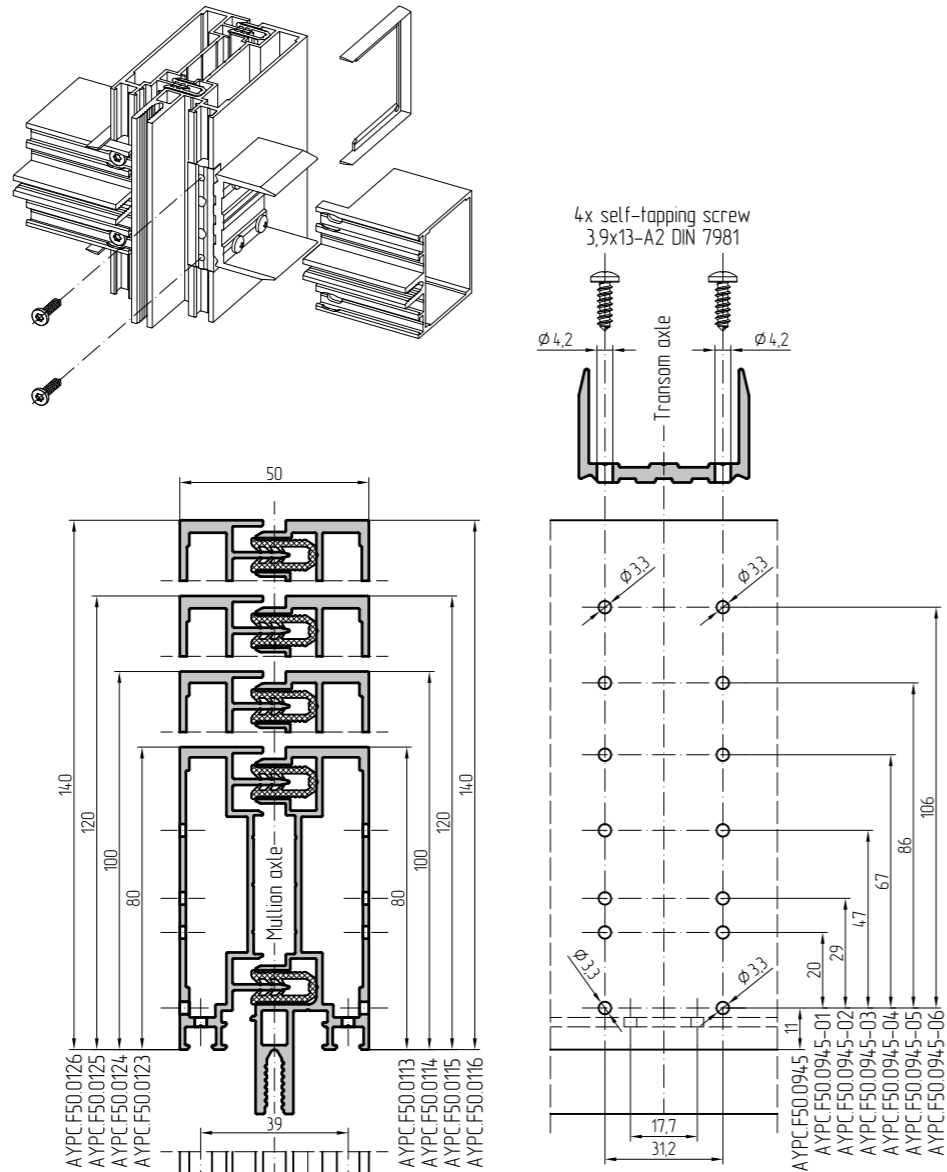

Sealing plate FRK42  
For connection of mullion and transom - notch connection 6 mm

Assemble after mullion processing

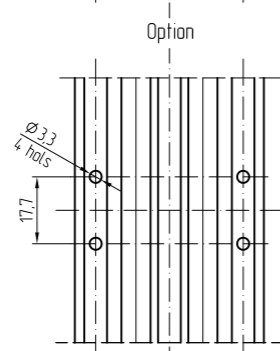

Joining element made from profile AYPF50.0405		
Article	Length L, mm	For transom
AYPC.F50.0945	16	AYPC.F50.0203
AYPC.F50.0945-01	36	AYPC.F50.0204
AYPC.F50.0945-02	45	AYPC.F50.0205
		AYPC.F50.0214
AYPC.F50.0945-03	63	AYPC.F50.0206
AYPC.F50.0945-04	83	AYPC.F50.0207
AYPC.F50.0945-05	102	AYPC.F50.0208
AYPC.F50.0945-06	122	AYPC.F50.0209

Processing of mounting mullions for joining element assemblage.  
Shaped notch connection of mounting mullions and transoms 6 mm

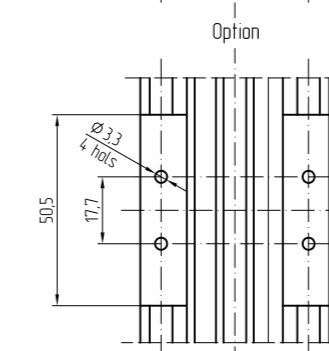
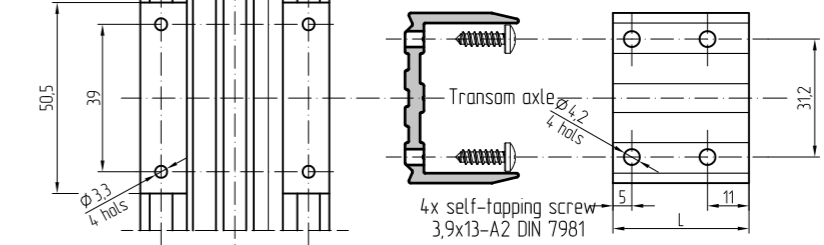
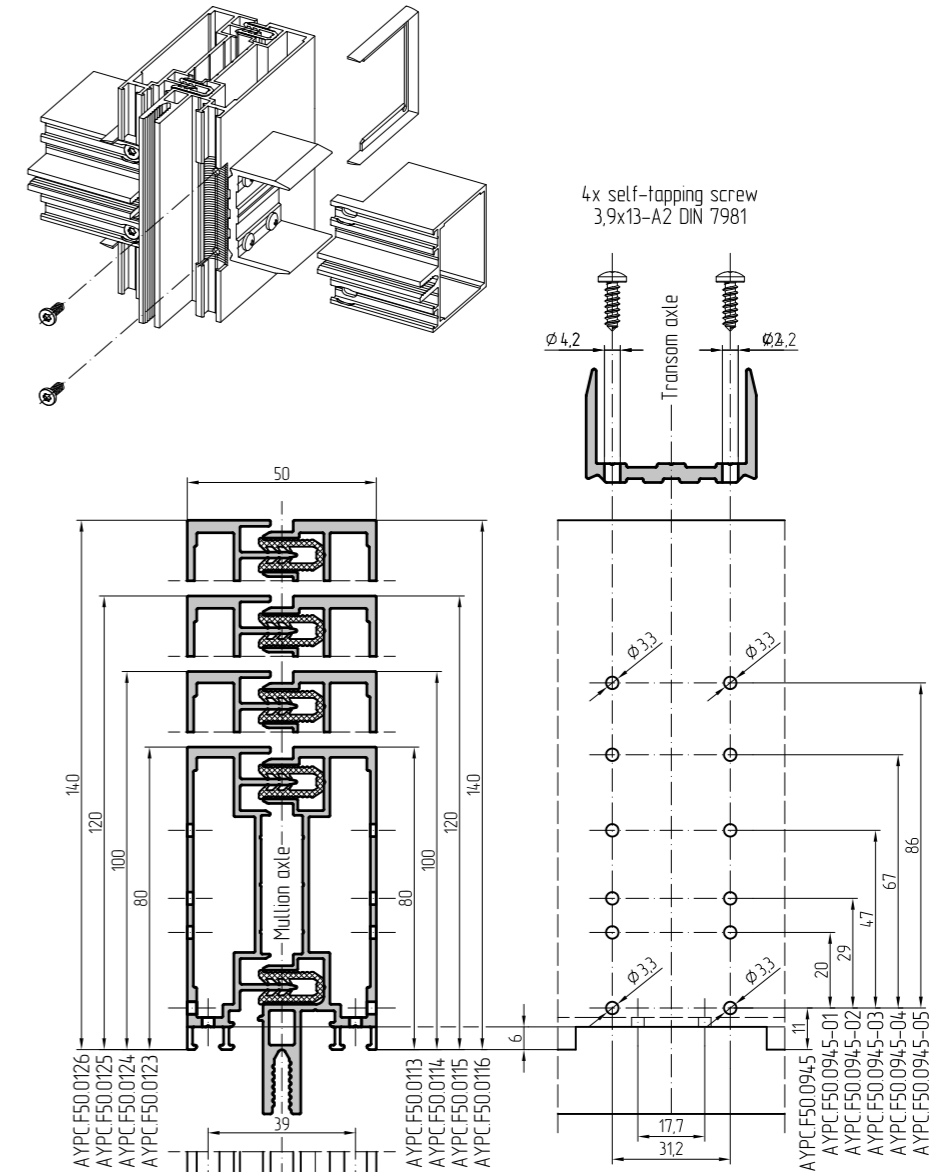

Joining element made from profile AYPF50.0405		
Article	Length L, mm	For transom
AYPC.F50.0945	16	AYPC.F50.0203
AYPC.F50.0945-01	36	AYPC.F50.0204
AYPC.F50.0945-02	45	AYPC.F50.0205
		AYPC.F50.0214
AYPC.F50.0945-03	63	AYPC.F50.0206
AYPC.F50.0945-04	83	AYPC.F50.0207
AYPC.F50.0945-05	102	AYPC.F50.0208



Processing of mounting mullions for joining element assemblage.  
Notch connection of mounting mullions and transoms 6 mm

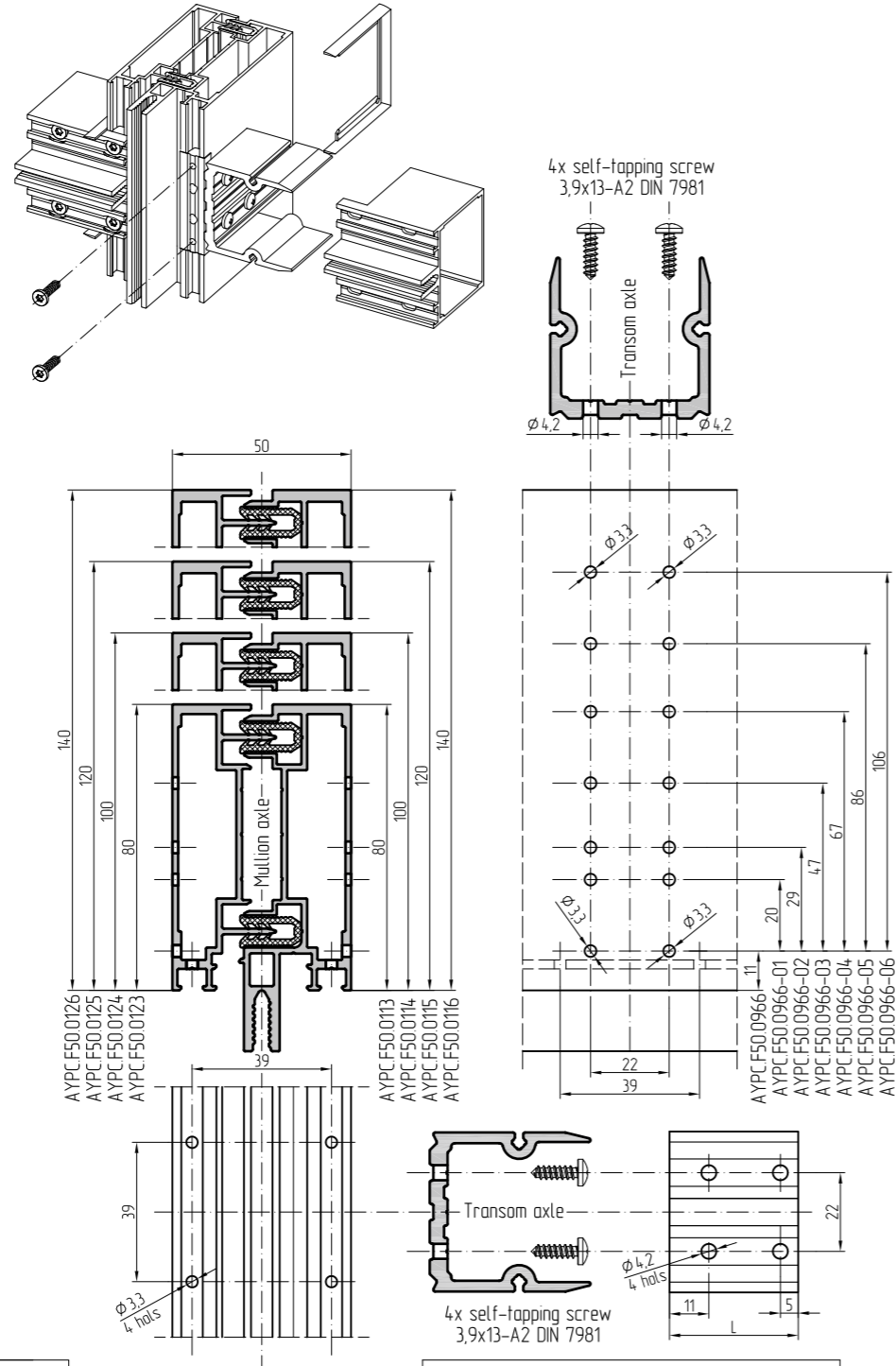

Processing of mounting mullions for joining element assemblage.  
Shaped notch connection of mounting mullions and transoms 6 mm

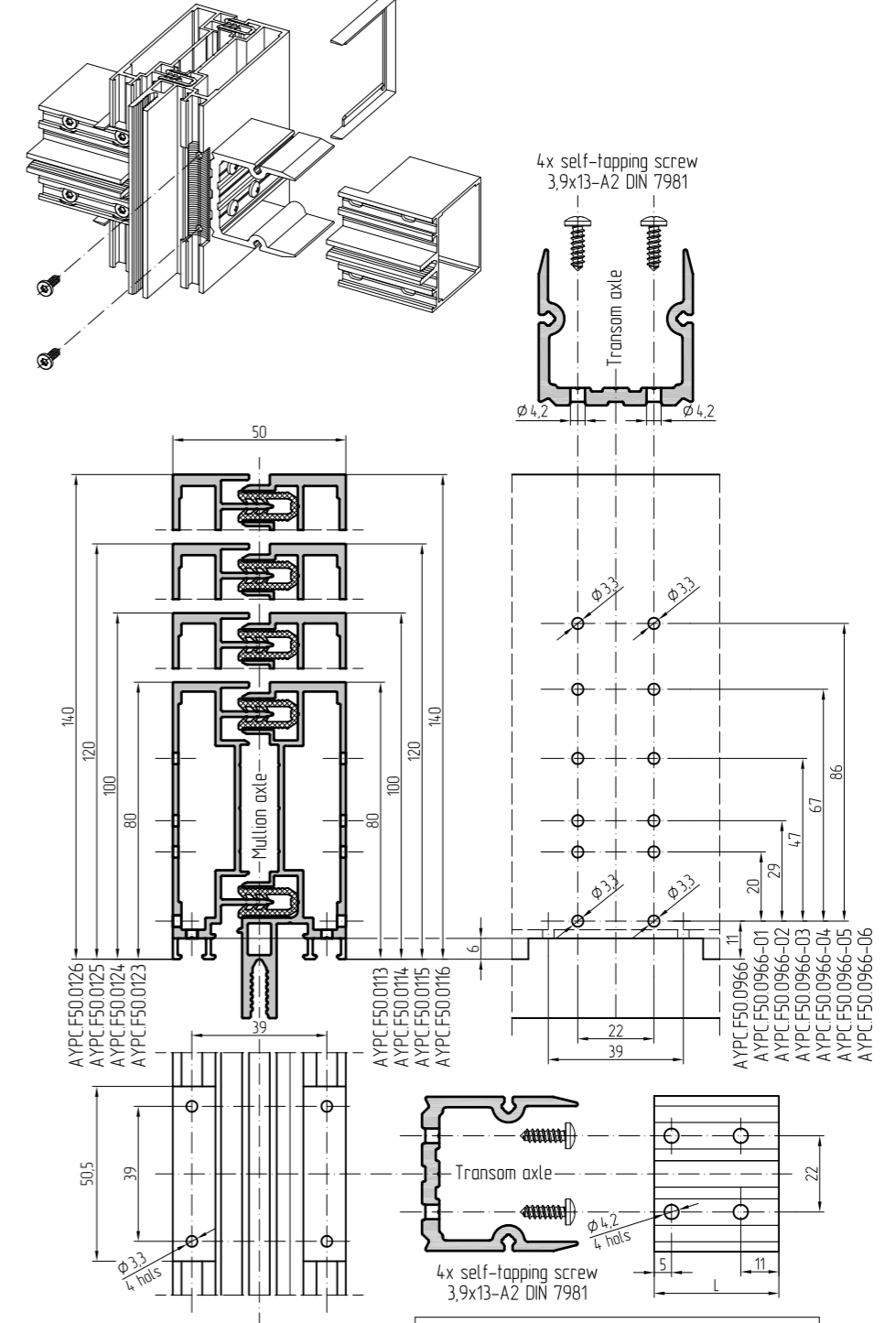

Sealing plate FRK42  
For connection of mullion and transom:  
- notch connection 6 mm

Assemble after mullion processing

Joining element made from profile AYPC.F50.0413		
Article	Length L, mm	For transom
AYPC.F50.0966	16	AYPC.F50.0203
AYPC.F50.0966-01	36	AYPC.F50.0204
AYPC.F50.0966-02	45	AYPC.F50.0205 AYPC.F50.0214
AYPC.F50.0966-03	63	AYPC.F50.0206
AYPC.F50.0966-04	83	AYPC.F50.0207
AYPC.F50.0966-05	102	AYPC.F50.0208
AYPC.F50.0966-06	122	AYPC.F50.0209

Joining element made from profile AYPC.F50.0413		
Article	Length L, mm	For transom
AYPC.F50.0966	16	AYPC.F50.0203
AYPC.F50.0966-01	36	AYPC.F50.0204
AYPC.F50.0966-02	45	AYPC.F50.0205 AYPC.F50.0214
AYPC.F50.0966-03	63	AYPC.F50.0206
AYPC.F50.0966-04	83	AYPC.F50.0207
AYPC.F50.0966-05	102	AYPC.F50.0208

Processing of mounting mullions for joining element assemblage.  
Notch connection of mounting mullions and transoms 6 mm

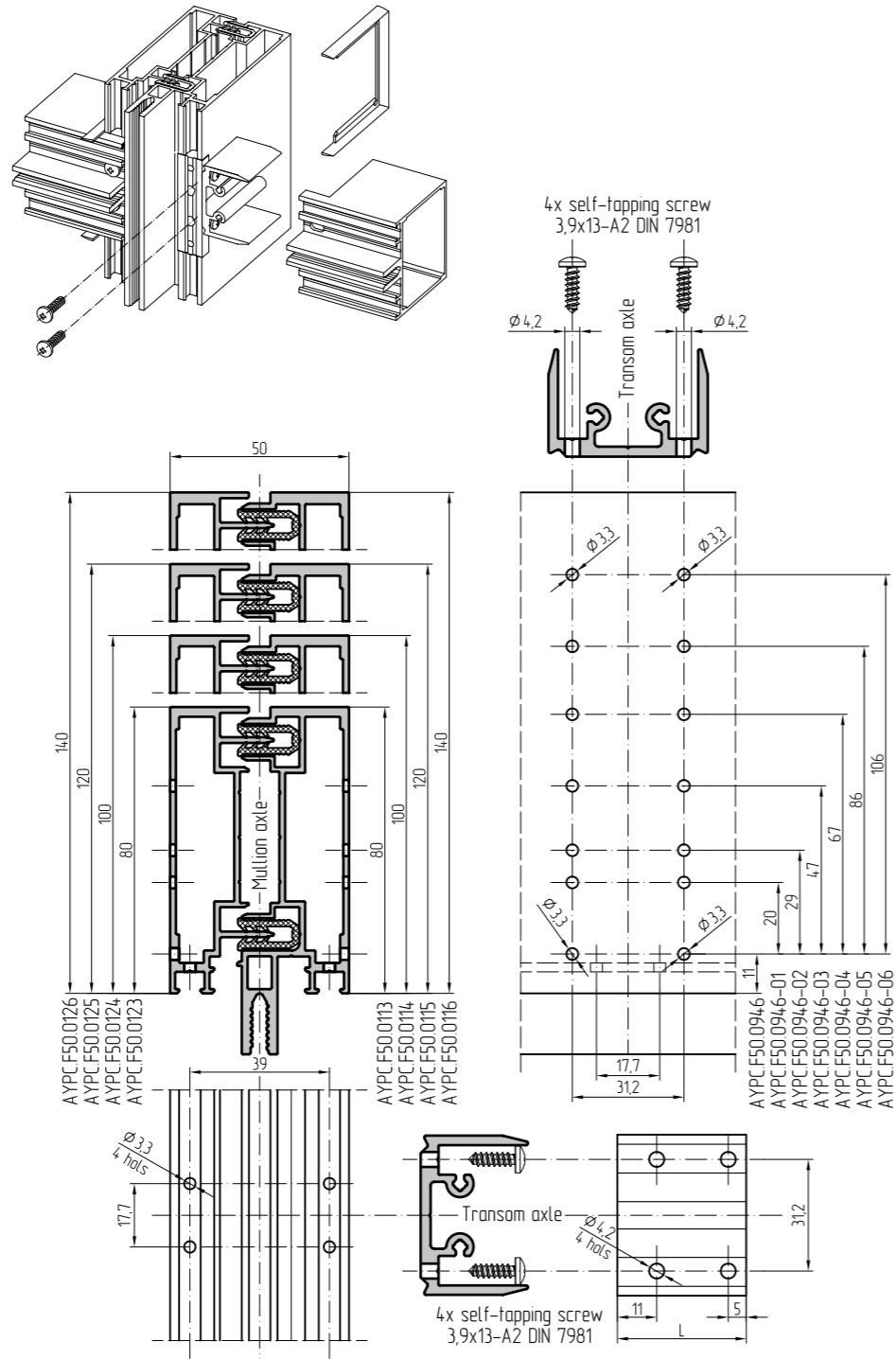

Processing of mounting mullions for joining element assemblage.  
Shaped notch connection of mounting mullions and transoms 6 mm

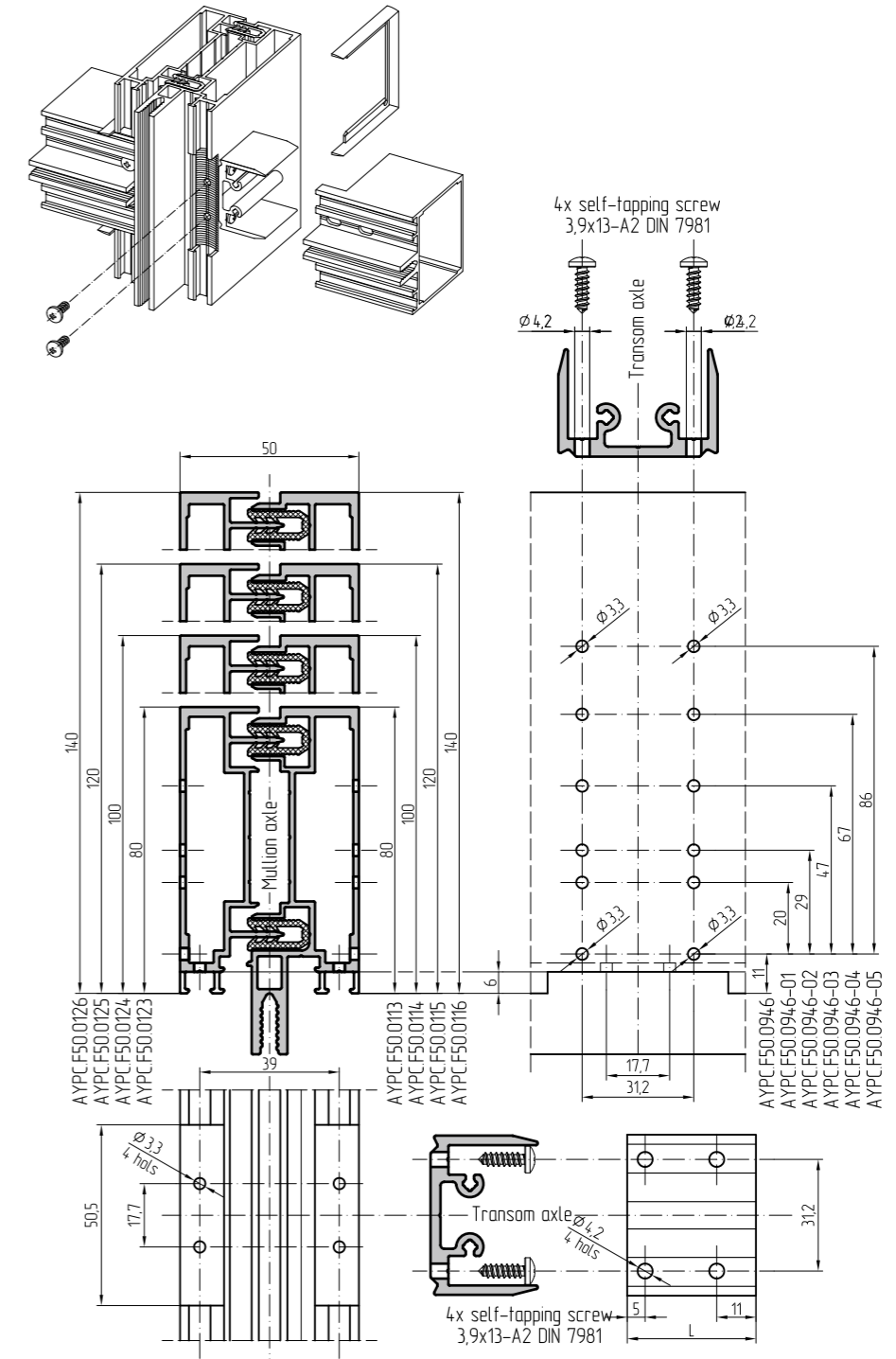

Sealing plate FRK42  
For connection of mullion and transom - notch connection 6 mm

Assemble after mullion processing

Joining element made from profile AYPC.F50.0410

Article	Length L, mm	For transom
AYPC.F50.0946	16	AYPC.F50.0203
AYPC.F50.0946-01	36	AYPC.F50.0204
AYPC.F50.0946-02	45	AYPC.F50.0205 AYPC.F50.0214
AYPC.F50.0946-03	63	AYPC.F50.0206
AYPC.F50.0946-04	83	AYPC.F50.0207
AYPC.F50.0946-05	102	AYPC.F50.0208
AYPC.F50.0946-06	122	AYPC.F50.0209

Joining element made from profile AYPC.F50.0410

Article	Length L, mm	For transom
AYPC.F50.0946	16	AYPC.F50.0203
AYPC.F50.0946-01	36	AYPC.F50.0204
AYPC.F50.0946-02	45	AYPC.F50.0205 AYPC.F50.0214
AYPC.F50.0946-03	63	AYPC.F50.0206
AYPC.F50.0946-04	83	AYPC.F50.0207
AYPC.F50.0946-05	102	AYPC.F50.0208





Processing of mounting mullions for joining element assemblage.  
Notch connection of mounting mullions and transoms 6 mm

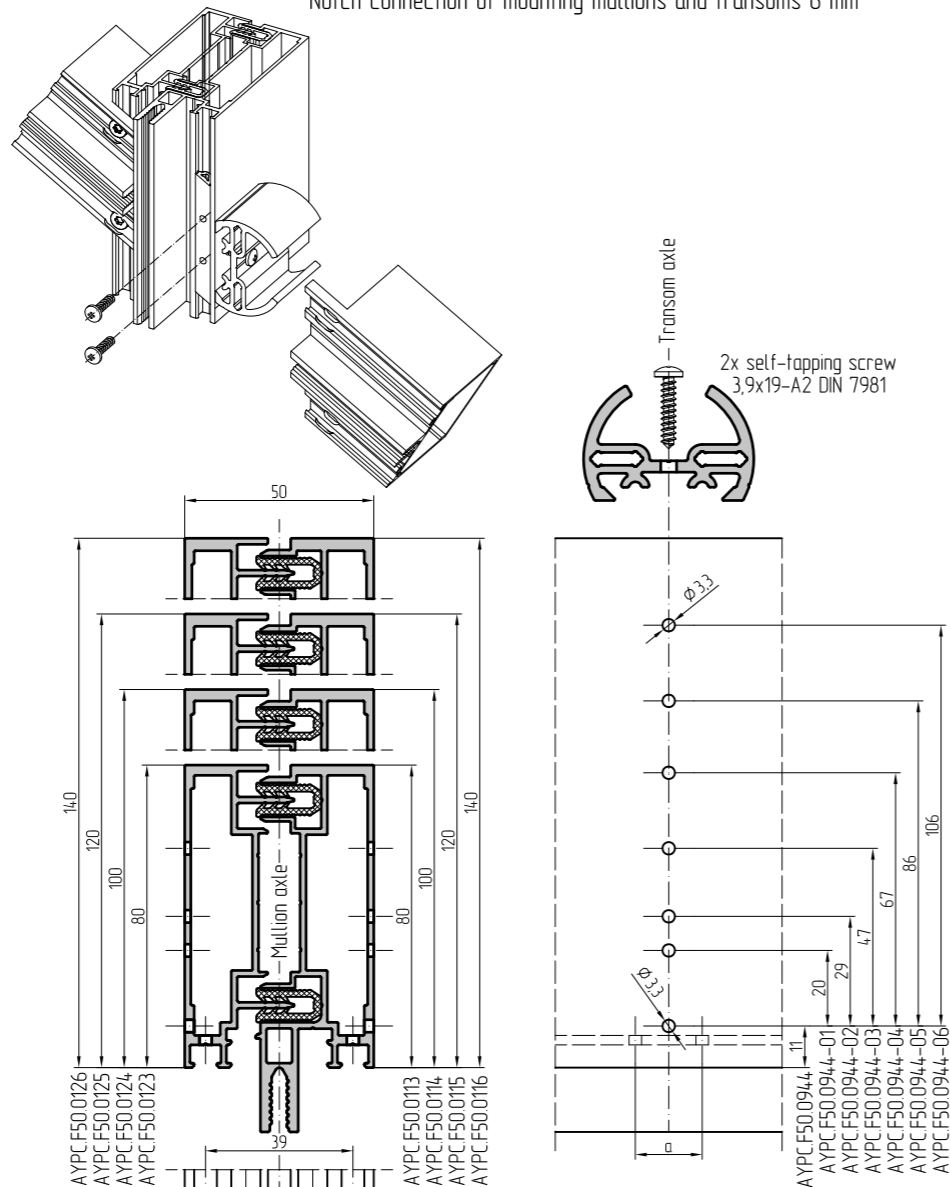

Processing of mounting mullions for joining element assemblage.  
Shaped notch connection of mounting mullions and transoms 6 mm

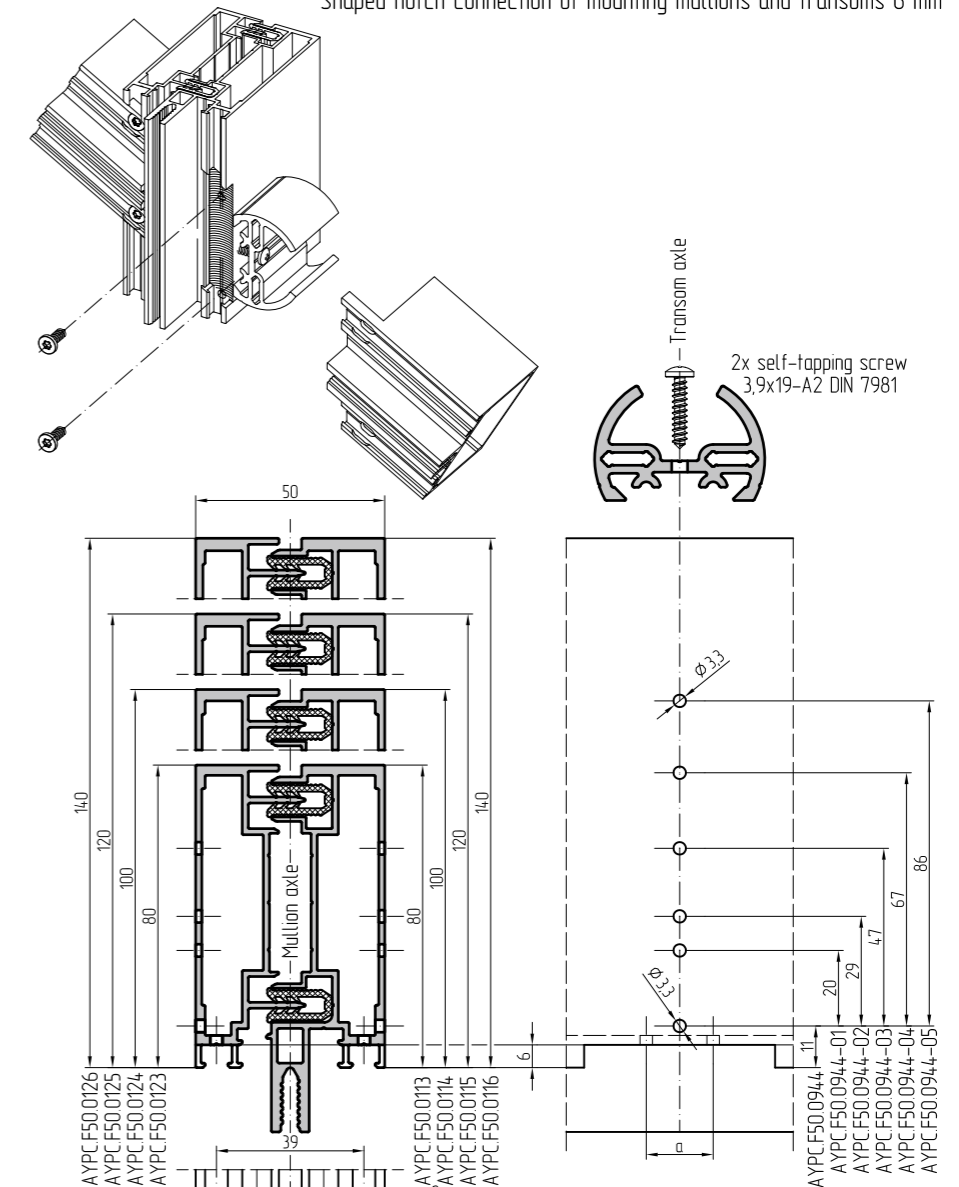

Seating plate FRK42  
For connection of mullion and transom - notch connection 6 mm

Устанавливать после обработки стоек.

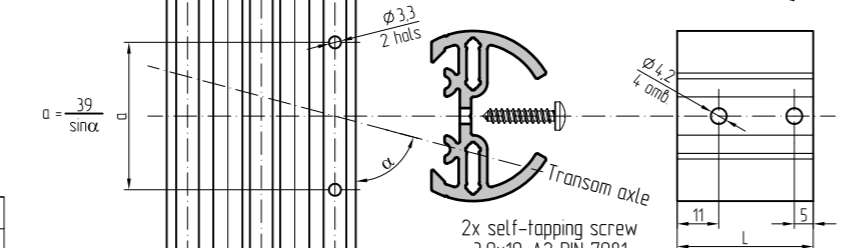

Joining element made from profile AYPC.F50.0404

Article	Length L, mm	For transom
AYPC.F50.0944	16	AYPC.F50.0203
AYPC.F50.0944-01	36	AYPC.F50.0204
AYPC.F50.0944-02	45	AYPC.F50.0205 AYPC.F50.0214
AYPC.F50.0944-03	63	AYPC.F50.0206
AYPC.F50.0944-04	83	AYPC.F50.0207
AYPC.F50.0944-05	102	AYPC.F50.0208
AYPC.F50.0944-06	122	AYPC.F50.0209

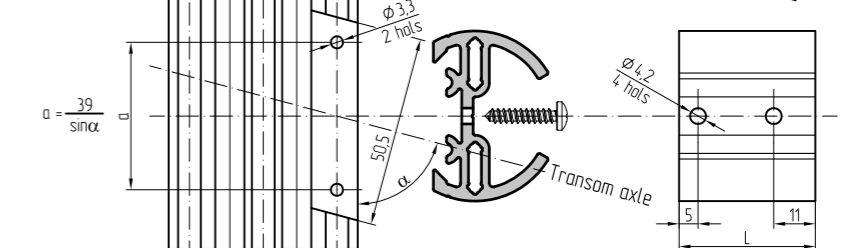
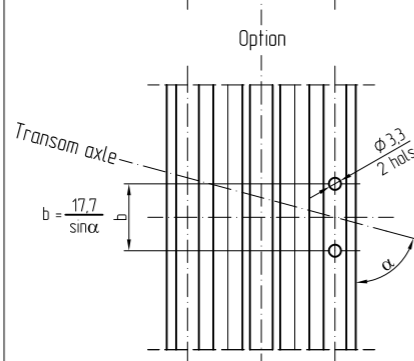

Joining element made from profile AYPC.F50.0404

Article	Length L, mm	For transom
AYPC.F50.0944	16	AYPC.F50.0203
AYPC.F50.0944-01	36	AYPC.F50.0204
AYPC.F50.0944-02	45	AYPC.F50.0205 AYPC.F50.0214
AYPC.F50.0944-03	63	AYPC.F50.0206
AYPC.F50.0944-04	83	AYPC.F50.0207
AYPC.F50.0944-05	102	AYPC.F50.0208

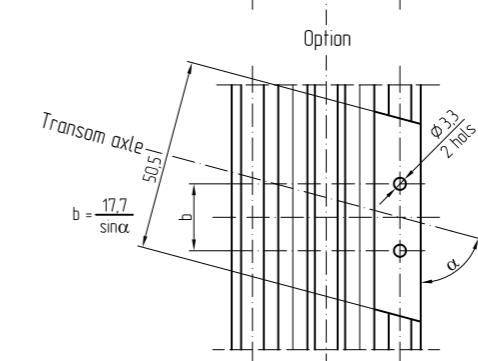

Processing of notch connection transom 6 mm without plastic end plugs

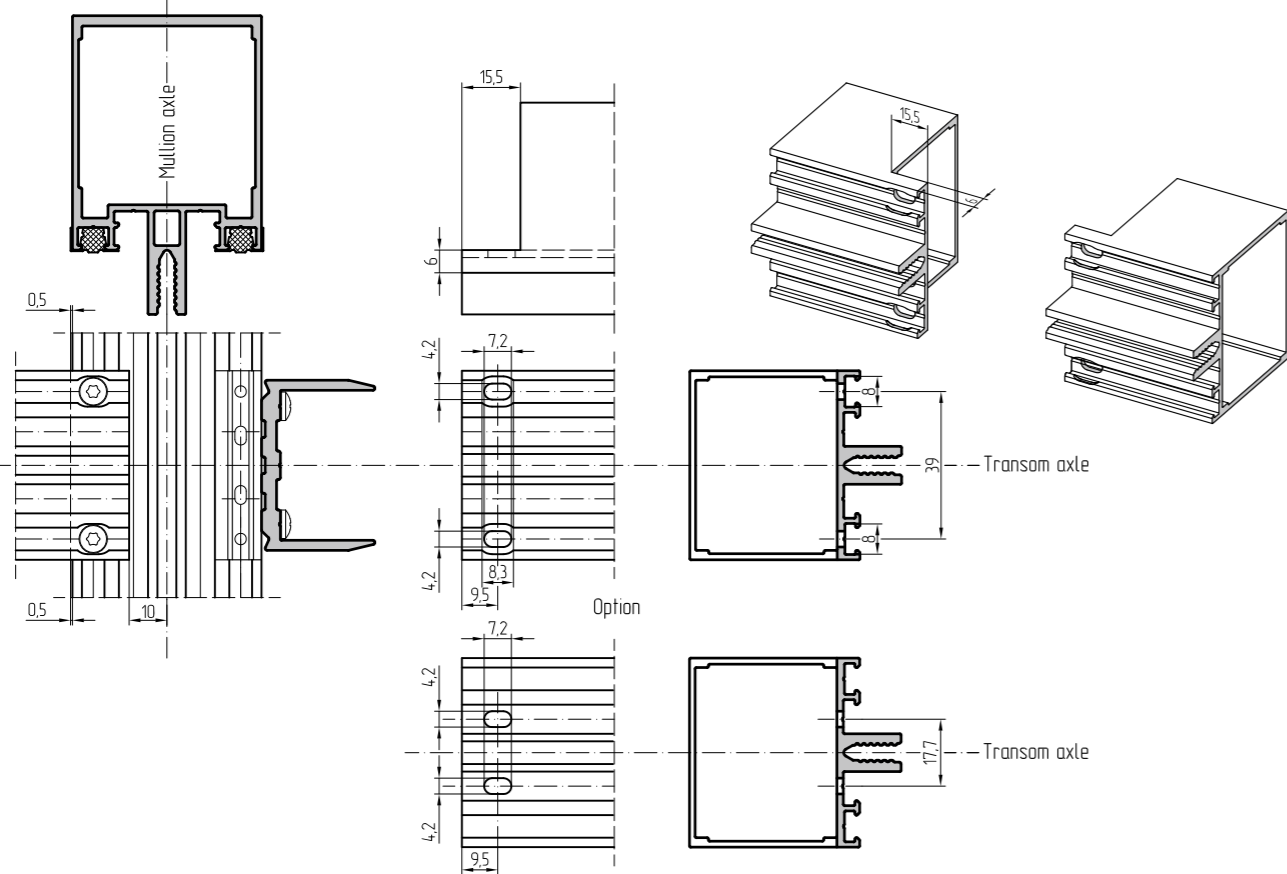

Processing of notch connection transom 6 mm with plastic end plugs AYPC.F50.0921, AYPC.F50.0921-01 and AYPC.F50.0921-02

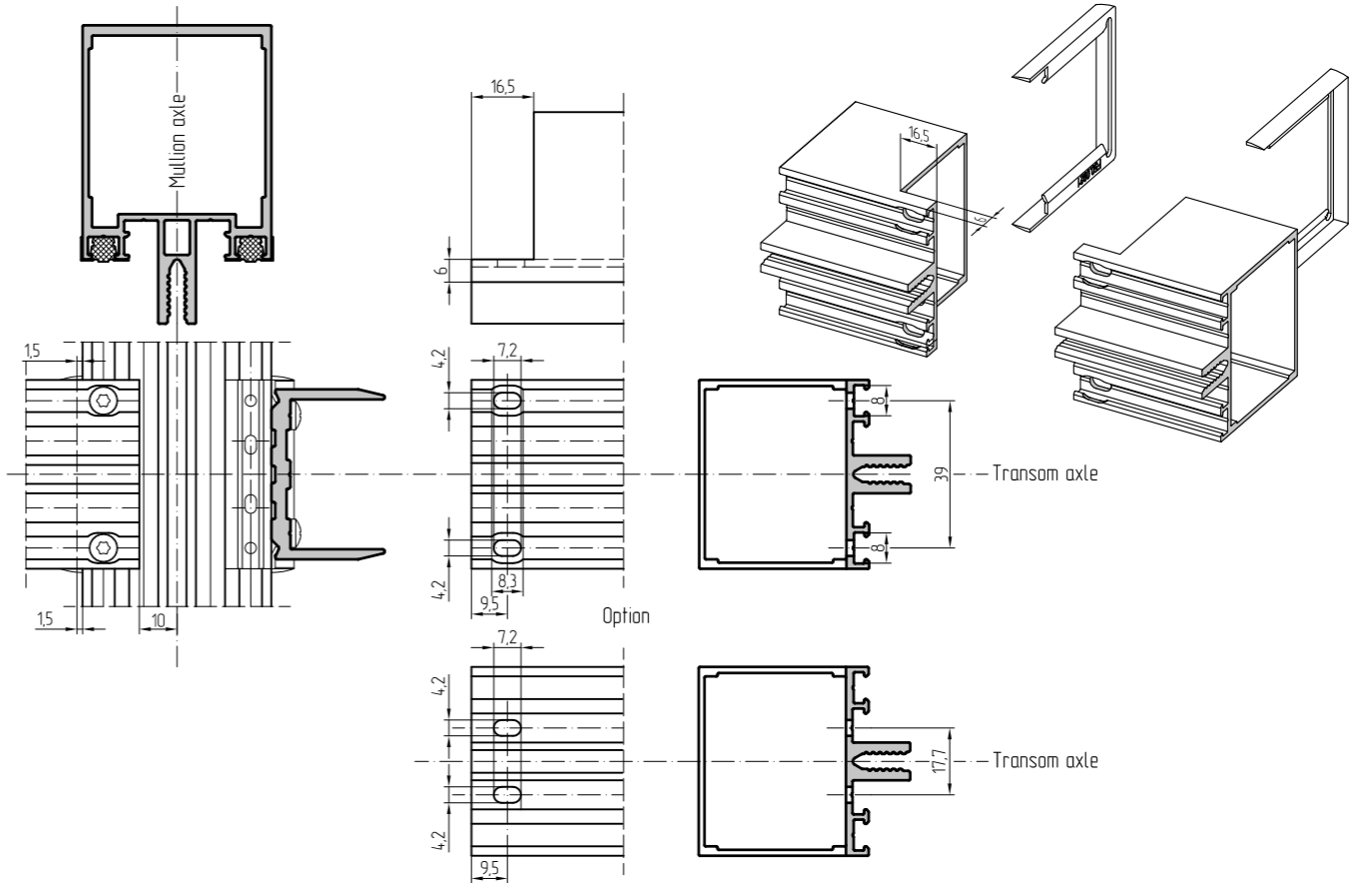

Processing of notch connection transom 6 mm without plastic end plugs

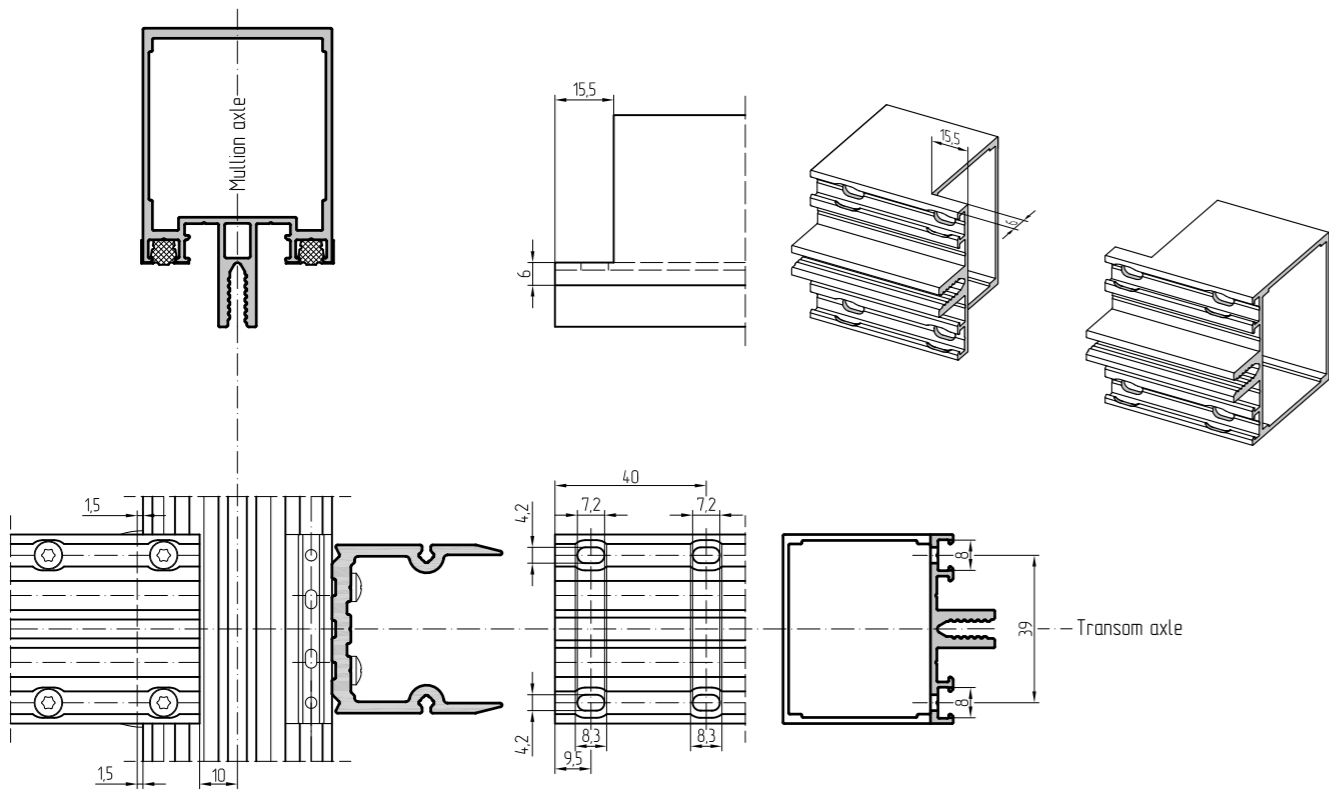

Processing of notch connection transom 6 mm with plastic end plugs AYPC.F50.0921, AYPC.F50.0921-01 and AYPC.F50.0921-02

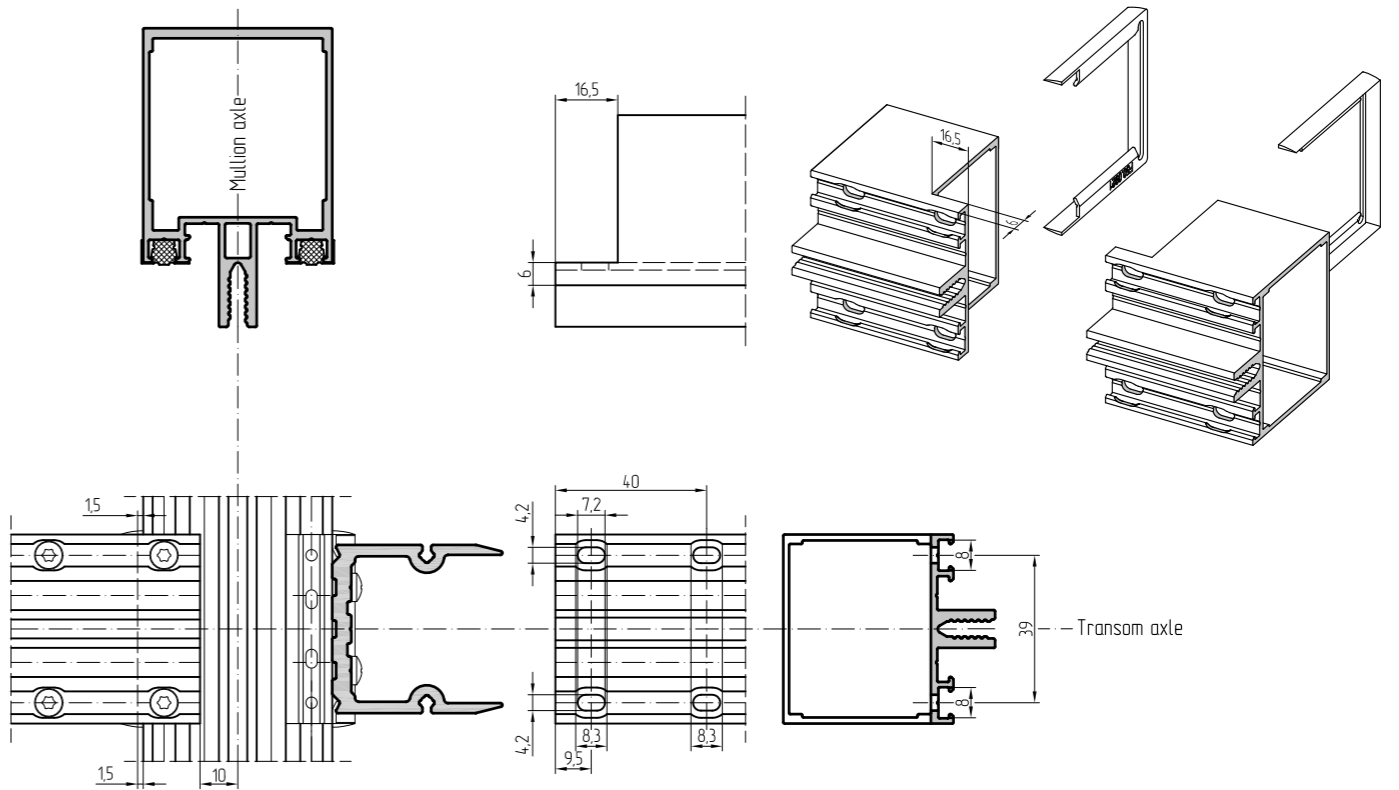

Processing of notch connection transom 6 mm without plastic end plugs

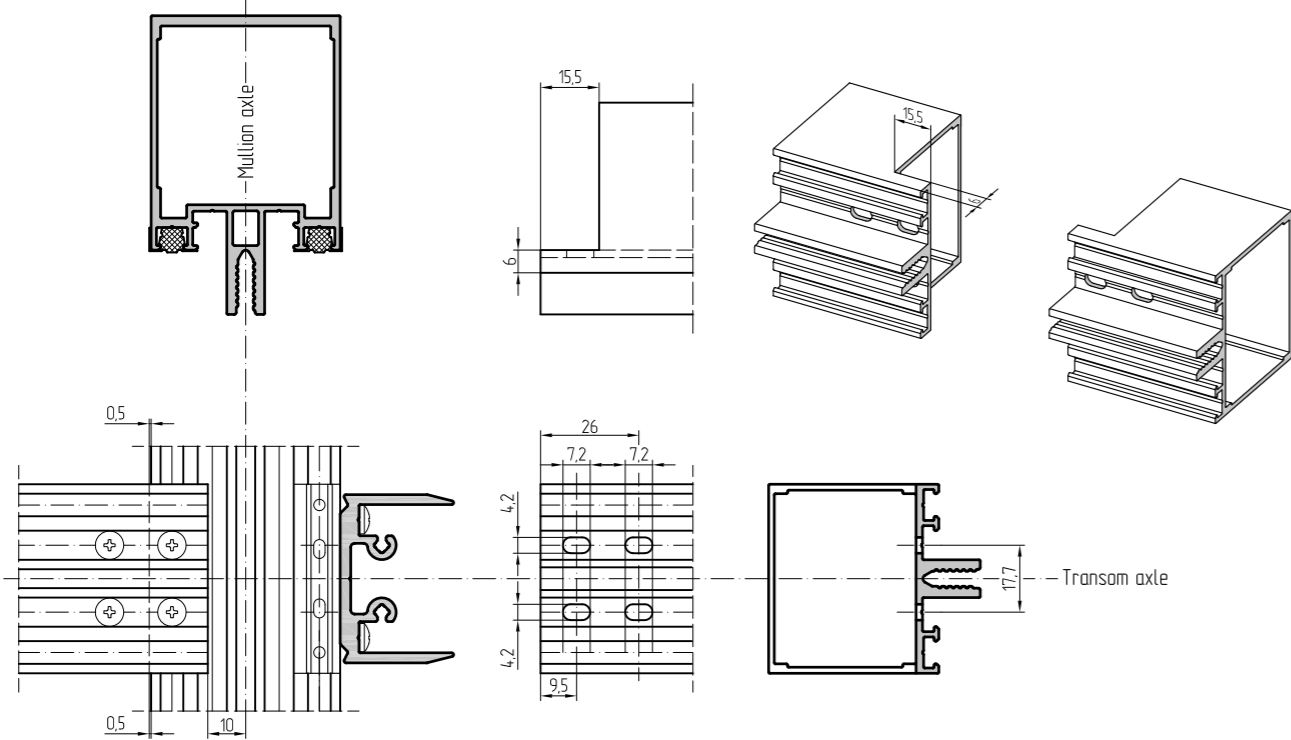

Processing of notch connection transom 6 mm with plastic end plugs AYPC.F50.0921, AYPC.F50.0921-01 and AYPC.F50.0921-01

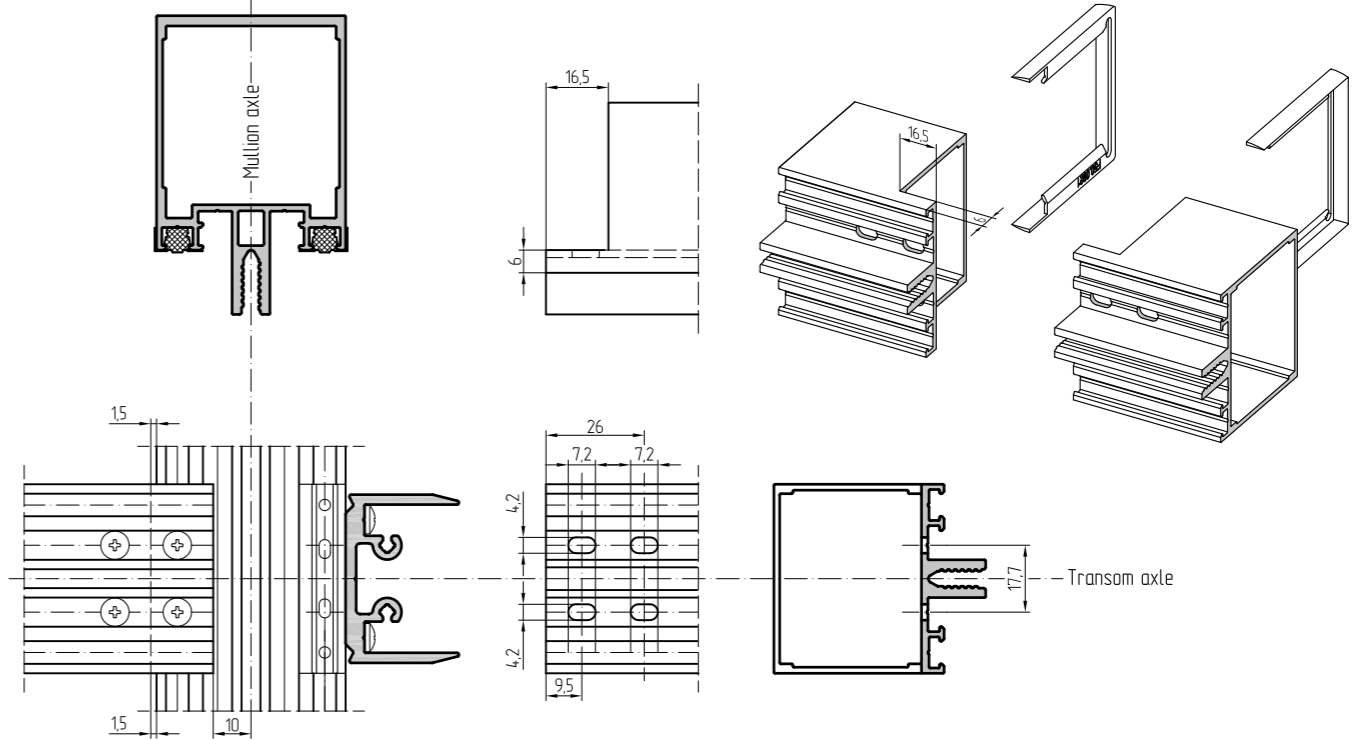

Processing of notch connection transom 6 mm with plastic end plugs AYPC.F50.0921, AYPC.F50.0921-01

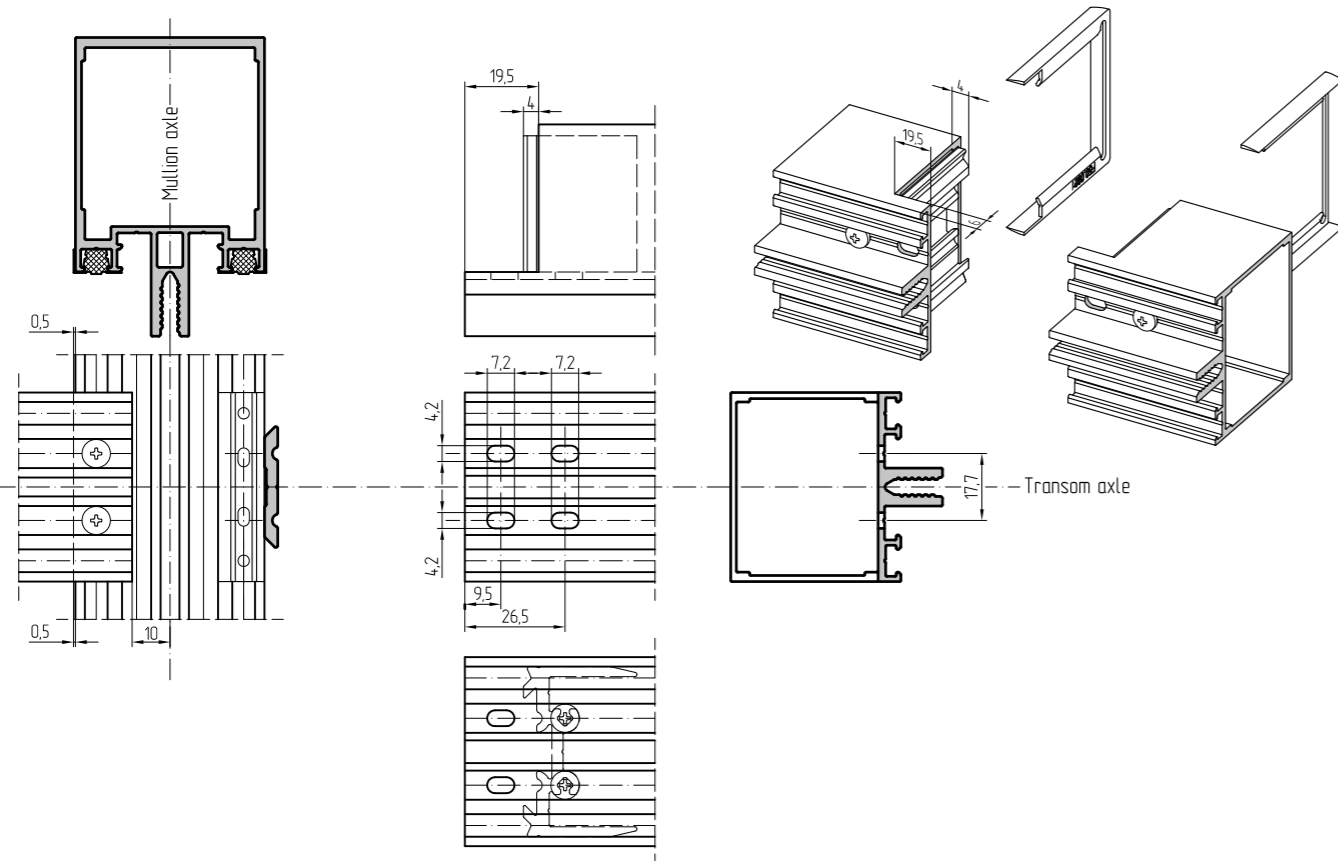

Processing of notch connection transom 6 mm without plastic end plugs

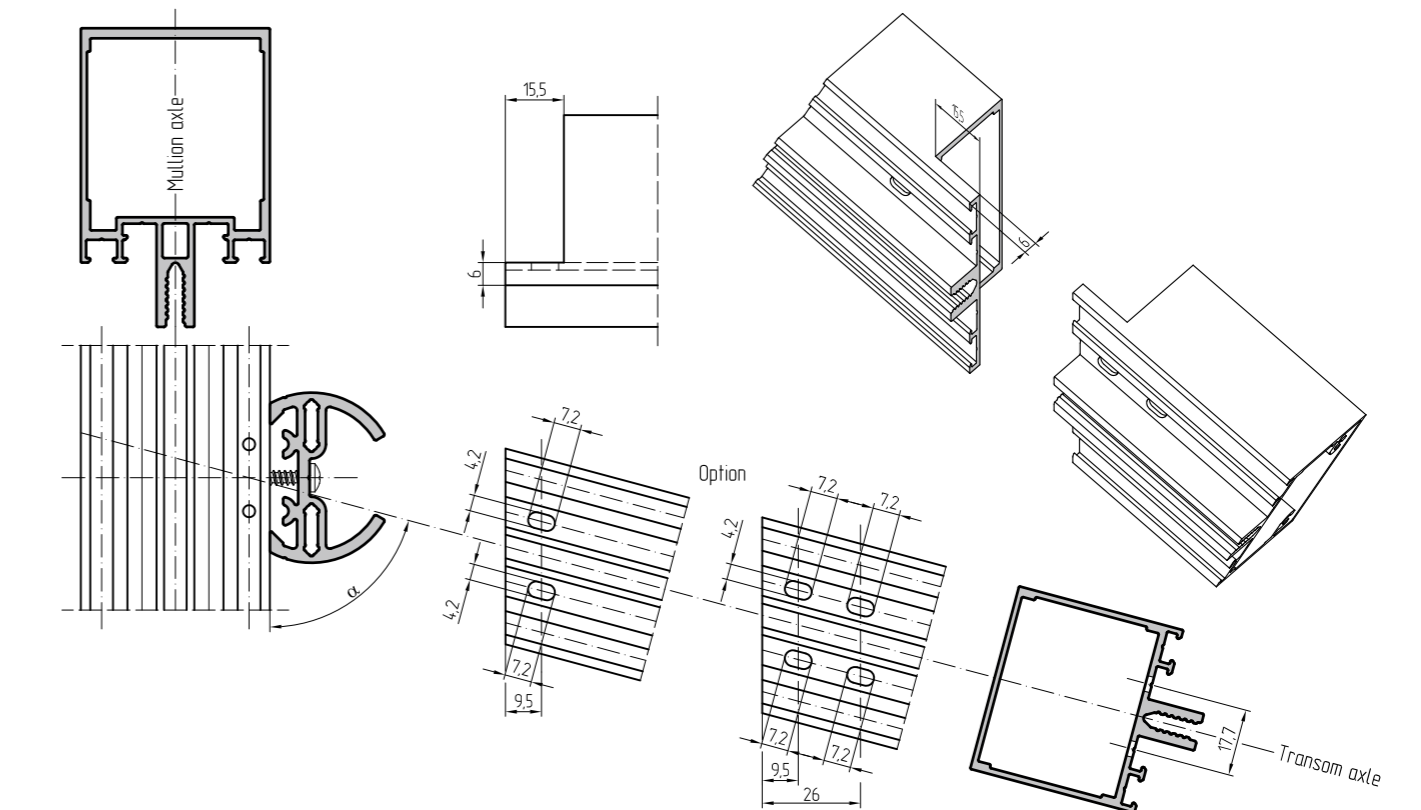

Processing of 6 mm shaped notch connection transoms without plastic end plugs

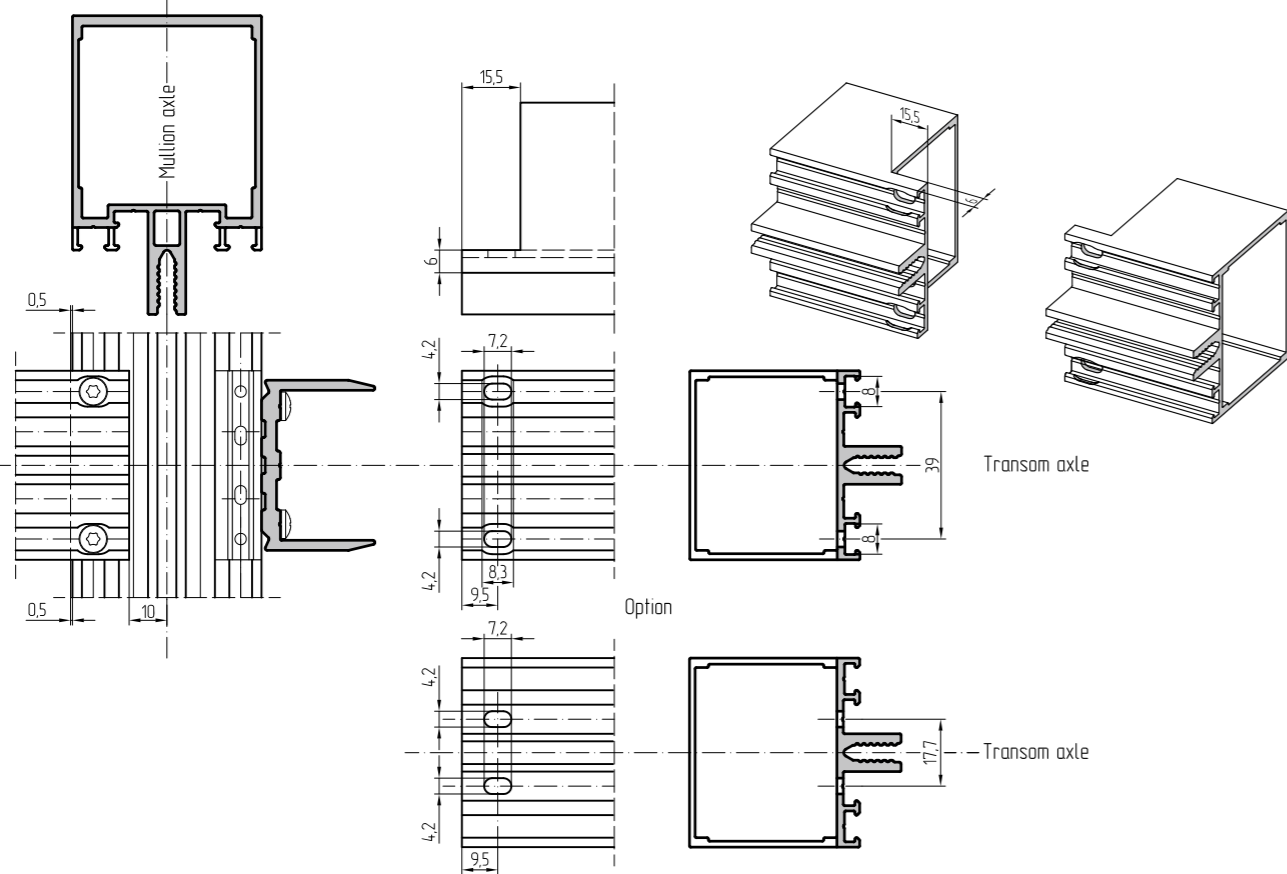

Processing of 6 mm shaped notch connection transoms with plastic end plugs AYPC.F50.0921 and AYPC.F50.0921-01

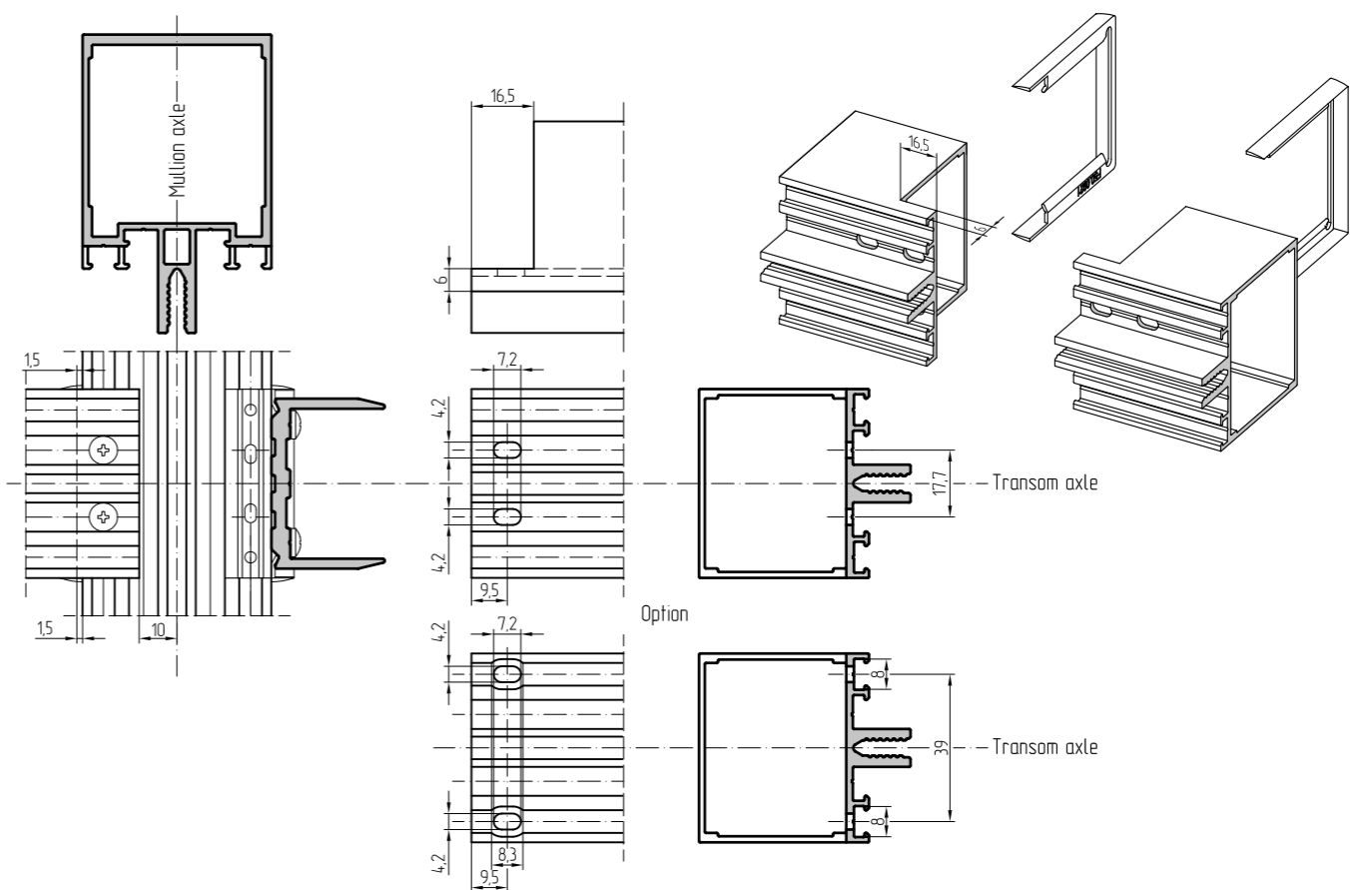

Processing of 6 mm shaped notch connection transoms without plastic end plugs

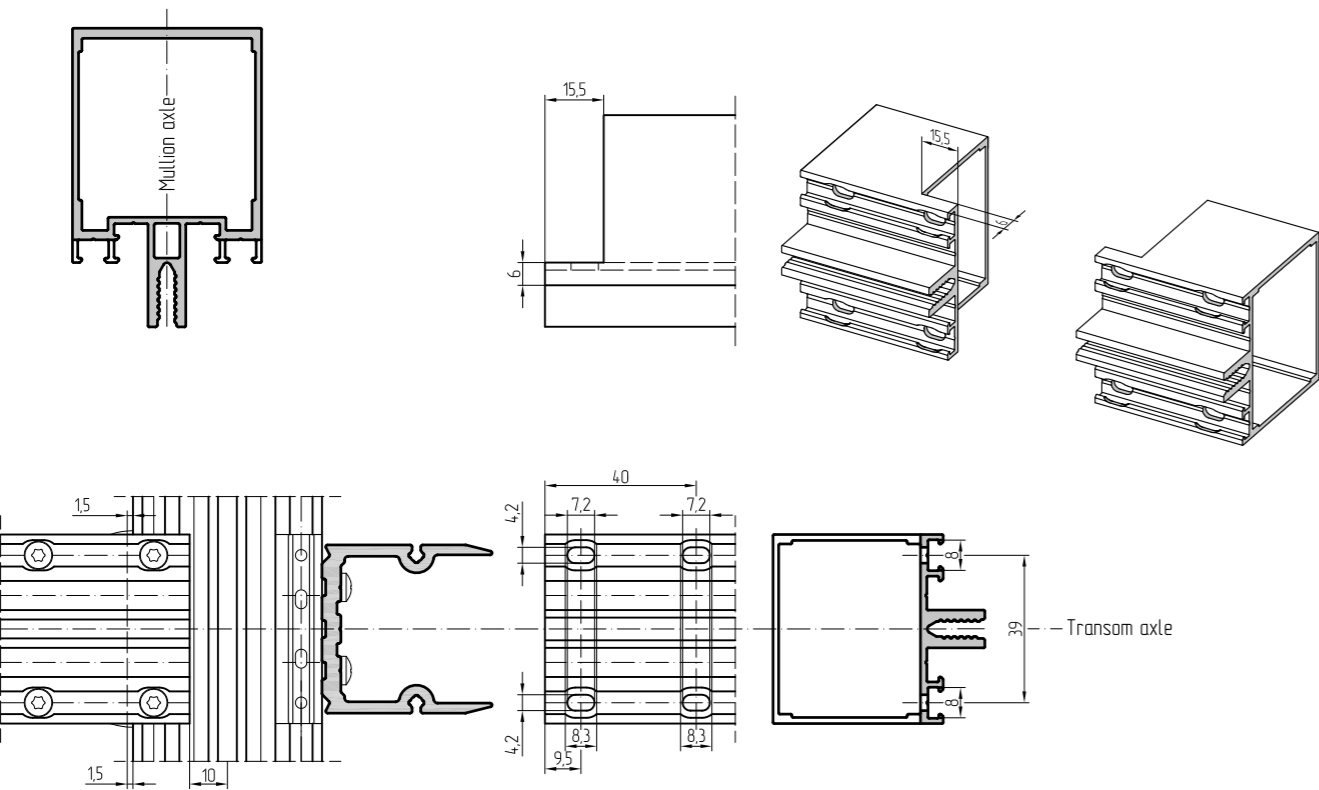

Processing of 6 mm shaped notch connection transoms with plastic end plugs AYPC.F50.0921 and AYPC.F50.0921-01

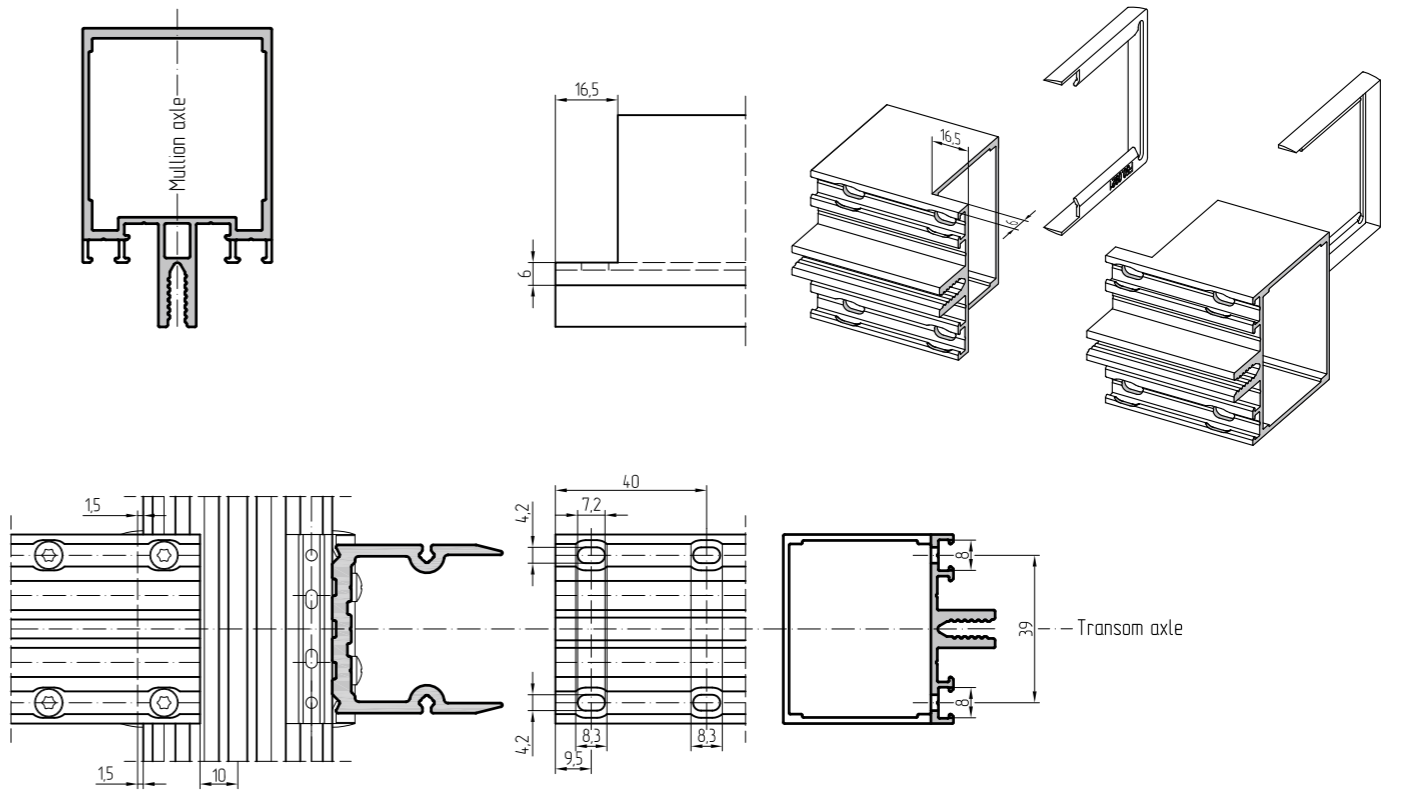

Processing of 6 mm shaped notch connection transoms without plastic end plugs

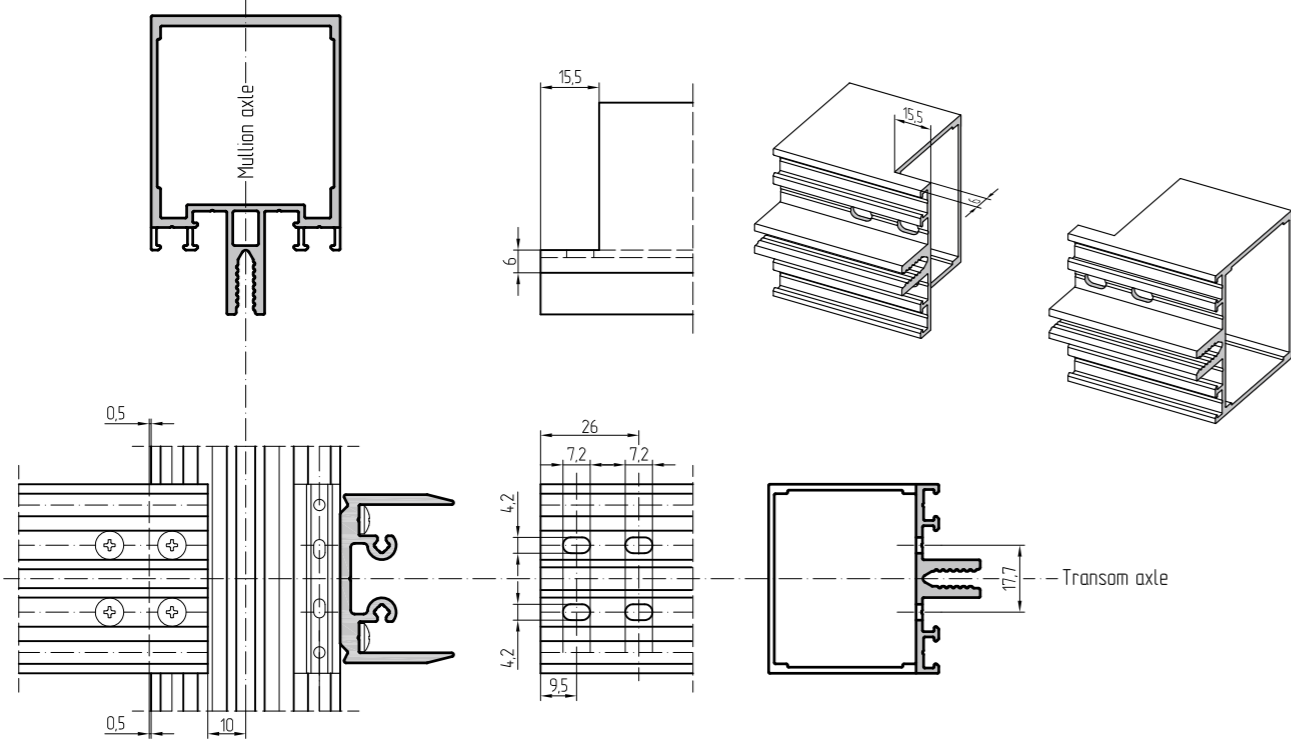

Processing of 6 mm shaped notch connection transoms with plastic end plugs AYPC.F50.0921 and AYPC.F50.0921-01

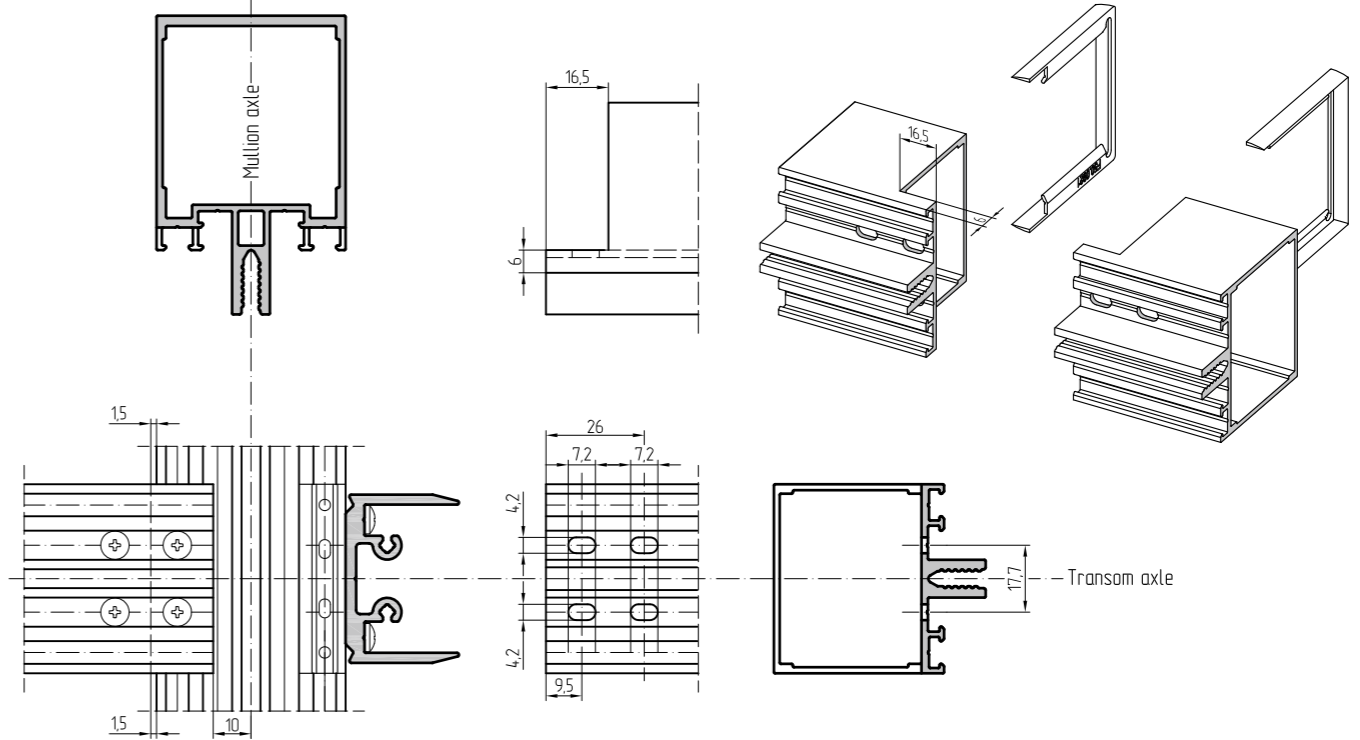

Processing of 6 mm shaped notch connection transoms with plastic end plugs AYPC.F50.0921 and AYPC.F50.0921-01

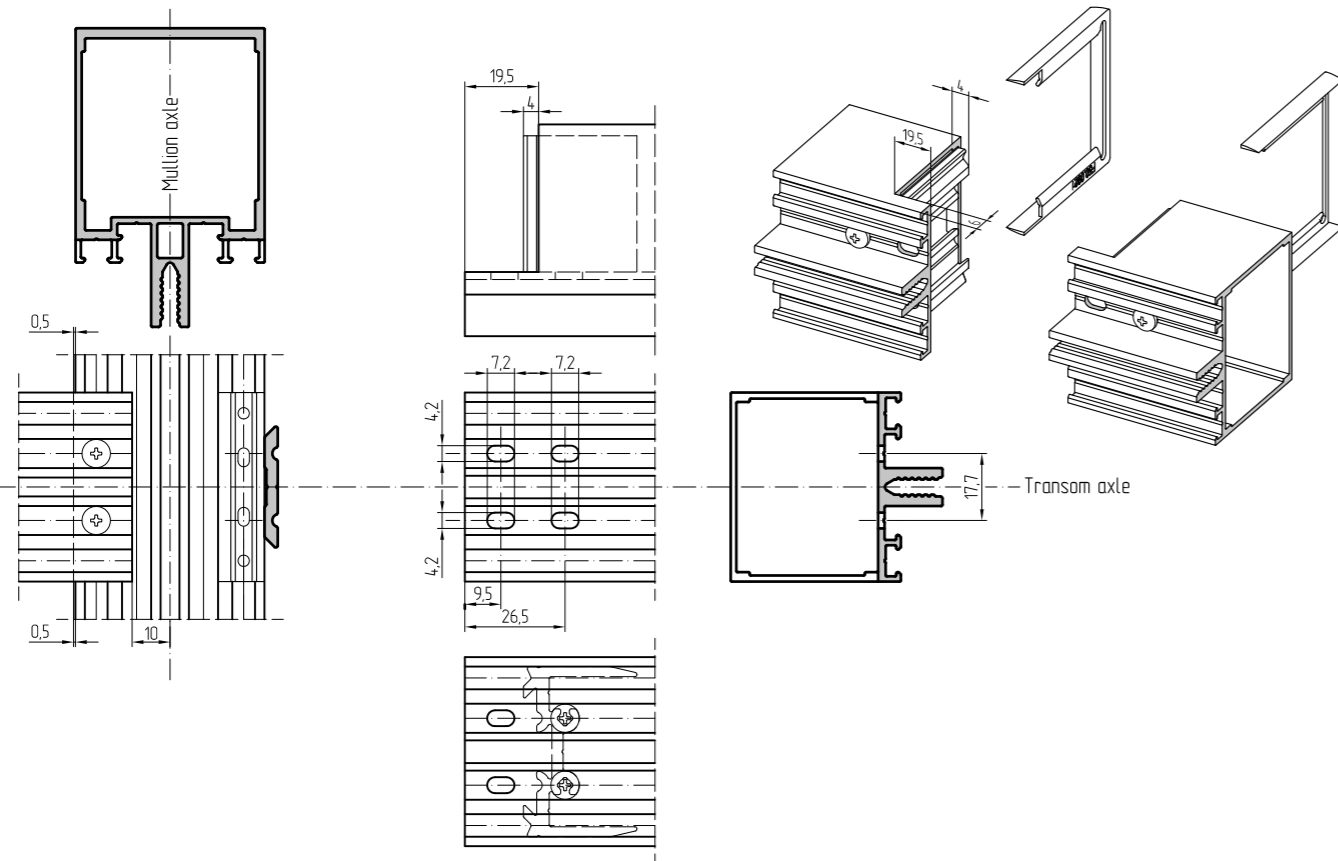

Processing of 6 mm shaped notch connection transoms without plastic end plugs

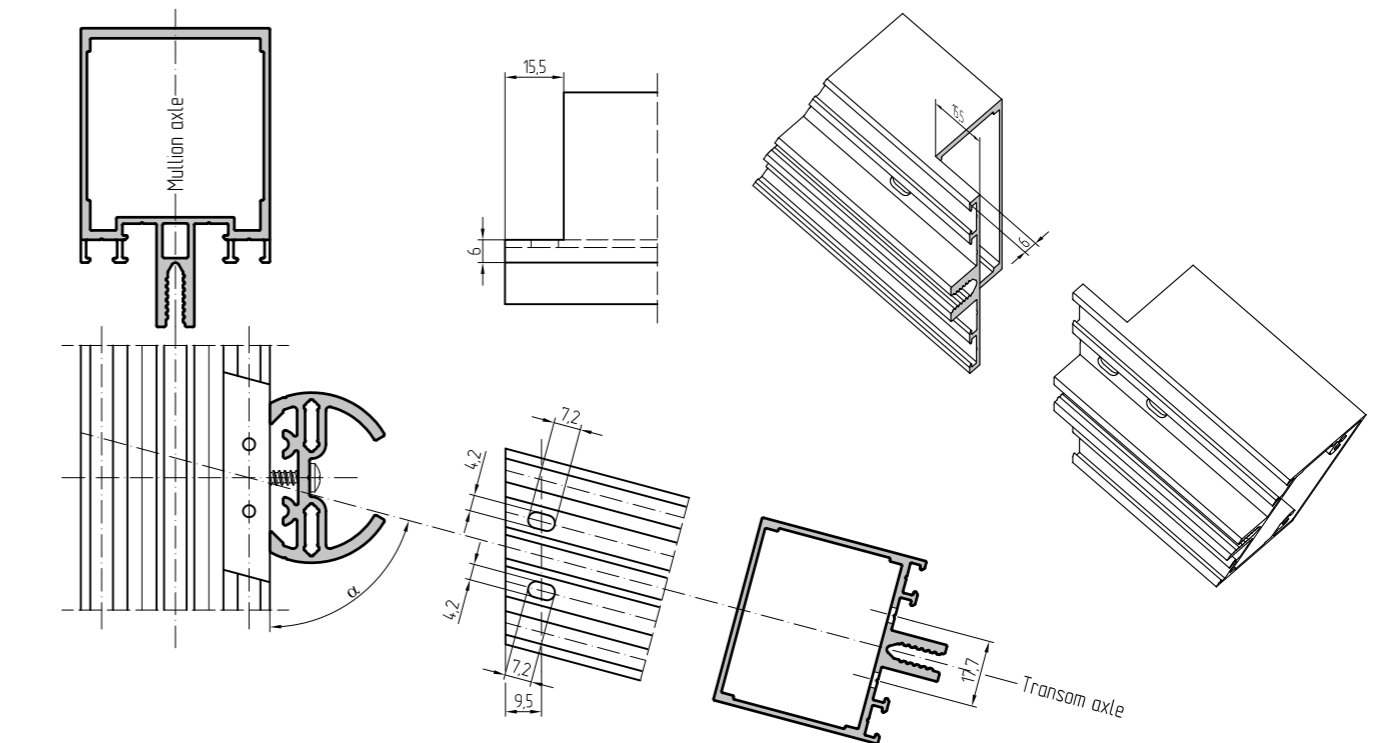





Processing of joining elements made of AYPC.F50.0407, and transoms. Shaped notch connection 6 mm without plastic end plugs.

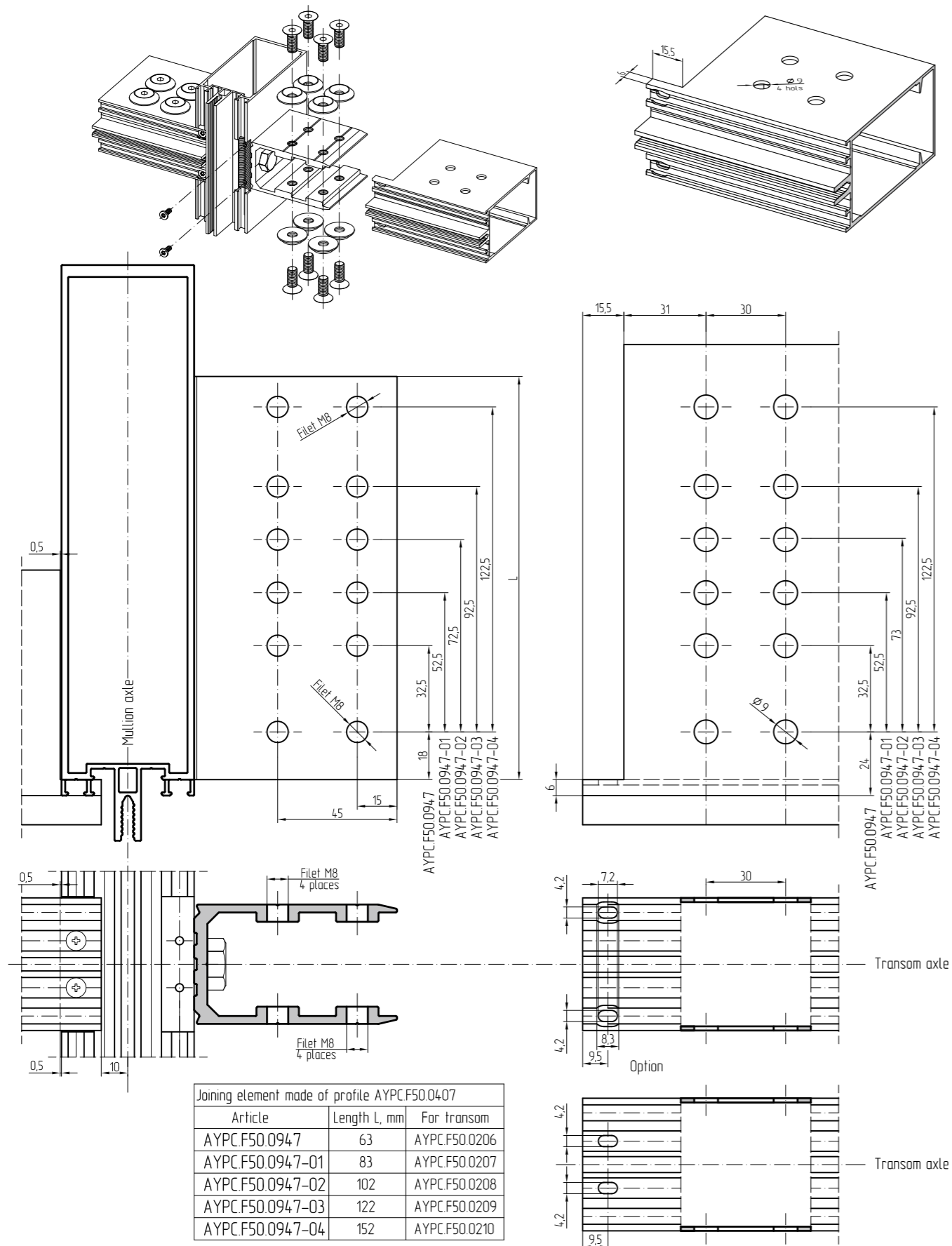

Processing of joining elements made of AYPC.F50.0407, and transoms. Shaped notch connection 6 mm with plastic end plugs.

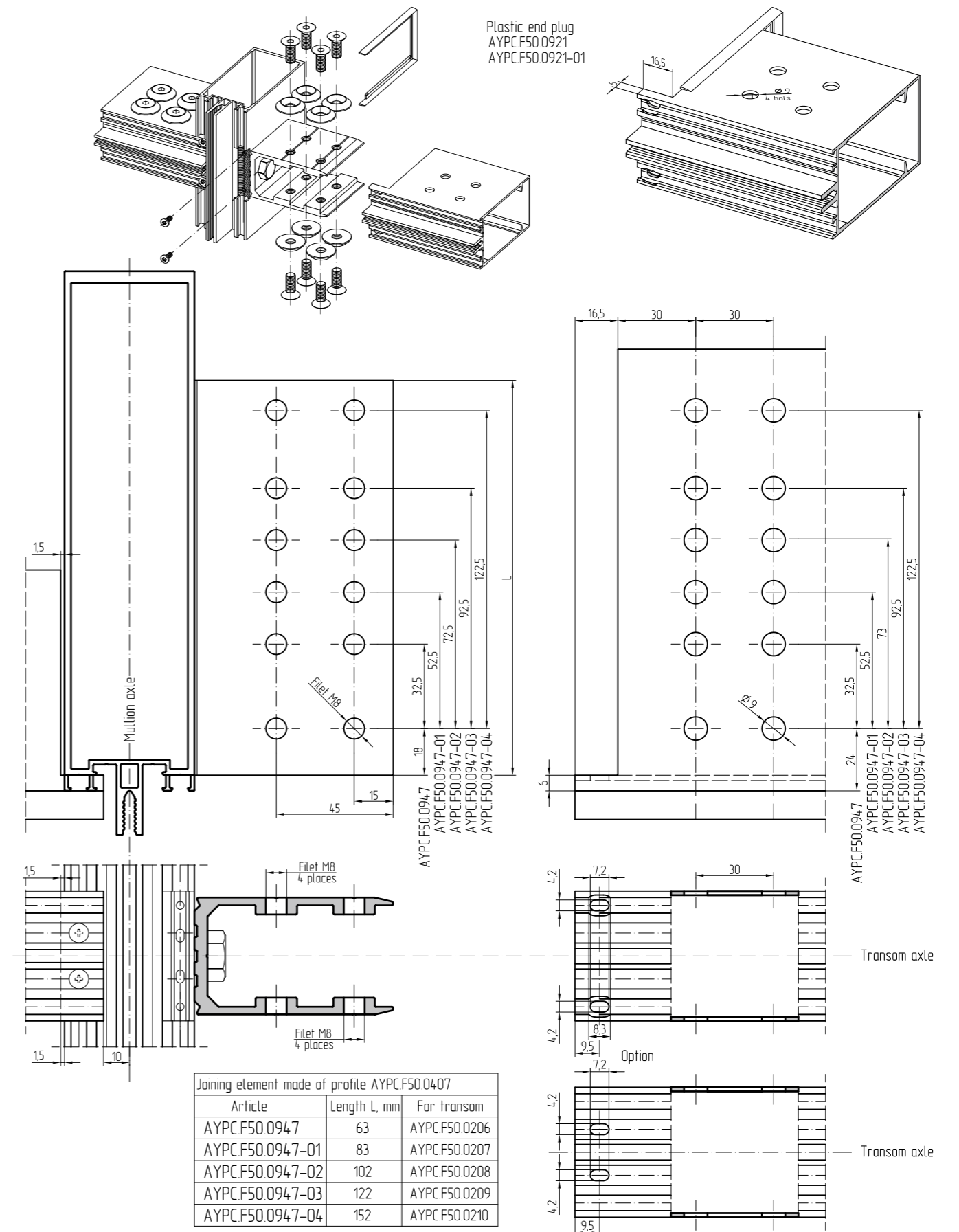

Processing of mullion-transom gaskets (FRK14-FRK19) and distance profiles at the opaque part of facade.

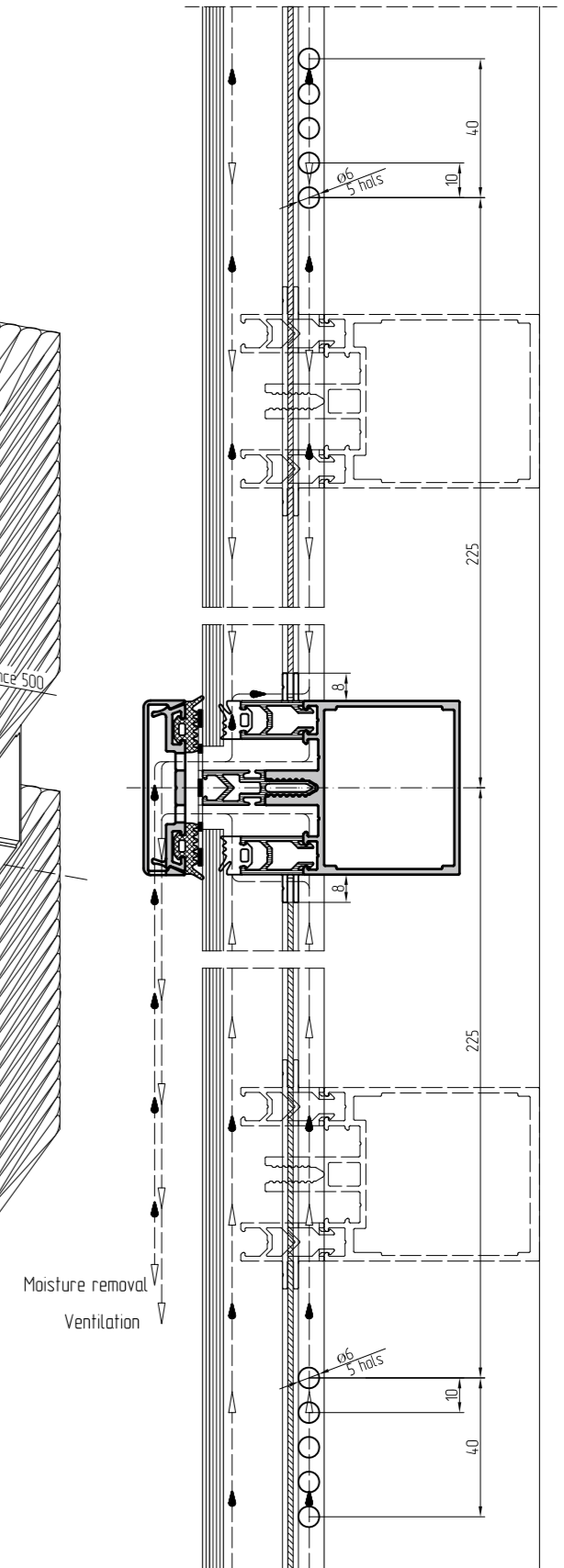
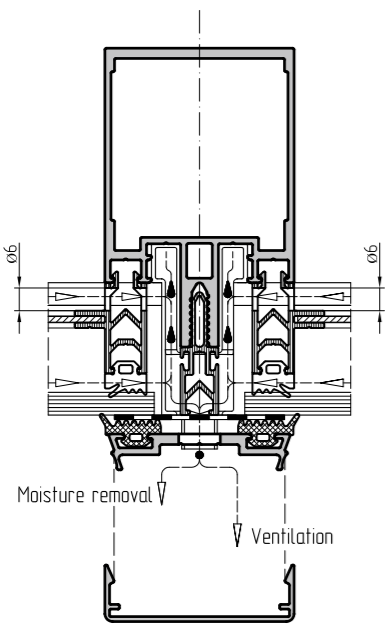
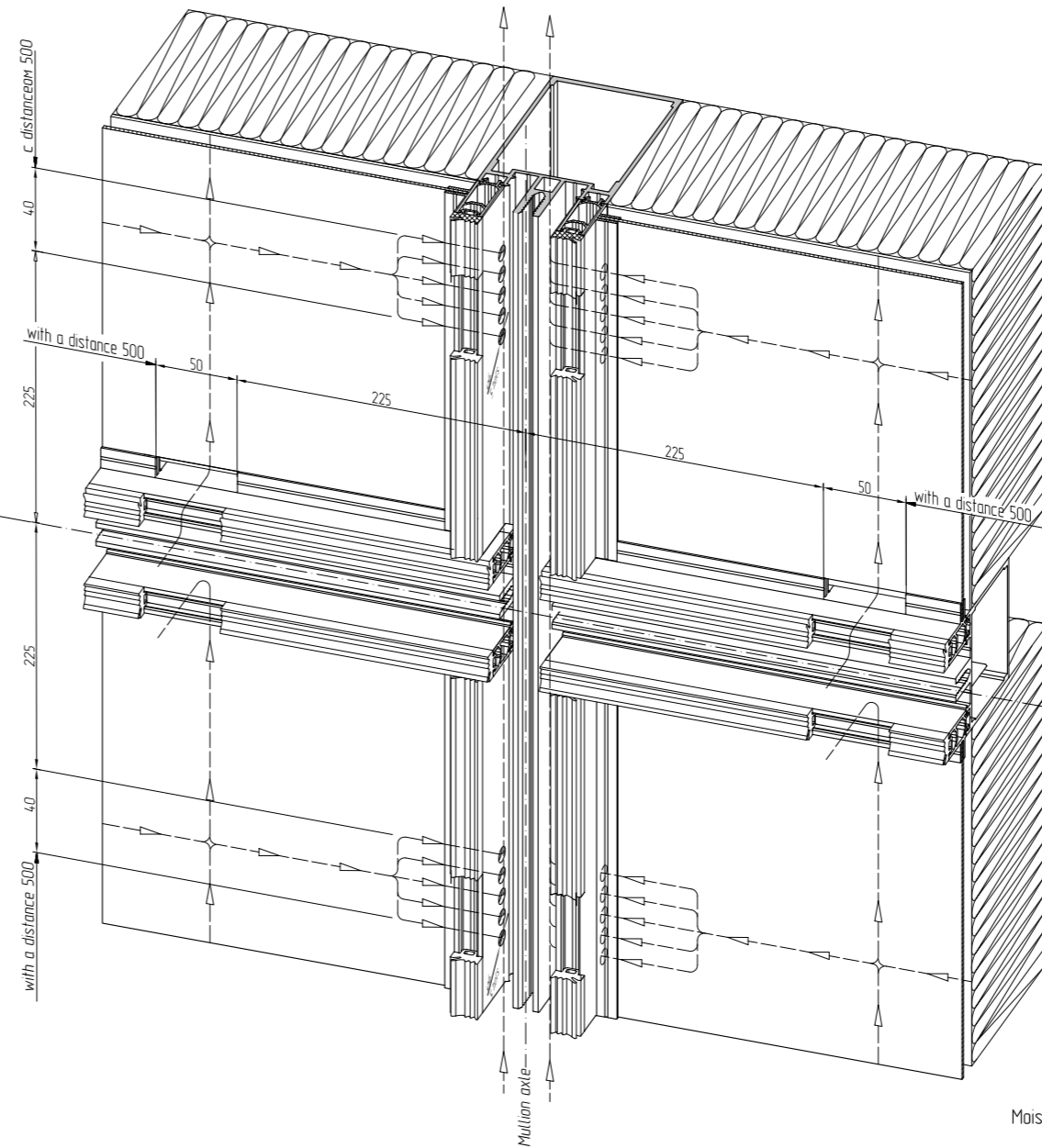
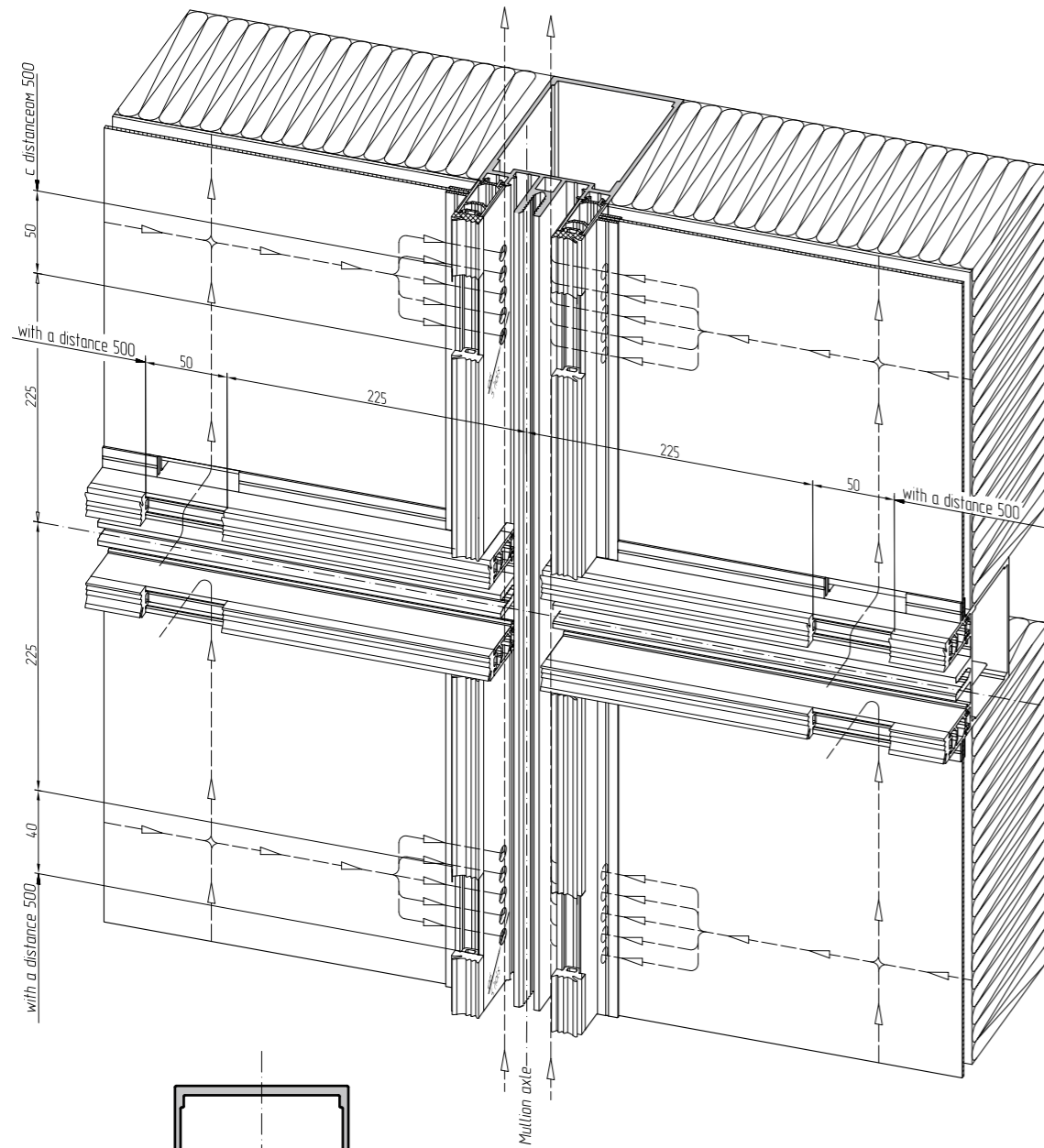



Processing of cover caps AYPC.F50.0504, clamp bar profile AYPC.F50.0601 and aluminium butyl tape

Processing of cover caps AYPC.F50.0504, clamp bar profile AYPC.F50.0601 and FRK25 gasket of clamp bar profile

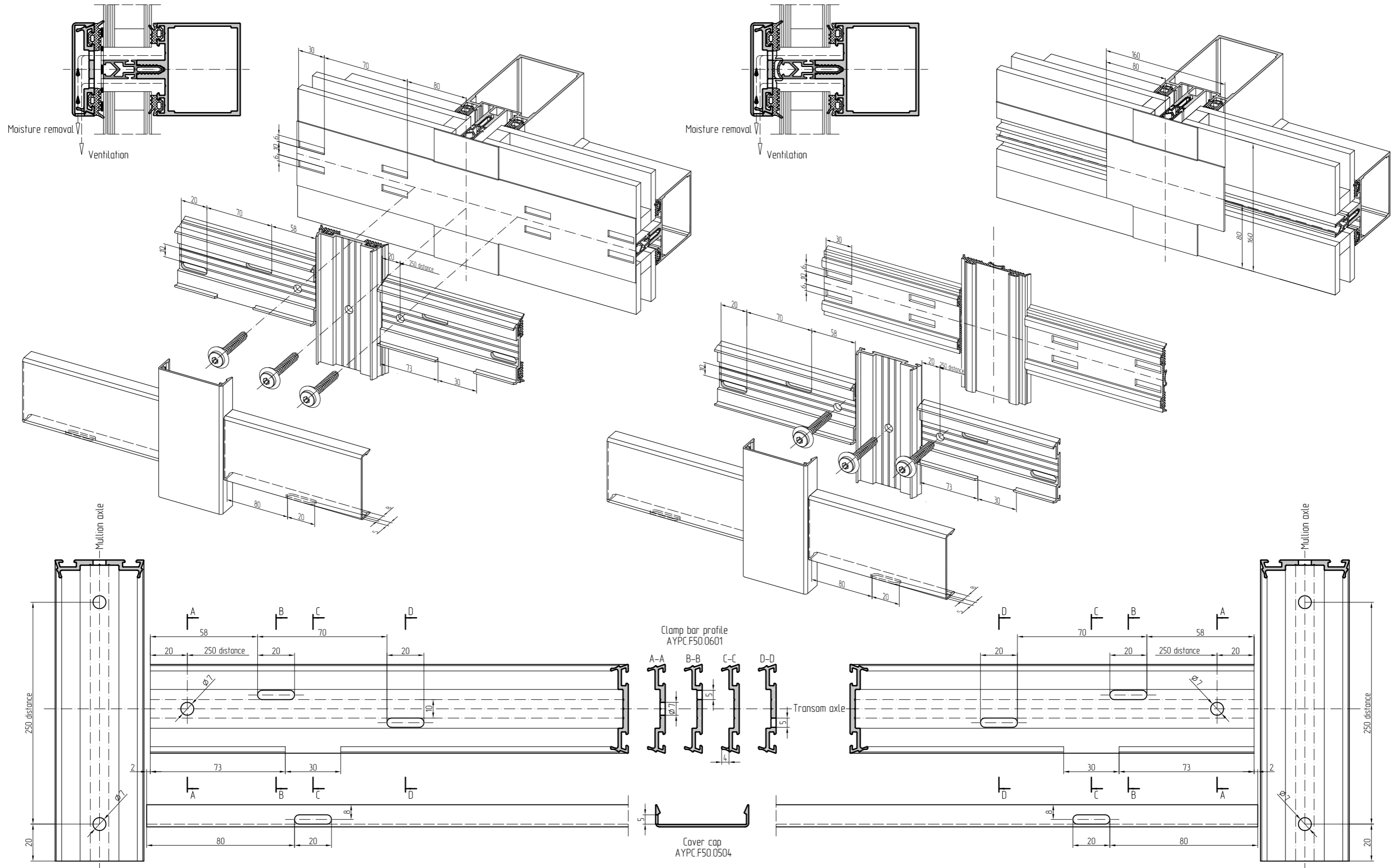

Processing of cover caps AYPC.F50.0507, clamp bar profile AYPC.F50.0621 and aluminium butyl tape

Processing of cover caps AYPC.F50.0507, clamp bar profile AYPC.F50.0621 and FRK25 gasket of clamp bar profile

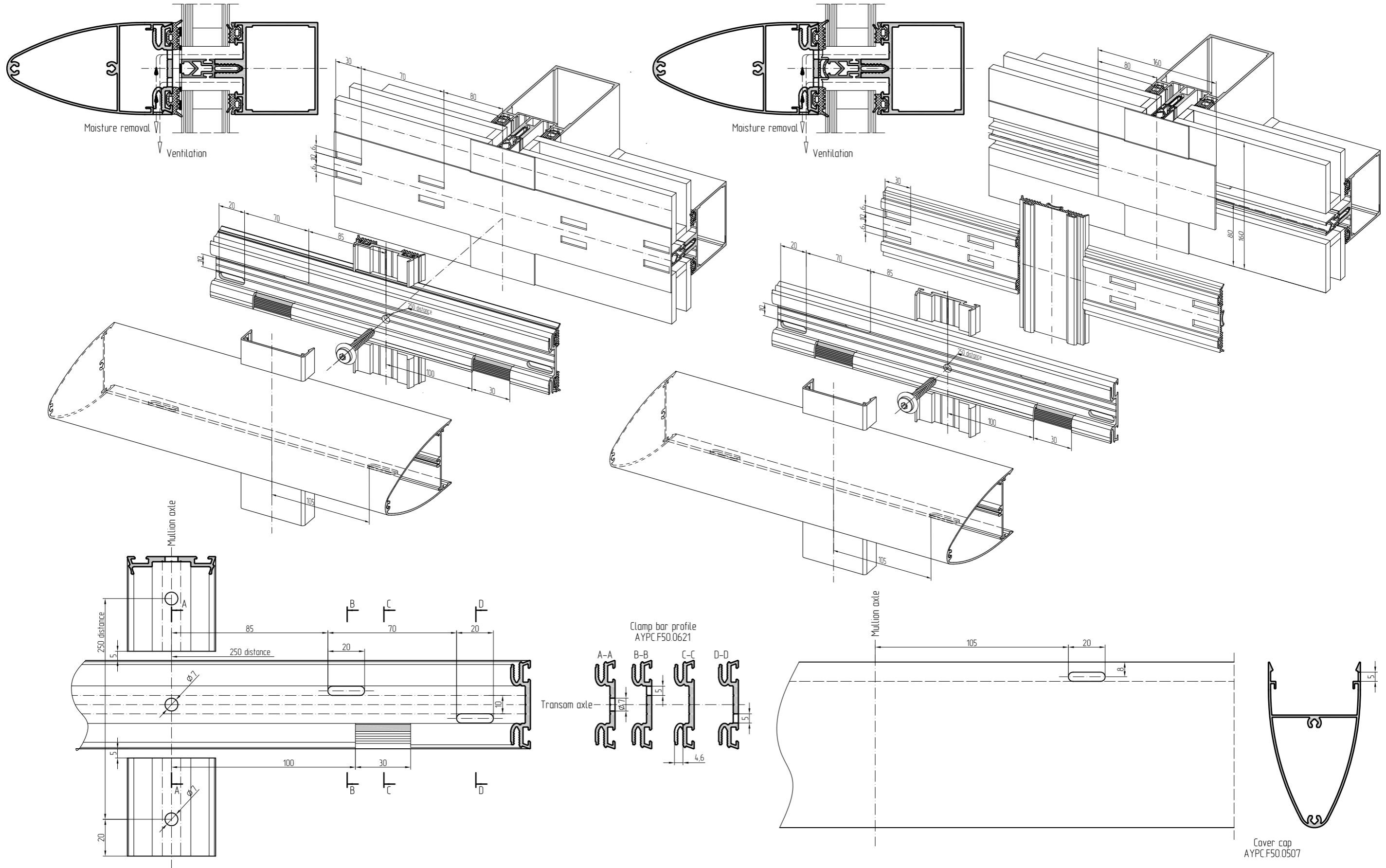

Processing of clamp bar profile AYPC.F50.0601 and clamp bar profile AYPC.F50.0620

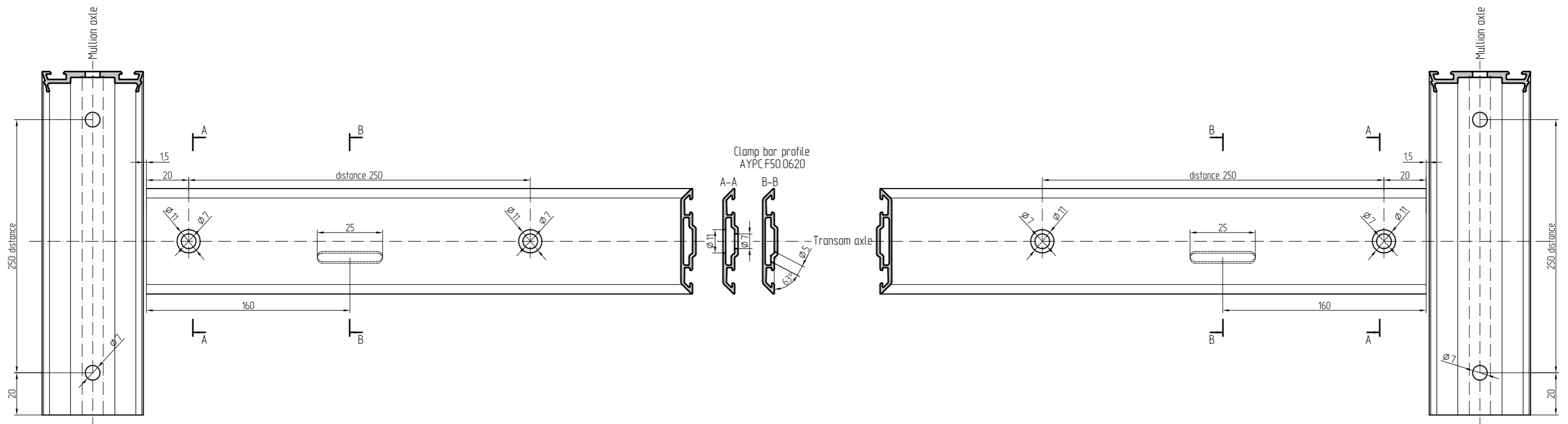
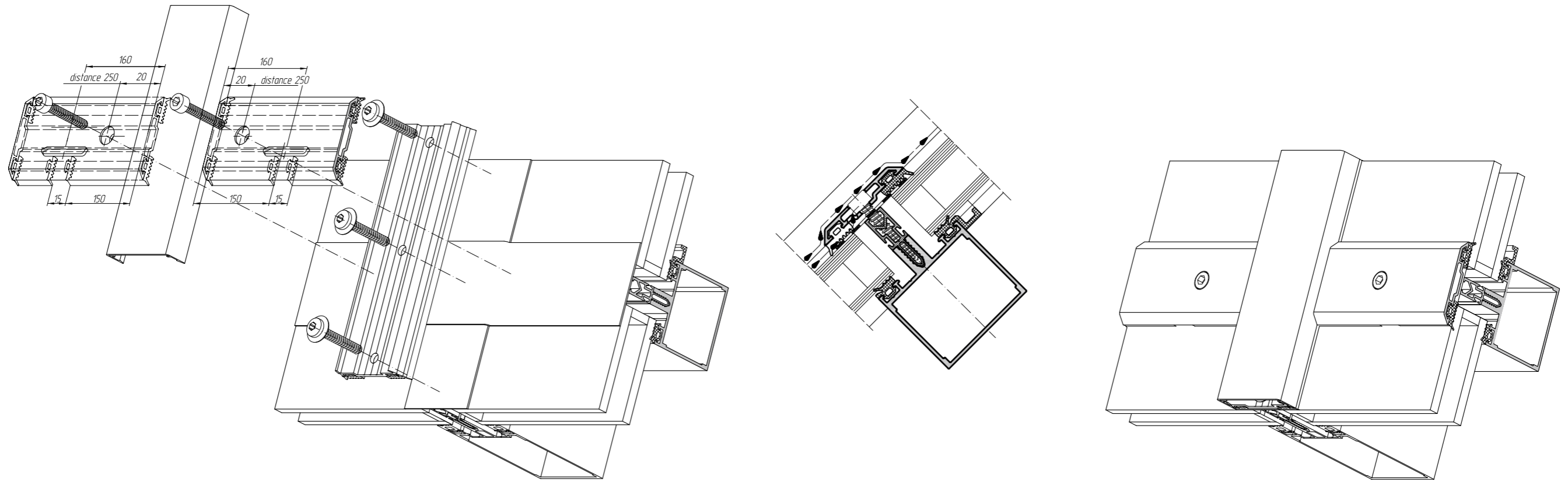

Processing of seam gasket for glass unit AYPC.F50.0911, AYPC.F50.0912, AYPC.F50.0913, AYPC.F50.0914 and mounting of glass unit supports

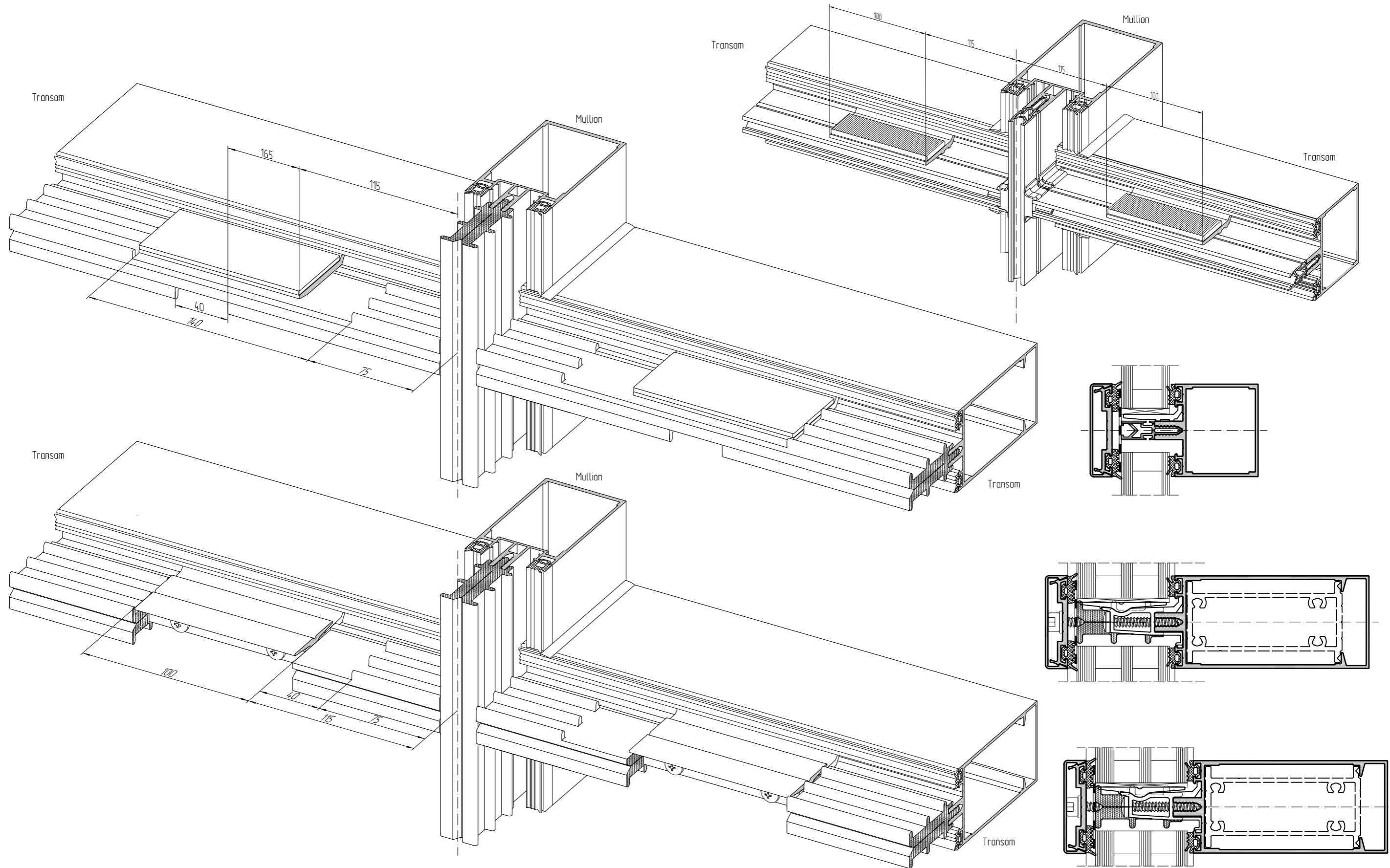





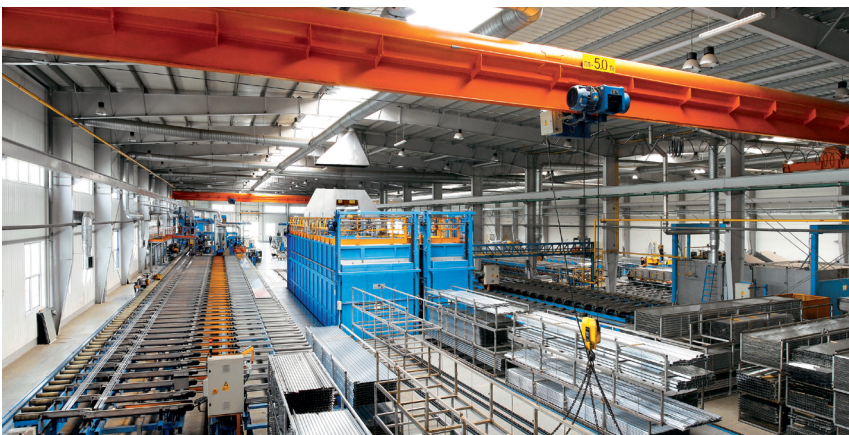

While developing and producing ALT F50 curtain wall system, we have considered the best practices of the leading European companies.

ALUTECH system hardware and accessories correspond to world quality standards.

Our own manufacturing facilities allow us to be flexible with our clients. We take into account all their specific requirements for each detail and element. We are also able to produce non-standard orders in the shortest time span.

**AluminTechno JLLC**  
 tel.: +375 17 345 81 43, 45,  
 fax: +375 17 345 81 48  
 e-mail: market@alt.by

Certificate № 800017207  
 issued by the Ministry  
 of Foreign Affairs of the Republic of  
 Belarus 03.12.2002 № 800017207

